

# Operating Instructions

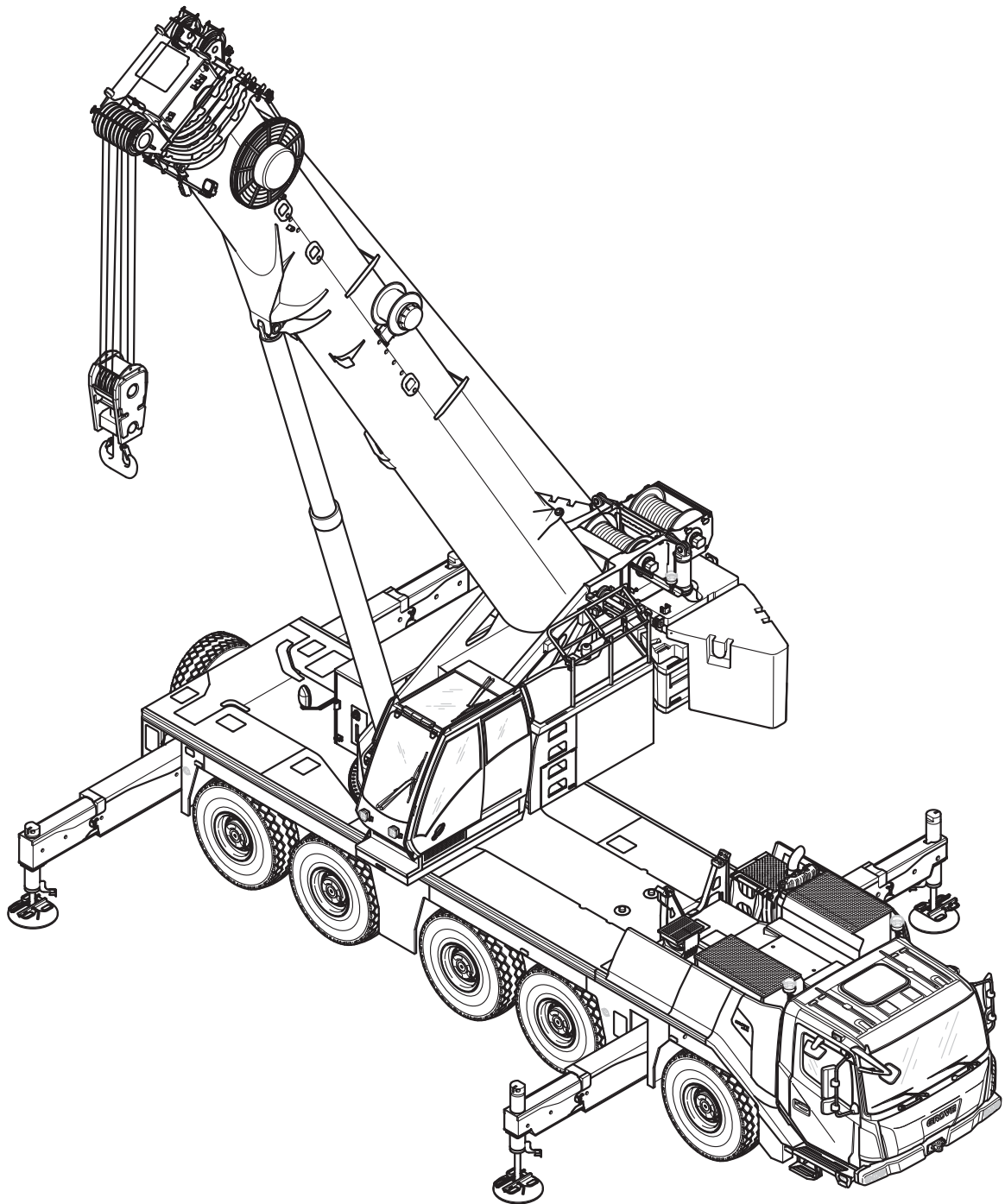

**3 302 627en**  
03.07.2017

CLICK HERE TO **DOWNLOAD** THE COMPLETE MANUAL

- Thank you very much for reading the preview of the manual.
- You can download the complete manual from: [www.heydownloads.com](http://www.heydownloads.com) by clicking the link below



- Please note: If there is no response to CLICKING the link, please download this PDF first and then click on it.

CLICK HERE TO **DOWNLOAD** THE COMPLETE MANUAL

## Attaching the outrigger pads

After mounting the outrigger beam, you must attach the outrigger pad.

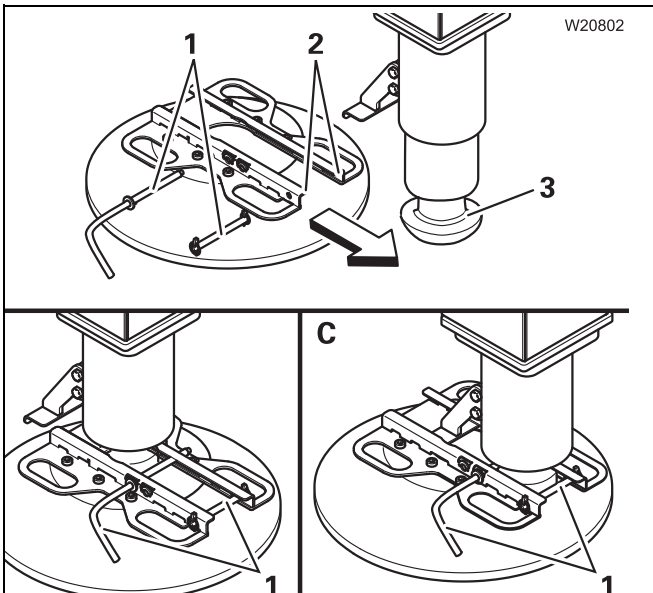

- (A) – Remove the pin (1).
- Extend the outrigger cylinder far enough so that the bearing surface (3) is below the guide (2).
- Push the outrigger pad onto the outrigger cylinder.
- Move the outrigger pad into required position.
  - On site, move it to the working position (B).
  - If you need to drive to the site, in driving position (C).
- Insert the pins (1) and secure them.

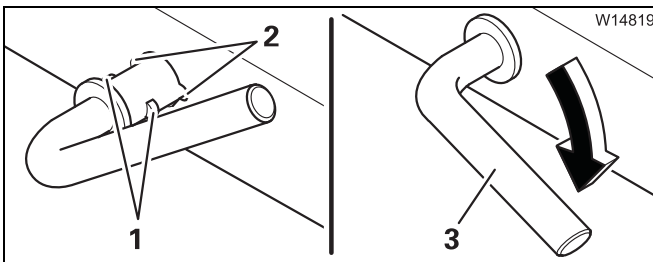

### Securing pins

- Plug the pin with the peg (1) through the cutout (2).
- Turn the grip (3) downward.
- Position the other outrigger pads in the same way.

## 1.13

### Note on error messages with removed outrigger beams

Depending on the outrigger beam, the following error messages can occur after removal.

5801.x.xx.x	5802.x.xx.x	5803.x.xx.x	5804.x.xx.x
5806.x.xx.x	5807.x.xx.x	5808.x.xx.x	5809.x.xx.x

The error messages indicate only that the electrical connection between the outrigger beams and the crane control is disconnected. They have no further effect on driving.

The error messages are displayed in the driver's cab on the CCS display until the outrigger beams are reinstalled.

## 1.14

### Technical data

Designation	Diameter x Height in m (ft)	Weight in kg (lbs)
Plastic outrigger pad diameter	0,50 x 0,16 (1,64 x 0,52)	25 (55)
Steel outrigger pad diameter	0,50 x 0,16 (1,64 x 0,52)	50 (110)
Front outrigger <sup>1)</sup> , complete per packet	2800 x 0,30 x 1,10 (9,20 x 1,00 x 3,65)	950 (2 100)
Rear outrigger <sup>1)</sup> , complete per package	2800 x 0,35 x 1,10 (8,20 x 1,15 x 3,45)	1050 (2 315)

1) Consists of two sets

## CCS display

### Menu changes

Depending on the program version, menus are displayed differently, deviating from the specifications in the *operating manual*, and there are additional displays.

#### Start menus

The specifications in this section apply for crane types GMK3060 / GMK4100L-1 / GMK5150 / GMK5150L / GMK5180-1 / GMK5200-1/ GMK5250L.

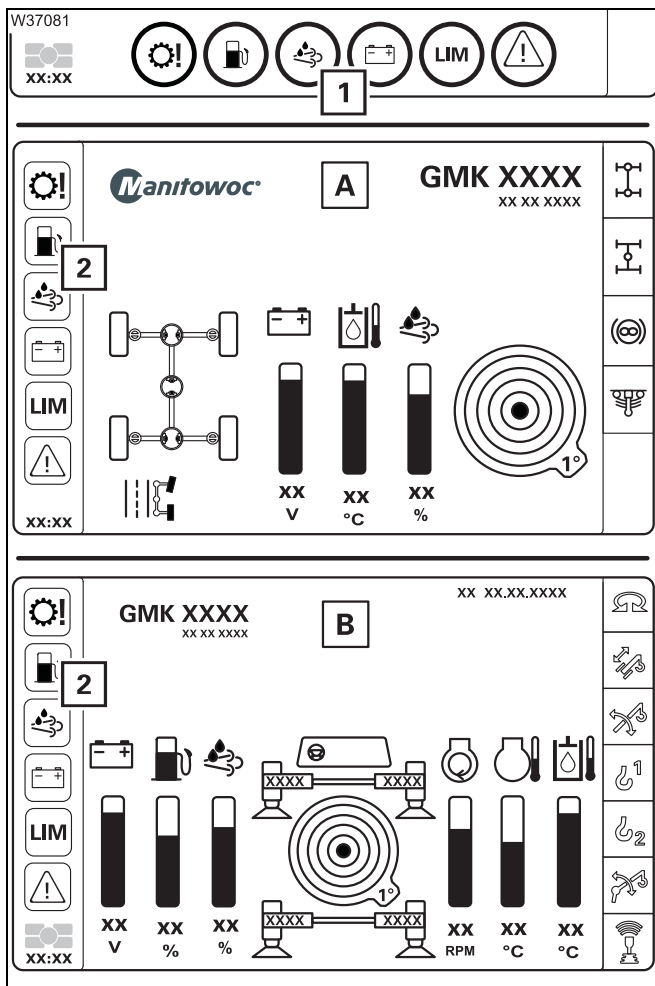

Depending on the program version, new start menus are displayed.

(A) – Start menu in the driver's cab

(B) – Start menu in the crane cab

The operating manual supplied describes the start menus with a display area (1).

These symbols are displayed in the new start menus in the display areas (2) and therefore, are immediately visible regardless of the menu opened.

All other displays are arranged differently, yet the function corresponds to the specifications in the *operating manual* supplied.



## Correction sheet

### Possible reeving methods on the main boom

Contrary to the information specified in the operating manual, there are corrected hoist rope reevings on the main boom for the GMK5150/GMK5150L truck crane.

Only reeve the hoist rope as described/illustrated in this correction sheet.

It is important that you still observe all notes and safety instructions regarding rigging work on the main boom in the operating manual supplied.

**With 6 head sheaves**

- ▣▣▣▣▶ *With 8 head sheaves, S. 4.*
- ▣▣▣▣▶ *With 9 head sheaves, S. 8.*

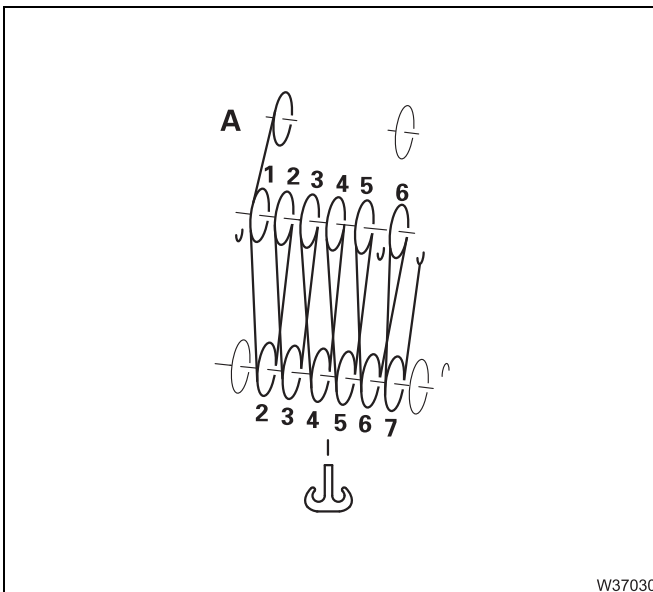

**8 sheave hook block**

	Reeving
<b>A</b>	12x



---

## **The operating instructions consist of the following chapters:**

- 1 Overview**
- 2 Basic safety instructions**
- 3 Operating elements for driving**
- 4 Starting/switching off the engine – for driving**
- 5 Driving mode**
- 6 Driving modes**
- 7 Transport**
- 8 Malfunctions in driving mode**
- 9 Operating elements for crane operation**
- 10 Starting/switching off the engine – for crane operation**
- 11 Crane operation**
- 12 Rigging work**
- 13 Driving with a rigged truck crane**
- 14 Malfunctions during crane operation**
- 15 Index**

## 1.5

### Technical data

#### GROVE crane GMK5150

Permissible temperature range: -25 °C to +40 °C (-13 °F to +104 °F)

Crane designation:	Truck crane as per DIN 15 001, Part 1
Crane application:	Service crane as per DIN 15 001, Part 2
Crane classification:	Hoist class H1 to DIN 15 018, Part 1 Crane class A1 to ISO 4301, Part 2

The crane is designed to crane class A1 (as defined in ISO standard 4301 - 2). This relates to the engineering design (specification of quality) and is not a guarantee in the sense of § 443 BGB (German Federal Law).

### 1.5.1

#### Maximum lifting capacity (DIN/ISO/EN)

##### Max. load bearing capacity

- Within the 360° slewing range:<sup>1)</sup> 109 t
- 0° to the rear:<sup>1)</sup> 130 t
- 0° to the rear:<sup>2)</sup> 150 t

##### Max. load moment

- Within the 360° slewing range: 440 tm (55 t x 8 m)

<sup>1)</sup> With additional equipment

<sup>2)</sup> With special equipment (no currently available)

### 1.5.2

#### Maximum lifting capacity (ASME B 30.5)

##### Max. load bearing capacity

- Within the 360° slewing range:<sup>1)</sup> 238 000 lbs
- 0° to the rear:<sup>1)</sup> 286 000 lbs
- 0° to the rear:<sup>2)</sup> 350 000 lbs

##### Max. load moment

- Within the 360° slewing range: 3250 klbs x ft (130 000 lbs x 25ft)

<sup>1)</sup> With additional equipment

<sup>2)</sup> With special equipment (no currently available)

### Auxiliary hoist

Drum diameter:	391 mm (15.39 in)
Rope diameter:	19 mm (0.75 in)
Rope length:	255 m (836 ft)
Rope pull:	76,4 kN/line (17,175 lbf)
Power unit group:	M 3 (to ISO 4301 - 2)
Load spectrum:	L 1
Factor of the load spectrum	Km = 0.125
Theoretical service life:	D = 3,200 h

### Slewing gear

Make:	Siebenhaar
Type:	01 DD
Power unit group	M2 (to ISO 4301 - 2)

### Derricking gear

Cylinder:	Differential cylinder
Adjusting angle (main boom):	-1.54° to + 83° from horizontal position
Power unit group	M2 (to ISO 4301 - 2)

### Main boom

Main boom lengths:	12.8 m to 50.8 m (41.9 ft to 166.7 ft)
Main boom head:	6 sheaves 8 sheaves <sup>1)</sup>
Cylinder:	One single-level telescoping cylinder with locking/unlocking mechanism
Power unit group	M 1 (to ISO 4301 - 2)
Telescoping mechanism:	

<sup>1)</sup> Additional equipment

### Lattice extension

As additional equipment;  *Operating Instructions Lattice Extension.*



The parking brake is used as an example to show how the cross-references guide you through the operating manual.

- A** In this example, the general overview is shown on page 3 - 2.  
The driver's cab is labelled as number **1**. The related table contains a cross-reference in the form
- 1 Driver's cab** ▣▣▣▣▶ p. 3 - 6
- B** Page 3 - 6 shows an interior view of the driver's cab.  
The parking brake is labelled as number **2**. The related table contains a cross-reference in the form
- 2 Parking brake** ▣▣▣▣▶ p. 3 - 59
- C** Page 3 - 59 gives a brief description of all the functions of the parking brake.  
If further information is available, the brief description contains a cross-reference, e.g.
- 4 Test position for towing a trailer:** – Pull the lever down until it locks into place  
– Press in the lever and pull it further downwards  
The parking brake for the trailer is released;  
▣▣▣▣▶ p. 5 - 96.
- D** Follow the cross-reference to pages 5 - 96. Here, the test position of the parking brake when towing a trailer is described in detail, with all requirements and safety instructions.  
There may be additional cross-references here, such as to related pages in the chapter *Malfunctions*.
-

# 2

## Basic safety instructions



Notes on the warnings used;  *What do the symbols used mean?*, p. 1 - 21.

### 2.1

#### Intended use

The GMK5150 truck crane is constructed in accordance with the latest technology and the recognised safety regulations. Nevertheless, the operator or third parties can still be endangered and the crane or other property put at risk while using it.

The truck crane may be modified only with the consent of **Manitowoc Crane Group Germany GmbH**.

The GMK5150 truck crane may be used only when it is in perfect technical condition and for its intended purpose and with due attention paid to safe operation and possible hazards.  
Any malfunctions that could impair safety must be eliminated immediately.

The GMK5150 truck crane may only be operated without the corresponding special equipment within the permitted temperature range;  *Technical data*, p. 1 - 7.

The GMK5150 truck crane is designed solely for lifting loads which are within the permitted GMK5150 lifting capacities. The load must be slung as prescribed to a hook block which is positioned vertically over the load prior to lifting.

**Intended use** also includes

- observing the entire crane documentation, consisting of the operating manual(s), the lifting capacity table, the outrigger pressure table and the safety manual
- adhering to the inspection and maintenance requirements specified in the maintenance manual.

The GMK5150 may only be operated with parts of equipment which approved by **Manitowoc Crane Group Germany GmbH** and which are labelled with the serial number of the GMK5150.

The manufacturer is not liable for any damage caused by improper or unauthorized use of the GMK5150 truck crane. The user shall take on full responsibility for any such use.

Lifting loads simultaneously with two cranes is particularly dangerous. Carry out this type of work with special care.

Always set the load down when there is a break in work, and never leave the truck crane whilst a load is raised.

Whenever you leave the truck crane, secure it against unauthorised use.

After a lightning strike, always have the truck crane checked by **Manitowoc Crane Care** before you drive the truck crane – even if you do not notice any impairment to its function. Electronic components may be damaged by a lightning strike and may fail unexpectedly, either immediately or during later operation.

Crane operation carried out in the vicinity of live electrical cables as well as oil, gas or other supply lines is dangerous and requires special safety measures to be taken. Observe the instructions in the section titled *Crane operation under special operating conditions* in the *Safety manual* and the respective national regulations.

Testing the truck crane by lifting an excessively heavy load (overload testing) is prohibited. This presents the danger of hidden damage that can lead to severe accidents during subsequent crane operation. If locally applicable national regulations require the truck crane to be tested by lifting an excessively heavy load (overload test), always first consult **Manitowoc Crane Care**.

Ramming or pulling sheet-pile walls, sheet piles, beams etc. can damage the truck crane or cause it to tip over.

<b>1</b>	Front flap	▣▣▣▣ p. 3 - 78
<b>2</b>	Driver's cab	▣▣▣▣ p. 3 - 6
<b>3</b>	Installing/removing the hose drum <sup>1), 2)</sup>	
<b>4</b>	Engine for driving	▣▣▣▣ p. 4 - 1
<b>5</b>	Rigging the main boom <sup>1)</sup> ,	▣▣▣▣ p. 6 - 17
<b>6</b>	Installing/removing the auxiliary hoist <sup>1)</sup>	▣▣▣▣ p. 6 - 41
<b>7</b>	Spare wheel <sup>1)</sup>	▣▣▣▣ p. 1 - 10
<b>8</b>	APS connection/interface (Auxiliary Power Supply) <sup>1), 3)</sup>	
<b>9</b>	BirdView system 270° <sup>1)</sup>	▣▣▣▣ p. 3 - 55
<b>10</b>	Chocks <sup>1)</sup>	▣▣▣▣ p. 5 - 54
<b>11</b>	Folding ladder	▣▣▣▣ p. 4 - 6
<b>12</b>	– Outriggers, operation	▣▣▣▣ p. 12 - 29
	– Outrigger lighting on/off <sup>1)</sup>	▣▣▣▣ p. 3 - 69
<b>13</b>	Ladders	▣▣▣▣ p. 4 - 5
<b>14</b>	– Fuel tank	▣▣▣▣ p. 4 - 7
	– Dual tank <sup>1)</sup>	▣▣▣▣ p. 4 - 8
<b>15</b>	– Outriggers control units	▣▣▣▣ p. 3 - 38
	– Emergency stop switches	▣▣▣▣ p. 4 - 22

1) Additional equipment

2) ▣▣▣▣ *Operating Instructions Lattice Extension*

3) ▣▣▣▣ *Separate operating instructions*



### 3.1.4

## Instrument panel

Left/right

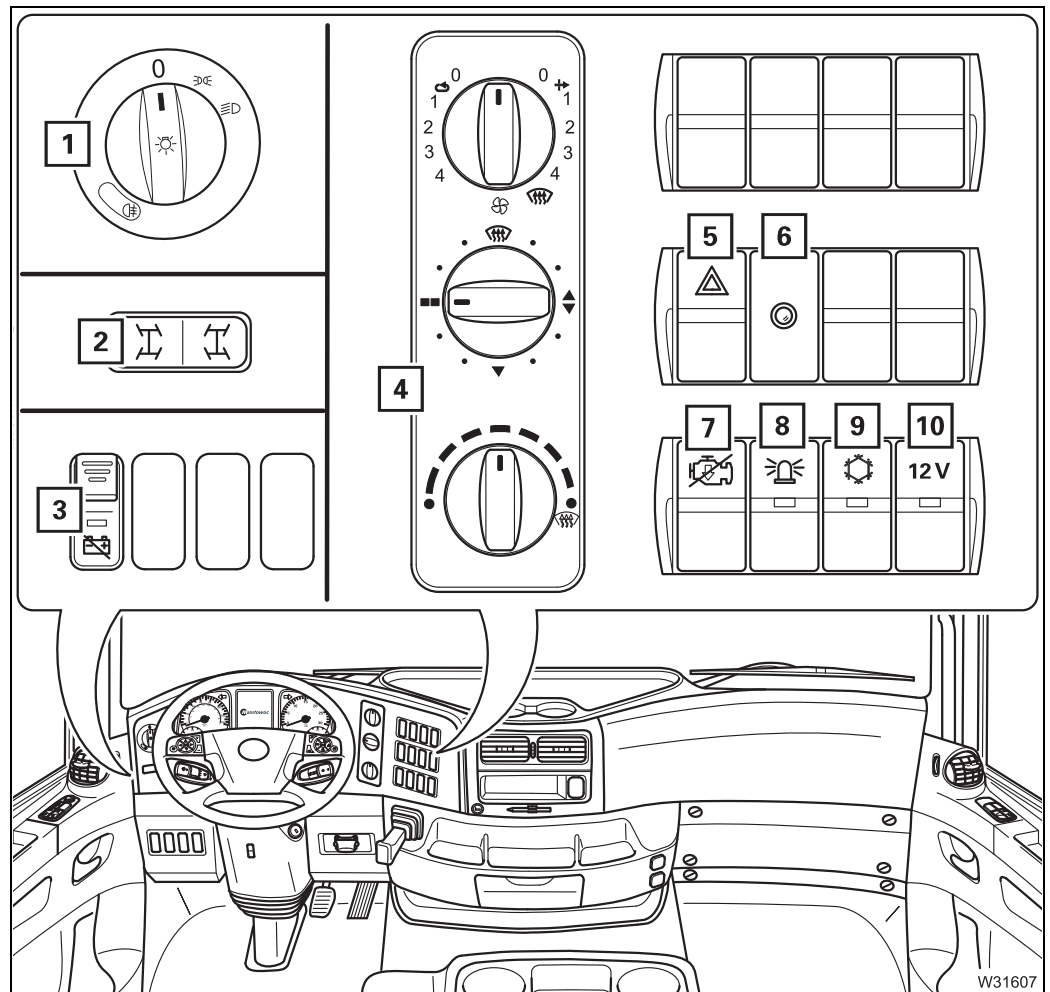

- |   |             |
|---|-------------|
| 1 Lighting on/off                       | ➡ p. 3 - 68 |
| 2 Separate manual steering              | ➡ p. 3 - 63 |
| 3 Battery master switch                 | ➡ p. 3 - 49 |
| 4 Heating system                        | ➡ p. 3 - 19 |
| 5 Hazard warning system on/off          | ➡ p. 3 - 68 |
| 6 Dual tank check                       | ➡ p. 4 - 8  |
| 7 Torque reduction override button      | ➡ p. 3 - 48 |
| 8 Rotating beacons on/off               | ➡ p. 3 - 69 |
| 9 Air-conditioning system <sup>1)</sup> | ➡ p. 3 - 19 |
| 10 12 V power socket on/off             | ➡ p. 3 - 50 |

<sup>1)</sup> Additional equipment



### 3.1.10

## CCS display – Start menu

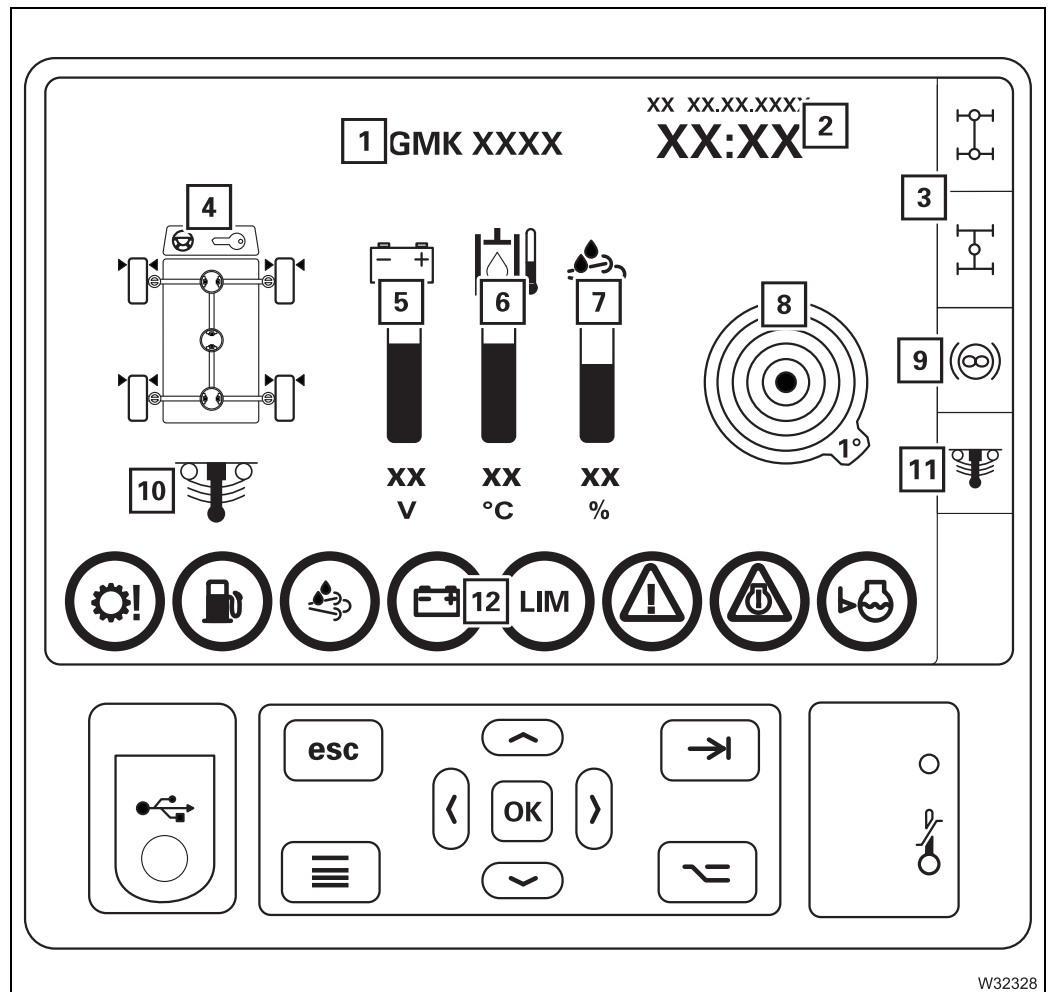

W32328

- |  |                |
|--|----------------|
| <b>1</b> Display of crane type                         |                |
| <b>2</b> Date/time display                             | ▣▣▣▣ p. 3 - 30 |
| <b>3</b> Transverse differential locks display         | ▣▣▣▣ p. 3 - 58 |
| Longitudinal differential lock display                 | ▣▣▣▣ p. 3 - 59 |
| <b>4</b> – Transverse differential locks on/off        | ▣▣▣▣ p. 3 - 28 |
| – Longitudinal differential lock on/off                |                |
| – Steering locking status display                      |                |
| <b>5</b> Voltage monitoring display                    | ▣▣▣▣ p. 5 - 52 |
| <b>6</b> Hydraulic oil temperature display             | ▣▣▣▣ p. 5 - 52 |
| <b>7</b> AdBlue level display                          | ▣▣▣▣ p. 5 - 53 |
| <b>8</b> Current inclination display                   | ▣▣▣▣ p. 3 - 71 |
| <b>9</b> Display of retarder function on/off           | ▣▣▣▣ p. 5 - 43 |
| <b>10</b> Suspension display                           | ▣▣▣▣ p. 3 - 27 |
| <b>11</b> Suspension on/off display                    | ▣▣▣▣ p. 3 - 27 |
| <b>12</b> Warning message / error message display area | ▣▣▣▣ p. 3 - 44 |

## Operating hours menu

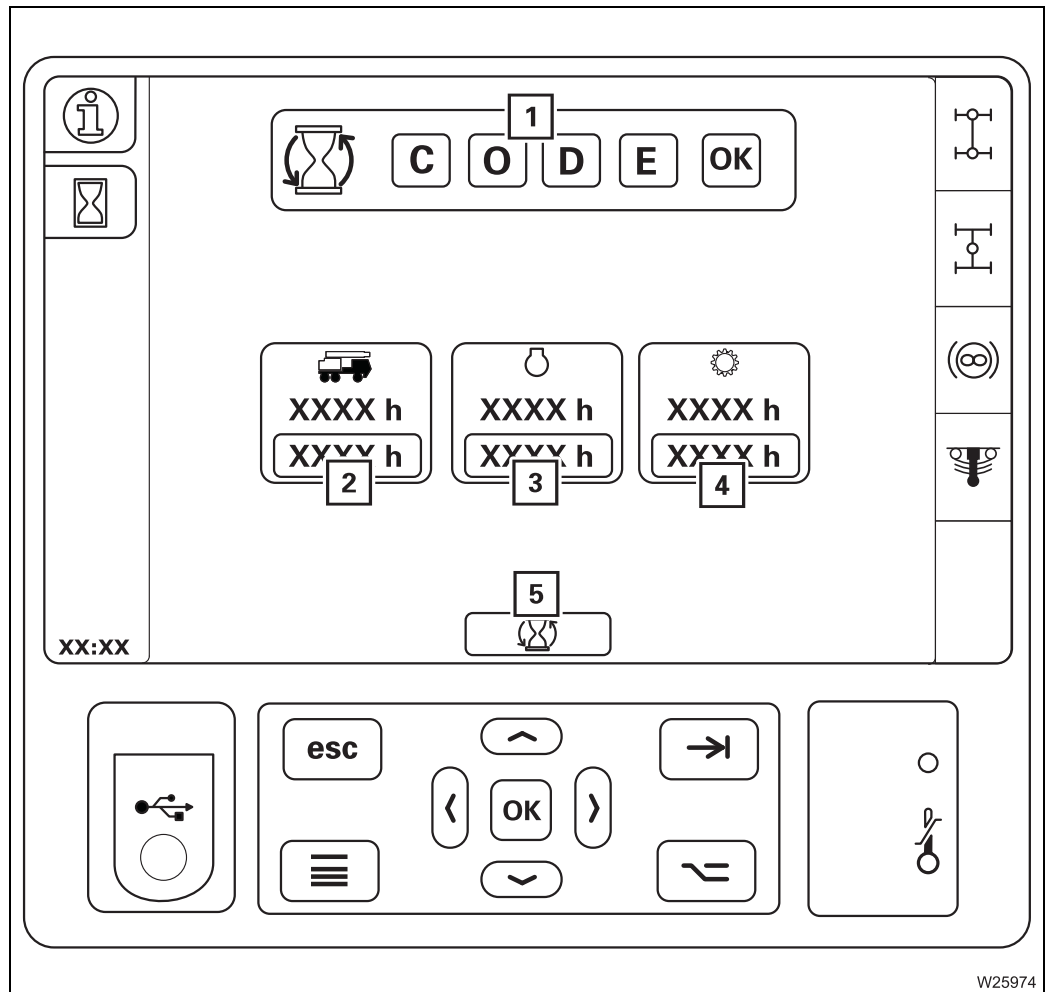

W25974

- |                        |                |
|------------------------|----------------|
| <b>1</b> Keycode input | ▣▣▣▣ p. 5 - 24 |
| <b>2</b> Transmission  | ▣▣▣▣ p. 5 - 24 |
| <b>3</b> Engine        | ▣▣▣▣ p. 5 - 24 |
| <b>4</b> Selection all | ▣▣▣▣ p. 5 - 24 |



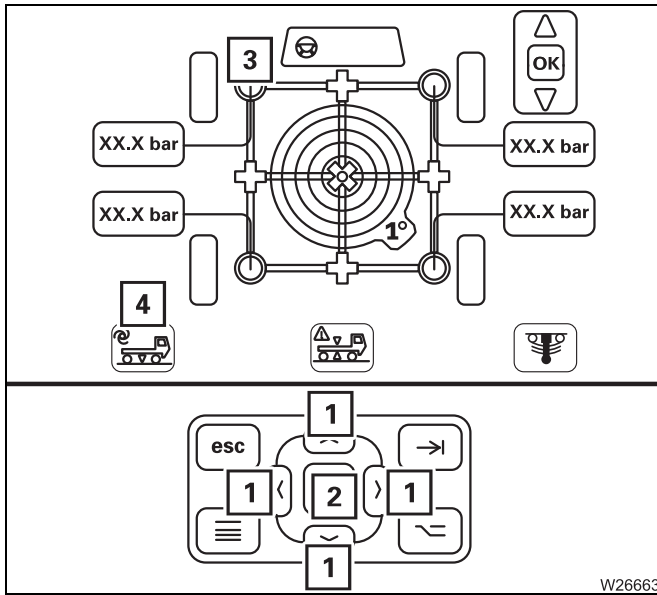

### Functions in the Operation area

Executing a movement

– Select function

**1 Press**

– The marked function (3) or (4) is selected.

– Move function

**2 Press**

– The selected function is carried out.

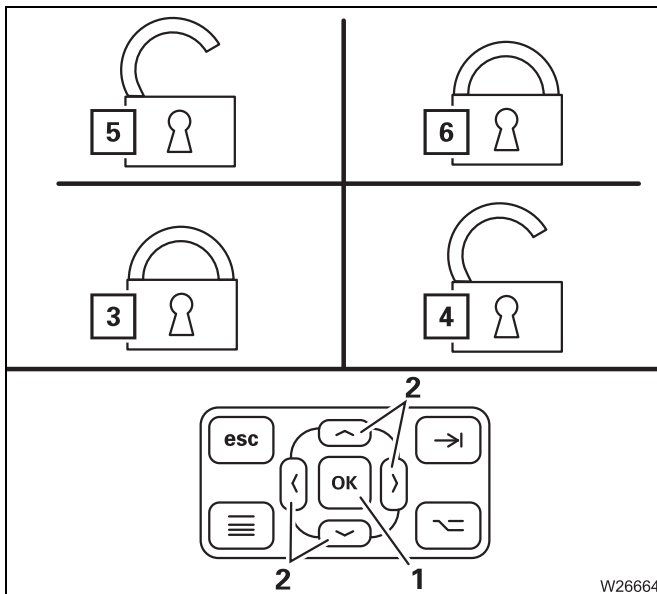

### Turning on/off and switching

– Selecting status

**2 Press**

– The marked state (3) or (5) is selected.

– Switch on state

**1 Press**

– The selected state (4) or (6) is established.



## Display driving mode

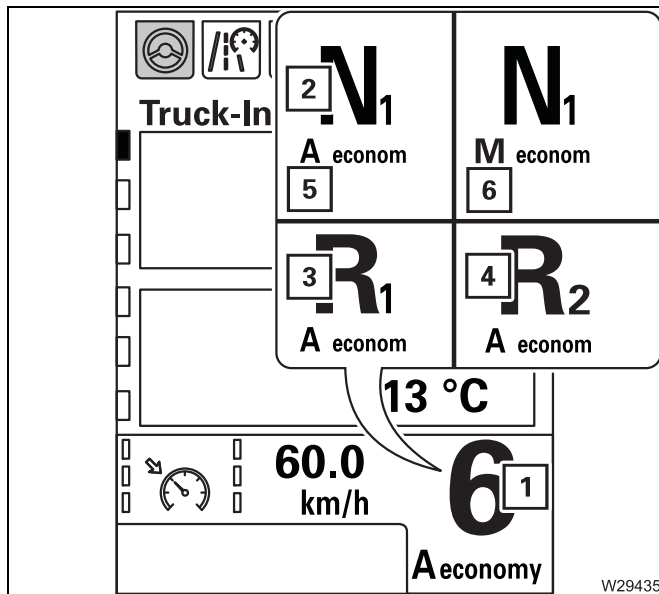

### Transmission display

- 1 Currently engaged gear – forwards (1 to 16), e.g. 6
- 2 Neutral position switched on
- 3 Gear currently engaged – 1st reverse gear
- 4 Gear currently engaged – 2nd reverse gear
- 5 *Automatic* operating mode
- 6 *Manual* operating mode

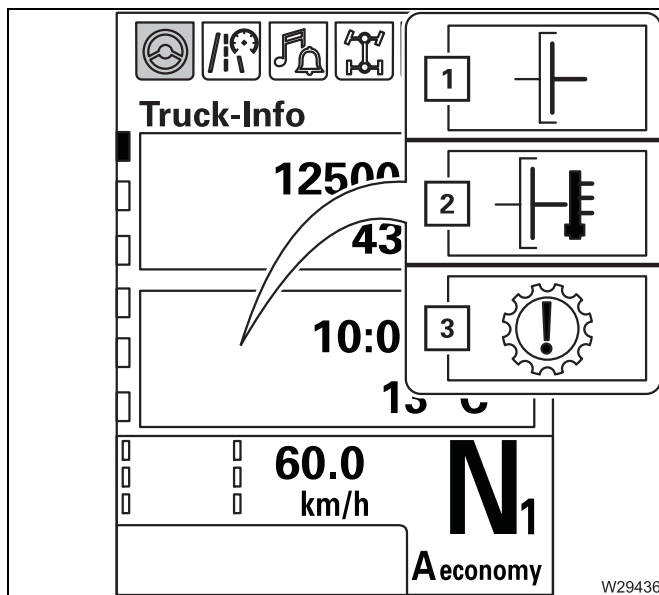

### Error messages display

- 1 Clutch heavily loaded
- 2 Clutch malfunction
- 3 Gear shift malfunction

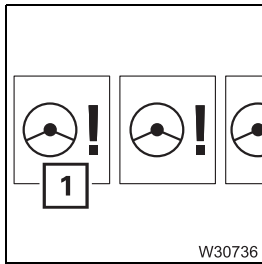

### Steering system warning

- **On:** Steering system faulty – stop immediately, Display symbol (1) – 4th and 5th axle cannot be steered; if it is possible, it can only be steered in straight running position – max 20 km/h (12 mph)
- **Off:** No error in the steering system

After engine start;  p. 4 - 17

While driving;  p. 5 - 35

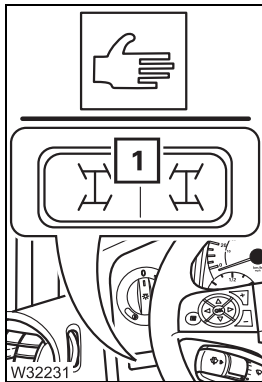

### Separate manual steering

The separate manual steering must be switched on.

Steer the 1st and 2nd axle lines with the steering wheel.

Press button (1) and keep it depressed

- **To the left:** 4th and 5th axle line – turn to the left
- **To the right:** 4th and 5th axle line – turn to the right

 p. 5 - 69



### 3.2.19

## Diagnostics

The diagnostics connections may only be operated by service staff from the engine manufacturer/transmission manufacturer, or by **Manitowoc Crane Care**.

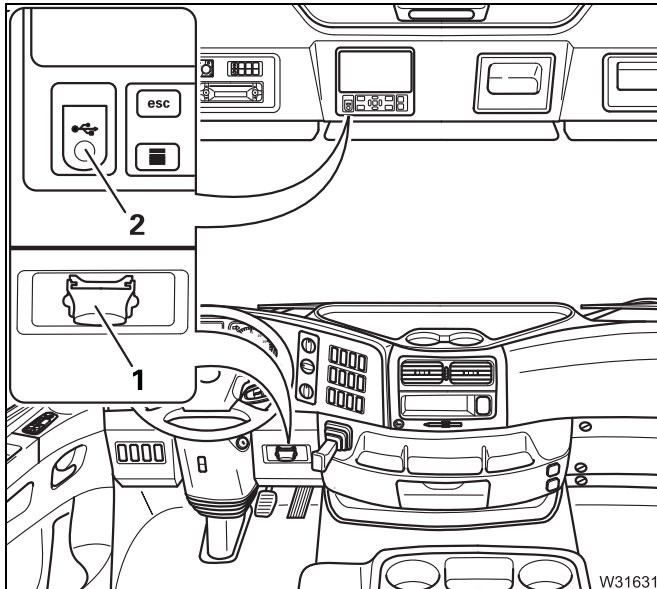

The following connections are under the cover (4).

- 1 Carrier electronics diagnostics
- 2 Transmission diagnostics
- 3 Engine diagnostics

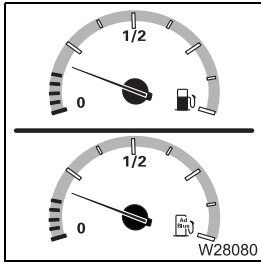

**10. Check the fluid supply:**

- ■■■▶ *Fuel tank*, p. 4 - 7,
- ■■■▶ *AdBlue tank*, p. 4 - 9
- ■■■▶ *Fuel tank auxiliary heater*, p. 11 - 5

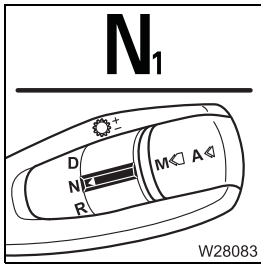

**11. Shift the transmission to neutral position; ■■■▶ p. 5 - 26.**

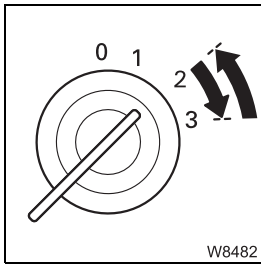

**12. Start the engine; ■■■▶ p. 4 - 14.**

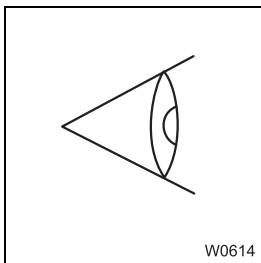

**13. Conduct the necessary checks after starting the engine; ■■■▶ p. 4 - 16.**

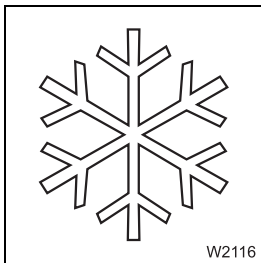

**14. In the event of low outside temperatures; ■■■▶ *CHECKLIST: At low temperatures*, p. 4 - 4.**

## 4.1.8

### Display brightness

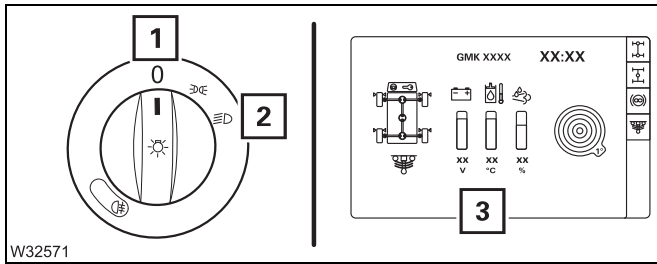

The CCS display automatically regulates the brightness of the displays.

- 1 Headlight off:** Display (3) bright
- 2 Headlight on:** Display (3) dark

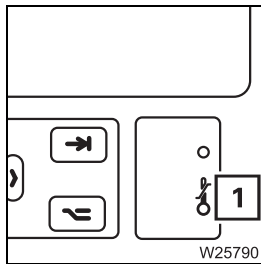



If the temperature on the display is too high, the brightness is reduced automatically – lamp (1) lights up.

When the temperature falls, the specified brightness is restored – lamp (1) goes out.

## 4.3

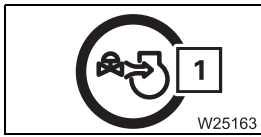
## Air intake inhibitor



If the air intake inhibitor is triggered, a flap in the air intake line will close and the engine will stop running – symbol (1) **red** – in the start menu display area;  p. 8 - 41.

The air intake inhibitor is triggered,

- if an emergency stop switch is actuated or
- when the maximum permissible engine speed is exceeded. In this case, the symbol (1) will turn **red** – in the start menu display area;  p. 8 - 41.



The symbol stays **red** until the ignition has been switched off.

The engine can be restarted only after the air intake inhibitor has been released.

### Releasing the air intake inhibitor

The following requirements must be met in order to release the air intake inhibitor:

- The ignition must be switched off.
- The emergency stop switch must be reset.

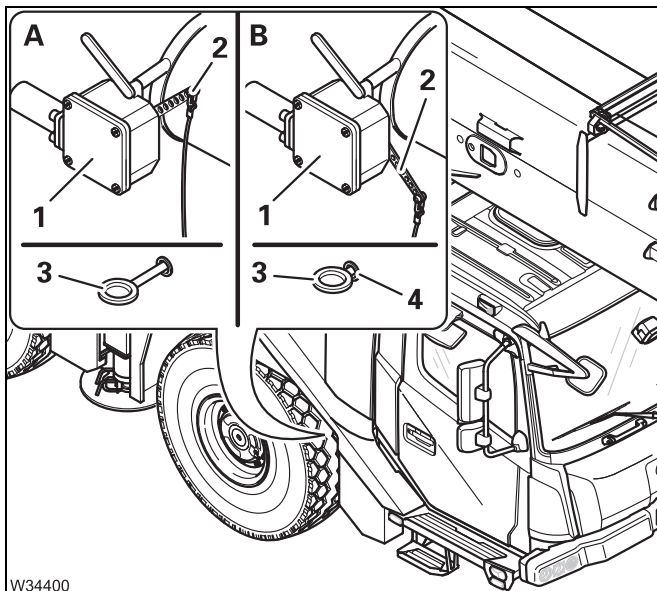

The indicator (2) shows the current state of the air intake inhibitor (1).

(A) – The indicator (2) is in the *closed* position.

- Pull as far as possible on the handle (3).

(B) – Insert the handle (3) back into the holder (4) – in the *released* position.

## 5.1.2

### Checking the condition of the truck crane

#### Electrical system

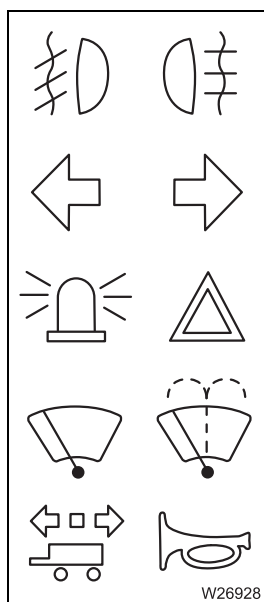

- Check the following functions and arrange for faulty parts to be repaired:
  - Parking light/headlight, rotating beacons, fog tail light, side marker lights,
  - Hazard warning system,
  - Brake lights,
  - Reversing lamp/buzzer,
  - Full-beam headlight,
  - Turn signal indicators,
  - Windscreen wipers,
  - Windscreen washing system,
  - Horn.

#### Adjust the mirrors

Adjust all the mirrors to suit your sitting position.

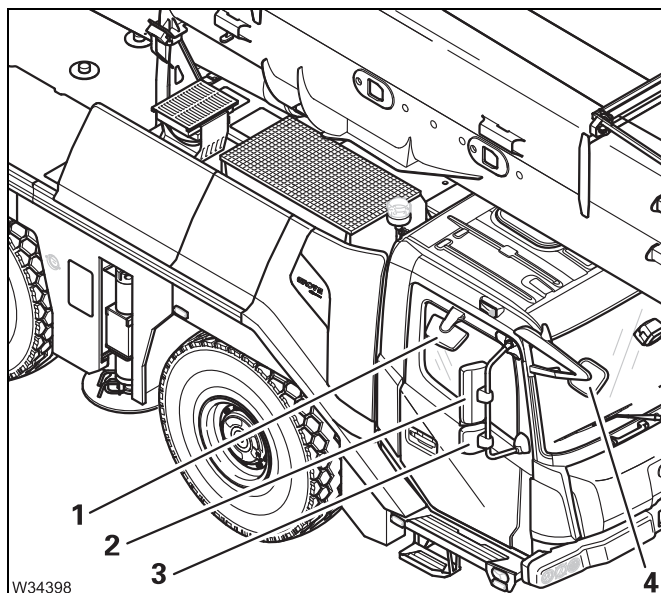

#### Manual adjustment

- Manually adjust the mirrors (1), (3) and (4).

The mirrors (2) are adjusted electrically on both sides.



### Switching the suspension on

The suspension cylinders are enabled when the suspension is switched on. This state must be established for on-road driving.



#### **Danger of overturning when switching on the suspension!**

Do not switch the suspension on unless the truck crane has been rigged for on-road driving and the main boom has been set down. If the rigged truck crane was standing on its wheels the suspension struts would be suddenly pushed together when the suspension was switched on, causing them to be damaged and possibly causing the truck crane to overturn.

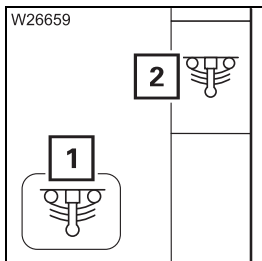

- Select and confirm the symbol (1).

When the suspension is switched on, the symbol (2) is **green**.

If the symbol (2) remains **red**, the supply pressure may be too low. In this case the suspension would not be switched on until sufficient supply pressure has been built up; *Building up supply pressure*, p. 5 - 10.

### Switching off the suspension

When the suspension is switched off, the suspension cylinders are locked. This state is intended only for crane operation.



#### **Risk of damage to the axle lines!**

Always switch the suspension on for on-road driving. The axle lines may become damaged and the steering behaviour may change if the suspension is switched off.

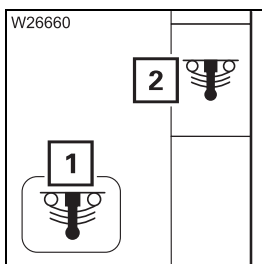

- Select and confirm the symbol (1).

When the suspension is switched off, the symbol (2) is **red**.

### 5.2.3

## Selecting the direction of travel and starting gear

### Selecting the driving direction

Before driving at temperatures below  $-20\text{ }^{\circ}\text{C}$  ( $-4\text{ }^{\circ}\text{F}$ );  p. 5 - 34.

The following requirements must be met before selecting the driving direction:

- the truck crane is stationary,
- the parking brake is applied,
- the accelerator is not pressed.

- Start the engine;  p. 4 - 14.

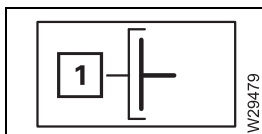

If the supply pressure is insufficient for shifting the transmission, the display will show the symbol (1). A corresponding message is also displayed. If necessary, wait until the supply pressure has built up, and the message disappears;  *Building up supply pressure*, p. 5 - 10.

- Release the accelerator.



#### Risk of accidents from uncontrolled starting!

When you press the accelerator, the clutch is engaged immediately after the start-up gear is (automatically) selected, and the truck crane will start to move.

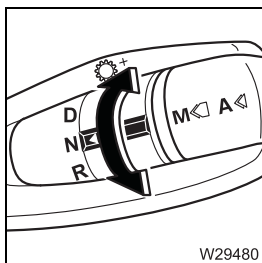

- In order to
  - for **forward travel** in position **D**.
  - for **reverse travel** in position **R**. An acoustic signal sounds if additional equipment is present.

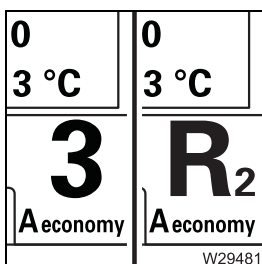

The *Automatic* operating mode is now selected. An appropriate starting gear is selected and displayed:

- For forward travel, e.g. 3rd gear,
- For reverse travel, e.g. 2nd gear.

The clutch is not engaged (only when you press the accelerator).



### Lamps for the ABS system

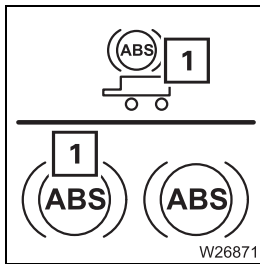

- Check the lamps (1).

At speeds of above 6 km/h (4 mph), the lamps (1) **must** go out. Then the **Anti-Blocking-System (ABS)** is operational and the wheels are prevented from being blocked when you brake.

If a lamp does not go out, the corresponding ABS system is faulty, and the wheels will no longer be prevented from blocking. The full braking force remains intact; *Malfunctions of the service brake*, p. 8 - 39.

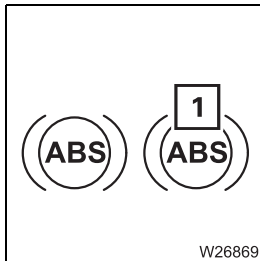

If the lamp (1) lights up, then the braking operation is supported by the ABS system.

### While driving

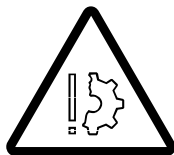

- Observe all warning messages.

#### Risk of damage if warning messages are disregarded!

Once a warning message appears (on the *CCS display* or *combination instrument display*), always promptly observe all information in the section titled *Warnings in the start menu*, and take the appropriate corrective measures. This prevents these malfunctions causing defects in the truck crane.

### On the instrument panel

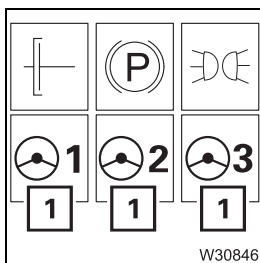

- If one of the lamps (1) which has already been checked lights up again, refer to the information in the previous section.

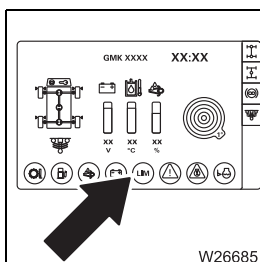

- If the CCS display shows a warning message (1); *Warnings in the start menu*, p. 5 - 52.





### Steering circuit 3 warning (emergency steering pump)

Malfunction in steering circuit 3 – check for loss of oil; *Malfunctions of the steering, p. 8 - 38.*

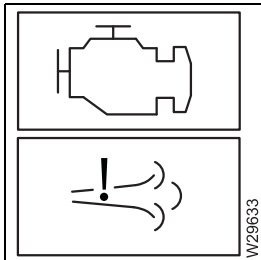

### AdBlue system

- Also check the control elements for the Adblue system;

*Faults on the Adblue system, p. 8 - 35.*

## 5.3.7

### Messages on the on-board computer display

Messages are shown automatically. There are three types of message.

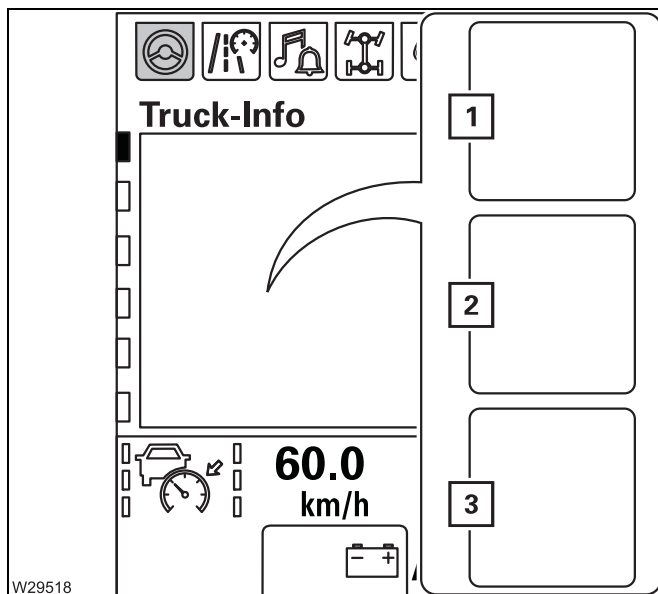

#### - Warning message

Display (1) **red**, additional text and symbols.

- Stop as quickly as possible, taking account of the traffic situation.

#### - Fault message

Display (1) **yellow**, additional text and symbols.

- Check the cause when you next stop, or stop if the text requests you to do so.

#### - Information

Display (1) **grey**, additional text and symbols.

- Pay attention to the messages. You can continue driving.





## 5.4

### Off-road driving

This section describes adjustments, connections and procedures for adapting the vehicle handling to off-road conditions.



#### Adjustments to the transmission

If you drive continuously for short periods of time with different loads or on a slippery surface, the transmission may switch gears too late or too early. In this event you can make the following adjustments:

- Shift to a lower starting gear;  p. 5 - 28.
- Step on the accelerator as far as it will go when starting – starting mode for load on.
- Select the *Manual* operating mode. This will allow you to drive carefully and promptly shift gears;  p. 5 - 29.

#### Connections

If the adjustments to the transmission are insufficient on their own, you can additionally connect the following one after the other:

- Then switch on the **longitudinal differential lock**;  p. 5 - 59.
- Then switch on the **transverse differential lock**;  p. 5 - 59.

#### Changing the vehicle level

You can also adapt the truck crane to the off-road inclination using the level adjustment system, or lift and lower the truck crane;  p. 5 - 61.

#### Rocking the vehicle free and towing

If the truck crane is stuck in terrain;  *Freeing an immobilized truck crane*, p. 5 - 65.

## 5.5

### Separate steering

There are two steering modes with separate steering.

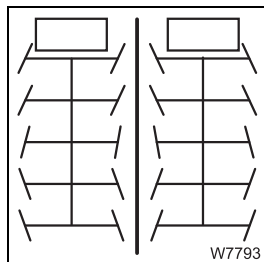

– **Driving around corners:**

When the separate steering is switched on, the steering angle is larger than for normal steering mode – the turning circle is smaller.

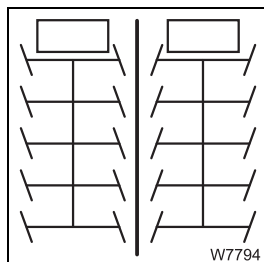

– **Crab travel mode:**

When the separate steering is switched on, the truck crane drives sideways if you turn the wheels of the front and rear axle lines in the same direction.

## Cooling

The illustration shows only a sample setting. Always adjust the setting to the current conditions.

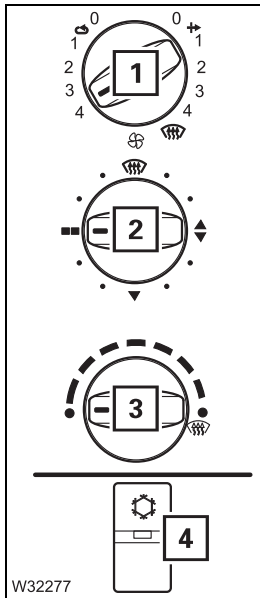

- Switch the air-conditioning on – the lamp (4) lights up.
- Turn the switch (3) as far as it will go, to *Cold*.
- Turn the switch (1) to the desired level – with recalculated air, you will be able to cool more quickly, but no oxygen is fed in.
- Set the air distribution with switch (2) – open the air vents if necessary; p. 5 - 74.
- Close the push-up roof; p. 3 - 75.

## Drying

You can dry the air in the driver's cab.

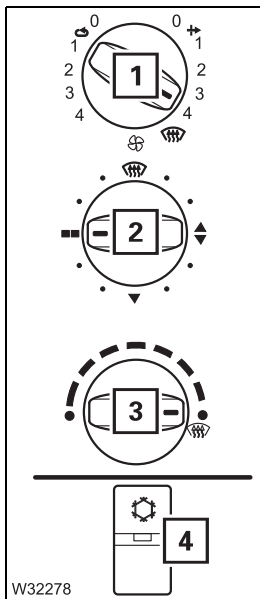

- Switch the air-conditioning on – the lamp (4) lights up.
- Turn the switch (3) as far as it will go, to *Warm*.
- Turn the switch (1) to the desired level – adjust the fresh air/recalculated air setting to the current conditions (humidity and temperature of the outside air).
- Set the air distribution with switch (2) – open the air vents if necessary; p. 5 - 74.
- Close the push-up roof; p. 3 - 75.

When drying, the air-conditioning system and the heating system work against each other. After drying, switch off the device that you do not require.

### Setting the day and time

Always set the current time and current day of the week. These settings are required for the correct activation point of the automatic heating start.

If the electric power supply is interrupted, you have to reset the time and day of the week.

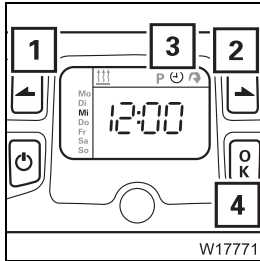

- Use button (1) or (2) to select the symbol (3) and confirm with button (4).  
The set day of the week is shown in the program column.
- Select the day of the week using button (1) or (2) and confirm with button (4).

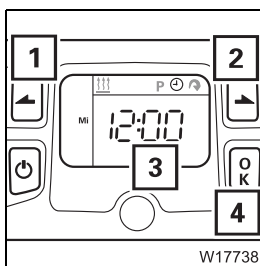

The set time is shown in display row (3).

- Select the hour using button (1) or (2) and confirm with button (4).
- Select the minutes using button (1) or (2) and confirm with button (4).

### Setting the preselection time

Heating is started automatically on schedule only if the time and the day of the week have been correctly set;  *Setting the day and time*, p. 5 - 87.

You can set three different preselection times – up to seven days in advance.



The set preselection times are departure times. Depending on the heating period set, the heating switches on accordingly beforehand.

### Setting the departure times

- Use button (1) or (2) to select the symbol (3) and confirm with button (4).

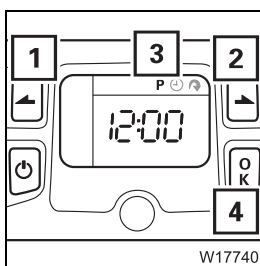

## 6 Driving modes

<b>6.1</b>	<b>Driving modes</b> . . . . .	6 - 1
6.1.1	How to use the tables: . . . . .	6 - 2
6.1.2	Table for a maximum axle load of 12 t (26,500 lbs). . . . .	6 - 3
6.1.3	Maximum permitted speeds with an axle load of over 12 t (26 500 lbs) . . . . .	6 - 6
<b>6.2</b>	<b>Weighing the truck crane</b> . . . . .	6 - 7
<b>6.3</b>	<b>Rigging work for driving with a trailer</b> . . . . .	6 - 11
6.3.1	Switching on the slewing gear freewheel . . . . .	6 - 12
6.3.2	Switching on the boom floating position . . . . .	6 - 13
6.3.3	Switching on boom pre-tensioning. . . . .	6 - 14
6.3.4	Raising/lowering the 3rd axle line for towing a trailer . . . . .	6 - 15
<b>6.4</b>	<b>Rigging the main boom</b> . . . . .	6 - 17
6.4.1	CHECKLIST: removing the main boom . . . . .	6 - 18
6.4.2	CHECKLIST: installing the main boom . . . . .	6 - 21
6.4.3	Slinging the main boom. . . . .	6 - 24
6.4.4	Switching the pressure relief on/off . . . . .	6 - 26
6.4.5	Retracting/fitting the derricking cylinder head pin . . . . .	6 - 27
6.4.6	Extending/retracting the boom pivot pin . . . . .	6 - 30
6.4.7	Removing/attaching the clamps . . . . .	6 - 34
6.4.8	Disconnecting/connecting hydraulics/electrical . . . . .	6 - 35
6.4.9	Aligning the connecting points . . . . .	6 - 37
6.4.10	Securing/releasing the derricking cylinder . . . . .	6 - 38
6.4.11	Transporting the main boom. . . . .	6 - 38
6.4.12	Inspections after main boom mounting . . . . .	6 - 39
<b>6.5</b>	<b>Installing/removing the auxiliary hoist</b> . . . . .	6 - 41
6.5.1	Slinging the auxiliary hoist . . . . .	6 - 41
6.5.2	CHECKLIST: Installing the auxiliary hoist . . . . .	6 - 42
6.5.3	CHECKLIST: Removing the auxiliary hoist . . . . .	6 - 43
6.5.4	Making/breaking the connection between the auxiliary hoist and the turntable . . . . .	6 - 44
6.5.5	Establishing/disconnecting the hydraulic connection . . . . .	6 - 45
6.5.6	Establishing/disconnecting the electrical connection . . . . .	6 - 46
6.5.7	Making/breaking the connection to the central lubrication. . . . .	6 - 47
6.5.8	Transporting the auxiliary hoist . . . . .	6 - 48
6.5.9	Check that the auxiliary hoist is functioning properly. . . . .	6 - 49

## Weighing procedure

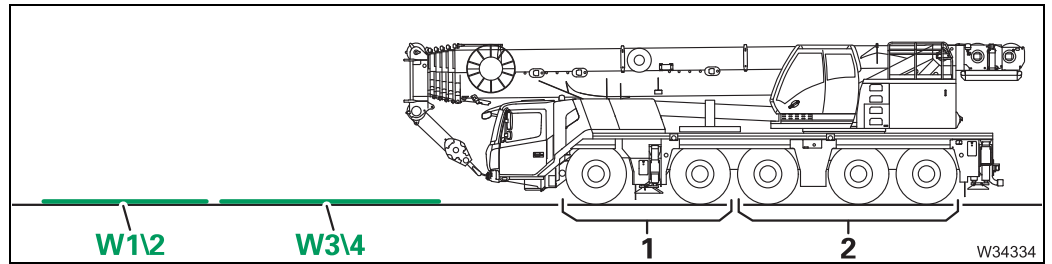

**Perform the weighing procedure only with the crane truck standing on solid and horizontal ground. All scales must be at the same height.**

- Position the scales **W1** to **W4** (or the necessary support plate) directly in front of the truck crane, so that the distances between the scales are exactly the same as the distances between the axle groups **1** and **2**.

In the next step, drive at only a very low speed without any steering movements, and brake only very gently.

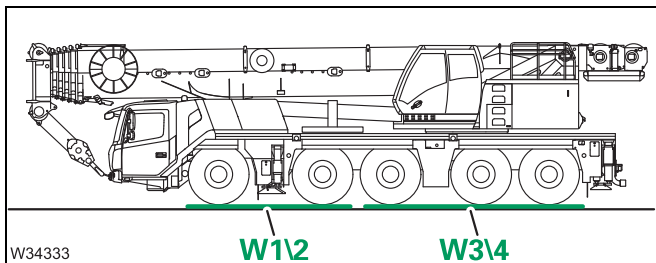

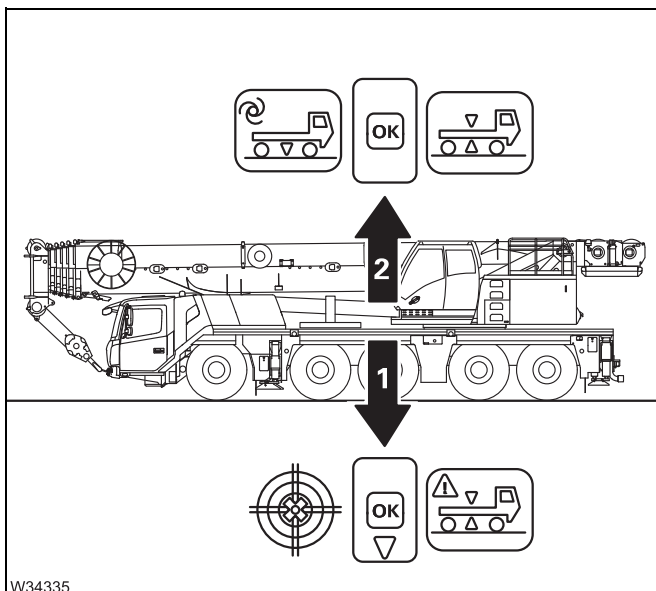

- Drive the truck crane on to the scales **W1** to **W4** (or on to the necessary support plates), so that the axle groups stand centrally on the scales.
- **Do not** apply the parking brake.



- If the truck crane has to be braked while changing the level, only use the service brake very gently.
- (1) – Use the level adjustment system to lower the truck crane to its lowest position; p. 5 - 16.
- (2) – Use the **automatic function** to set the level for on-road driving. If you move the axle groups individually the weighing result will be falsified.
- Read the scales and make a note of the results.

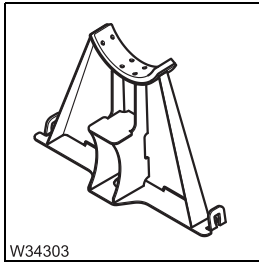



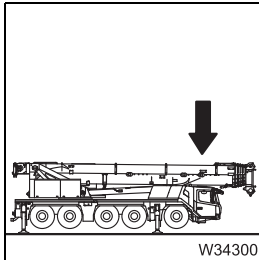

3. Place the derricking cylinder support on the counterweight platform;  p. 6 - 27.

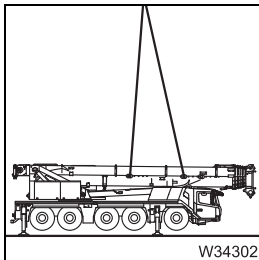

4. Place the main boom on the boom rest.



5. Sling the main boom to an auxiliary crane;  p. 6 - 24.

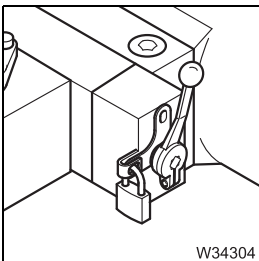

6. Switch on the derricking cylinder pressure relief;  p. 6 - 26.

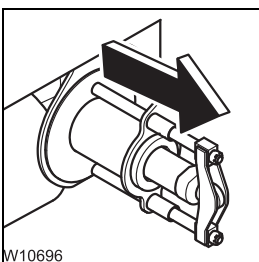

7. On the derricking cylinder head axle:
- Take the load off of the head pin
  - Release the head pin
  - Pull the head pin out;
-  p. 6 - 27.



### Fitting the derricking cylinder head axle

- Check to see if the tightening belt of the derricking cylinder is taken off.

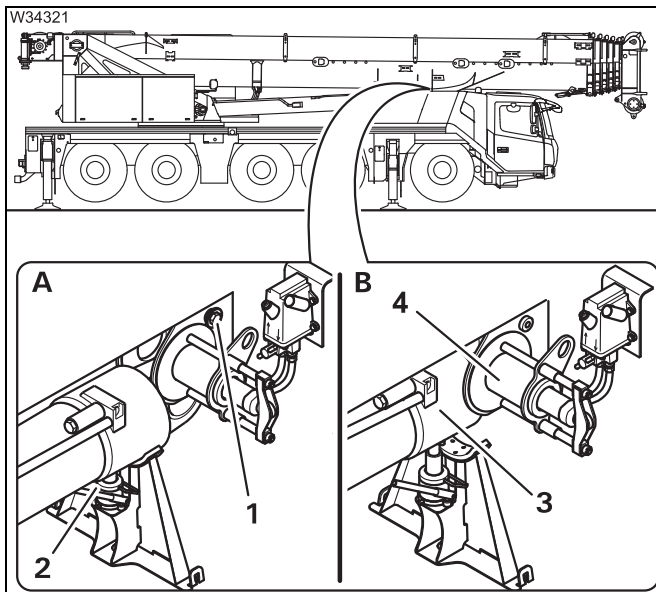

### Aligning the derricking cylinder

- (A) – Remove the bolt (1) and remove the disc.
- Place the lifting device (2) underneath the middle of the derricking cylinder.
- (B) – Carry out the *Raise* movement until the head pin (4) is aligned with the bearing in the derricking cylinder (3).



### Risk of damage to the bearings in the derricking cylinder head

Make sure that the bearings in the derricking cylinder are aligned with the head pin before fitting the head pin.

This prevents the head pin from damaging the bearing.

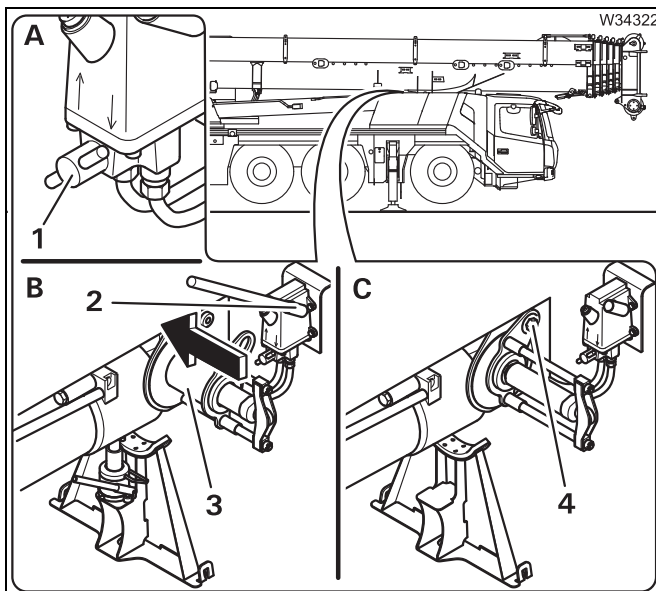

### Fitting the head pin

- (A) – Turn the switch (1) to the *Plug*  position.
- (B) – Insert the lever into the clamp (2)
- Pump until the head pin (3) is inserted as far as possible.

### Securing the head pin

- (C) – Fasten the disc with the bolt (4)
- Stow away the lever and the lifting device so that it is safe to drive on the road.

## 6.4.12

### Inspections after main boom mounting

- Check to see if the pressure relief is switched off and is secured with the lock;  p. 6 - 26.

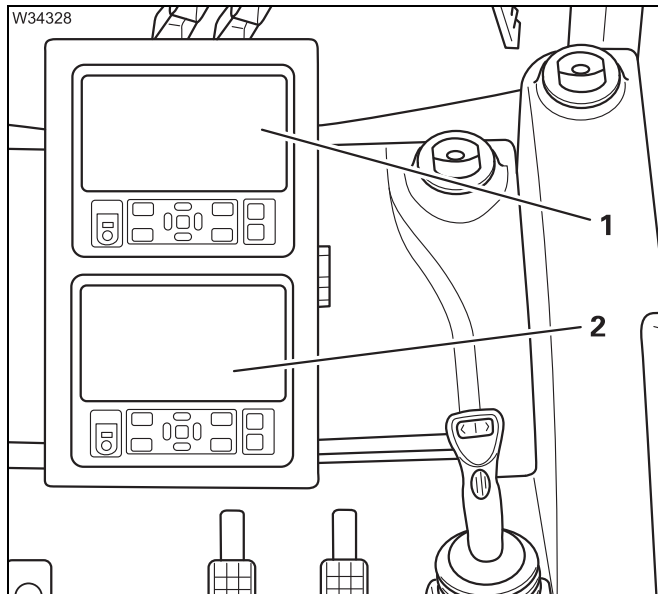

- Switch on the ignition.
- Check if the *RCL* (1) or *CCS* (2) control unit shows an error message.
- If an error message is displayed, check that all electrical connections are established;  p. 6 - 35.

The following requirements must be met for the subsequent inspection:

- The truck crane is supported on outriggers.
- The main boom must be resting in the boom rest.
- The current rigging mode is entered on the RCL.

- Telescope the telescopic section approx. 1 m out and back in.
- Retract the telescoping cylinder into another telescopic section and mechanically lock it there.
- Check to see if the hydraulic connections in the turntable are sealed.



Before operating for the first time, carry out the movement *Incline lattice extension* with the hydraulically derricking lattice extension and check if the corresponding connections in the turntable are sealed.

Installing/removing the hose drum requires using an auxiliary crane with sufficient load-bearing capacity. The weight of the hose drum is approx. 170 kg (375 lbs).

## 6.5.9

### Check that the auxiliary hoist is functioning properly.

#### Slewing direction

Check the slewing direction before laying on the hoist rope.



#### Risk of accidents due to incorrect slewing direction

Check after each installation that the slewing direction is correct.

This prevents accidents caused by the hoist rope winding up unexpectedly when it is applied.



#### Danger due to slack rope

Only drive the auxiliary hoist briefly and at the lowest speed.

This prevents slack rope from being created, or rope end clamps being pulled into the hoist frame.

Ask someone to observe the slewing direction for you, or stand next to the auxiliary hoist and use the hand-held control.

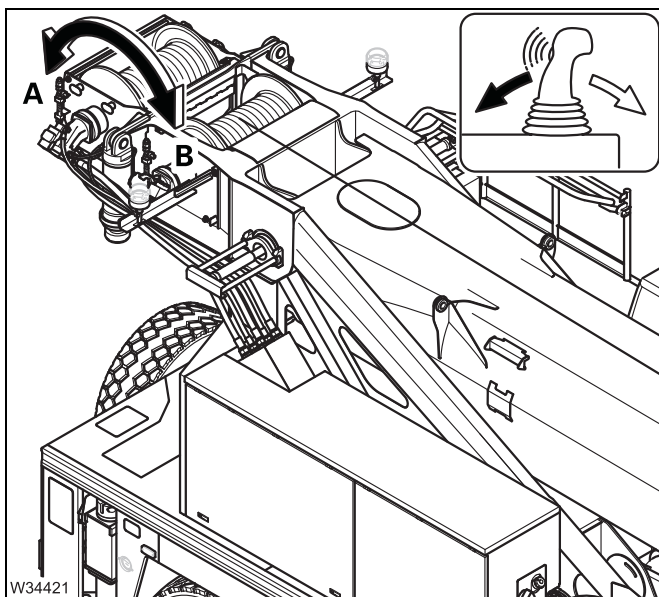

- Drive slowly, and complete the *lift* and *lower* movements – stop the movement as soon as the hoist drum turns.

- Check that the slewing direction is correct:

- A** Lifting
- B** Lowering

#### Slewing indicator

Check the function of the slewing indicator when applying the hoist rope.

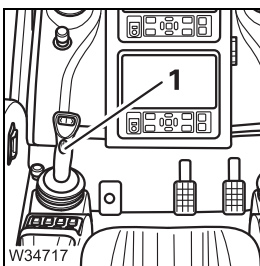

- You have to feel a pulse on the slewing indicator (1) when the auxiliary hoist is rotating;
- If no pulse is present, contact **Manitowoc Crane Care**.

## 8 Malfunctions in driving mode

<b>8.1</b>	<b>Emergency stop switches</b> .....	8 - 1
<b>8.2</b>	<b>What to do when a malfunction occurs in road traffic</b> .....	8 - 3
<b>8.3</b>	<b>Towing away the truck crane</b> .....	8 - 5
8.3.1	Towing after engine/transmission damage .....	8 - 6
8.3.2	Tow starting .....	8 - 9
<b>8.4</b>	<b>Other emergency operations</b> .....	8 - 11
8.4.1	Externally starting the truck crane .....	8 - 11
8.4.2	Battery charger .....	8 - 12
<b>8.5</b>	<b>Wheels and tyres</b> .....	8 - 13
8.5.1	Wheel change .....	8 - 13
8.5.2	Inflating the tyres yourself .....	8 - 17
<b>8.6</b>	<b>Tilting/lowering the driver's cab</b> .....	8 - 19
8.6.1	Prerequisites and information on tilting .....	8 - 19
8.6.2	Tilting/lowering the driver's cab .....	8 - 20
<b>8.7</b>	<b>Fuses on the carrier</b> .....	8 - 25
8.7.1	Fuses in the driver's cab .....	8 - 26
8.7.2	Fuses in the battery box .....	8 - 32
<b>8.8</b>	<b>Troubleshooting</b> .....	8 - 33
8.8.1	Malfunctions on the engine .....	8 - 33
8.8.2	Faults on the Adblue system .....	8 - 35
8.8.3	Malfunctions of the differential locks .....	8 - 36
8.8.4	Malfunctions in the transmission .....	8 - 37
8.8.5	Malfunctions of the steering .....	8 - 38
8.8.6	Malfunctions of the service brake .....	8 - 39
8.8.7	Malfunctions on the suspension .....	8 - 40
8.8.8	Malfunctions of the level adjustment system .....	8 - 40
8.8.9	Malfunctions in the hydraulic system/hydraulic oil cooler .....	8 - 40
<b>8.9</b>	<b>CCS warning/error message</b> .....	8 - 41
8.9.1	Engine/transmission error menu .....	8 - 45
<b>8.10</b>	<b>Procedure during malfunctions</b> .....	8 - 47
8.10.1	Procedure during engine malfunctions .....	8 - 47
8.10.2	Procedure during transmission malfunctions .....	8 - 48

### Towing the truck crane out of the danger area

Once you have made all the adjustments as described in this section, you can tow the truck crane away from the hazard area.

- Ensure that the tractor-vehicle accelerates only slowly.



#### **Risk of damage to the chassis!**

Starting jerkily or quickly can damage the chassis!

- Remember that the steering will be sluggish.  
If the engine fails, only the emergency steering pump will be available, which supports the steering only from a speed of at least 2 km/h (1.2 mph).



#### **Risk of accidents due to sluggish steering!**

At speeds less than 2 km/h (1.2 mph) the truck crane is barely steerable.

- Tow the truck crane at a **maximum of 7 km/h** (4 mph).
- Ensure that the towing distance does not exceed **100 m** (330 ft).

### Longer towing distances

If a vehicle with automatic transmission is to be towed for a distance **greater than 100 m** (330 ft) you must disconnect the Cardan shaft between the transfer case and transmission.

- If you need to tow the truck crane further than **100 m** (330 ft) contact **Manitowoc Crane Care**.



#### **Risk of accidents and damage when towing the truck crane long distances!**

Tow the truck crane at a maximum speed of 7 km/h (4 mph) and for a maximum distance of **100 m** (330 ft). For longer distances, additional measures must be taken, contact **Manitowoc Crane Care**.

## 8.3.2

### Tow starting

Tow starting is not possible for reasons related to the transmission.

## 8.6

### Tilting/lowering the driver's cab

To tilt the driver's cab (e.g. for maintenance work), the main boom must be raised and the hoisting gear moved.

This assumes that the engine can be started.



If the engine cannot be started, you must use the hydraulic emergency operation to lift the main boom;  p. 14 - 59.

### 8.6.1

#### Prerequisites and information on tilting

Before tilting the driver's cab, the following requirements must be met:

- The truck crane must be level.
- All loose objects must be removed from the driver's cab!
- The main boom is raised to the extent (approx. 1.5 m (4.9 ft)) that the driver's cab will not touch the main boom (nor the hose drum) when tilting!
- Ensure that the hook block is outside the driver's cab slewing range and the windscreen.



#### **Risk of damage to the steering's universal joint!**





The steering wheel may only be moved when the driver's cab is lowered and locked. When moving the steering wheel into other driver's cab positions, the steering's universal joint can be damaged.

Designation	Amperage (A)	Function
F6/1	5	Engine emergency stop switch Tachograph, instrument panel
F6/2	3	Control unit CCM 11 Control unit IOL 31/32/33
F6/3	3	CCS display Reverse camera Radio
F6/4	5	Air intake inhibitor
F6/5	10	Gearbox control
F6/6	5	Engine/transmission diagnostics plug
F6/7	3	Outrigger control panel left/right Inclination transmitter
F6/8	3	Engine electronic control system AdBlue system

Designation	Amperage (A)	Function
F7/1	3	Alternator
F7/2	3	Brake circuits 1 and 2
F7/3	3	Auxiliary heater time switch
F7/4	15	Transmission retarder
F7/5	5	Horn Particulate filter
F7/6	-	Unassigned
F7/7	10	Operating the mirror adjustment Window winder
F7/8	-	Unassigned



## 8.8.6 Malfunctions of the service brake

Malfunction		Cause	Remedy
<b>Lights up while driving or does not go out after the engine is started</b>		The air pressure in one of the two circuits has fallen below 5.5 bar (80 psi)	The vehicle can be driven slowly to the next repair shop
		The air pressure in both circuits has fallen below 5.5 bar (80 psi)	1. Top up the compressed-air supply on the filler connection;  p. 8 - 6
			2. Tow the truck crane with the tow-rod;  p. 8 - 6
<b>Parking brake unable to be released</b>		Supply pressure too low	 <i>Building up supply pressure</i> , p. 5 - 10
<b>The retarder cannot be engaged</b>		Fuse F7/4 blown	Replace blown fuses;  p. 8 - 26



Further information;  *CCS warning/error message*, p. 8 - 41.

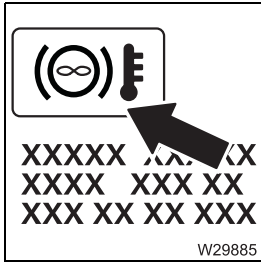

The oil temperature of the retarder is too high.

- Shift to a lower gear – the engine speed increases and the engine braking effect increases.

1 Side panel	➡ p. 9 - 8
2 Sun visor	
3 Current degree of utilisation display <sup>1)</sup>	➡ p. 9 - 139
4 Door unlocking mechanism	➡ p. 9 - 153
5 Lock/unlock windows	➡ p. 9 - 152
6 Air vents	➡ p. 11 - 134
7 Emergency stop switches	➡ p. 9 - 88
8 Windscreen washing system tank <sup>2)</sup>	
9 RCL control unit ( <b>R</b> ated- <b>C</b> apacity- <b>L</b> imiter)	➡ p. 9 - 67
10 Adjusting the front panel	➡ p. 11 - 9
11 CCS control unit	➡ p. 9 - 16
12 Slewing gear freewheel <sup>1)</sup>	
13 Service brake <sup>1)</sup>	
14 Accelerator	
15 Left-hand control panel	➡ p. 9 - 12
16 Right-hand control panel	➡ p. 9 - 13
17 Handle	
18 Crane cab seat with Seat contact switch	➡ p. 11 - 8 ➡ p. 9 - 93
19 Rest	
20 Ignition lock	➡ p. 9 - 90
21 Cigarette lighter (24 volts)	
22 Ashtray	
23 Crane cab, rear	➡ p. 9 - 10

<sup>1)</sup> Additional equipment

<sup>2)</sup> ➡ *Maintenance Manual*



<b>1</b>	<b>CCS display</b>	
	– Overview of the CCS start menu	▣▣▣▣▶ p. 9 - 19
	– Overview of the CCS menu groups	▣▣▣▣▶ p. 9 - 20
<b>2</b>	<b>Jog dial</b>	▣▣▣▣▶ p. 9 - 130
<b>3</b>	<b>Service/diagnosis connection<sup>1)</sup></b>	▣▣▣▣▶ p. 9 - 154
<b>4</b>	<b>Exiting the menu/input mode</b>	▣▣▣▣▶ p. 9 - 130
<b>5</b>	<b>Selector buttons</b>	▣▣▣▣▶ p. 9 - 83
<b>6</b>	<b>no function</b>	
<b>6.1</b>	<b>Operating in the Outrigger menu</b>	▣▣▣▣▶ p. 9 - 95
<b>7</b>	<b>Warning for lifting limit switch shutdown</b>	▣▣▣▣▶ p. 9 - 111
<b>8</b>	<b>Brightness sensor<sup>2)</sup></b>	
<b>9</b>	<b>Input confirmation</b>	▣▣▣▣▶ p. 9 - 83
<b>10</b>	<b>Changing menus</b>	▣▣▣▣▶ p. 9 - 83
<b>11</b>	<b>Switch display</b>	▣▣▣▣▶ p. 9 - 89
<b>12</b>	<b>Slewing gear brake applied/released</b>	▣▣▣▣▶ p. 9 - 115
<b>13</b>	<b>Sensor temperature display</b>	▣▣▣▣▶ p. 9 - 88

<sup>1)</sup> For Service personnel only, not suitable for external devices, e.g. mobile phone

<sup>2)</sup> no function

## Outrigger menu

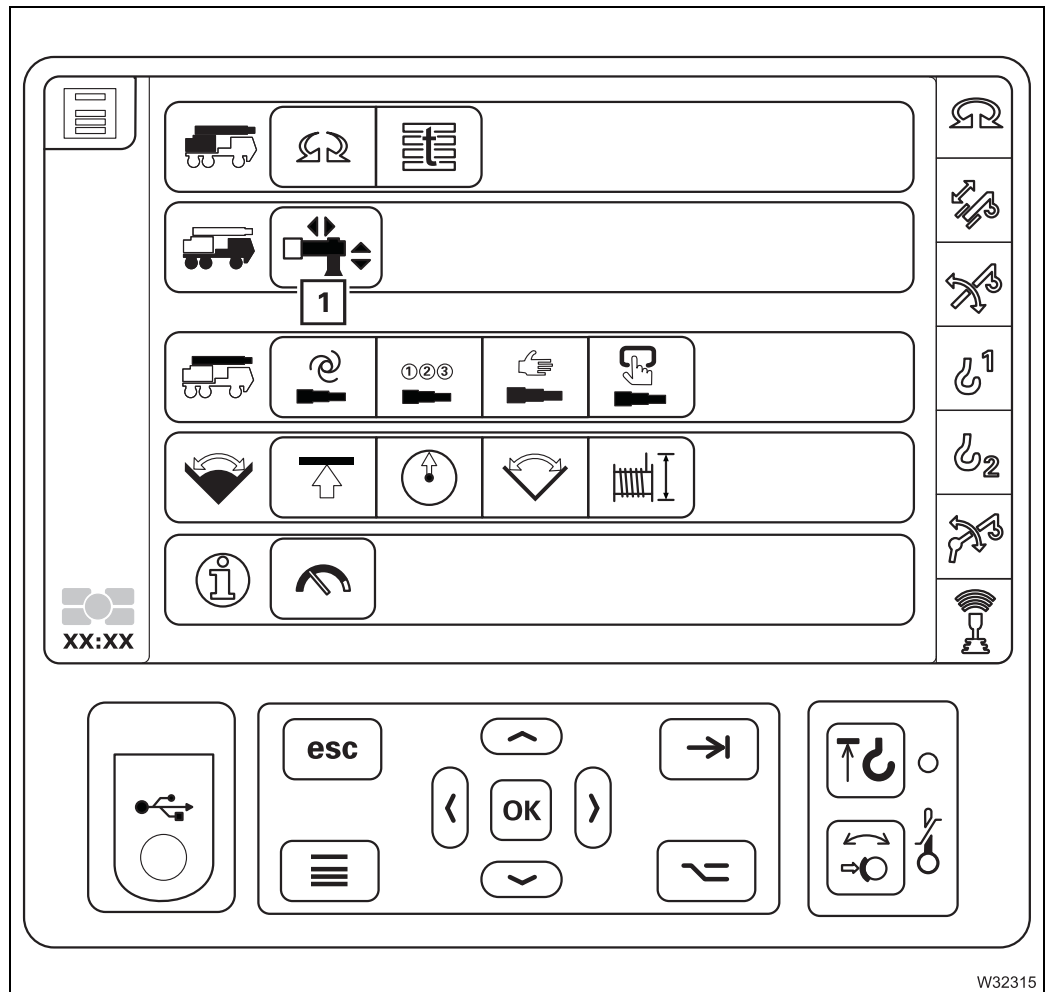

- 1 – Outrigger support beam menu
- Outrigger cylinders menu

- ▶▶▶ p. 9 - 29
- ▶▶▶ p. 9 - 30



**Active working  
range limiter  
menu group**

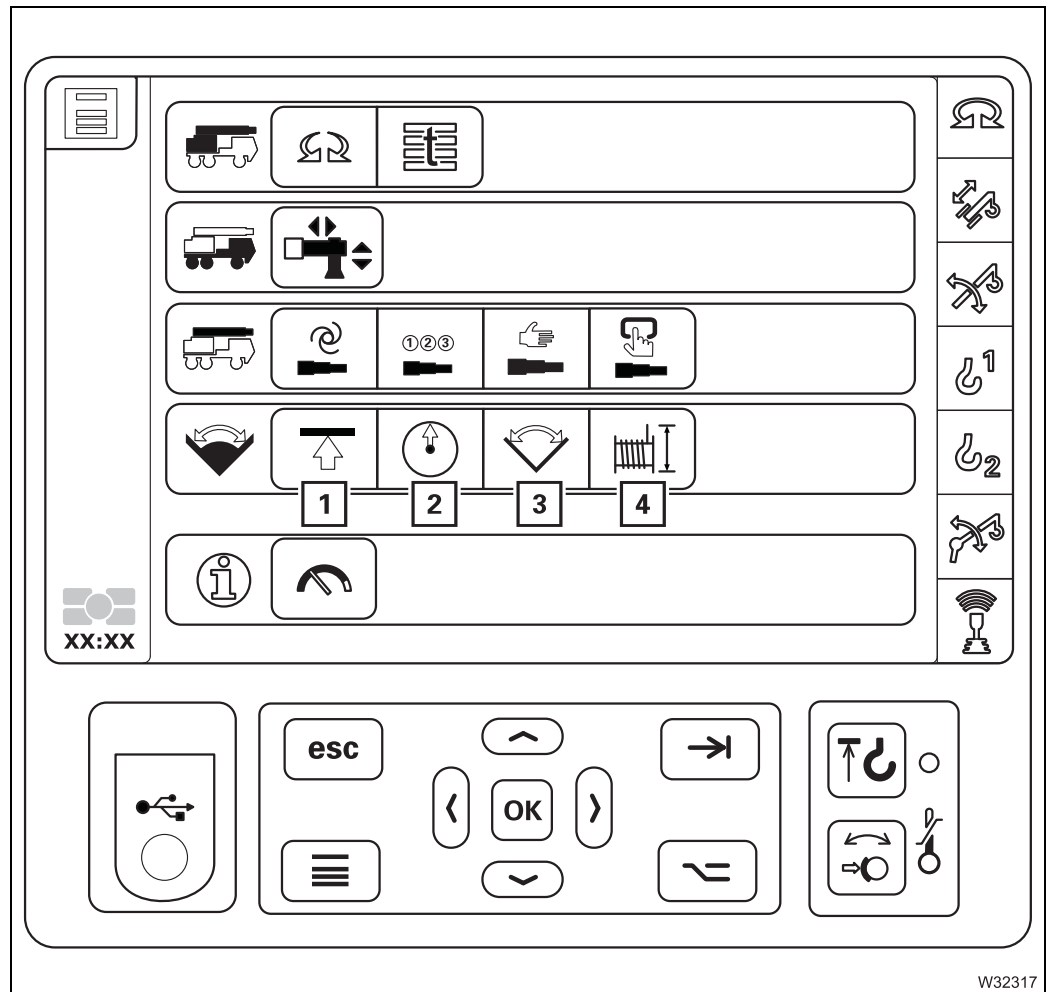

- |  |             |
|--|-------------|
| <b>1</b> Overall height menu               | ➡ p. 9 - 38 |
| <b>2</b> Working radius menu               | ➡ p. 9 - 39 |
| <b>3</b> Slewing angle menu                | ➡ p. 9 - 40 |
| <b>4</b> Hoist rope travel limitation menu | ➡ p. 9 - 41 |



<b>1</b>	Transmission mode <b>RM</b>	▣▣▣▣ p. 9 - 156
<b>2</b>	Transmission mode <b>R</b>	▣▣▣▣ p. 9 - 156
<b>3</b>	Neutral position <b>N</b>	▣▣▣▣ p. 9 - 156
<b>4</b>	Transmission mode <b>D</b>	▣▣▣▣ p. 9 - 156
<b>5</b>	Transmission mode <b>DM</b>	▣▣▣▣ p. 9 - 156
<b>6</b>	Current transmission mode display	
<b>7</b>	Steering lock display	▣▣▣▣ p. 9 - 155
<b>8</b>	Current wheel position display	▣▣▣▣ p. 9 - 160
<b>9</b>	Steering locking status display	▣▣▣▣ p. 9 - 161
<b>10</b>	– Transverse differential locks display	▣▣▣▣ p. 9 - 157
	– Transverse differential locks on/off	▣▣▣▣ p. 9 - 157
<b>11</b>	– Longitudinal differential lock display	▣▣▣▣ p. 9 - 158
	– Longitudinal differential lock on/off	▣▣▣▣ p. 9 - 157
<b>12</b>	Supply pressure brake circuits 1 and 2 display	▣▣▣▣ p. 9 - 158
<b>13</b>	Parking brake indicator lamp	▣▣▣▣ p. 9 - 159
<b>14</b>	Crane hydraulic system on/off	▣▣▣▣ p. 9 - 155
<b>15</b>	Steering mode switched on indicator	
<b>16</b>	Normal steering mode / on-road driving on	▣▣▣▣ p. 9 - 161
<b>17</b>	Separate steering, manual on	▣▣▣▣ p. 9 - 161
<b>18</b>	Automatic separate steering driving around curves on	▣▣▣▣ p. 9 - 162
<b>19</b>	Automatic separate steering for crab travel mode on	▣▣▣▣ p. 9 - 162



**Menu for setting the display brightness and date/time**

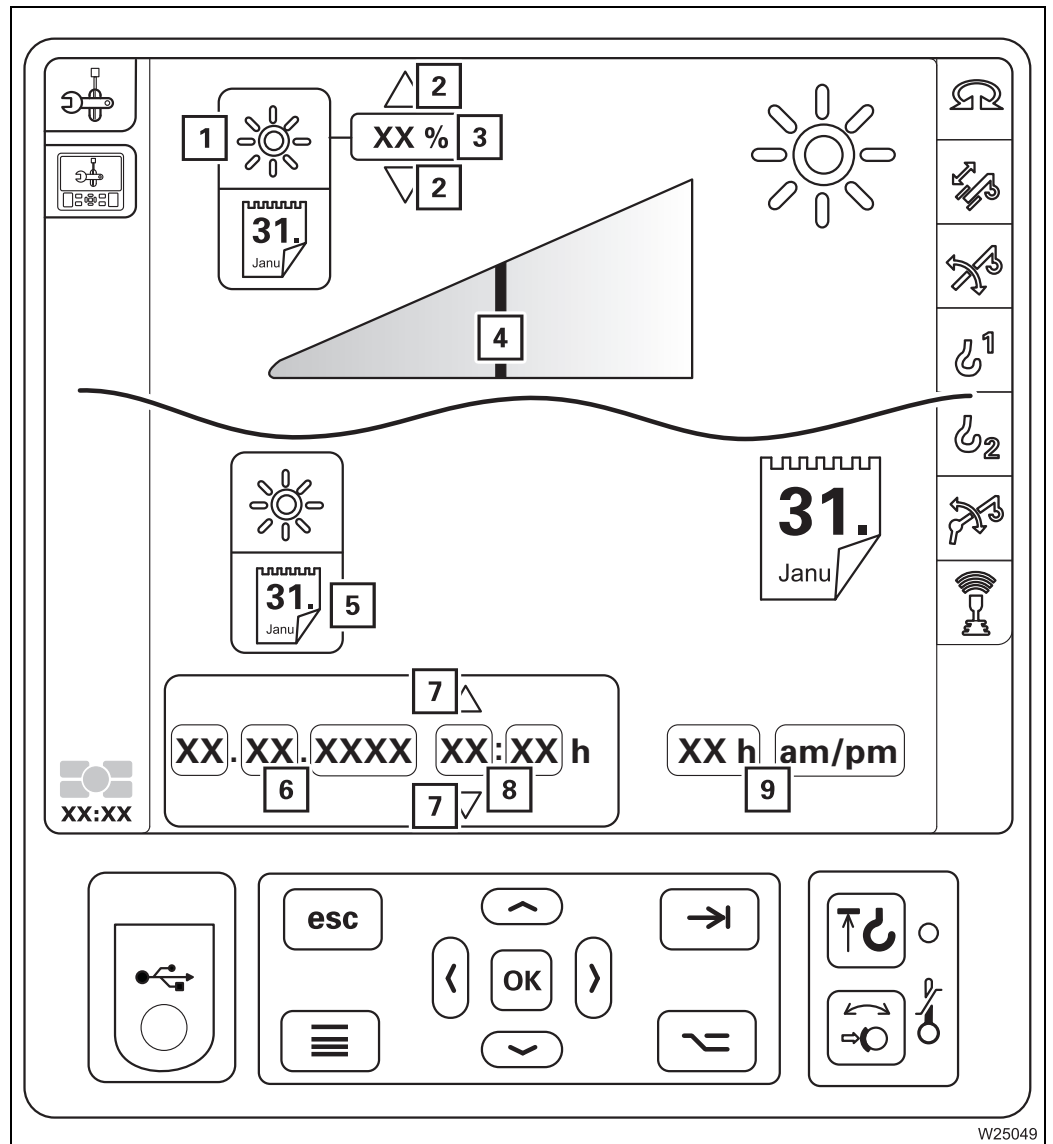

W25049

- |          |  |       |            |
|----------|--|-------|------------|
| <b>1</b> | Selection setting the display brightness | ▣▣▣▣▶ | p. 10 - 7  |
| <b>2</b> | Increasing/reducing the value            | ▣▣▣▣▶ | p. 10 - 7  |
| <b>3</b> | Display in percentage                    | ▣▣▣▣▶ | p. 10 - 7  |
| <b>4</b> | Display                                  | ▣▣▣▣▶ | p. 10 - 7  |
| <b>5</b> | Selection setting the time/date          | ▣▣▣▣▶ | p. 11 - 50 |
| <b>6</b> | Setting the date                         | ▣▣▣▣▶ | p. 11 - 50 |
| <b>7</b> | Increasing/reducing the value            | ▣▣▣▣▶ | p. 11 - 50 |
| <b>8</b> | Setting the time                         | ▣▣▣▣▶ | p. 11 - 50 |
| <b>9</b> | Switching the display type               | ▣▣▣▣▶ | p. 11 - 50 |



**9.1.8**

**RCL control unit**

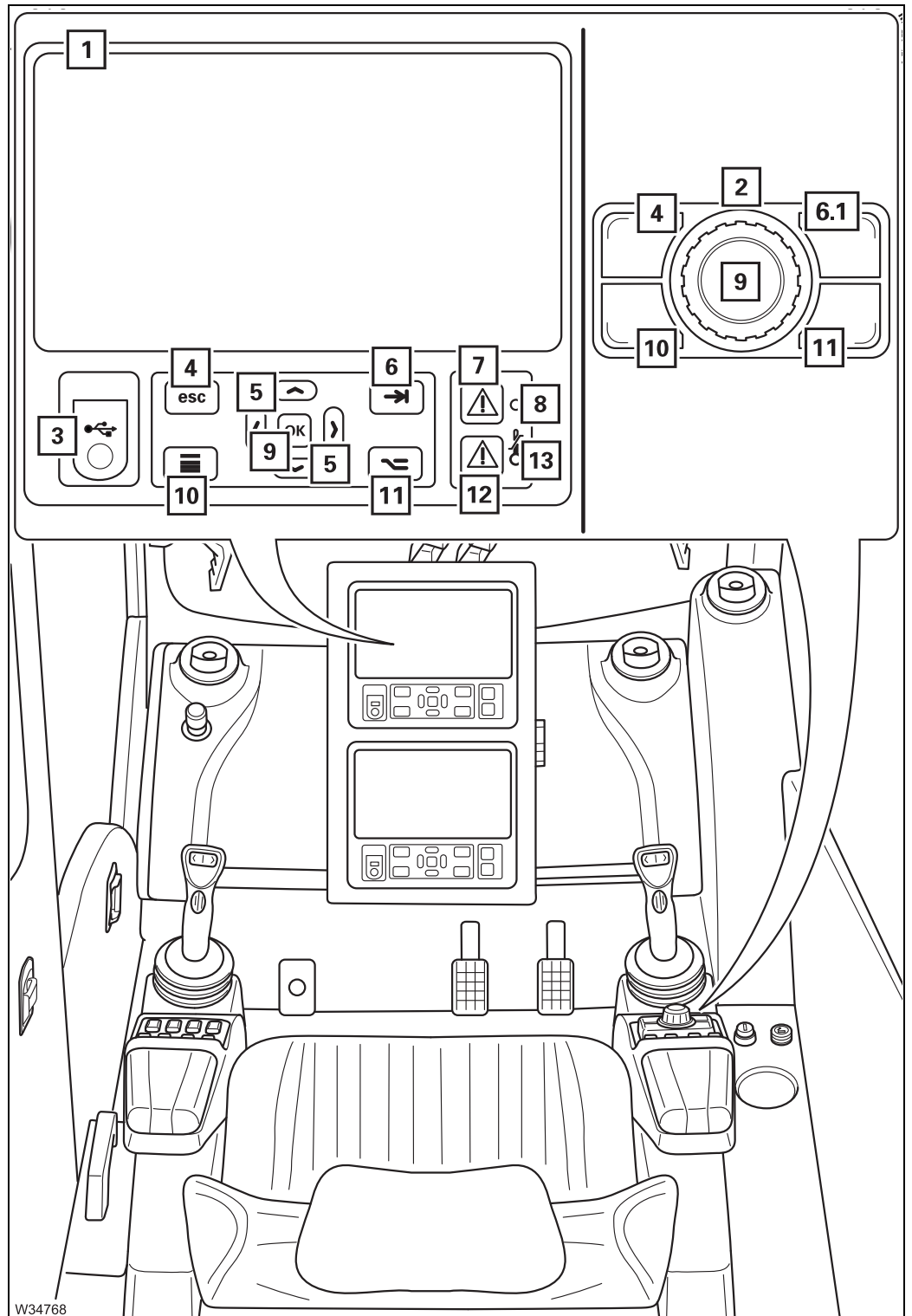

03.07.2017



CLICK HERE TO **DOWNLOAD** THE COMPLETE MANUAL

- Thank you very much for reading the preview of the manual.
- You can download the complete manual from: [www.heydownloads.com](http://www.heydownloads.com) by clicking the link below



- Please note: If there is no response to CLICKING the link, please download this PDF first and then click on it.

CLICK HERE TO **DOWNLOAD** THE COMPLETE MANUAL



**Opposite** means: on the side of the carrier opposite to the operator when looking at the control unit.

**Left and right** mean: to the left or the right of the control unit.

## Outrigger button

- |           |   |                 |
|-----------|---|-----------------|
| <b>1</b>  | Operating the left-hand outrigger                             | ▣▣▣▣ p. 9 - 99  |
| <b>2</b>  | Operate left outrigger, opposite                              | ▣▣▣▣ p. 9 - 99  |
| <b>3</b>  | Operating the right-hand outrigger                            | ▣▣▣▣ p. 9 - 99  |
| <b>4</b>  | Operate right outrigger, opposite                             | ▣▣▣▣ p. 9 - 99  |
| <b>5</b>  | Inclination indicator   | ▣▣▣▣ p. 9 - 78  |
|           | Raise axle display  | ▣▣▣▣ p. 9 - 79  |
|           | Outrigger pressure display                                    | ▣▣▣▣ p. 9 - 78  |
| <b>6</b>  | Additional function F1 on/Position lights for indicator lamps | ▣▣▣▣ p. 9 - 100 |
| <b>7</b>  | Additional function F2 Select axle pairs                      | ▣▣▣▣ p. 9 - 102 |
| <b>8</b>  | Additional function F3 Select axle pairs                      | ▣▣▣▣ p. 9 - 102 |
| <b>9</b>  | Additional function F4 Menu selection                         | ▣▣▣▣ p. 9 - 102 |
|           | – Outrigger   |                 |
|           | or  |                 |
|           | – Raise axle  |                 |
| <b>10</b> | In the Outrigger menu   | ▣▣▣▣ p. 9 - 100 |
|           | – Retract all outrigger cylinders                             |                 |
|           | In the Raise axle menu  |                 |
|           | – Raise the axles   | ▣▣▣▣ p. 9 - 102 |
| <b>11</b> | Pre-select high-speed mode                                    | ▣▣▣▣ p. 9 - 99  |
| <b>12</b> | Switching over the measuring range                            | ▣▣▣▣ p. 9 - 101 |
| <b>13</b> | Engine START  |                 |
| <b>14</b> | In the Outrigger menu   | ▣▣▣▣ p. 9 - 100 |
|           | – Extend all outrigger cylinders                              |                 |
|           | In the Raise axle menu  |                 |
|           | – Lower the axles   | ▣▣▣▣ p. 9 - 102 |
| <b>15</b> | – Pre-select normal mode                                      | ▣▣▣▣ p. 9 - 99  |
|           | – Automatic alignment   | ▣▣▣▣ p. 9 - 100 |
|           | (as additional function F1)                                   |                 |
| <b>16</b> | Horn  |                 |
| <b>17</b> | Engine STOP   |                 |



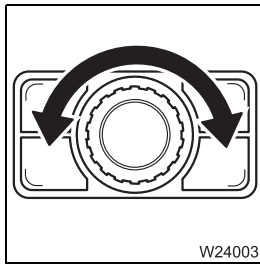

### Enter the values with jog dial

The input mode is active.

- **To the right:** Increases the value
- **To the left:** Decreases the value

Slowly turning changes the value gradually

Holding pressed and turning results in a quick value change

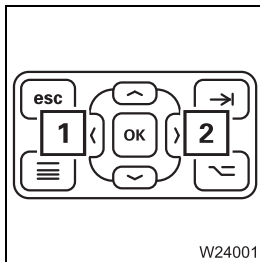

### Enter values on the control panel CCS

The input mode is active.

- **Arrow pointing to the right:** Increases the value
- **Arrow pointing to the left:** Decreases the value

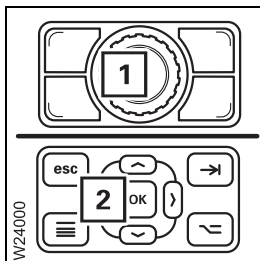

### Input confirmation

An input can be confirmed with button (1) or (2)

- **Press the button once:** A newly entered value is confirmed

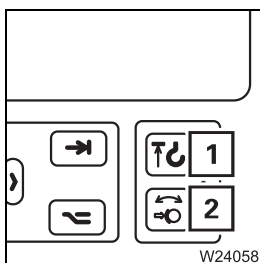

### Other

- 1 Lifting limit switch warning; p. 9 - 114
- 2 Slewing gear brake indicator lamp; p. 9 - 114

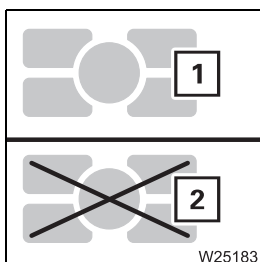

- 1 Display active
  - 2 Display inactive
- Switch display*, p. 9 - 89





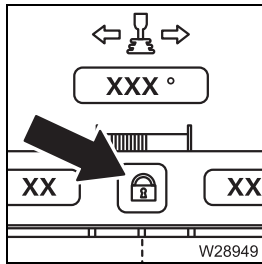

### Automatic mode rigging

- **Display**      **Yellow:** Recognition that the counterweight is rigged
- Flashing:** Automatic mode on
- Grey**      Automatic mode cancelled or no recognition that the counterweight is rigged

The superstructure is within the rigging range, the slewing gear is switched on and the lifting cylinders are retracted

- **Switch on:**      Select symbol and confirm – symbol flashes yellow
- **To execute:**      Move control lever for slewing gear, automatically:
  - Slewing in position *Move lifting cylinders*
  - Extend lifting cylinders,

Move the control lever for slewing gear in indicated direction, automatically:

  - Slewing in position *Lift/lower counterweight*,
  - Lift counterweight,
  - Pre-tension counterweight.

Automatic mode ends – symbol yellow

➡ p. 12 - 94

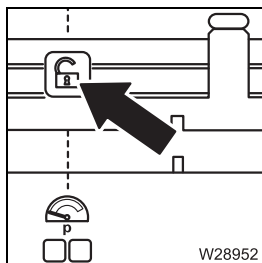

### Automatic mode unrigging

- **Display**      **Yellow:** Recognition that the counterweight is unrigged
- Flashing:** Automatic mode on
- Grey**      Automatic mode cancelled or no recognition that the counterweight is unrigged

The superstructure is within the rigging range and the slewing gear is switched on

- **Switch on:**      Select symbol and confirm – symbol flashes yellow
- **To execute:**      Move control lever for slewing gear, automatically:
  - Slewing in position *Lift/lower counterweight,,*
  - Lower the counterweight,

Move the control lever for slewing gear in indicated direction, automatically:

  - Slewing in position *Move lifting cylinders*,
  - Retract the lifting cylinders,

Automatic mode ends – symbol yellow

➡ p. 12 - 96



## CCS display

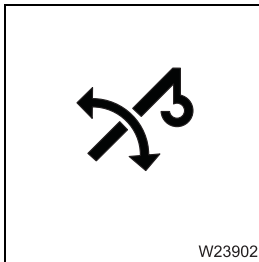

### Power units display

- **Green:** Derricking gear on
- **Red:** Derricking gear off

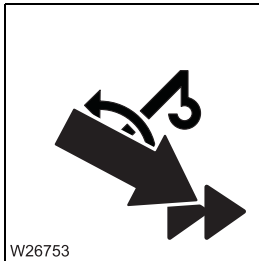

### High-speed mode inspection derricking gear

- **On:** High-speed mode on
- **Off:** High-speed mode off

➡ p. 11 - 95

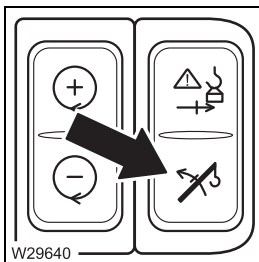

### Raise button, shutdown bypassed

- **On:** Shutdown bypassed
- **Off:** Shutdown not bypassed

➡ p. 11 - 47

## 9.2.19

### Superstructure lock/house lock menu

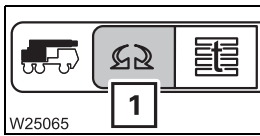

– **To open:** Select symbol (1) and confirm

#### Superstructure lock

▮▮▮▮ Locking/unlocking the superstructure, p. 11 - 15.

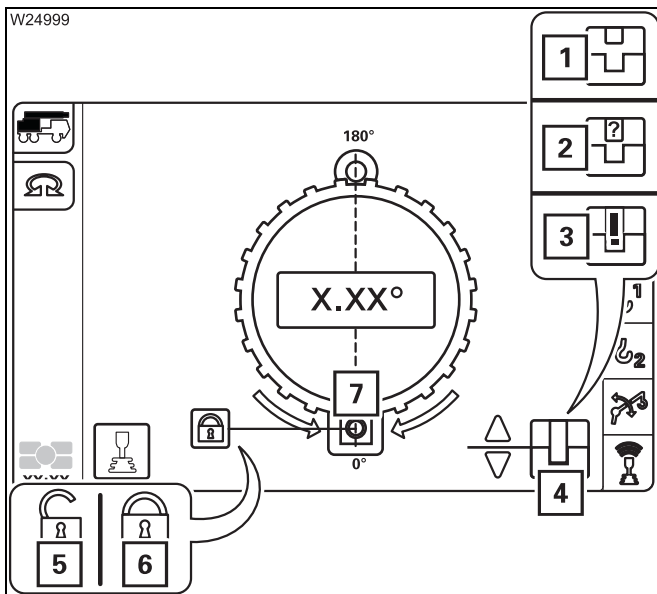

#### Locking status displays

The current position of the locking pin is shown by different symbols:

- 1 and 7** red – unlocked
- 2 and 7** yellow – intermediate position
- 3 and 7** violet – error
- 4 and 7** green – locked

and

- 5** Unlocked
- 6** Locked

▮▮▮▮ p. 11 - 16

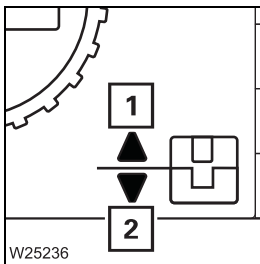

#### Locking/unlocking the turntable

The superstructure is in the 0° or 180° position.

**To unlock:** Symbol (1) – locking pins retract

**To lock:** Symbol (2) – locking pins extend

▮▮▮▮ p. 11 - 16

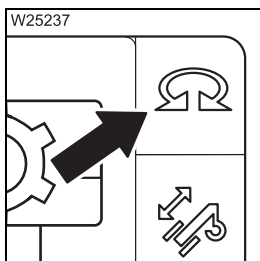

#### Slewing gear display

– **Green:** Slewing gear switched on

– **Red:** Slewing gear switched off

▮▮▮▮ p. 11 - 17



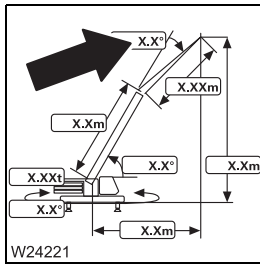

### Display of the lattice extension angle

The hydraulic lattice extension is connected.

- **Display:** Current angle between lattice extension and main boom in degrees (°) – for displayed RCL code

▣▣▣▣ p. 11 - 38

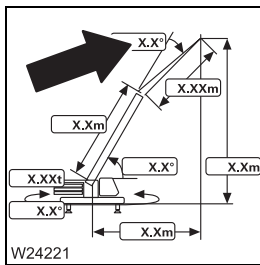

### Lattice extension angle display

The mechanical lattice extension must be connected.

- **Display:** Lattice extension angle.  
Current angle between lattice extension and main boom in degrees (°) – for displayed RCL code

▣▣▣▣ p. 11 - 38

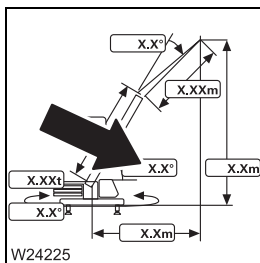

### Current main boom angle display

- **Display:** Current angle between main boom and horizontal position in degrees (°)

▣▣▣▣ p. 11 - 37

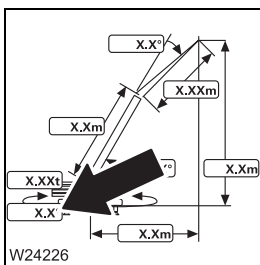

### Current slewing angle display

- 0°: Position 0° to the rear
- 180°: Position 180° to the front
- + 0.1 bis +180.0°: Turned to the right from 0°
- 0.1 to -179.9°: Turned to the left from 0°

▣▣▣▣ p. 11 - 38





### 9.3.3 Final drive

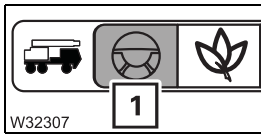

#### Driving mode menu

**To open:** Select symbol (1) and confirm – menu is opened

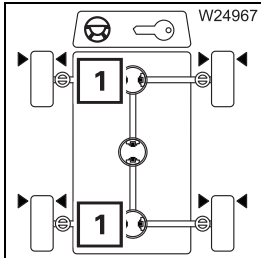

#### Transverse differential locks on/off

- **Switching on:** Select symbol (1) and confirm – symbol is **red**
- **To switch off:** Select symbol (1) and confirm – symbol is **green**

When a symbol (1) is selected **both** transverse differential locks are switched on or off.

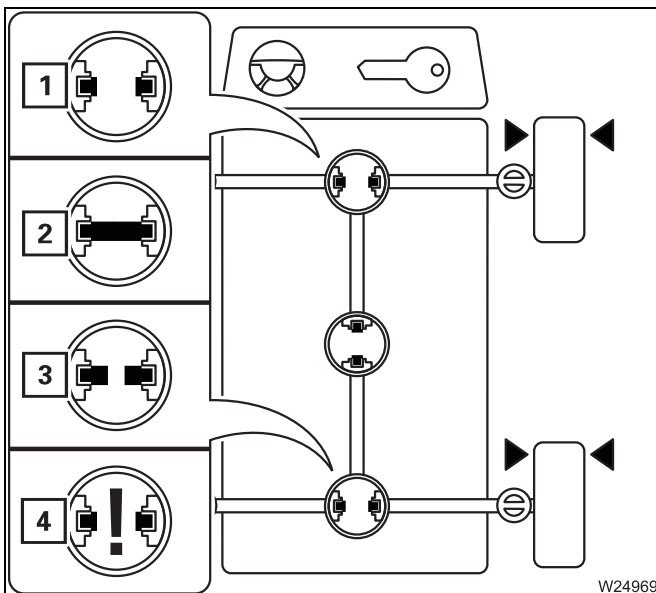

#### Transverse differential locks display

The current status is shown using different symbols:

- 1 green** – locks off
- 2 red** – locks on
- 3 yellow** – intermediate position
- 4 violet** – error

▶ p. 13 - 25

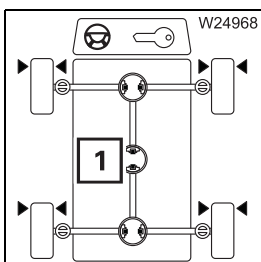

#### Longitudinal differential lock on/off

- **Switching on:** Select symbol (1) and confirm – symbol is **red**
- **To switch off:** Select symbol (1) and confirm – symbol is **green**





# 10

## Starting/switching off the engine – for crane operation

You must start the engine from the crane cab for crane operation. If the engine has been started from the carrier, then you must shut it down in the carrier and switch off the ignition before crane operation.

All the power units required for crane operation are only released when you start the engine from the crane cab.

The procedure depends on whether you:

- start the (cold) engine for the first time in the day,
- start the engine from the crane cab;  p. 10 - 3,
- start the engine with the hand-held control;  p. 10 - 11.

### 10.1

### When starting the engine for the first time in the day





#### Risk of crushing due to turning wheels!

When you start the engine, no persons may be within the steering range of the 4th and 5th axle lines. These axle lines are steered each time the engine is started, sometimes with a 5-second delay, in order to test the steering system.

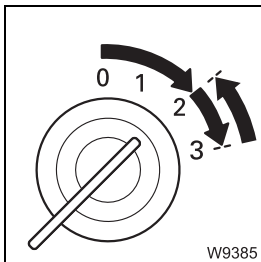
The first start of the day should always be made from the **driver's cab**, as all the displays for monitoring the engine can only be accessed there.



- Carry out all the required tasks and checks for starting the engine;  *CHECKLIST: Starting the engine*, p. 4 - 1.
- Start the engine from the driver's cab and perform all the necessary checks;  *Inspections after starting the engine*, p. 4 - 16.

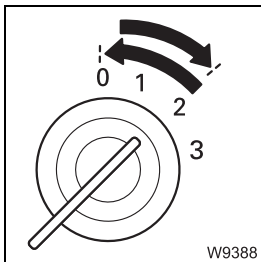

- Switch the engine off and switch off the ignition.



## 10.3

### Starting the engine – with the hand-held control



You can only start the engine when bridging plugs are inserted in all sockets that are not required; p. 9 - 148.



#### **Risk of crushing due to turning wheels!**

When you start the engine, no persons may be within the steering range of the 4th and 5th axle lines. These axle lines are steered each time the engine is started, sometimes with a 5-second delay, in order to test the steering system.

All checks required before starting the engine must be carried out; p. 4 - 1.

You can also start the engine if the ignition in the driver's cab or crane cab is switched on.

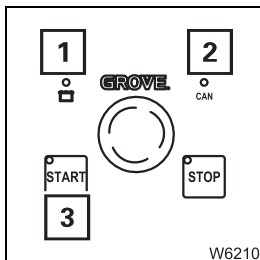

- Wait until the lamps (1) and (2) illuminate.
- If the lamp (2) does not illuminate or flash after about 20 seconds, there is a malfunction; p. 8 - 33.
- Press the button (3) once – the engine will start.



If the hand-held control is connected to the superstructure, you cannot drive the power units from the crane cab.

## 11.1.2 Checking the condition of the truck crane

### Fuel tank auxiliary heater

Use the same fuel as for the engine or use EL heating oil for refuelling.

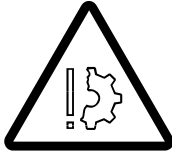

#### **Danger of fire due to flammable gases!**

Turn off the engine and heating systems before refuelling.

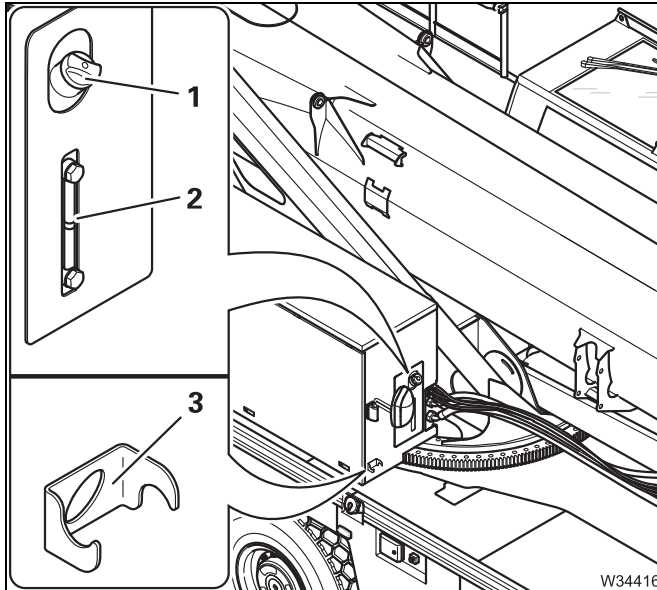

Insert the fuel nozzle in the clamp (3).

- The display (2) shows the fuel level in the tank (1).
- Refuel in due time and seal the tank (1) with the cap.

### Visual inspection

Walk around the truck crane and look out in particular for leaking oil, fuel or coolant.



#### **Danger if the crane cannot be unrigged!**

If oil is lost, you may no longer be able to move the crane. Not even in emergency mode.



#### **Risk of environmental damage due to leaking consumables!**

Immediately repair or have repaired oil, fuel and coolant leakages. This prevents oil or fuel from seeping into the ground or polluting waters.



## 11.1.7 Locking/unlocking the superstructure

To lock, a pin can extend on the turntable and engage in two locking points on the carrier.

**Locking points** The locking points are at 0° and at 180 °C.

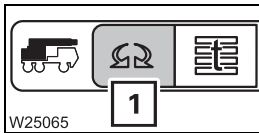

- Open the *Superstructure lock* (1) menu.

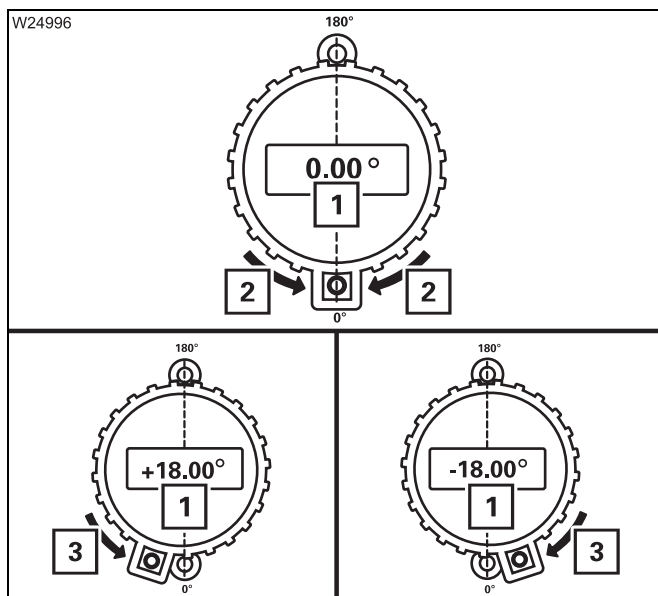

The display (1) shows the current superstructure position.

- Slew to the locking point at **0°** or **180°**.

The display (1) shows positive and negative values. For an overview;  p. 11 - 100.

At the locking point, both arrows (2) are shown.

In the range of  $\pm 20^\circ$  around the locking point, an arrow (3) indicates the slewing direction that leads to the locking point.



## 11.2.2 Enter rigging mode

For a complete rigging mode input, you must enter, confirm and accept the rigging mode and the reeving.

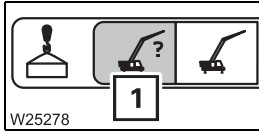

- Open the *Enter rigging mode* menu (1) if necessary.

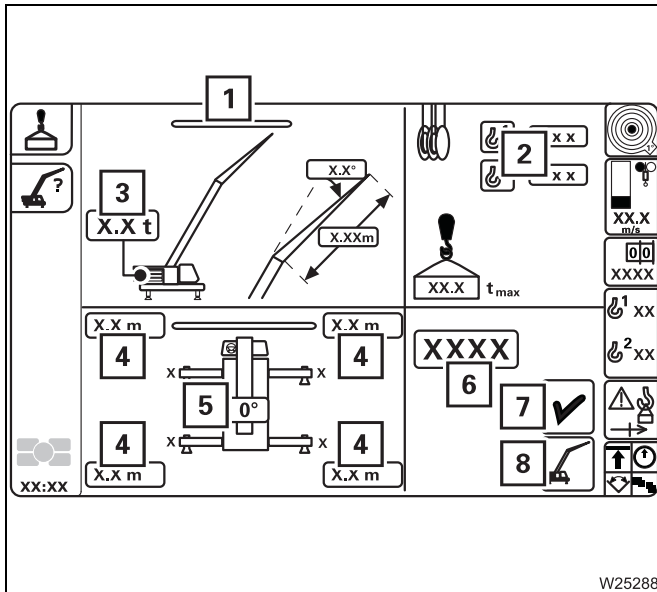

There are two ways of entering the current rigging mode.

- **Either** enter the individual components (1) to (5) one after the other.
  - **Or** enter the RCL code (6) and the reeving (2).
- The newly entered rigging mode must then be confirmed
- confirm with (7)
  - and
  - accept with (8).

The following section describes the input procedure based on the individual components. If you want to enter the rigging mode based on the RCL code;   
 ■■■▶ *Entering the RCL code*, p. 11 - 31.



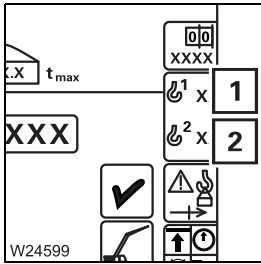

### Hoists display

The symbol for the hoist with which the load is to be lifted must be shown in **green**:

Symbol (1): must be shown in **green** if the load is to be raised with the main hoist.

Symbol (2): must be shown in **green** if the load is to be raised with the auxiliary hoist.

- Switch over the display if necessary;  *Example of switching over the display, p. 11 - 36.*

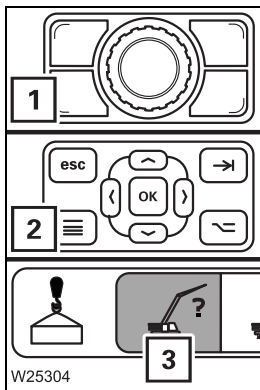

- If you need to correct values, press the button (1) or (2) and open the *Enter rigging mode* menu (3).

You can start working with the crane if the current rigging mode of the truck crane is displayed.



**To raise the boom** You can release the raise boom function for derricking again within the permitted working range.



This function is only active if the current degree of utilisation lies above 100% and the crane movements are switched off.

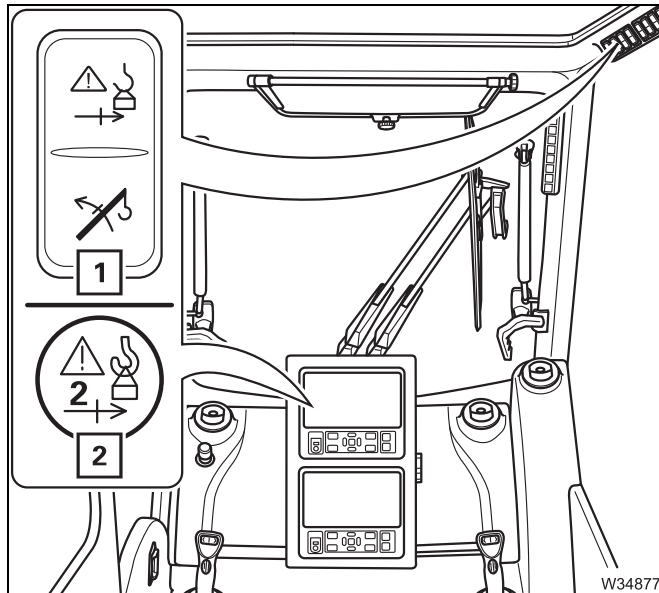

### Raise main boom

- Press the button (1) once – the information message (2) is displayed.
  - Raising is enabled.
  - The speed will then be reduced to 50%.
- Raise the main boom until the degree of utilisation is less than 100%.
  - The crane movements will then be enabled again.
  - The button (1) has no function.



The raising of the main boom will be shut down if the main boom angle is too great. Then all you can do is set the load down.

### Switch off function

- For degree of utilisation above 100%

The function will be switched off if you:

- press button (1) again, or
- switch off the ignition.

- For degree of utilisation below 100%

The function is switched off automatically.



### 11.3.3

## Main hoist

You can reeve the hoist rope of the main hoist on the main boom or on the lattice extension.



#### **Risk of accidents from accidentally operating a hoist!**

Always switch off the hoist that is not in use!

Never operate the hoist if the hook block is unreeled and the hoist rope is completely wound onto the drum.

- The rope will slacken in the course of the *Lower* movement. Rope loops will form, which can cause the load to slip and damage the hoist rope.
- The switch-off point of the lowering limit switch shifts in the course of the *Raise* movement. The lowering limit switch will lose its function as a safety device.



#### **Risk of accidents when raising loads at an angle!**

Loads can cause the main boom to bend, resulting in the hoist rope no longer being aligned in a vertical position. Compensate for the bend by lowering the boom so that the load will be lifted vertically. In this way, you can prevent the load from dragging and helpers from being injured.

Inform all helpers about this issue.



#### **Danger due to slack rope!**

Only use hook blocks and lifting gear of the minimum weight prescribed in the *Lifting capacity table*, depending on the reeving and boom length. This prevents slack rope developing at large heights when lifting without a load. This can result in the load slipping during subsequent lifting procedures.

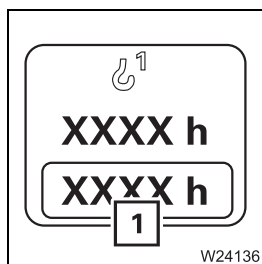

You can display the operating hours (1) of the hoist;  p. 11 - 114.



## Lowering limit switch

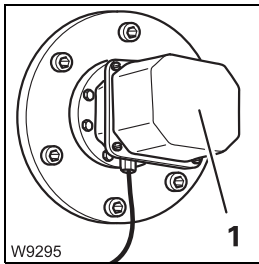

The lowering limit switch (1) prevents the hoist rope from being reeled completely off the drum.

The lowering limit switch works only if the switch-off point is set correctly (e.g. after changing a hoist rope);  *Maintenance Manual*.



### **Risk of accidents due to incorrect setting or intended triggering!**

Prior to operating the crane, ensure that the lowering limit switch is set correctly and always complete the lowering operation before the lowering limit switch is triggered.

This prevents the hoist rope from becoming damaged due to complete unreeling or switching off at high speeds, and the load being dropped as a result.



### **Risk of accidents from incorrect setting of the lowering limit switch!**

Always re-adjust the lowering limit switch if you unreel hoist rope from the stationary rope drum. The lowering limit switch does not record the number of these winds.

This prevents the lowering limit switch from switching off too late or not switching off at all, the hoist rope from being damaged and the from load being dropped.

**Fixed length,  
intermediate  
length, telescoping  
length**

There are lifting capacity tables for main boom fixed lengths, main boom intermediate lengths and main boom telescoping lengths. The lengths are automatically detected by the RCL, and the corresponding lifting capacities according to the *Lifting capacity table* are enabled and displayed automatically.

**Main boom fixed length**

Main boom fixed lengths have the greatest lifting capacities. A main boom fixed length is reached if:

- All telescopic sections are locked to a fixed length
- All telescopic sections are set down.

**Main boom intermediate length**

A main boom intermediate length is reached if not all telescopic sections are locked to fixed lengths.

Extend the main boom to the required length before hoisting the load!  
You cannot telescope the boom with the specified lifting capacities for main boom intermediate lengths.

**Main boom telescoping length**

The main boom is at a telescoping length if it is extended to an intermediate length and may be telescoped with the current load. The size of the load that can be telescoped depends on the angle of inclination and on the degree of lubrication of the main boom.



### Extending/ retracting the telescoping cylinder

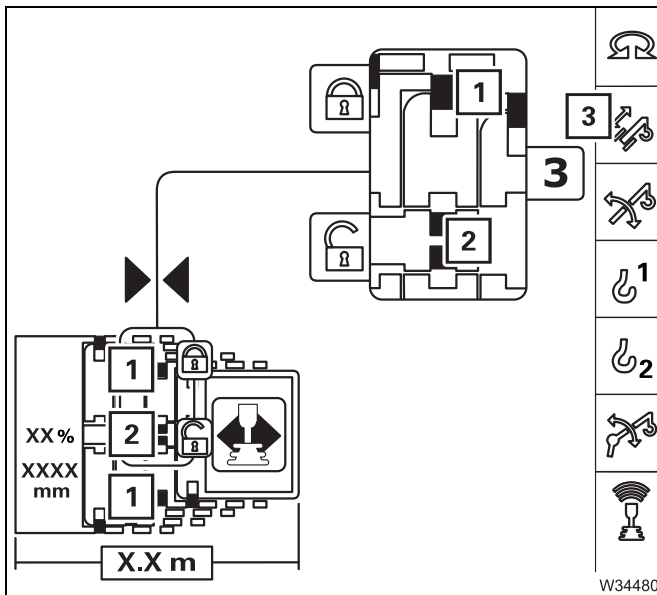

#### Prerequisites

- Telescoping mechanism on – symbol (3) **green**
- Telescopic section locked – symbol (1) **green**
- Telescoping cylinder unlocked – symbol (2) **red**

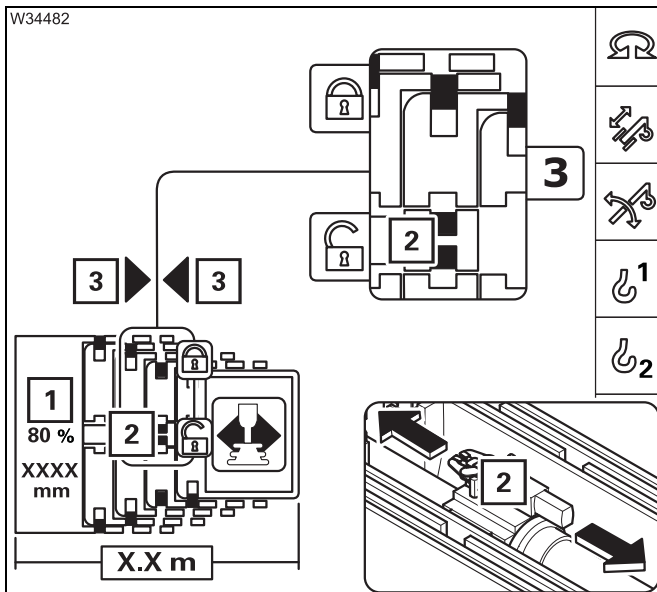

#### Extending/retracting

- Move the control lever in the corresponding telescoping direction:
  - **Extend:** Extending
  - **Retract:** Retracting

The telescoping cylinder (2) extends/retracts.

The display (1) shows the currently extended length, e.g. 80%.

Near a locking point, the symbols (3) show:

- the direction of travel to the locking point:
  - 1 Extending
  - 2 Retracting
  - 3 At the locking point

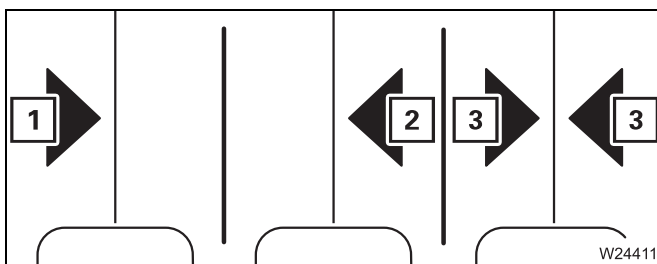

## 11.3.8

### High-speed mode



The slewing gear cannot be operated at high speed.



You can switch on the high-speed mode for a higher speed.

#### **Risk of accidents due to the suddenly accelerating movement!**

Reduce the engine speed before starting high-speed mode.

This will prevent movements from becoming excessively accelerated, which may result in the truck crane starting to sway and overturning.

#### **Derricking gear telescoping mechanism**

High-speed mode is always switched on and off for the derricking gear and the telescoping mechanism at the same time.

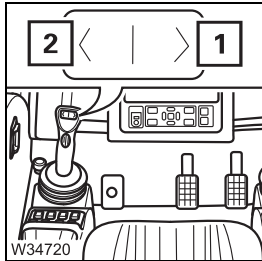

#### **To switch on briefly**

- Press the button at the right on – for (1).  
High-speed mode will be active until you release the button.

#### **Continuous operation**

- Press the button at the left on – for (2).  
High-speed mode will be enabled until you press the button again.

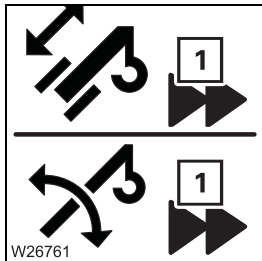

The symbol (1) indicates the current status:

- **On:** High-speed mode switched on
- **Off:** High-speed mode switched off



During lowering of the boom, high-speed mode only supports the start-up of the derricking procedure from steep boom positions; it does not increase the derricking speed.

High-speed mode is disabled for raising when performing operations with the lattice extension.

#### **Hoists**

High-speed mode is always switched on and off simultaneously for the main hoist and the auxiliary hoist.



## 11.4.4 Limiting the power unit speeds

You can enter what percentage of the maximum speed should be enabled for each power unit.

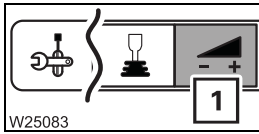

- Select and confirm the symbol (1).

The *Power unit speeds* menu opens.

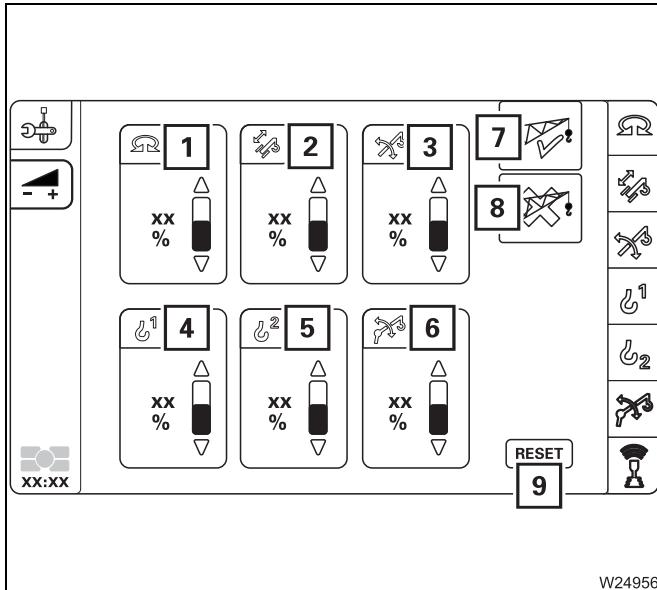

The values below the symbols (1) to (6) indicate the currently set power unit speeds.

The values for the slewing gear (1) and derricking gear (3) only apply if they are lower than the automatically limited values. The automatically limited values are not displayed.

The symbol (5) is only active when the auxiliary hoist is connected.

With the preselection symbol for:

- 7 Operation **with** the lattice extension
- 8 Operation **without** the lattice extension

Symbol (9) resets all values without prior selection.

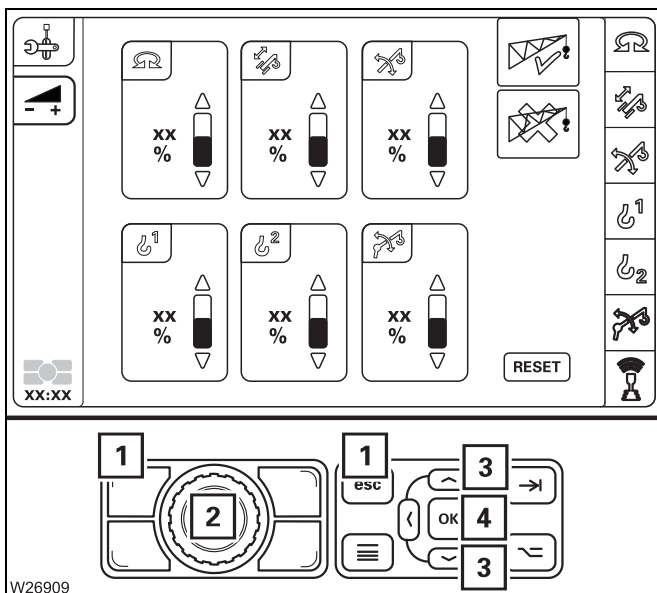

### Changing values

- Select and confirm the symbol for the relevant power unit – symbol **red**.
- Change the value using switch (2) or the buttons (3).

To cancel the input – press button (1) once.

- Confirm the changed values – press switch (2) or button (4) once. The changed values for the power unit are applied.

Blank page

## Working radius

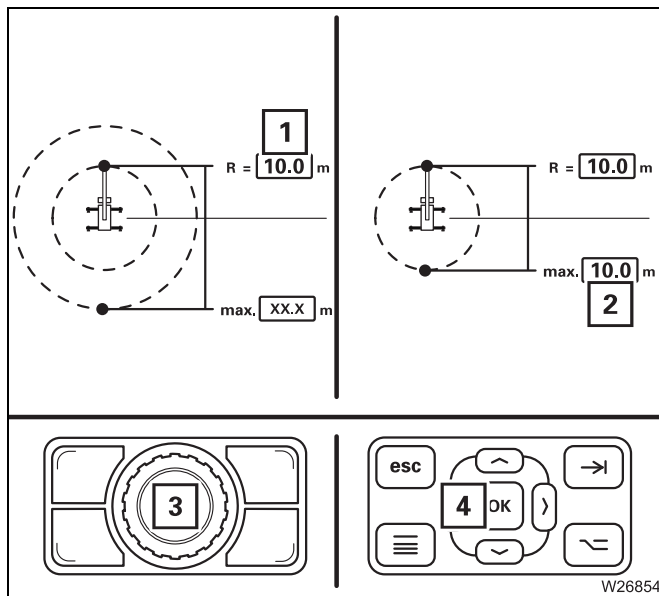

- Move the main boom head to just before the shutdown point without a load, e.g. up to 10.0 m – value (1).
- Press the button (3) or (4) once.
  - The current value (1) will be accepted as the limit value (2).

Switch on monitoring; p. 11 - 129

## Slewing angle

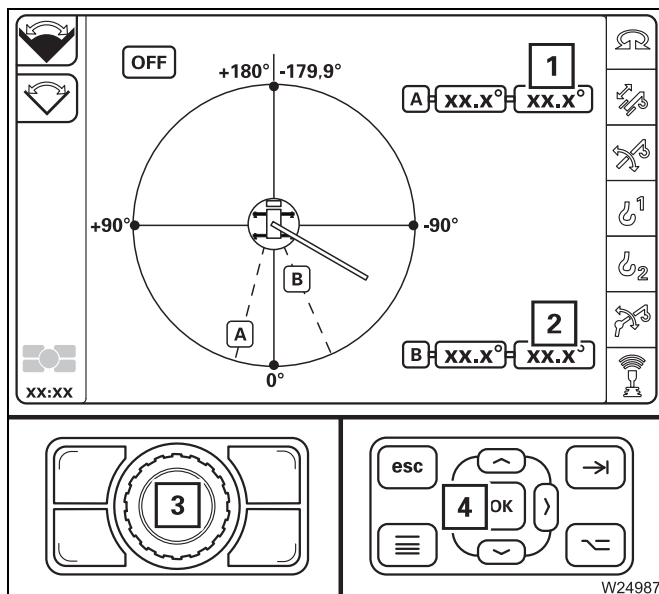

### Display of the slewing angles

- The slewing angle **A** limits slewing to the right.
- The slewing angle **B** limits slewing to the left.

The permissible slewing range is the angle from **A** anticlockwise to **B**. In the illustration approx. 270° – arrow (1).

- Press the button (3) or (4) once.
  - The current value (1) will be accepted as the limit value (2).

Switch on monitoring; p. 11 - 129



## 11.7.2 Air-conditioning system

You can use the air-conditioning system to cool and dry the air in the crane cab.

### Information

Do not cool the air in the crane cab too much. The difference between the outside temperature and the inside temperature should be at the most 10 °C to 14 °C (50 °F to 57.2 °F) . If the cooling is too severe, you may frequently feel physically uncomfortable, albeit mostly only after you leave the cool environment.

Avoid having cold air blowing directly on to your body.

When using recirculated air, you should switch over to fresh air mode to ensure a fresh supply of oxygen at the same time. Adjust the cooling output to your actual needs:

If the truck crane has been exposed to strong sunlight for a long period of time, for example, the air-conditioning system should initially be operated at the highest blower level with the engine running.

The door or at least the windows should be left open for a short while to thoroughly air the cab.

If the air-conditioning system is operated continuously, close the windows and doors to ensure sufficient cooling.

Once the inside temperature has reached the desired temperature, set the fan to a lower level.

### Switching on/off

- Start the engine. The air-conditioning operates only when the engine is running.

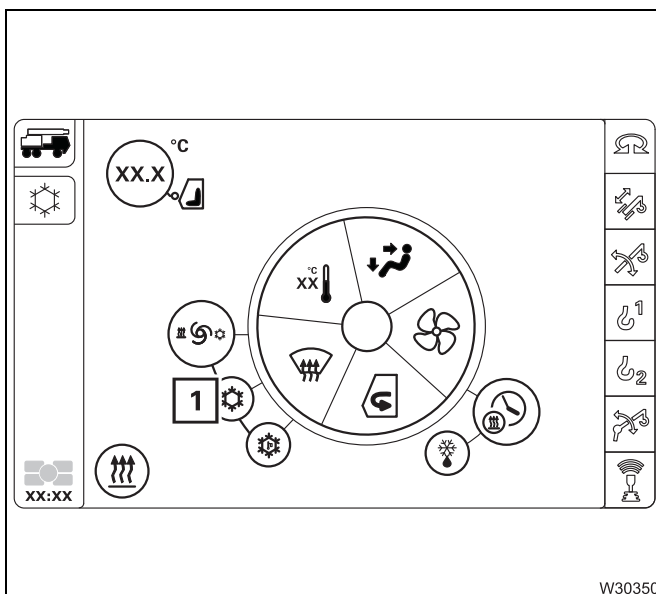

### Switching on

- Select and confirm the symbol (1) – Symbol **red**

### Switching off

- Select and confirm the symbol (1) again – Symbol **grey**



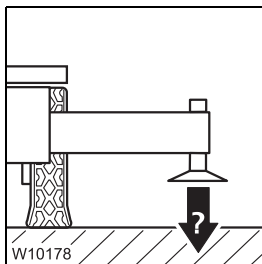

8. Check that the ground will support the maximum occurring outrigger pressures; *Determining the required load-bearing area*, p. 12 - 11.

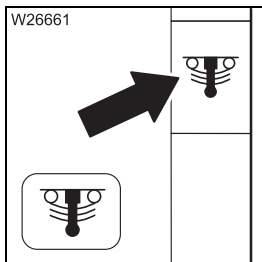

9. Switch off (lock) the suspension.  
The symbol must be **red** (suspension off); p. 5 - 17.

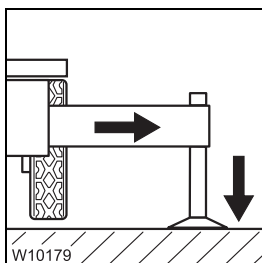

10. Support the truck crane with the outrigger span required for the job according to the *Lifting capacity table* and raise until none of the wheels is touching the ground; *Outrigger*, p. 12 - 29.

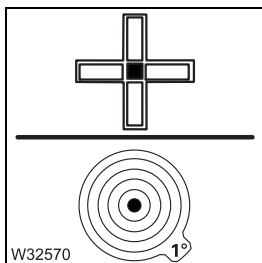

11. Align the truck crane horizontally; p. 12 - 50.

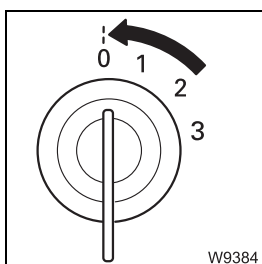

12. Switch off the engine; *Switching off the engine*, p. 10 - 13



### Load-bearing area

- Now calculate the required load-bearing area.
- Check that the surface of the outrigger pad (▮▮▮▮▶ p. 1 - 14) is larger than the calculated load-bearing area. If the surface of the outrigger pad is smaller, you will need to enlarge the load-bearing area.



### **Danger of overturning if the load-bearing area is too small!**

Ensure that the actual load-bearing area is at least as large as specified in the table.

This prevents the ground giving way and the truck crane overturning.

---

Example for calculating the required load-bearing area:

If the outrigger pressure is 25 t and the ground has a load bearing capacity of 40 t/m<sup>2</sup>. then the required load-bearing area for this supporting cylinder is 0.625 m<sup>2</sup> (= 6,250 cm<sup>2</sup>).

If the outrigger pad has a surface of 2.000 cm<sup>2</sup>, you would need to enlarge the load-bearing area by placing packing under the outrigger pads; ▮▮▮▮▶ p. 12 - 45.

---

## 12.4

# Connecting/disconnecting the hand-held control

## Functionality of the sockets

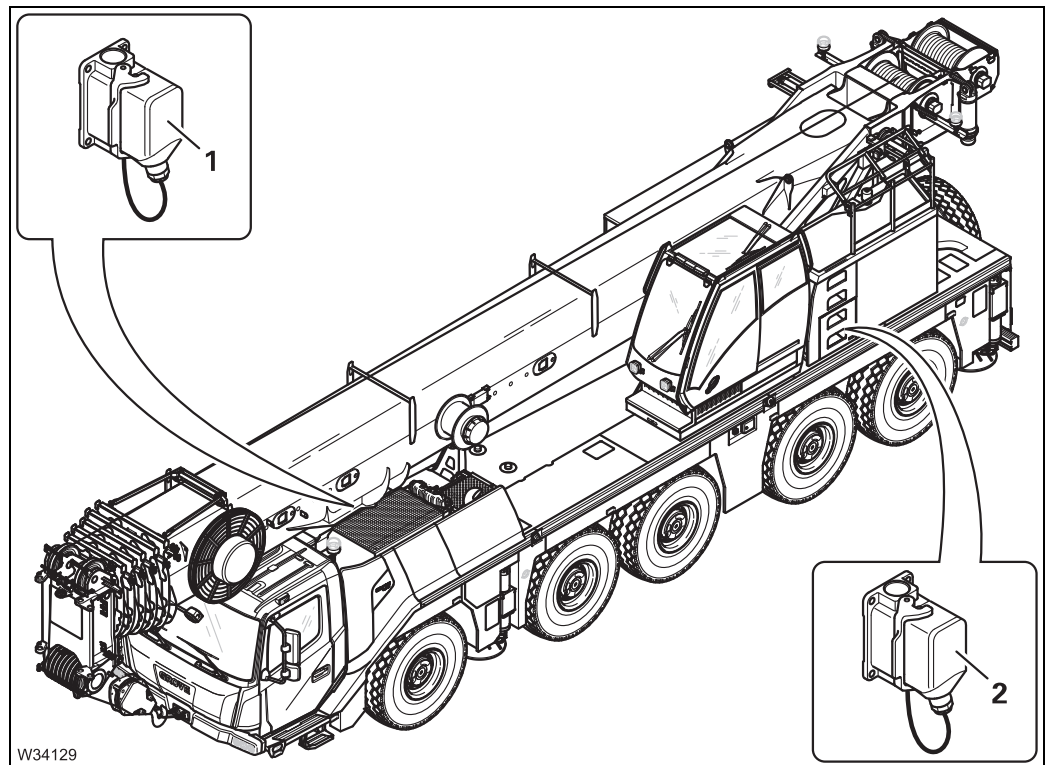

The hand-held control is only active when it is connected to the sockets (1) or (2).

Released operations	
<b>1</b>	<ul style="list-style-type: none"> <li>- Emergency operation for crane movements (except for telescoping mechanism)</li> <li>- Derrick lattice extension<sup>1)</sup></li> </ul>
<b>2</b>	<ul style="list-style-type: none"> <li>- Emergency operation for crane movements</li> </ul>

<sup>1)</sup> Additional equipment



Switch off the engine. Pulling a bridging plug will shut the engine off, but this action is only designed for emergencies. The ignition can be switched on or off.



## 12.6.4

### Preparing the truck crane

#### Driver's cab

#### Levelling the truck crane

- Align the truck crane horizontally with the level adjustment system;  
    ▮▮▮▮▶ *Operating the level adjustment system*, p. 5 - 61.

#### Locking the suspension

- Switch off the suspension; ▮▮▮▮▶ *Switching the suspension on/off*, p. 5 - 16.

The operating elements for the outriggers are only released if the suspension is switched off. If the suspension is switched off, the wheels are lifted when the crane is put on outriggers.

#### Crane cab

The outriggers can be moved from the crane only when:

- the suspension is switched off,
- the parking brake is applied,
- the slewing gear is switched off.

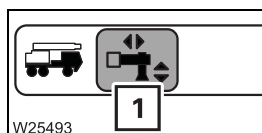

- Open the *Outrigger* menu (1) if necessary.



## 12.6.7

### Moving the outrigger pads into operating/driving position

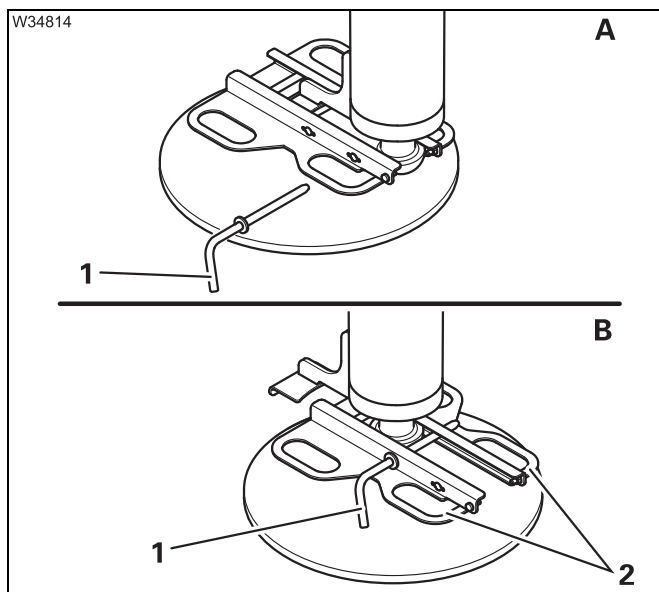

#### Moving them into working position

- (A) – Pull out the pin (1).
- (B) – Pull the outrigger pad outwards by the handle (2).
- Secure the outrigger pad with the pin (1).
- Secure the pins (1).
- Move the other outrigger pads into operating position in the same way.

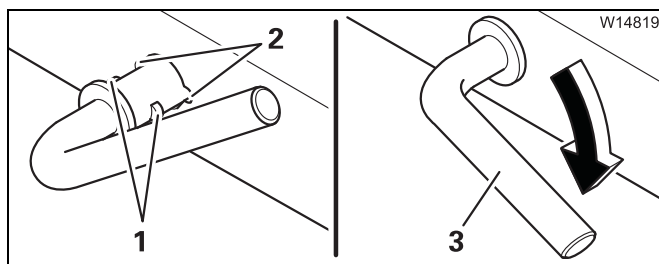

#### Securing pin

- Plug the pin with the peg (1) through the cutout (2).
- Turn the handle (3) downward.

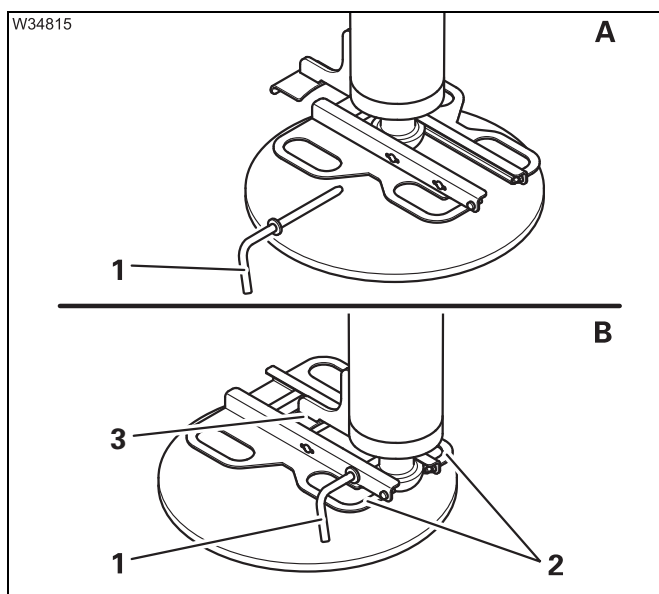

#### Moving into driving position

- (A) – Pull out the pin (1).
- (B) – Pull the outrigger pad by the handle (2) onto the holder (3).
- Secure the outrigger pad with the pin (1).
- Secure the pins (1).
- Move the other outrigger pads into driving position in the same way.

## Automatic alignment

During the automatic alignment procedure, the supporting cylinders are **extended** only to prevent any wheels touching the ground after the alignment.

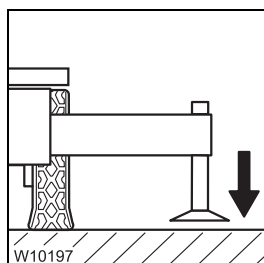

- Check that the prerequisites are met; ▮▮▮▮ p. 12 - 51.
- Extend the supporting cylinders until the outrigger pads are just above the ground.

### Starting procedure

Depending on the truck crane's equipment, you can start the procedure from the hand-held control and the *Outrigger* control units.

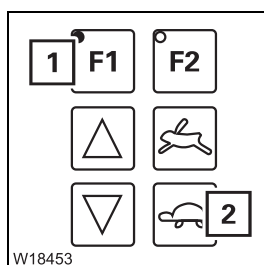

On the control units

- Press the button (1).
- Additionally, press the button (2).

The procedure begins.

### Automatic procedure

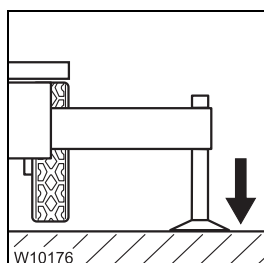

1. All the supporting cylinders are extended one after the other until the outrigger pads touch the ground.
2. All the supporting cylinders are extended simultaneously so that none of the wheels is touching the ground any more.

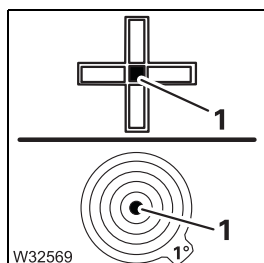

3. The truck crane is automatically levelled horizontally.

This procedure is performed:

- until horizontal alignment is reached, the lamp (1) in the centre is the only one lighting up in measuring range 1° **or**
- until you let go of a button **or**
- until horizontal alignment is no longer possible, e.g. when a supporting cylinder is extended as far as possible.



### **Danger of overturning if the truck crane is not level!**

When CCS ends the automatic alignment procedure, the truck crane is not necessarily level.

Always check the horizontal alignment on the inclination indicator after automatic levelling.

## 12.7.4

### Slings points on the counterweight sections



#### Risk of accidents if used improperly!

Attach the lifting gear to various counterweight section only at the appropriate slinging points. Ensure the lifting gear has sufficient load bearing capacity.

Only lift the sections one by one, since the slinging points are not designed for lifting stacked sections.

- Only use lifting gear of sufficient load bearing capacity. Weights;  *Counterweight parts*, p. 1 - 11.

#### Sections

- Attach the counterweight sections at the slinging points (1).

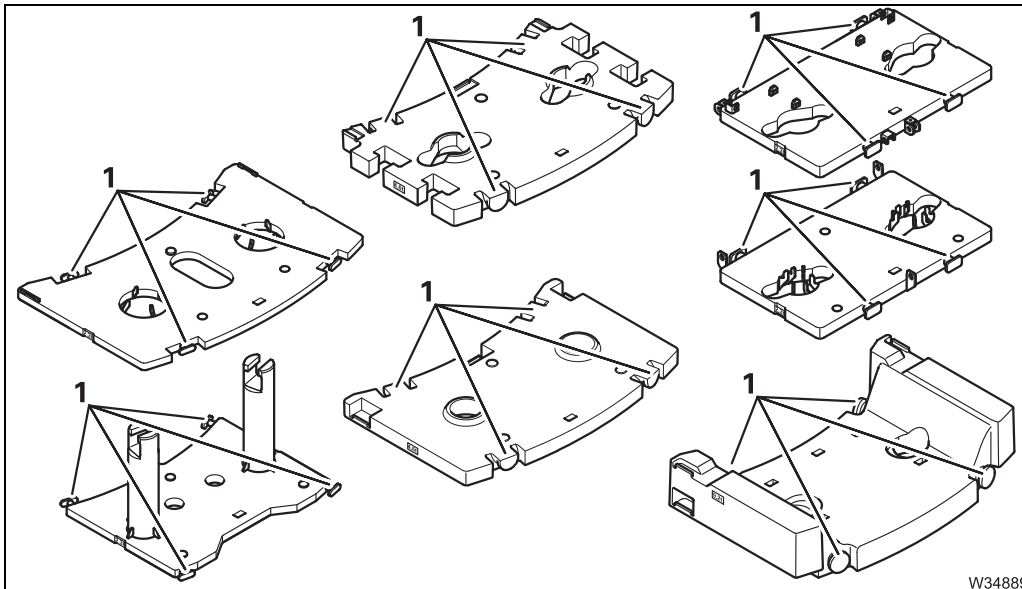

W34889

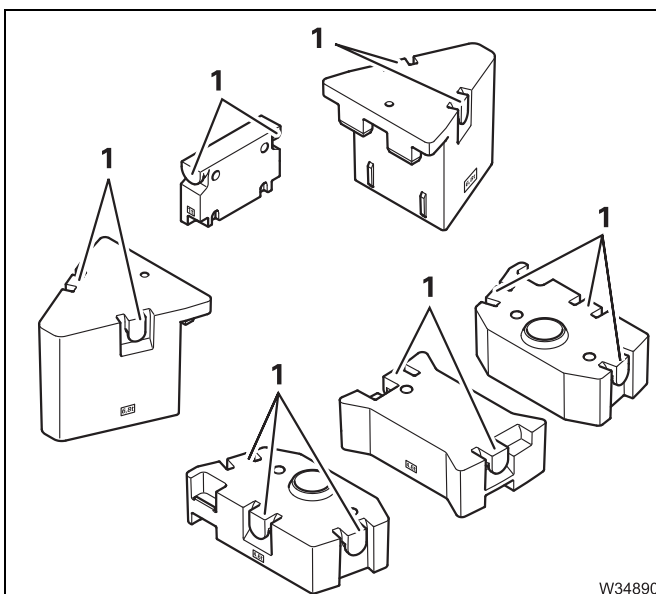

W34890

#### Blocks

- Sling the blocks at the slinging points (1).

The illustration and the table show all counterweight sections and all counterweight combinations that can be rigged.

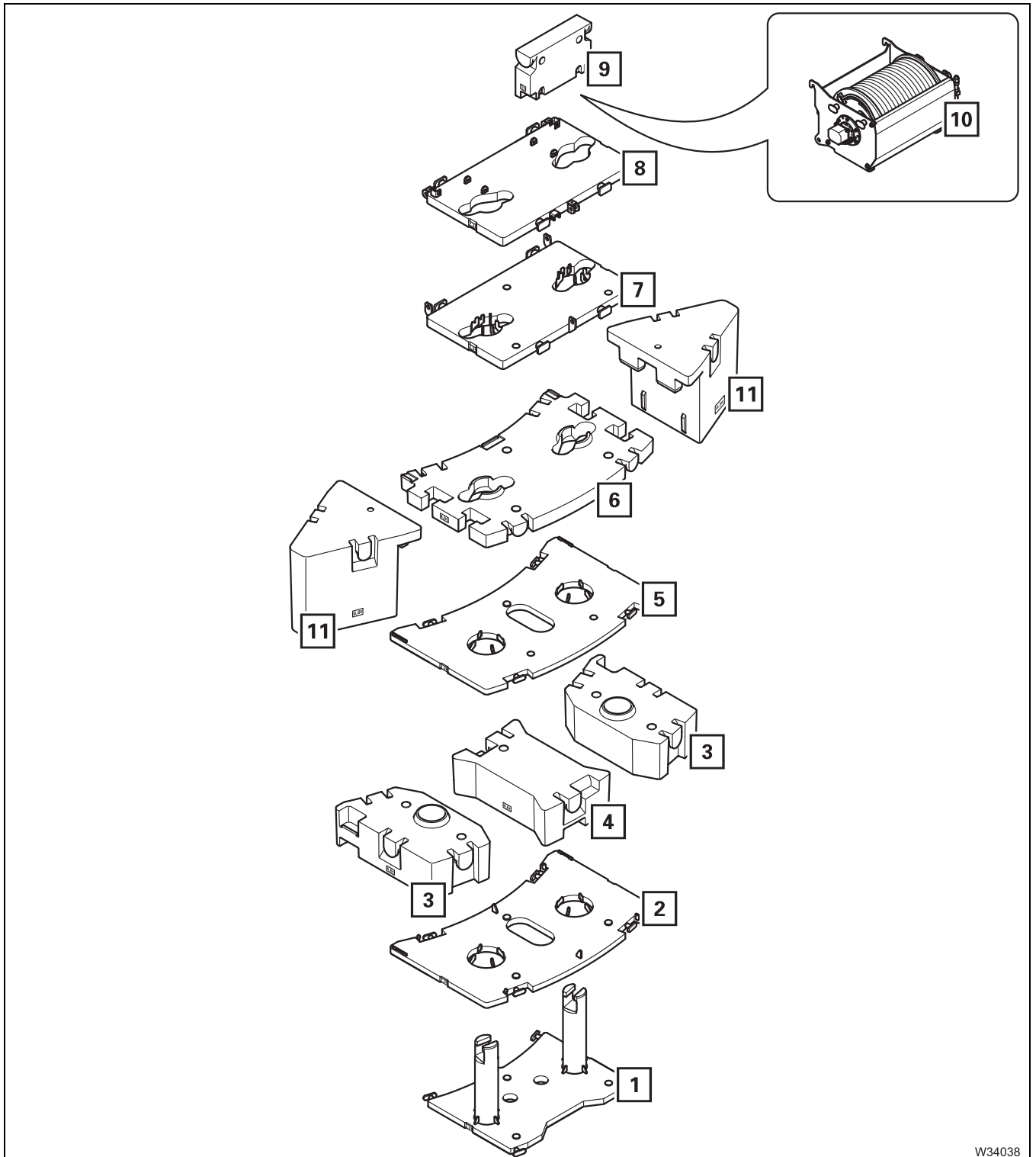

W34038

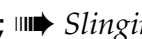
- Lift the counterweight sections on to the base plate;  *Sliding points on the counterweight sections, p. 12 - 63.*

03.07.2017



**Version 3**

The illustration and the table show all counterweight sections and all counterweight combinations that can be rigged.

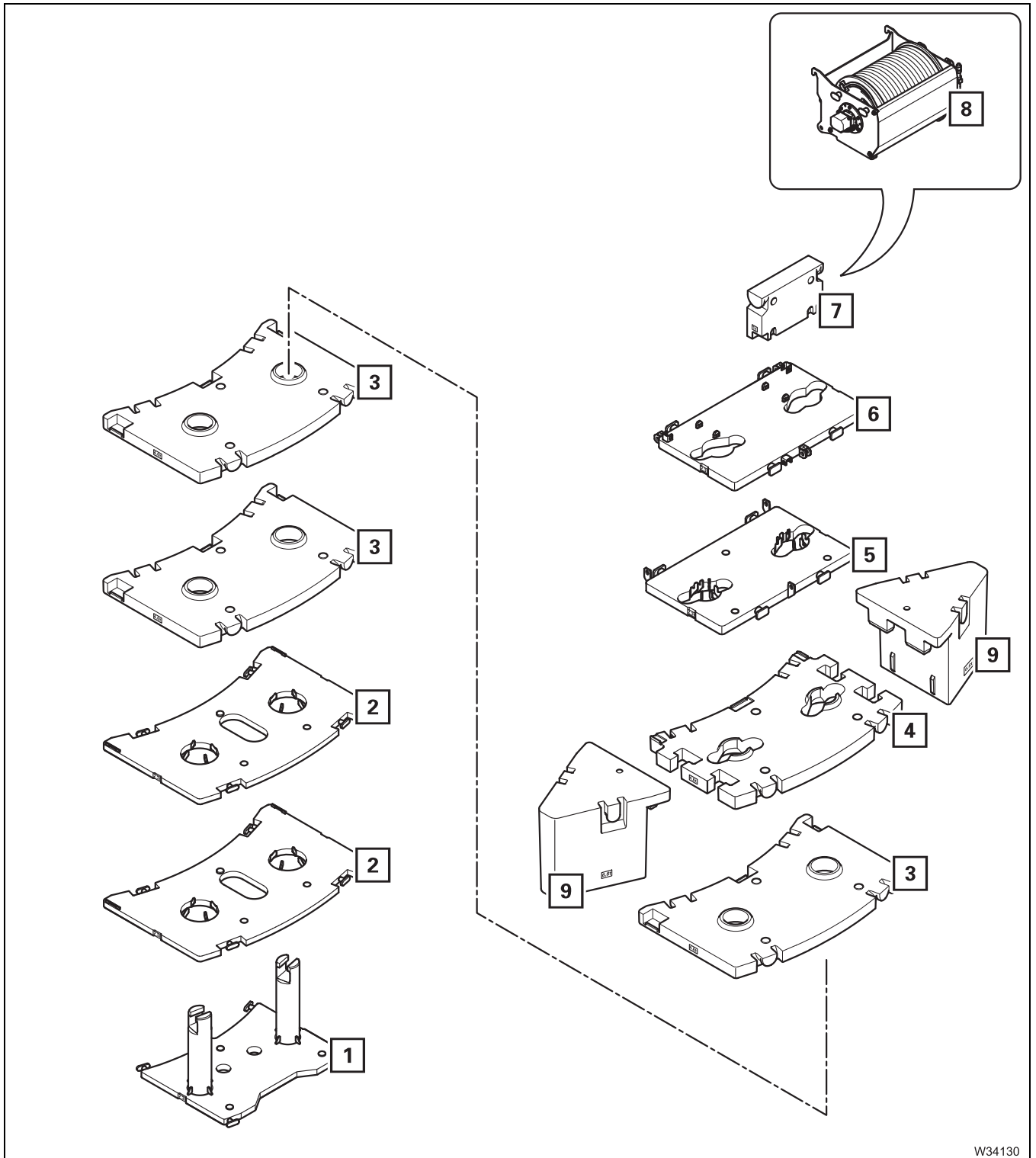

W34130

- Lift the counterweight sections on to the base plate;  *Sliding points on the counterweight sections, p. 12 - 63.*

03.07.2017



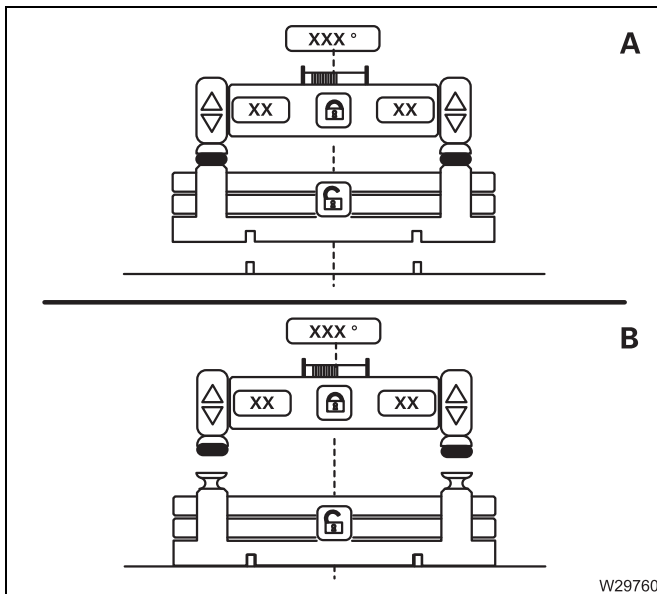

### Correct the rigging mode

- You can use the automatic mode only if the current rigging mode is displayed.

- A** Counterweight rigged
- B** Counterweight unrigged

If necessary, correct the displayed rigging mode as follows:

- Slew the superstructure out of the rigging range so that the lifting cylinders can be freely extended.

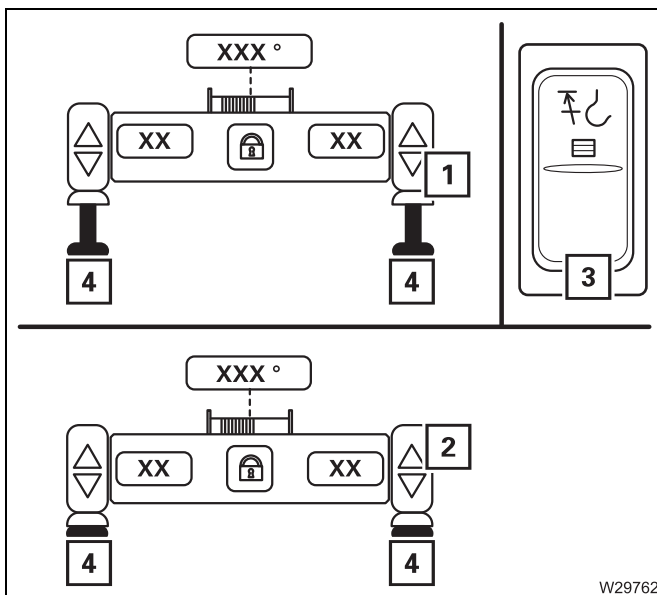

Assuming the symbol (4) is yellow with the counterweight unrigged.

- Press in the override button (3).
- (A)** Fully extend the lifting cylinders – symbol (1).
- Release the override button (3).
- (B)** – Fully retract the lifting cylinders – symbol (2).

The symbols (4) become green.

You can now use the automatic mode.



## 12.7.11 Slewing with the rigged counterweight

Slewing with a rigged counterweight is only permissible when:

- The necessary outrigger span is rigged,
- The respective RCL code is shown, and
- The permissible working radius according to *Lifting capacity table* is maintained.



### **Danger of overturning when slewing with an incorrectly set RCL!**

Always check before slewing whether the RCL code valid for the current rigging mode is displayed.

This prevents slewing operations being released within impermissible ranges and the truck crane from overturning.



### **Risk of overturning when operating with the hand-held control!**

When operating with the hand-held control, there is no monitoring by the RCL. Before slewing, always check using the following table whether slewing is permissible.

This prevents the truck crane overturning while slewing.

The following table specifies (depending on the counterweight and outrigger span) whether slewing the superstructure is:

- Permitted
- Only permitted for certain working radii
- Disabled (with the correct rigging mode).



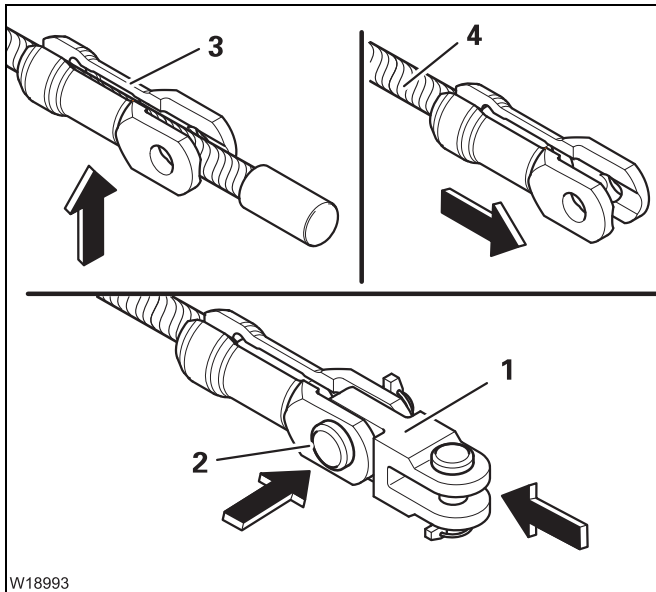

W18993

### Positioning

- Insert the holder (3) and slide it onto the hoist rope (4) as far as it will go.
- Fasten the fork (1) using the pin (2).
- Secure the pin.

### Version B

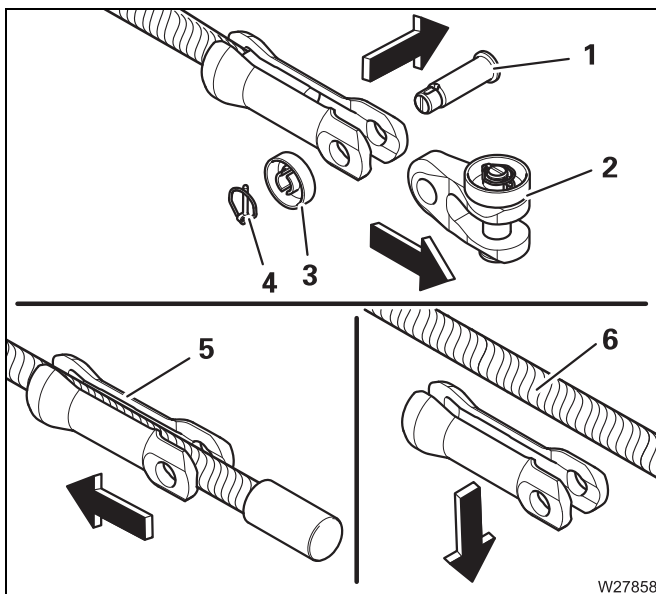

W27858

### Removing the hoist rope

- Remove the linchpin (4).
- Release the locknut (3) and pull out the pin (1). Remove the bracket (2).
- Slide the pocket lock (5) back and remove it from the hoist rope (6).



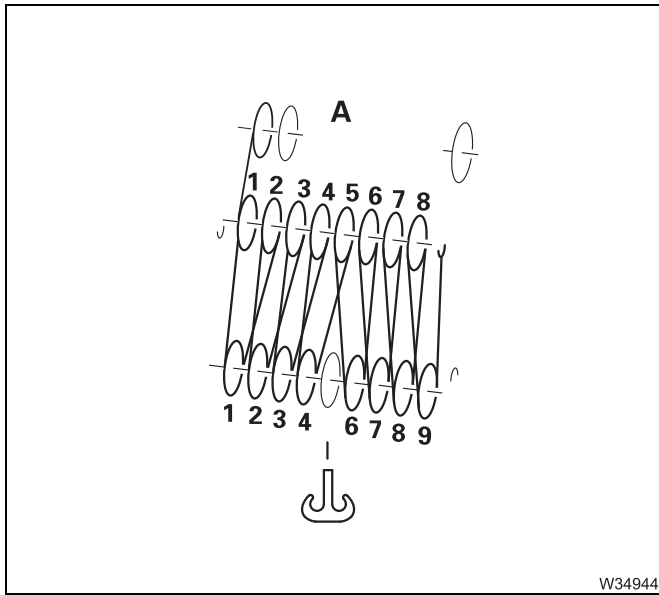

### 9 sheave hook block

Reeving  
**A** 16x

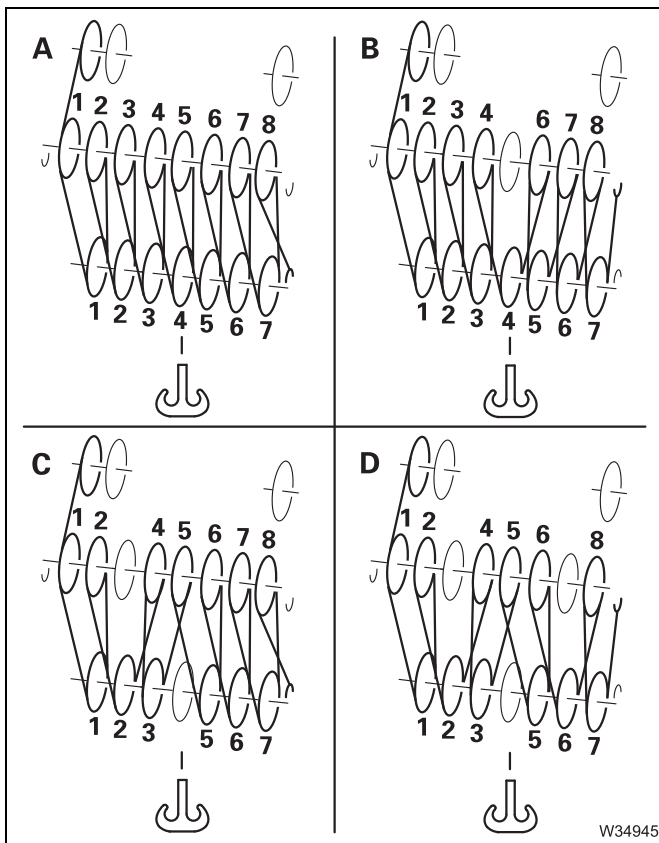

### 7 sheave hook block

Reeving  
**A** 15x  
**B** 14x  
**C** 13x  
**D** 12x



## 12.8.8

### Anemometer and air traffic control light

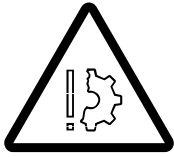

#### Risk of damage during on-road driving

Always remove the anemometer and air traffic control light before on-road driving.

This prevents the specified overall height being exceeded at on-road level, and the anemometer from getting damaged due to unfavourable air currents.

#### Installing

The anemometer and the air traffic control light – if provided – are located on the same rod.

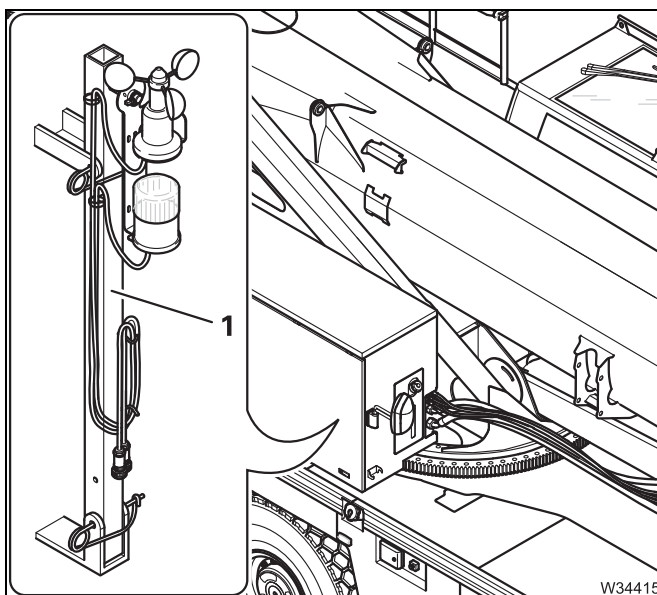

- If necessary, remove the rod from the storage compartment (1).

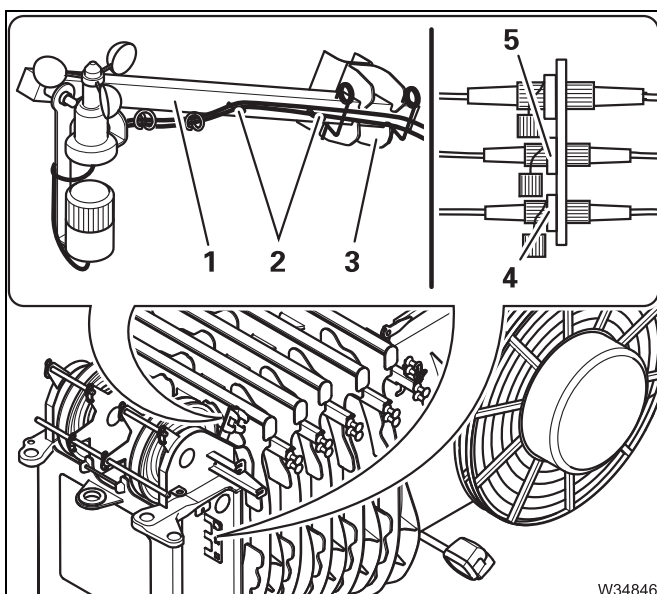

- Insert the rod (1) into the holder (3) and secure it with the retaining pins.
- Remove the cable from the holders (2) and connect
  - the anemometer to the socket (4),
  - the air traffic control light to the socket (5).
- Lay the cables in such a way that they will not be damaged during crane operation.
- Check that the anemometer is able to swing so that it hangs vertically even when the main boom is raised.



## 12.9.4

### Step for the crane cab

You can operate the step in the *Crane cab* menu or on the outrigger control unit.



#### **Risk of accidents by exceeding the permissible overall width!**

Always retract the step for on-road driving.

When the step is extended, the overall width specified for on-road driving is exceeded.



You can only extend the step at the control unit when you are on the operator side.

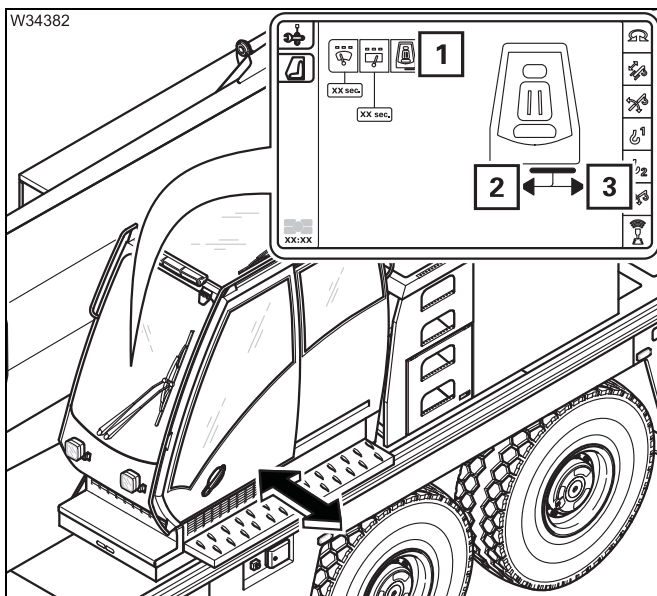

#### **In the *Crane cab* menu**

Select extend/retract step as necessary – (1).

#### **Extend**

- Select and confirm the symbol (3) – the step extends.

#### **Retract**

- Select and confirm the symbol (2) – the step retracts.

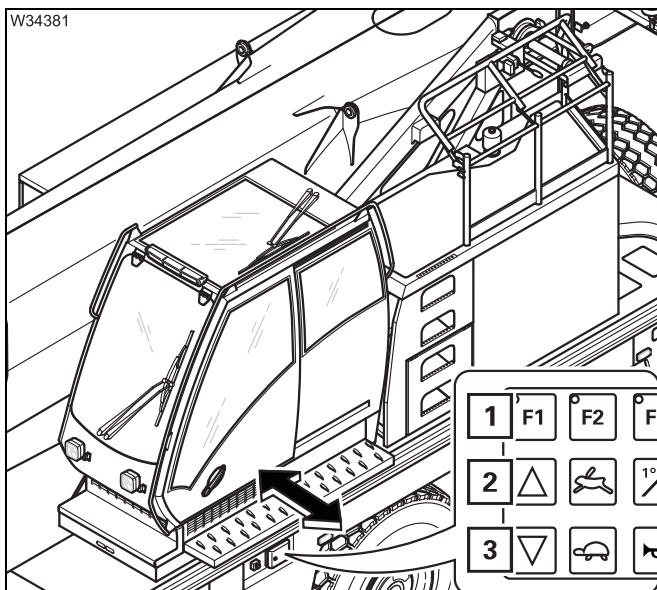

#### **On the outrigger control unit**

#### **Extend**

- Press the buttons (1) and (3) – the step extends.

#### **Retract**

- Press the buttons (1) and (2) – the step retracts.

### 13.3.3

## Putting the truck crane on the wheels



### Danger of overturning by unevenly retracting the outrigger cylinders!

Retract the outrigger cylinders evenly! This prevents the truck crane from overturning while retracting individual outrigger cylinders.



### Risk of damage to the axle lines!

Retract the outrigger cylinders evenly! This prevents excessive strain on the axle lines.

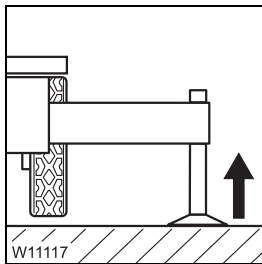

- If necessary, retract the outrigger cylinders until all wheels are just above the ground.



### Danger of overturning when switching on the suspension!

You may under no circumstances switch on the suspension while the rigged truck crane is on wheels. Switching on the suspension would cause the suspension struts to be suddenly collapsed and damaged, and the truck crane could overturn.

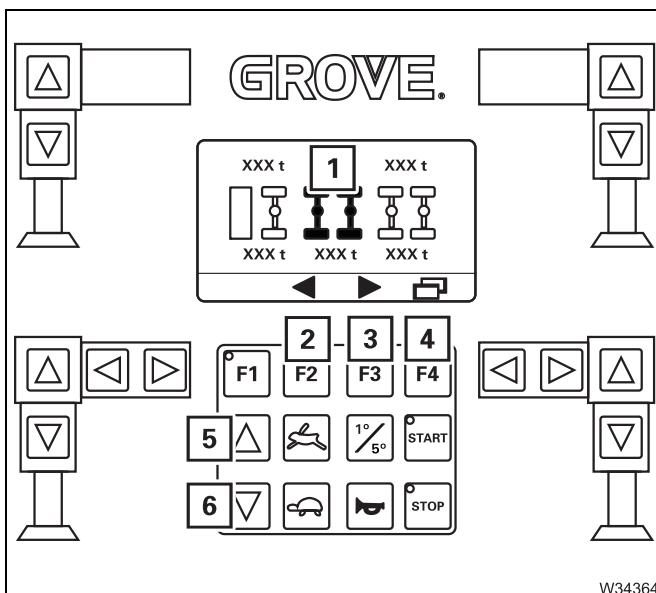

### Lowering/raising the axles

- Open the Raise Axle menu – button (4).
- Select the axles to be lowered by pressing button (2) or (3).
- The selected axles (1) are displayed in black.
- Press the button for the desired movement:
  - 5 Raise the axles
  - 6 Lower the axles

### 13.5.3

## Steering

### Switching on

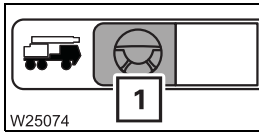

Opening the menu (1) switches on normal steering mode.

### Steering direction

The steering direction is adjusted automatically to suit.

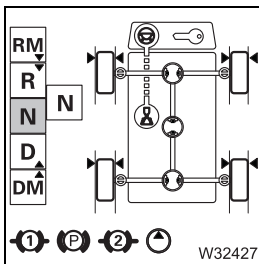

#### - Turned to the front

The buttons' direction of movement corresponds to the steering direction of the truck crane if the superstructure is in the  $180^\circ$  to the front position.

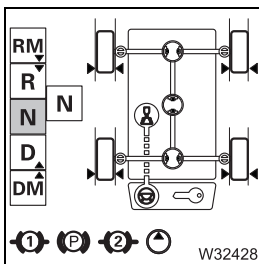

#### - Turned to the rear

The buttons' direction of movement corresponds to the steering direction of the truck crane if the superstructure is in the  $0^\circ$  to the rear position.



## 13.5.7

### After driving

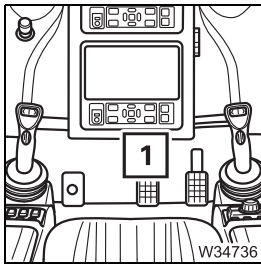

- Bring the truck crane to a halt with the brake pedal (1).

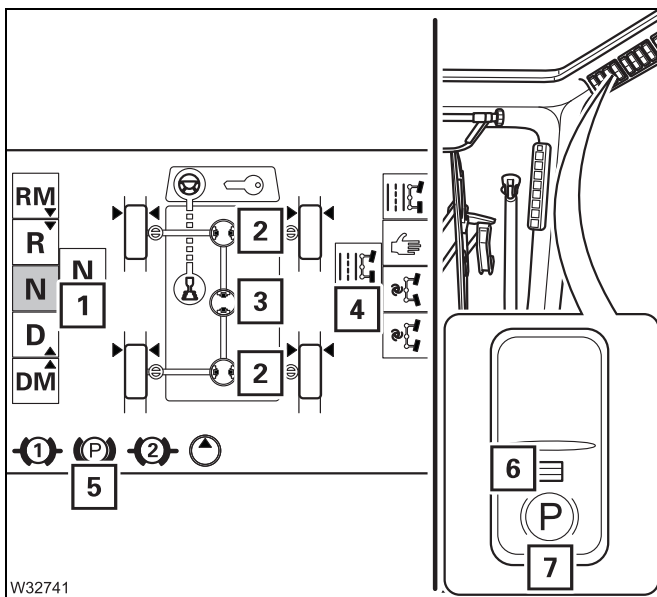

- Restore the original condition:
  - Switch the transmission to neutral position (1)
  - Switch off longitudinal differential lock off (3),
  - Switch off transverse differential locks (2),
  - Switch on normal steering mode (4).
- Press button (7) in at the bottom once. The lamp (6) lights up, symbol (5) is red – the parking brake is applied.

- If necessary, switch the engine off; Switching off the engine, p. 10 - 13.
- Remove the ignition key from the ignition lock in the driver's cab and lock the driver's cab to prevent unauthorised access.

Support the truck crane on outriggers if you do not intend to work in the *Free on wheels* working position.

Designation	Amperage (A)	Function
F2/1	15	Control unit UB 1 IOL 30
F2/2	15	Control unit UB 2 IOL 30
F2/3	15	Control unit UB 2 IOL 30
F2/4	15	Control unit UB 1 IOL 34
F2/5	15	Control unit UB 2 IOL 34
F2/6	15	Control unit UB 2 IOL 34
F2/7	15	Control unit UB 2 IOL 34
F2/8	–	Unassigned

Designation	Amperage (A)	Function
F3/1	–	Unassigned
F3/2	–	Unassigned
F3/3	–	Unassigned
F3/4	3	Contact switch for cab lighting
F3/5	5	CCS display
F3/6	5	Hand-held control
F3/7	7.5	Comfort seat <sup>1)</sup>
F3/8	5	Cigarette lighter

<sup>1)</sup> Additional equipment



### 14.4.11 Malfunctions on the counterweight hoist unit

Malfunction		Cause	Remedy
<b>Counterweight hoist unit is not working</b>		Emergency stop switch on	▶ <i>Resetting the emergency stop switch</i> , p. 4 - 22
		Control unit fuse blown	Replace blown fuse;    ▶ p. 14 - 5
<b>Error symbol (!) is displayed</b>		Function disabled by CCS	If necessary, acknowledge error message once and briefly switch off the ignition – if error persists, notify <b>Manitowoc Crane Care</b>
		Electronic system has detected an electrical or logical error	
<b>Extend lifting cylinder not working</b>		Superstructure unlocked	▶ <i>Locking the superstructure</i> , p. 11 - 16

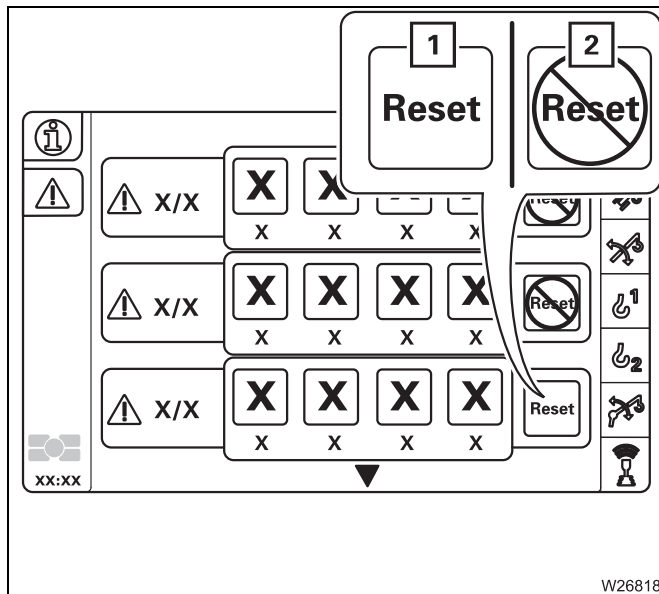

### To acknowledge the error

Display symbol (1) – error can be acknowledged

Display symbol (2) – error cannot be acknowledged

- Select and confirm symbol (1) to acknowledge the error.

If the error cannot be acknowledged, consult **Manitowoc Crane Care**.

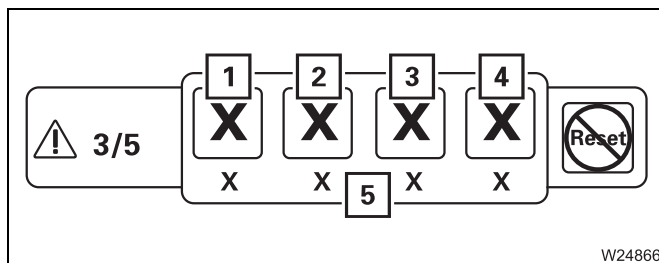

### Error message display

For each error the display shows:

- the error code (5),
- the symbols for
  - 1 the faulty component
  - 2 the error type
  - 3 the control unit which detected the error
  - 4 the index in the error group

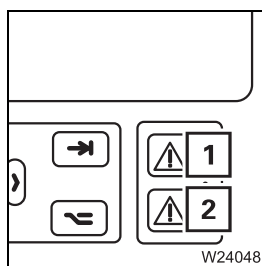

When all errors are acknowledged, the lamps (1) and (2) go out.

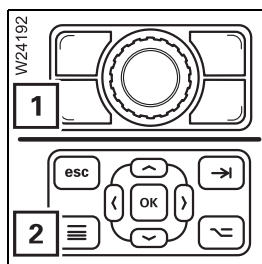

### Exiting the menu

You can exit the *Errors* menu at any time.

- Press the button (1) or (2) once.

The next highest menu is opened.

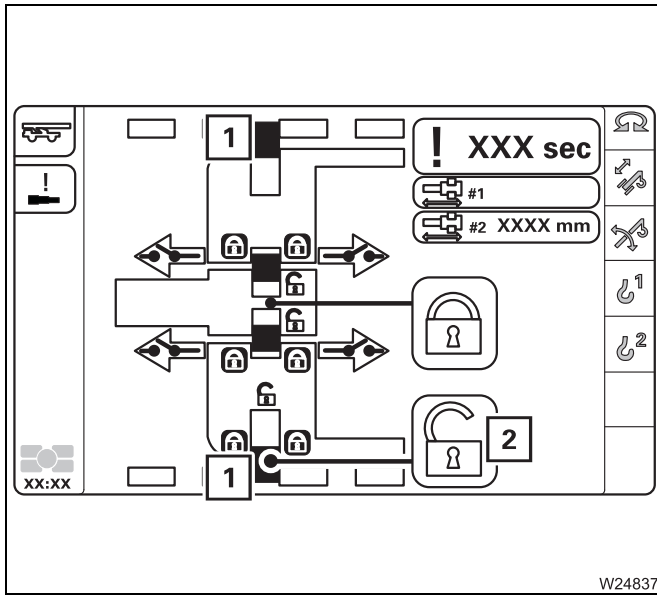

- Retract the telescopic section slowly and as far as possible; *Locking points for the telescopic sections*, p. 14 - 40.

- Extend to approx. 28 mm (0.09 ft).
- Select and confirm the symbol (2).

The telescopic section is now locked. In the *Locked* position Locked, the locking pins (1) are **green**.

- Set down the telescopic section and retract it as far as it will go.

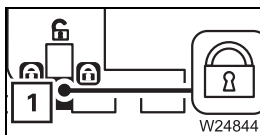

### Unlocking the telescoping cylinder

If the telescopic section (1) is locked, you can now unlock the telescoping cylinder.



### Risk of accidents from sudden retraction of a telescopic section!

You can select and confirm the symbol for unlocking the telescoping cylinder only a **maximum of 2 times**. If this does not start the unlocking procedure, contact **Manitowoc Crane Care**.

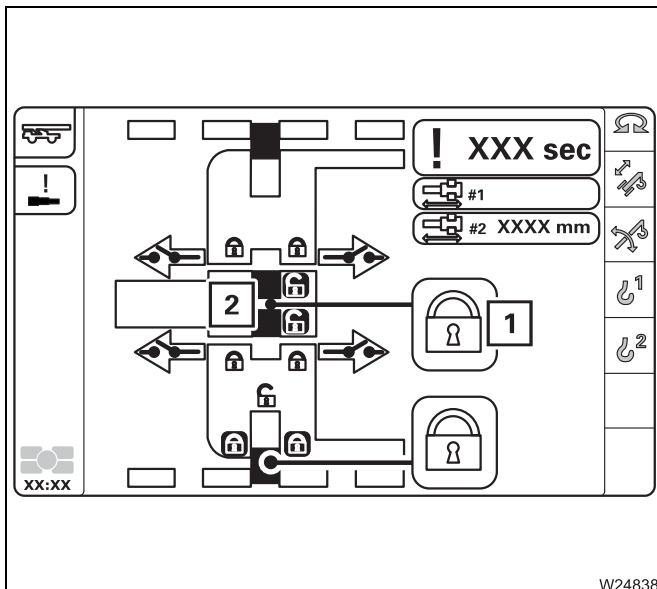

- Select and confirm the symbol (1).

The telescopic cylinder is now unlocked. In the *Unlocked* position, the locking pins (2) are **red**.

You can now move the telescopic cylinder into the next telescopic section; *Locking points for the telescoping cylinder*, p. 14 - 39.



## 14.6

## Hydraulic emergency operation



This section only applies to the standard hydraulic emergency operation. If the truck crane is equipped with an hydraulic **emergency operation system to BGR 159**;  p. 14 - 52.

In hydraulic emergency operation, you can operate the derricking gear and the main hoist, e.g. to raise the main boom in the case of a defective engine.



### Risk of accidents due to improper use!

Use hydraulic emergency operation only to transport small loads in emergencies. Have the malfunction rectified as soon as possible. Crane operation in hydraulic emergency operation is prohibited since it is not monitored by the RCL.

### Switching over valves

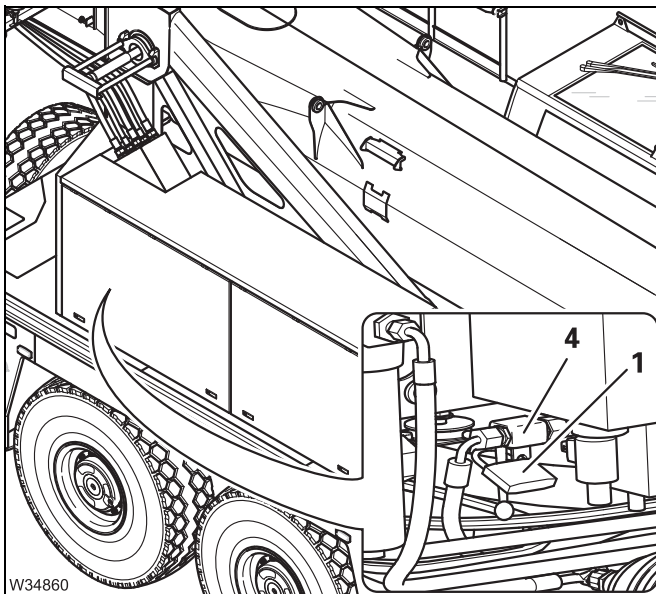

### On the crane's hydraulic system:

#### For crane operation

- Close the valve (4). Secure the valve with the lock (1).

#### For emergency operation

- Remove the lock (1). Open the valve (4).



### For lifting/ lowering

After establishing the hydraulic circuits you must also:

- switch one valve permanently on,
- connect one valve to the hoist.

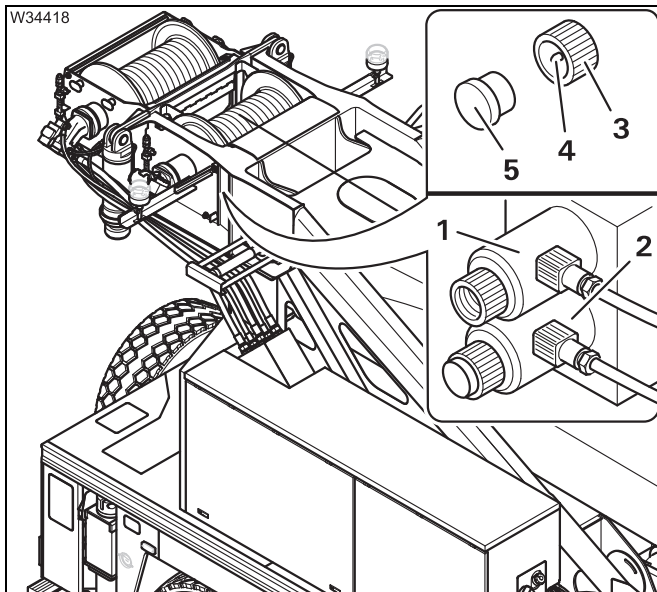

### Switching on continuous operation

Always switch only **one** valve to continuous operation.

- 1 Valve Y1104 – Lowering **or**
- 2 Valve Y1105 – Lifting

- Unscrew the cap (3) e.g. from the valve (1).
- Remove the plug (5).
- Screw the cap and pin (4) on to the valve – continuous operation is now switched on.



### Danger due to falling loads!

Switch off continuous operation immediately after emergency activation. Check whether the pins can be seen on both caps. Thus you prevent loads from falling down immediately after lifting in subsequent crane operation.

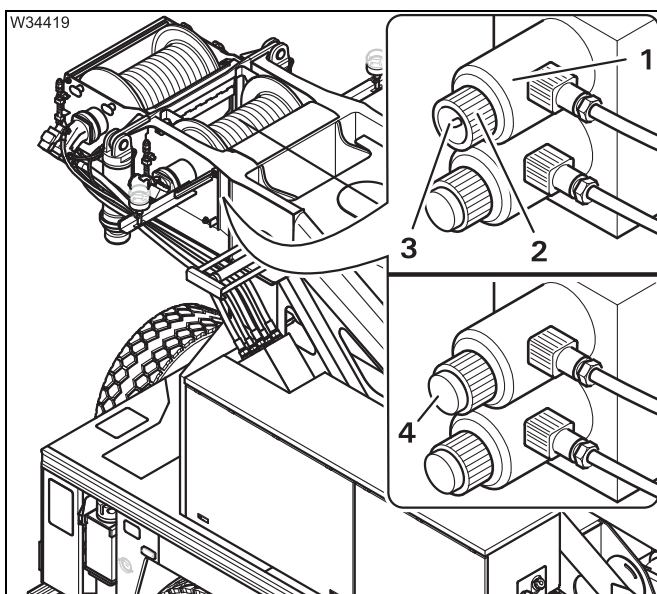

### Switching off continuous operation

- Unscrew the cap (3) from the actuated valve (1), (2).
- Screw the cap on so that the pin (4) can be seen.
- Insert the plug (5).



<b>A</b>	<b>AdBlue system</b>	
	Operating elements in the crane cab	9 - 92
	Operating elements in the driver's cab	3 - 48
	Superstructure - overriding torque reduction	11 - 113
	<b>Adjust the mirrors</b>	
	for driving	5 - 7
	on the superstructure	12 - 137
	<b>Air intake inhibitor</b>	4 - 23
	<b>Air-conditioning system</b>	
	In the crane cab	11 - 135
	in the driver's cab	5 - 76
	<b>Auxiliary hoist</b>	11 - 59
	Brief description of the operating elements	9 - 112
	<b>Installing/removing</b>	
	Checking the function	6 - 49
	<b>Checklist</b>	
	Installation	6 - 42
	Removal	6 - 43
	electrical connection	6 - 46, 6 - 47
	hydraulic connection	6 - 45
	Making/breaking the connection between the auxiliary hoist and the turntable	6 - 44
	Slinging points	6 - 41
	Transport	6 - 48
	Lifting and lowering	11 - 60
	Switch off	11 - 61
	Switch on	11 - 59
	<b>Axle loads</b>	
	Required speed limit	6 - 6
	Weighing the truck crane	6 - 7
	<b>Axle loads when driving the rigged truck crane</b>	13 - 5
<b>B</b>	<b>Batteries</b>	
	Battery master switch	4 - 11
	Battery charger	8 - 12
	<b>Battery master switch</b>	
	Operating elements in the driver's cab	3 - 49
	<b>BirdView system 270° degrees</b>	
	Operating elements in the driver's cab	3 - 55
	<b>Boom pre-tensioning</b>	
	Switch off	12 - 19, 12 - 21
	Switch on	6 - 13, 6 - 14
	<b>Brakes</b>	
	Additional brakes	3 - 61, 5 - 43
	Compressed-air supply after engine failure	8 - 6
	Operating elements in the driver's cab	3 - 60
	Parking brake	3 - 60

CLICK HERE TO **DOWNLOAD** THE COMPLETE MANUAL

- Thank you very much for reading the preview of the manual.
- You can download the complete manual from: [www.heydownloads.com](http://www.heydownloads.com) by clicking the link below



- Please note: If there is no response to CLICKING the link, please download this PDF first and then click on it.

CLICK HERE TO **DOWNLOAD** THE COMPLETE MANUAL