

# **DYNAPAC**

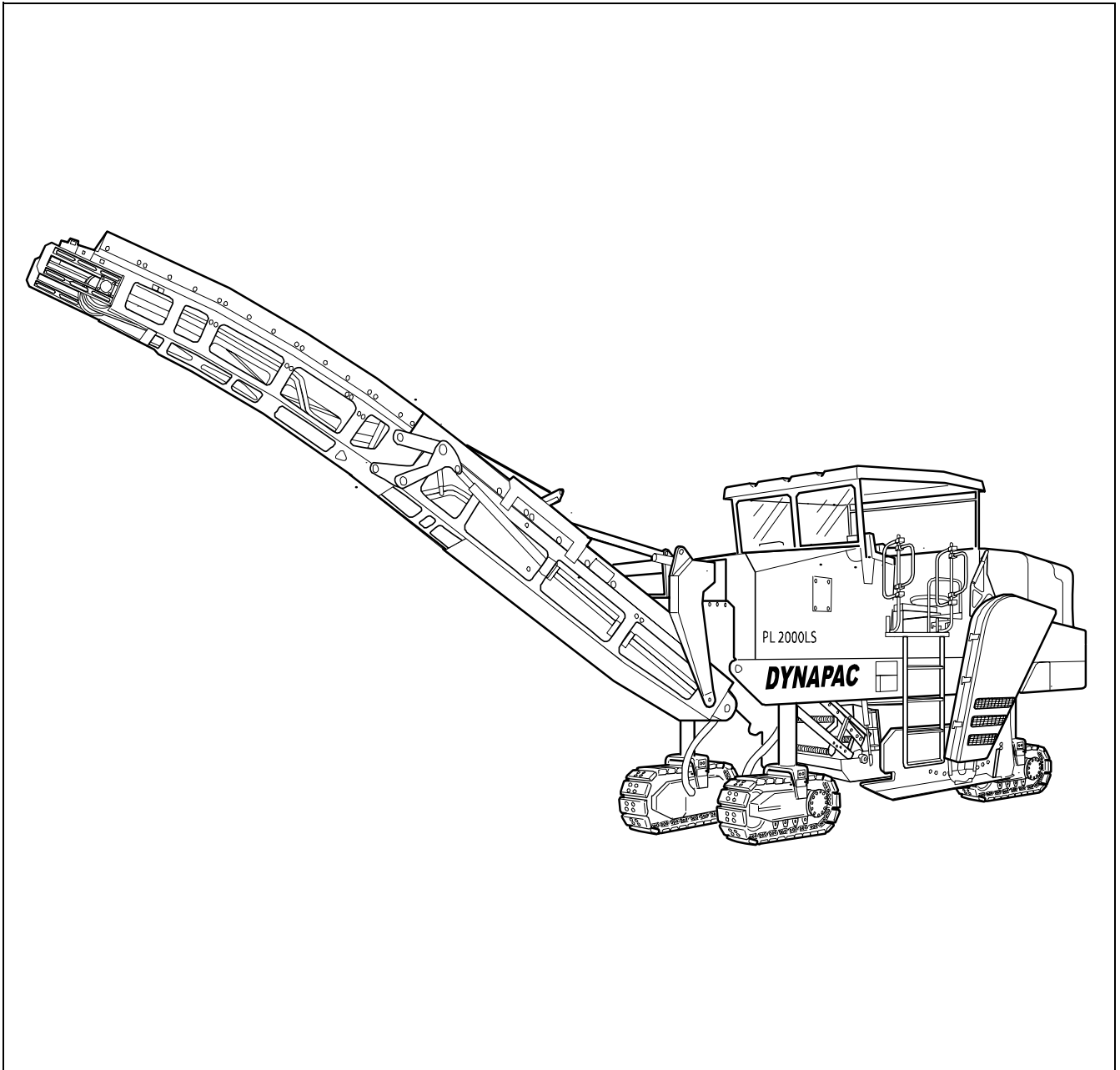

## **Operating Instructions**

GB

Valid for:

**Cold Planer  
PL 2000 S  
PL 2000 LS**

**02-06.05**

900 98 09 88

CLICK HERE TO **DOWNLOAD** THE COMPLETE MANUAL

- Thank you very much for reading the preview of the manual.
- You can download the complete manual from: [www.heydownloads.com](http://www.heydownloads.com) by clicking the link below



- Please note: If there is no response to CLICKING the link, please download this PDF first and then click on it.

CLICK HERE TO **DOWNLOAD** THE COMPLETE MANUAL

# B Vehicle description

## 1 Description of usage

The DYNAPAC cold planer PL 2000 S/PL 2000 LS is a compact, efficient large planer detachment, hydraulically driven by four steerable crawler units. It has a front loading system which is used to remove asphalt and cement layers. The milling drums are driven mechanically by power-transmission belts.

As a result of its high planing performance, we would recommend that this cold planer is used in particular when carrying out extensive redevelopment work on large and spacious roads, such as motorways, urban and country roads, car parks, airports etc.

The PL 2000 S/PL 2000 LS corresponds to the European safety standard and satisfies very stringent requirements in terms of its reliability, economic viability and environmental responsibility.

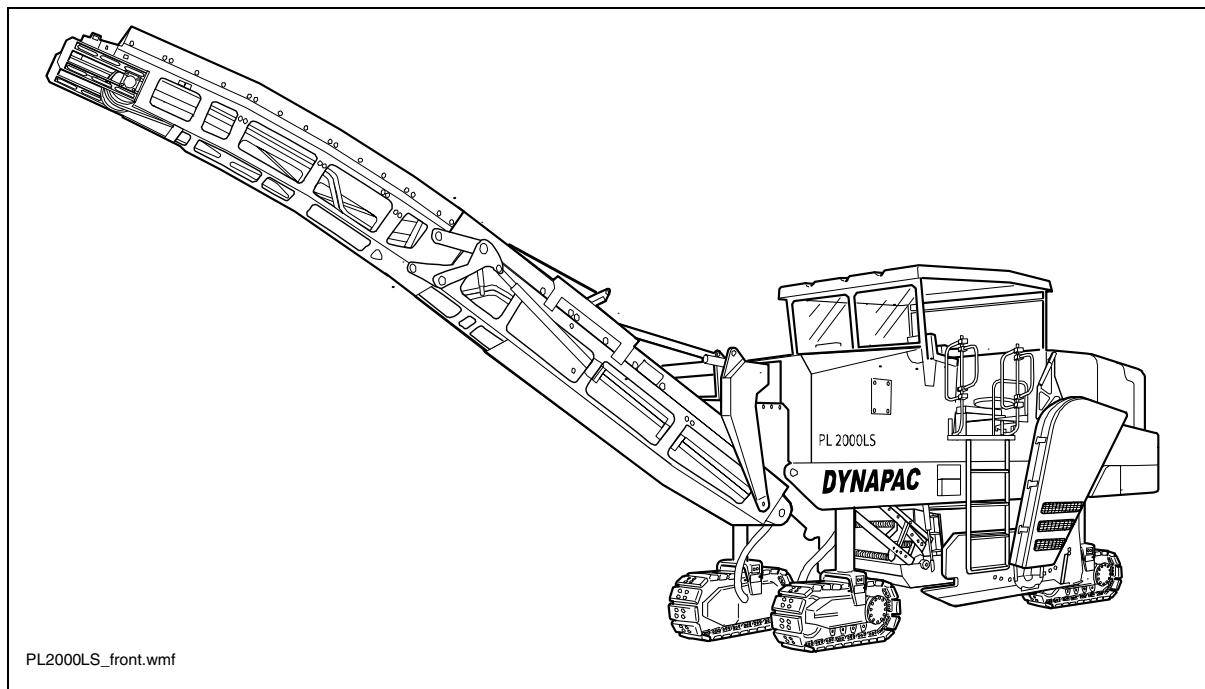

### Optional equipment:

- Extended levelling equipment: a transverse slope sensor, a digital rotary arm sensor, the ultrasound Sonic-Ski and laser receivers are contained in this package. In addition to this, a Roadscanner System can be used in conjunction with a transverse slope sensor.
- Fine spaced milling drum: cutting width 2010 mm, with welded on lug boxes which can be positioned, line spacing 7.5 mm
- Cutting section for 2100 mm cutting width with normal or fine spaced milling drum,
- Discharge conveyor with folding option: can be mechanically folded in downwards
- Weather protecting sun roof: can be mechanically or hydraulically lowered, with all-round weather protecting panel (can be folded in) and electrical windscreen wiper.
- Additional operating panel: for the machine to be operated from both sides of the operator's control station at the same time.
- Video control system: monitor and four video cameras for observing the cutting track area in front of the front drive unit, the sliding shoe area in front of the milling drum housing, the scraper flap area behind the milling drum housing and the area of the rear operating track during reverse travel. If necessary, the cameras can be swivelled and fitted differently so that the cold planer can also be steered by the machine operator by means of this video system if necessary.
- Emergency operating equipment: can be used if the main operating panel fails
- Dust suction system: extraction and filtering of dusts and harmful vapours in the following areas: cutting section, material transfer point between the lower and discharge conveyor and discharge area on discharge conveyor
- Water refilling pump by means of auto-suction recirculating pump driven by hydraulic motor, displacement quantity approx. 18m<sup>3</sup>/h
- High pressure cleaner: water lance with approx. 13 m hosing, tube reeling device, operating pressure 130 bar, water consumption approx. 38 l/min
- Pneumatic cutting tool driver: cutting tool set in toolbox, working pressure 6.3 bar, air consumption approx. 460 l/min, number of impacts 3000 p/min.
- Pneumatic piledriver: socket wrench set and extension in toolbox, working pressure 6.3 bar, air consumption approx. 580 l/min, torque 640 Nm.
- Compressed air pistol: for precision cleaning of areas difficult to access, working pressure can be adjusted between 2 -10 bar.
- Pneumatic grease press: with flexible compressed air hose, working pressure max. 8 bar, compression 480 bar (60:1)
- Spiral compressed air line: 10m in length for connecting compressed air tools



Other useful extensions and attachments are available on request.

|   | Designation   | PL 2000 S/<br>PL 2000 LS<br>Standard |       |
|---|---|--------------------------------------|-------|
| A | Machine length with max. paving height                            | 14350                                | mm    |
| B | Machine length with discharge conveyor at transport height        | 15058                                | mm    |
| C | Max. paving height  | 5018                                 | mm    |
| D | Transport height of discharge conveyor                            | any                                  | mm    |
| E | Machine length without discharge conveyor                         | 8074                                 | mm    |
| F | Height without (with lowered) weather protecting sun roof         | 3100                                 | mm    |
| G | Height with weather protecting sun roof                           | 4055                                 | mm    |
| H | Drive unit height   | 690                                  | mm    |
| I | Drive unit length   | 1890                                 | mm    |
| J | Length of drive unit suspension to start of drive unit            | 934                                  | mm    |
| K | Distance between suspension of front drive unit - milling drum    | 2900                                 | mm    |
| L | Distance between suspension of rear drive unit - milling drum     | 2100                                 | mm    |
| M | Length of drive unit suspension to end of drive unit              | 955                                  | mm    |
| N | Distance between suspension of front drive unit - rear drive unit | 5000                                 | mm    |
| O | Total distance between the drive units (incl. drive units)        | 6890                                 | mm    |
| P | Machine length with discharge conveyor folded in                  | 11479                                | mm    |
| Q | Transport height with discharge conveyor folded in                | 1657-3865                            | mm    |
| R | Track width, outer front drive units                              | 1890                                 | mm    |
| S | Chain width   | 310                                  | m     |
| T | Track width, outer rear drive units                               | 1680                                 | mm    |
| U | Machine width   | 2550                                 | mm    |
| V | Max. steering lock turn, front drive units                        | 30                                   | degr. |
| W | Max. steering lock turn, rear drive units                         | 30                                   | degr. |
| X | Turning radius  | 2065                                 | mm    |
| Y | Max. swash angle, discharge conveyor to the right                 | 45                                   | degr. |
| Z | Max. swash angle, discharge conveyor to the left                  | 45                                   | degr. |

| Item. | Spare parts no. | Comments |
|-------|-----------------|----------|
| 1     | 956.05.20.02    |          |
| 2     | 956.05.20.15    |          |
| 3     | 956.05.30.08    |          |
| 4     | 956.05.30.02    |          |
| 5     | 956.05.20.03    |          |
| 6     | 956.05.20.01    |          |
| 7     | 956.05.20.04    |          |
| 8     | 956.05.30.03    |          |
| 9     | 956.05.10.04    |          |
| 10    | 990.00.02.25    |          |
| 11    | 956.05.20.13    |          |
| 12    | 956.05.10.03    |          |
| 13    | 956.05.10.05    |          |
| 14    | 956.05.20.07    |          |
| 15    | 956.05.30.07    |          |
| 16    | 956.05.30.06    |          |
| 17    | 956.05.30.05    |          |
| 18    | 956.05.30.04    |          |
| 19    | 956.05.30.44    |          |
| 20    | 956.05.20.05    |          |
| 21    | 956.05.30.41    |          |
| 22    | 956.05.30.43    |          |
| 23    | 956.05.30.42    |          |
| 24    | 956.05.20.10    |          |
| 25    | 990.00.01.11    |          |
| 26    | 956.05.10.01    |          |
| 27    | 956.05.30.14    |          |
| 28    | 956.05.20.11    |          |
| 29    | 956.05.20.14    |          |
| 30    | 990.00.04.01    |          |
| 31    | 956.05.10.02    |          |
| 32    | 956.05.20.12    |          |

## 5 Articulation procedure of foldable discharge conveyor (O)

### 5.1 Folding in the discharge conveyor

The transport length of the machine can be significantly reduced using the foldable discharge conveyor (available as an option).

Various operations are required and conditions should be checked and/or set to enable the discharge conveyor to be folded in.

- The machine is on level ground and in a secure horizontal position.
- The discharge conveyor is in its operating position.
- The milling drum is not engaged.
- Loading and discharge conveyors are not being operated.

Operations required:

- Lower discharge conveyor until the front section of the belt frame touches the ground.  
If necessary, the front of the machine will have to be lowered via the traction unit legs.

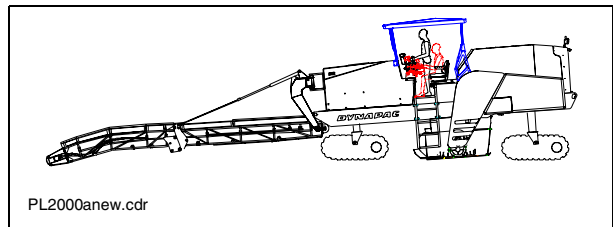

- Remove the interlock bolts (1) from both sides of the articulation range of the discharge conveyor.



Keep the bolts somewhere safe so that they are not lost.

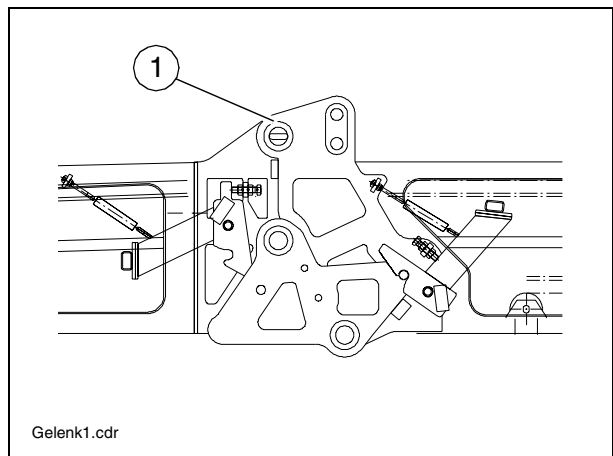

# D Operation

## 1 Safety regulations



Injury or death can result whenever the engine, travel drive, milling drum, conveyor or lifting units are engaged.

When operating the machine, therefore maintain strict compliance with the sections of these operating instructions and the safety specifications dealing with personal conduct.

Before starting up, ensure that no-one is working in or under the vehicle, and that no-one is in the immediate danger area!

- Do not start up the engine and do not use any of the controls if there is a notice specifically prohibiting their use!  
Unless otherwise specified, only operate the controls when the engine is running!
- Check thoroughly before starting the machine. Ensure that the machine status and position as well as the position of all safeguards, operating and adjustment fixtures permit the machine to be started safely.
- Sound the horn as a warning before starting the machine.









When the drive unit is operating, never step under the vehicle. Do not stand in the danger area of the vehicle unless absolutely necessary. Danger of death!



- While the equipment is operating, maintain a continuous check to ensure that no-one is in danger!
- Ensure that all guards and covers are in place and have been secured properly!
- Remedy any damage detected without delay! Operation is prohibited in the event of defects!
- Do not allow unauthorised people to travel on the machine.
- Clear all obstacles off the road surface and out of the working area!
- Always endeavour to select a position for the driver which places him/her on the nearside, i.e. away from road traffic! Lock the control panel and driver's seat in position.
- Maintain an adequate safety distance from overhangs, other equipment and other danger areas!
- On uneven ground, drive carefully to prevent slipping, tilting or overturning.



Always keep the vehicle under careful control. Never attempt to load it beyond its capacity limits!

| Pos. | Designation          | Short description  |
|------|----------------------|--|
| 6    | Start engine         | Actuate to start the engine<br> Starting the engine is only possible if no button is depressed and no control lever is actuated. All buttons are reset. |
| 7    | Stop engine          | Actuate to stop the engine.  |
| 8    | Engine speed setting | At the touch of a button a menu for engine speed adjustment appears on the LC display.   |

| Pos. | Designation                                | Short description   |
|------|--|---|
| 23   | Straight-ahead travel for rear drive units | Both drive units are swivelled out of their present steering positions into the straight-ahead position. The machine is then only steered by the front axle.<br> The function can only be activated with a delay (approx. 1 minute after program start).   |
| 24   | Steering of the rear drive units           | The drive units are swivelled to the right for as long as the button is depressed and remain in the position reached once the button is released.<br> If this function is engaged, steering mode is deactivated.   |
| 25   | Co-ordinated cornering mode                | Makes co-ordinated cornering possible. Front and rear steering of the vehicle can be engaged at the touch of a button.<br> Engaged functions are confirmed by LED.   |
| 26   | Speed indicator                            | LEDs tend to indicate the nominal travel speed of the vehicle.<br> The roadspeed is indicated on a display panel.   |
| 27   | Speed adjustment (-)                       | Reduces pre-selected nominal speed in the working gear  |
| 28   | Speed adjustment (+)                       | Increases the preselected nominal speed in the working gear.  |
| 29   | Travel drive fast / slow                   | Two switch positions can be selected:<br>- Hare: Transport speed<br>- Tortoise: Working speed<br> The engaged function is confirmed by LED.<br><br> The speed indicator changes from m/min to km/h.<br>When changing from operating speed to transport speed, levelling and the milling drum drive are automatically deactivated. |

| Pos. | Designation                   | Short description   |
|------|-------------------------------|---|
| 42   | Function key                  | <p>Press function key together with any of the following keys</p> <ul style="list-style-type: none"> <li>- 10</li> <li>- 12</li> <li>- 31</li> <li>- 37</li> <li>- 39</li> <li>- 40</li> <li>- 46</li> <li>- 55</li> </ul> <p>to call up a settings menu on the LC display in which the appropriate function can be altered or adjusted.</p> <p> The keys for adjustable functions are identified on the main operating panel by a double frame.</p> |
| 43   | Not in use                    |   |
| 44   | Extractor system (○) ON / OFF | <p>This engages the extractor system beside the planing section, the material transfer point between lower and discharge conveyors and the discharge area on the discharge conveyor.</p> <p> The engaged function is confirmed by LED.</p>   |
| 45   | Service mode                  | <p>This button can be pressed to raise the engine speed to a specified value.</p> <p> Only ever engage service mode for maintenance work or for repair work.</p>   |



During transport runs, the display shows actual road-speed in km/h (1). The display showing maximum achievable road-speed goes out at this time.

The trip and total in km displays also appear on both screens (2).

- Total: display showing the total distance travelled by the machine since delivery.
- Trip: display showing the total distance travelled in milling mode.

The trip display can be reset to zero by pressing the relevant function button (F7) twice or by pressing the zero button in the numerical keypad.

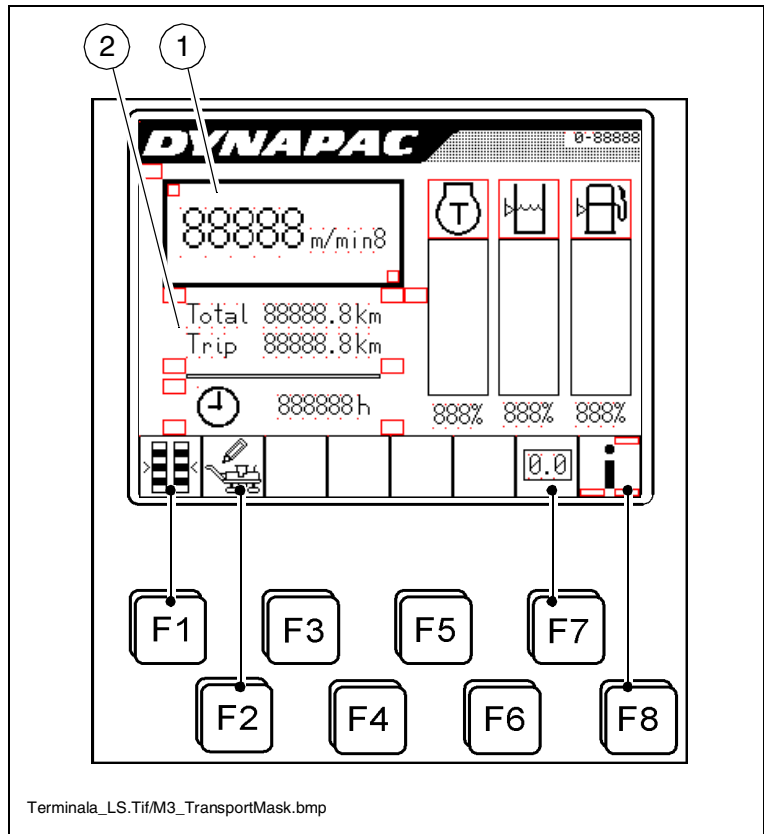

Further screens may be selected from this screen:

- (F1): Levelling screen
- (F2): Adjustment screen
- (F8): Info screen 1

CLICK HERE TO **DOWNLOAD** THE COMPLETE MANUAL

- Thank you very much for reading the preview of the manual.
- You can download the complete manual from: [www.heydownloads.com](http://www.heydownloads.com) by clicking the link below



- Please note: If there is no response to CLICKING the link, please download this PDF first and then click on it.

CLICK HERE TO **DOWNLOAD** THE COMPLETE MANUAL

## Engine warnings (I)

These warnings appear on screen automatically and indicate which fault has occurred.







The numeral (1) makes reference to the engine manufacturer's error list located in the Annex.

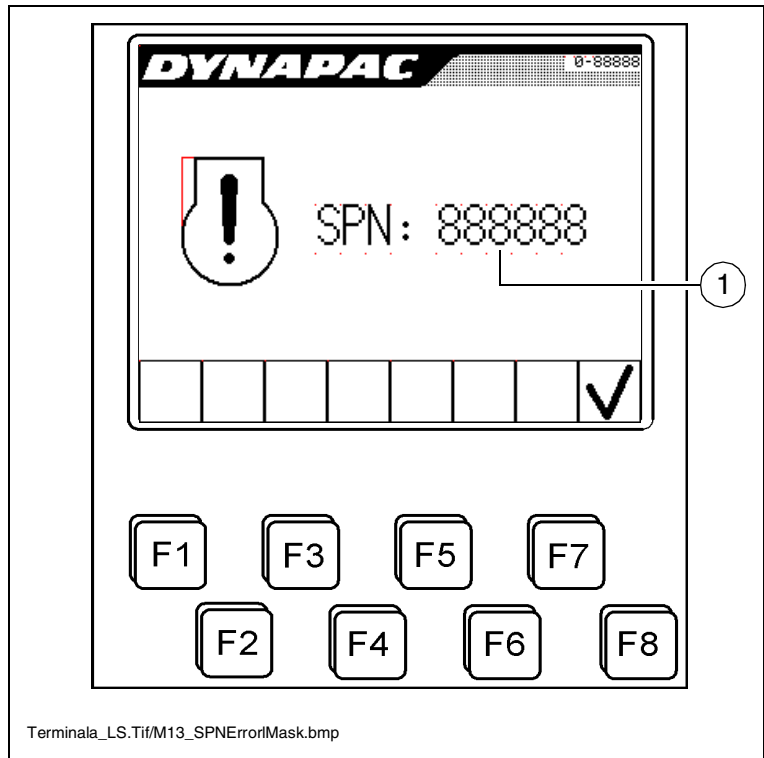





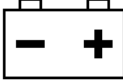

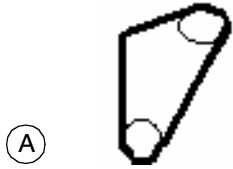
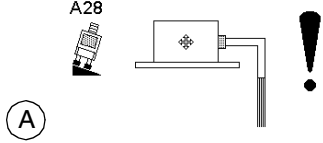
If a serious problem occurs the engine will be stopped automatically. In such case contact the Technical Service of the engine manufacturer and give details about the fault code.



| Designation            | Symbol  | Action   |
|------------------------|---|--|
| Engine speed           |    | Reduce engine speed<br>(possible coasting mode)  |
| Engine stop solenoid   |    | Check wiring on stop solenoid.<br>If necessary, call Service.  |
| Fuel temperature       |    | If necessary, top up fuel tank or carry out visual inspection for signs of leakage.<br>Check fuel return line. |
| Injector nozzles       |    |  Call Service!                |
| Battery (undervoltage) |  | Check generator, drive belts.<br>If necessary, call Service.   |

|  |   |
|--|---|
| <p>- A: Belt tensioner</p>   |  |
| <p>- A: Tilt sensor<br/>- Tilt outside range or measurements or<br/>- sensor defective</p> |  |

| Pos. | Designation                          | Short description   |
|------|--------------------------------------|---|
| 7    | Raising front right side of machine  | <p>While the button is being pressed, the front right traction unit is extended continuously until it reaches its limit position.</p> <p> When this function is active, levelling is disengaged automatically on the right side.</p>   |
| 8    | Lowering front right side of machine | <p>While the button is being pressed, the front right traction unit is retracted continuously until it reaches its limit position.</p> <p> When this function is active, levelling is disengaged automatically on the right side.</p>  |
| 9    | Raising rear of vehicle              | <p>While the button is being pressed, the rear traction units are extended continuously until they reach their limit position.</p>  |
| 10   | Lowering rear of vehicle             | <p>While the button is being pressed, the rear traction units are retracted continuously until they reach their limit position.</p>   |
| 11   | Raising the side board               | <p>While the button is being pressed, the side board (on the side on which the control panel is fitted) is raised continuously until it reaches its limited position. When the button is released, the side board automatically lowers back down to the lower limit position.</p> <p> Each control element only controls the function on the same side of the vehicle as itself.</p> <p> While the button is being pressed, the automatic leveller is set to „Standby“.</p> <p>With milling drum housing open:</p> <ul style="list-style-type: none"> <li>- 1. Press button: side board is raised.</li> <li>- 2. Press button: side board is lowered.</li> </ul> <p> Danger resulting from raised loads. Do not enter the danger area.</p> <p> If the engine is switched off, the side board slumps.</p> <p> If the milling drum housing is closed, the side board is lowered automatically.</p> |

## Battery's main switch

The battery's main switch can be found under the right-hand bottom lid. It separates the power supply from the battery for the main fuse.

The safeguard of the bottom lid can be opened using a square wrench.

- To deactivate the master switch, turn to the left and remove.
- Cover aperture with protective cap (2).



Do not lose the removed master switch because otherwise you will not be able to start the machine.



For the specifications governing all fuses, refer to Chapter „Maintenance“.

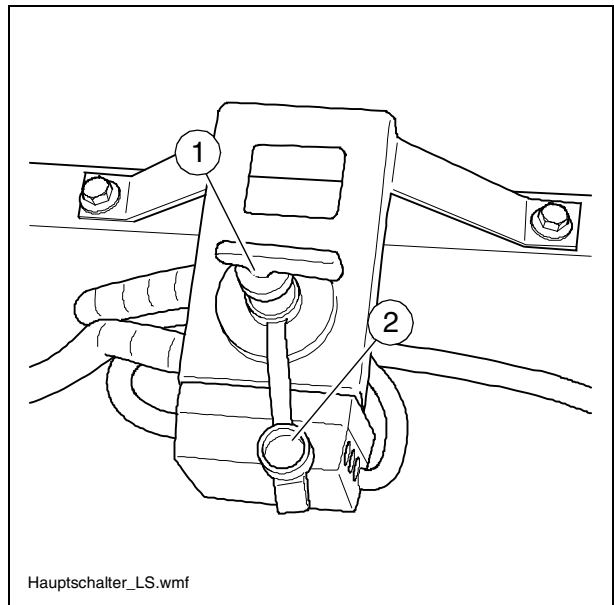

## Batteries

Behind the maintenance flap, one battery of the 24 volt system can be found on both the left and right behind the driver's seat.



For the specifications, refer to Chapter B „Technical data“.  
For maintenance, refer to Chapter „Maintenance“.



Only undertake external starting in accordance with the instructions (refer to Section „Starting machine, external starting (starting aid)“).

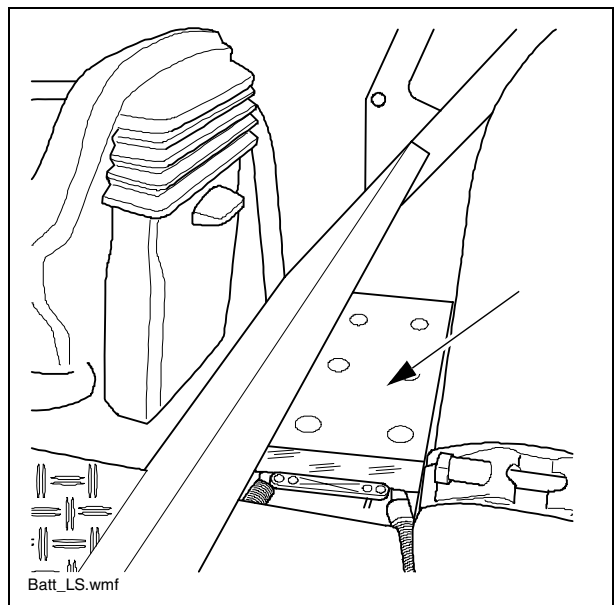

## 4.2 Controls, vehicle frame

### Filling pump for water tank

The filling pump for the water tank is located at the front left of the machine.

To fill the water tank:

- unscrew seal cap (1) (if necessary use wrench)
- attach suction line and tighten.
- start filling process by pressing switch (2).
- switch off filling pump as soon as the level of water required is reached in the water tank (monitor using the LCD display on the operating panel).

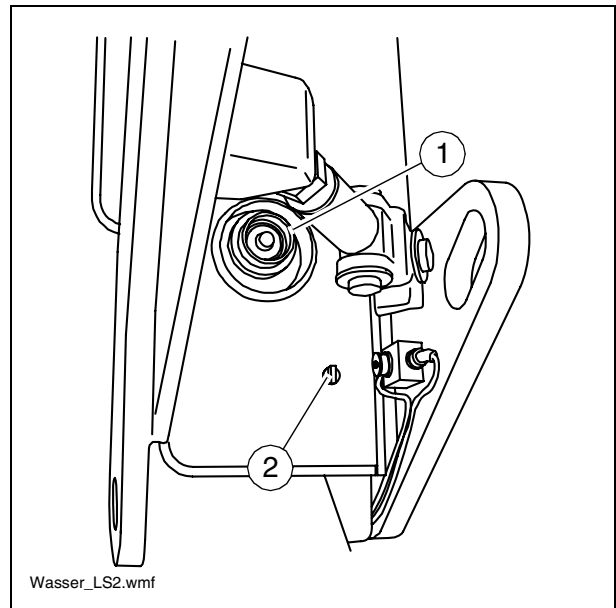

An overflow can be found on the underside of the machine. Excess water flows out through this if overfilled.



Ensure that the water is not too heavily contaminated because this may result in lengthy filter changes and cleaning work in the tank.

## Monitoring camera (○)

Four video cameras are fitted to the machine to observe the area of the milling track in front of the front drive unit, the area of the sliding shoe in front of the milling drum housing, the area of the scraper flap behind the milling drum housing and the area of the rear track during reverse.

If necessary, the cameras can be swivelled and individually set up.

- To swivel around axis (A), swivel the camera in the bracket up or down.
- To swivel around axis (B), unfasten the screws (1), swivel camera bracket and camera into the position required and re-tighten screws (1) correctly.

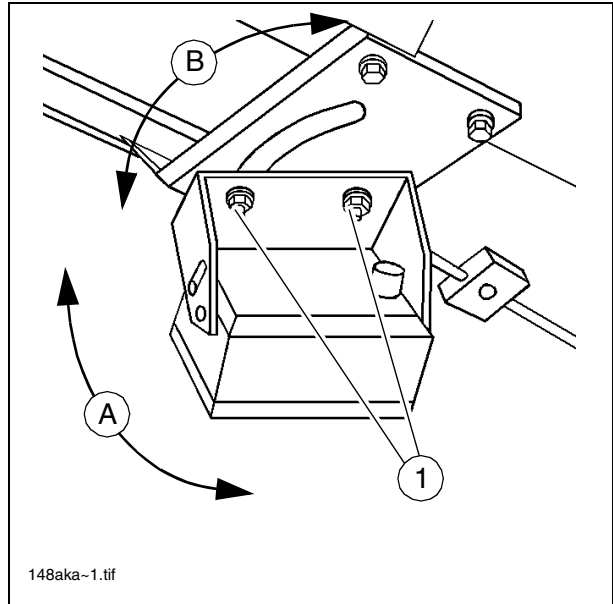

## Tank system (○)

To store diesel, e.g. from a barrel.

- Filler hose with stop cock (1), for filling at the tank neck.
- Intake hose (2)
- On/Off switch (3)



If the system is not being used, close the stop cock and seal the intake hose with a sealing plug.

Observe instructions for working with diesel!

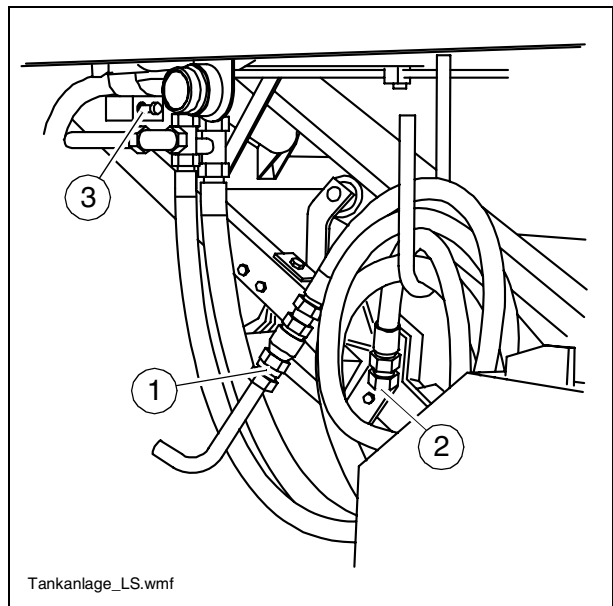

## 6.1 Liquid crystal display (1)

The display symbols have the following meanings:

| Symbol                                  | Meaning                         |
|---|---------------------------------|
| ARROWS<br>RAISE (12) /<br>LOWER (13)    | Controlled<br>controller output |
| Value without<br>prefix (14)            | Positive<br>display value       |
| Value with neg-<br>ative<br>prefix (15) | Negative<br>display value       |
| Bar dropping<br>to the right (16)       | Slope to the right              |
| Bar dropping<br>to the left (17)        | Slope to the left               |

### Activation message

A display test is conducted once the digital controller has been activated. During this test, all segments of the LC display and all function lamps are activated for approx. 2 seconds. Should symbols not appear on the display, please contact After-Sales Service.

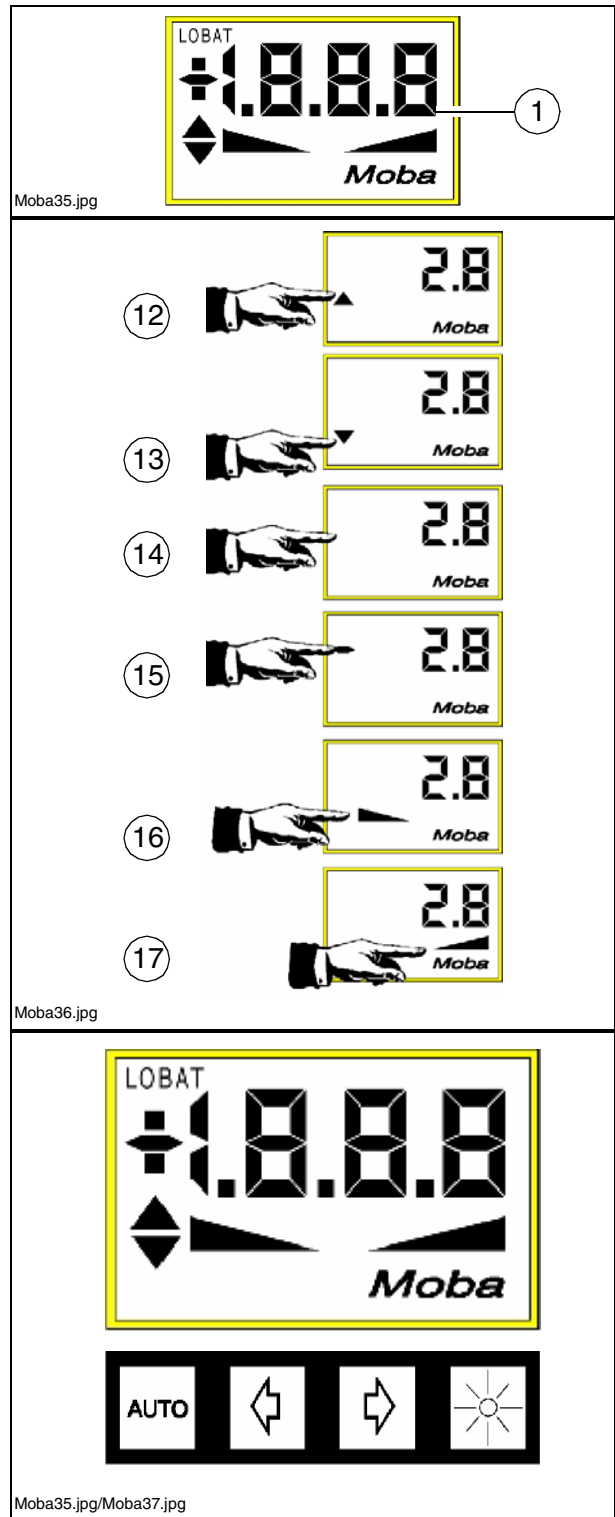

## SET button

- When using the Digi-Slope sensor, the SET button must always be used to confirm an actual slope value set in manual mode or preselected or existing in semi-automatic mode. This must be done before changing over into automatic mode so that this value is adopted as the nominal value.
- If when using the height sensors, the actual value or a pre-selected value is to be adopted as the nominal value following changeover into automatic mode, the SET button should only be briefly pressed, otherwise calibration to zero is conducted (refer to zero setting)

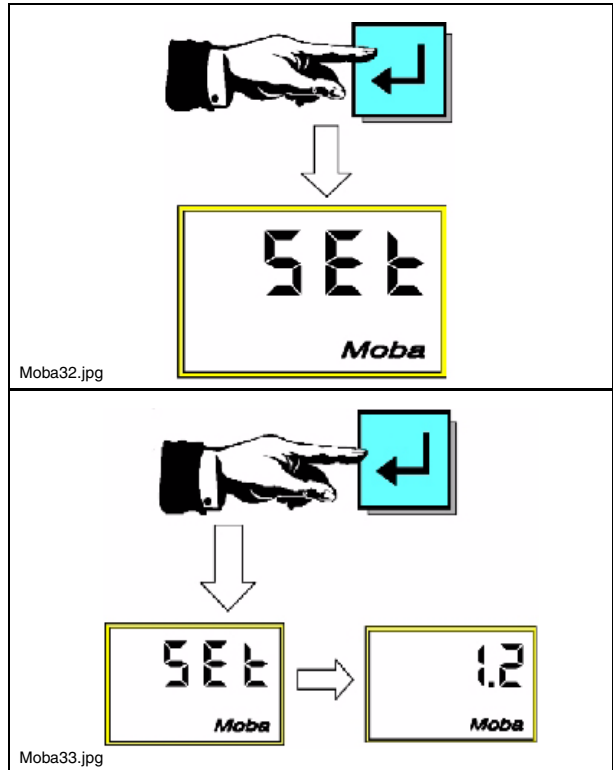

## Levelling function button and emergency stop button on rear lower control panel



Unwanted operations triggered when setting cutting values, such as uncontrolled extension or retraction of the front traction units supports can be stopped at any time by pressing the levelling function button (1) to move it from "AUTO" to "0" or by pressing the emergency stop button (2).

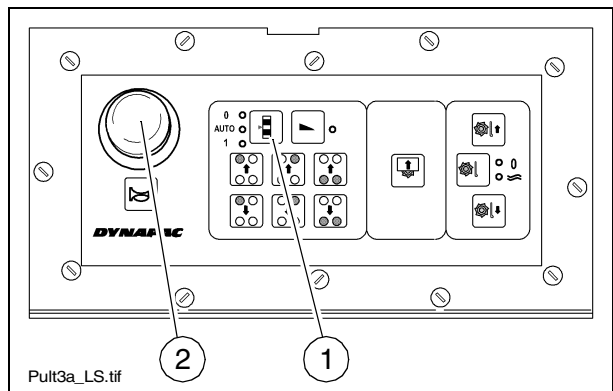

**Example:**

The controller value displayed is corrected to the value measured using the spirit level as follows:

- The A/M button is used to change over to manual mode, the „Auto“ function lamp is off.
- The display shows the actual value.  
The display shows the actual value.
- Press and hold down the input key. „SET“ appears on the display, then the display changes again to the actual value.
- The input key remains depressed and the actual value is corrected to the value required (example 2.3) using the UP/ DOWN buttons.

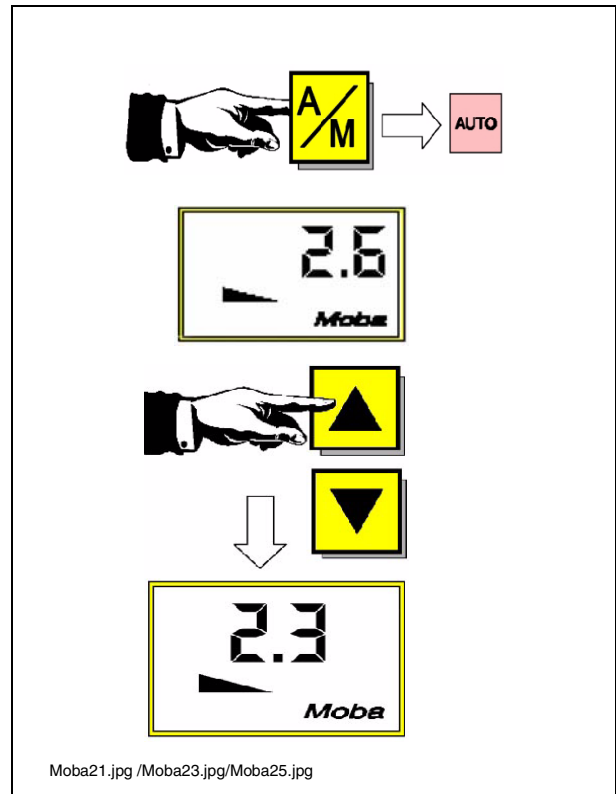

## Checklist for machine operator

Once the maintenance and checking work listed in the maintenance manual has been conducted at the specified intervals, the inspections and control work listed in the following list should also be noted and conducted.

This work is used to assess the machine status and to assure perfect operations as well as personal safety.

If permitted by the operations in question, the checks should be conducted before, during and after use.

Any defects found should be rectified immediately in compliance with the safety regulations.

| Check!   | How?  |
|--|---|
| Emergency-stop button <ul style="list-style-type: none"> <li>- on main control panel</li> <li>- on the side control units</li> </ul> | Check with engine running:<br>Engine must shut down immediately after actuation.<br>The button engages and must be pulled out so that the engine can be started again.<br>Warning signal and warning information via display indicator  |
| Horn <ul style="list-style-type: none"> <li>- on main control panel</li> <li>- on the side control units</li> </ul>                  | Briefly press horn knob.<br>Horn signal must sound.   |
| Reverse travel warning device  | Check with engine running.<br>Acoustic signal must sound during reverse travel.   |
| Lighting <ul style="list-style-type: none"> <li>- Operating headlight</li> <li>- Rotary beacons</li> <li>- Hazard flasher</li> </ul> | Lights must function,<br>keep headlight glass clean.  |
| Steering system  | Check with engine running:<br>Machine in straight-ahead travel position, steering system responds in sync with the steering lever adjustment, uniform steering locks in all steering variants (when in co-ordinated steering mode and in crab steering mode, the rear axle does however respond with a slight delay).<br>Precise straight-ahead position of front and rear axle once the appropriate function keys have been pressed. |

Activate the following functions on the main operating panel:

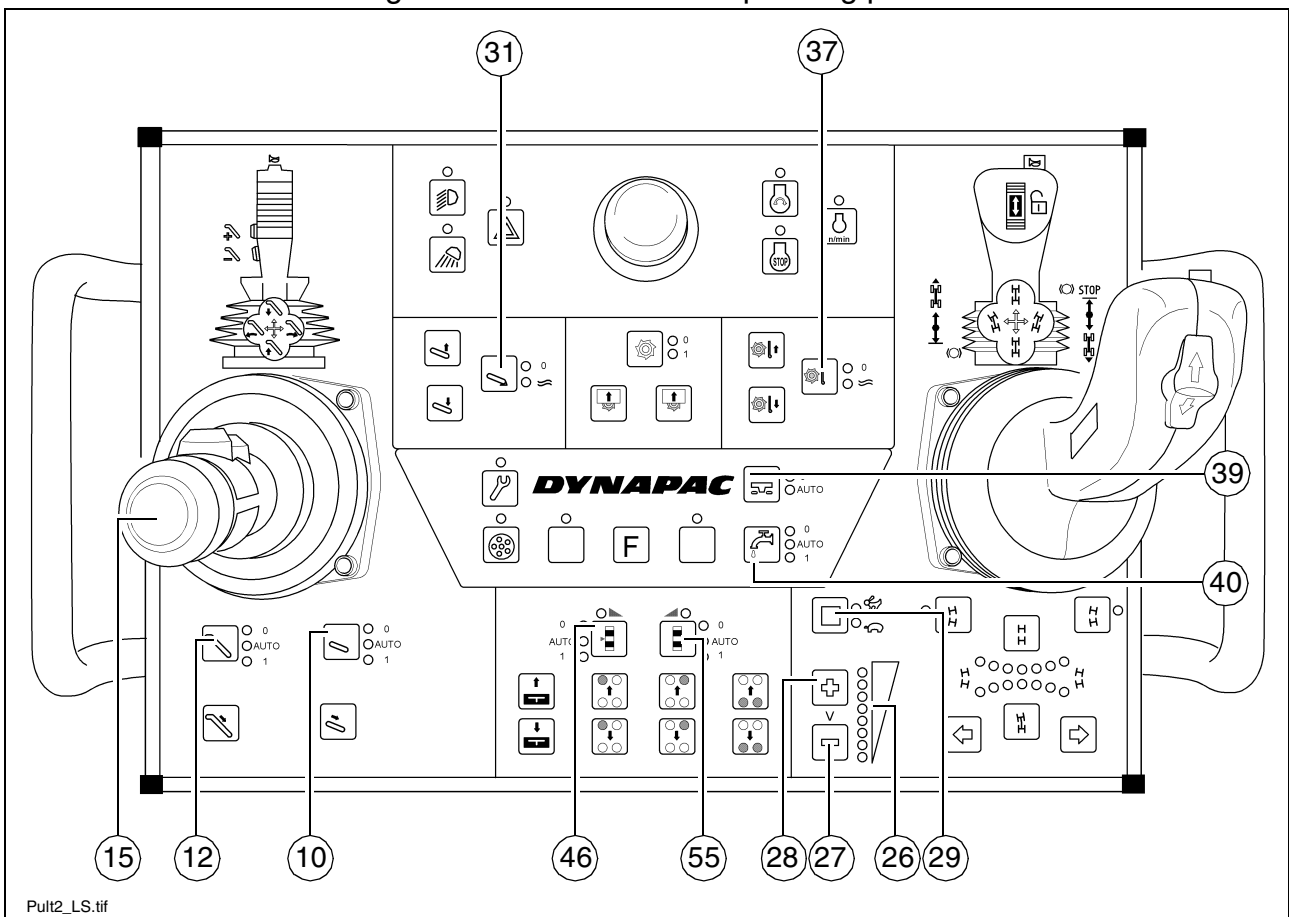

Pult2\_LS.tif

| Item.  | Button                               | Position  |
|--------|--------------------------------------|---|
| 29     | Transport/working gear               | Working gear (tortoise mode)                        |
| 27/28  | Set operating speed to zero          | Light diodes (26) are off                           |
| 39     | Milling drum ON / OFF                | Milling drum drive ON                               |
| 37     | Selector switch for moldboard        | Floating position                                   |
| 31     | Selector switch for sliding shoe     | Floating position                                   |
| 12     | Discharge conveyor mode              | AUTO  |
| 15     | Control lever for discharge conveyor | Position discharge conveyor for the loading process |
| 10     | Lower conveyor mode                  | AUTO  |
| 40     | Water pump ON / OFF                  | AUTO  |
| 46     | Levelling function, left             | AUTO  |
| 55     | Levelling function, right            | AUTO  |
| 39 (○) | Set-up button                        | Function activated                                  |



The automatic function of the scraper, sliding shoe, upper and lower conveyor, water spray equipment can also be activated or deactivated from the lower control panels.

CLICK HERE TO **DOWNLOAD** THE COMPLETE MANUAL

- Thank you very much for reading the preview of the manual.
- You can download the complete manual from: [www.heydownloads.com](http://www.heydownloads.com) by clicking the link below



- Please note: If there is no response to CLICKING the link, please download this PDF first and then click on it.

CLICK HERE TO **DOWNLOAD** THE COMPLETE MANUAL