

ETV 110-112

07.14

Operating instructions

GB

51317663

03.16

ETV 110
ETV 112

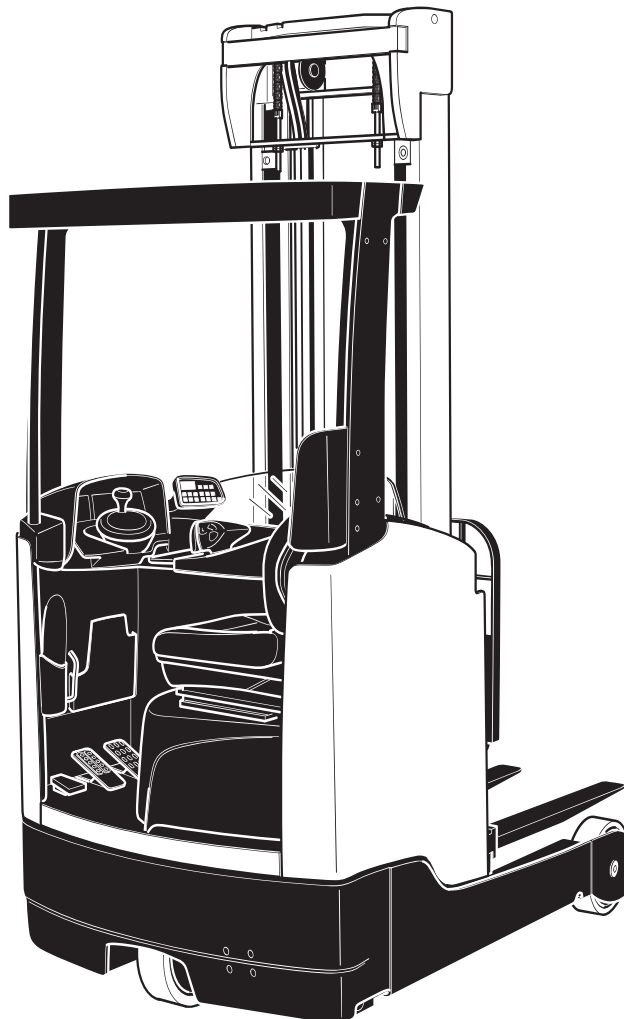

CLICK HERE TO **DOWNLOAD** THE COMPLETE MANUAL

- Thank you very much for reading the preview of the manual.
- You can download the complete manual from: www.heydownloads.com by clicking the link below



- Please note: If there is no response to CLICKING the link, please download this PDF first and then click on it.

CLICK HERE TO **DOWNLOAD** THE COMPLETE MANUAL

A Correct Use and Application

1 General

The truck must be used, operated and serviced in accordance with the present instructions. All other types of use are beyond its scope of application and may result in damage to personnel, the industrial truck or property.

2 Correct application

NOTE

The maximum load and load distance are indicated on the capacity plate and must not be exceeded.

The load must rest on the load handler or be lifted by an attachment approved by the manufacturer.

The load must be fully raised, see page 98.

CAUTION!

Loss of stability can cause accidents

Extended mast sections when the truck is travelling with or without load will reduce the truck's stability.

► Always travel with the mast holder retracted, the mast tilted back and the load handler lowered.

The following operations are permitted:

- Lifting and lowering loads.
- Transporting lowered loads.

The following operations are prohibited:

- Travelling with a raised load (>30 cm).
- Transporting hanging loads. If the truck is to be operated with hanging loads, proof of sufficient safety distance under local operating conditions must be obtained from a specialist assessor.
- Carrying and lifting passengers.
- Pushing or pulling load units.

Operator position

The operator position is ergonomically designed with ample legroom. To achieve the correct seated position, the driver's seat and steering head can be adjusted by the driver. The accelerator pedal and brake pedal (19, 20) are of "automotive" design.

Curve Control

Automatic speed reduction for cornering. Curve Control limits the speed and acceleration when cornering. This reduces the risk of oscillations or tipovers.

Drive system

The entire drive unit is bolted onto the chassis of the truck. A fixed AC threephase motor controls the drive wheel (23) via a bevel spur gearbox.

The electronic traction current controller ensures a smooth drive motor speed and as a result smooth start-up, powerful acceleration and electronically controlled braking with energy recovery.

Controls and displays

Controls and displays are clearly arranged in the driver's cab. The logically designed SOLO-PILOT (11) enables single handed operation of travel direction, lift/lowering, forward / reverse reach, mast tilt, sideshift left or right and auxiliary hydraulics HF5 (○).

Displays

Control and display unit (13) with residual time display, battery discharge indicator, lift and travel profile settings and steer angle mode display. The battery discharge indicator and hourmeter are combined on the control and display unit (13). The discharge indicator is designed as a monitor which cuts out lifting when the battery is discharged, in order to avoid depletion.

6.9 Conditions of use

Ambient temperature

– operating at -30°C to +40°C

- Special equipment and authorisation are required if the truck is to be used continually in conditions of extreme temperature or condensing air humidity fluctuations.
- Special equipment and authorisation are required if the truck is to be constantly used in 0°C.
- The permissible operating conditions change if the truck is equipped with a lithium-ion battery (○), see the manufacturer's operating instructions.

6.10 Electrical Requirements

The manufacturer certifies compliance with the requirements for the design and manufacture of electrical equipment, according to EN 1175 "Industrial Truck Safety - Electrical Requirements", provided the truck is used according to its purpose.

2.1 Lifting the truck by crane

CAUTION!

The mast can get damaged

- ▶ Loading by crane is only intended for the initial transport before the truck is used for the first time.
 - ▶ Loading must be carried out by specially trained staff in accordance with recommendations contained in Guidelines VDI 2700 and VDI 2703
-

DANGER!

Crane slings can tear, resulting in accidents

- ▶ Only use crane lifting gear with sufficient capacity.
 - ▶ Loading weight = Net weight of truck (+ battery weight for electric trucks).
 - ▶ The mast must be tilted back fully.
 - ▶ The crane lifting gear on the mast must have a minimum clear length of 2 m.
 - ▶ Crane slings should be fastened in such a way that they do not come into contact with any attachments or the overhead guard when lifting.
 - ▶ Do not stand under a swaying load.
 - ▶ The truck should only be handled by people who are trained in using lifting slings and tools.
 - ▶ Wear safety shoes when lifting the truck by crane.
 - ▶ Do not walk into or stand in a hazardous area.
 - ▶ Always attach the crane lifting gear to the prescribed strap points and prevent them from slipping.
-

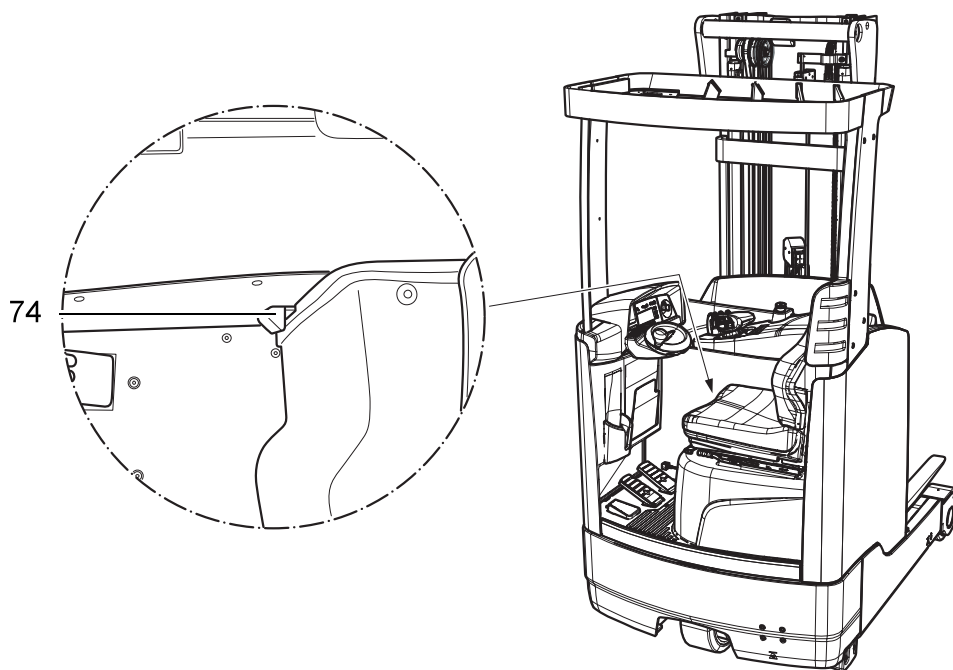
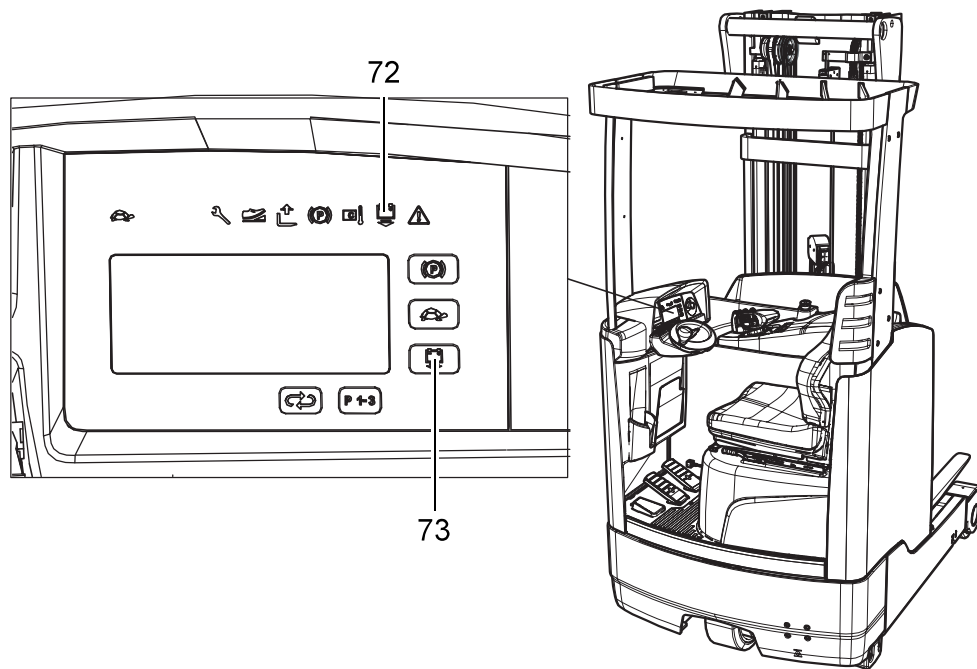

Installing the battery with the battery trolley (○)

Requirements

- Battery removed.
- Battery cover removed.





Tools and Material Required

- Battery trolley

Procedure

- Bring the battery trolley with the battery up to the truck.
- Push the battery off the trolley into the battery compartment.
- Insert the battery stop (77).
- Tighten the retaining screw (79) and jam nut (78) or handle (80) on the battery stop (77).
- Attach the battery connector to the truck connector.
- Fit the battery cover.

The battery is now assembled.

Item		Description	Function
102		Travel-speed display	Shows the speed setting (drive direction) for current profile (in bars from 1 to 5).
103		Lift-speed display	Shows the speed setting (lift) for current profile (in bars from 1 to 5).
104		Time / residual-time / load-weight display	Display <ul style="list-style-type: none"> – Time display (hours:minutes) – Battery residual time – Load weight
105		Parking-brake button	Parking-brake activation/deactivation button.
106		Residual-time display	Displays the residual run time with on-board battery (hours:minutes)
107		Charge-status display	Shows the battery-charge status.
108		Slow travel	Travel-mode setting button.
109		Discharge indicator	Shows the battery-charge status.
110		Display Information and event-message display	Display <ul style="list-style-type: none"> – Load weight – Lift height – Service hours – Event messages
111		Steering angle	Displays the steering angle in 30° increments.
112		Direction display	Displays travel direction and steer mode <ul style="list-style-type: none"> – Semi-circle = 180° – Circle = 360° endless steering
113		Shift key	Display-change button.
114		Performance-setting button	Button to select performance level 1, 2 or 3.
115		Lift-height load centre distance	Displays the load centre distance or the lift height.
116		Performance setting number	Displays the performance setting number (1,2 or 3).

3.3.2 Adjusting the comfort seat (○)

Setting the driver's weight

NOTE

Incorrectly adjusted seat cushioning can damage your health

To achieve optimal seat cushioning, the driver's seat must be adjusted according to the driver's weight.

Set the driver's weight when the seat is occupied.

- ▶ Hold the weight adjustment lever only by the recess; do not reach through underneath the weight adjustment lever.

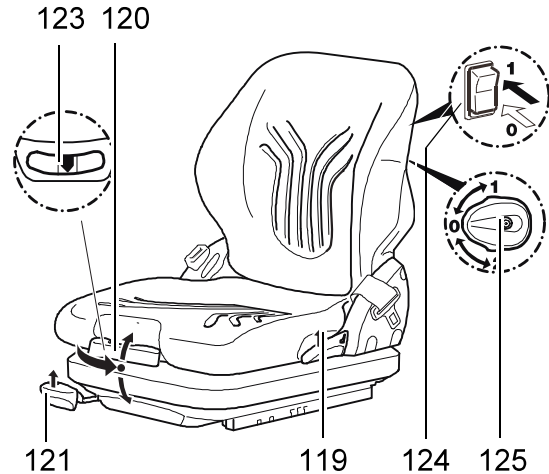

Procedure

- Fold out the weight adjustment lever (120) as far as it will go in the arrow direction.
- Move the weight adjustment lever (120) up and down to set the seat to a higher weight.
- Move the weight adjustment lever (120) down and up to set the seat to a lower weight.



The driver's weight is correctly set when the arrow is in the middle of the display window (123). The minimum or maximum weight setting is reached when you can feel a return stroke on the lever.

- After setting the weight, fully fold back in the weight adjustment lever (120).

The driver's weight is now set.

Fully automatic weight adjustment (○)

A compressor in the driver's seat adjusts the seat position according to the weight of the driver.

Adjusting the backrest

Procedure

- Sit on the driver's seat.
- Pull the lever (119) to adjust the backrest.
- Adjust the backrest tilt.
- Release the lever (119) again. The backrest is locked.

The backrest is now set.

CLICK HERE TO **DOWNLOAD** THE COMPLETE MANUAL

- Thank you very much for reading the preview of the manual.
- You can download the complete manual from: www.heydownloads.com by clicking the link below



- Please note: If there is no response to CLICKING the link, please download this PDF first and then click on it.

CLICK HERE TO **DOWNLOAD** THE COMPLETE MANUAL

4.5 Travel

WARNING!

Improper travel can result in accidents

- ▶ Do not get up from the driver's seat during travel.
- ▶ Make sure that the travel area is clear.
- ▶ Adapt the travel speed to the conditions of the route, the work area and the load.
- ▶ Tilt the mast back and raise the fork carriage approx. 200 mm.
- ▶ Make sure you have enough visibility when reversing.

CAUTION!

Loss of stability can cause accidents

Extended mast sections when the truck is travelling with or without load will reduce the truck's stability.

- ▶ Always travel with the mast holder retracted, the mast tilted back and the load handler lowered.



Each time the truck is started the operation of the emergency stop safety switch is tested. The fault display is shown on the display unit for the duration of the safety check. Travel and steering are only enabled if the condition is satisfactory.

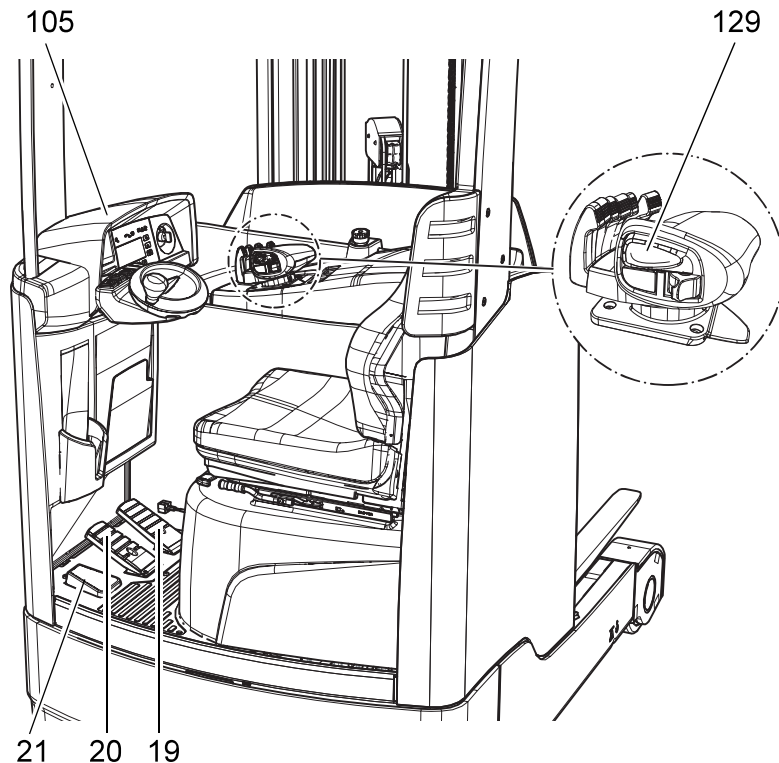

⚠ CAUTION!

Risk of trapping from moving parts!

When the mast holder moves you can get trapped between the mast and battery tray.

▶ Do not reach between the mast and the battery tray.

Moving the mast holder with the SOLO-PILOT

Procedure

- Push the SOLO-PILOT (75) in direction (T) to extend the mast holder forward.
- Pull the SOLO-PILOT (75) in direction (U) to retract it.

The mast holder is now extended.

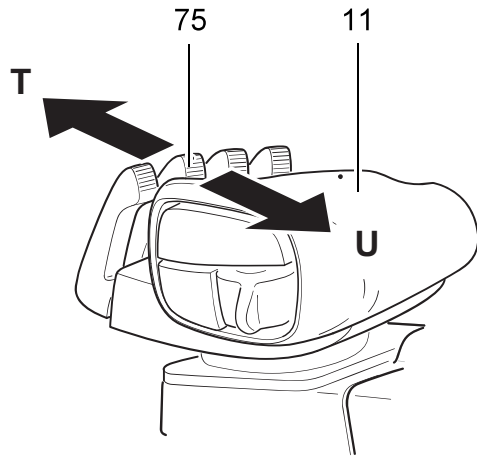

Moving the mast holder with the MULTI-PILOT

Procedure

- Push the MULTI-PILOT (81) in direction (T) to extend the mast holder forward.
- Pull the MULTI-PILOT (81) in direction (U) to retract it.

The mast holder is now extended.

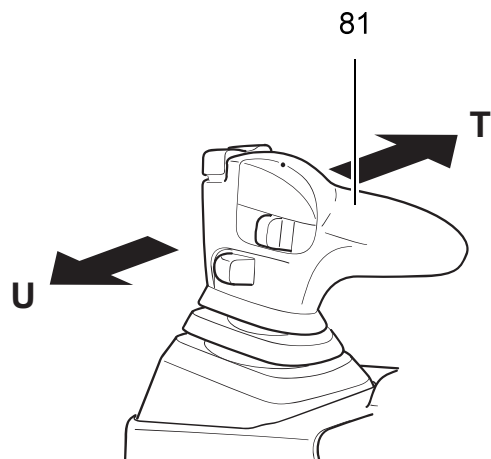

4.12 Emergency lowering



The load handler can be lowered manually if a fault occurs in the hydraulic controller.

WARNING!

Lowering the mast can result in injuries

- ▶ Instruct other people to move out of the hazardous area of the truck during emergency lowering.
- ▶ Never stand underneath a raised load handler.
- ▶ Apply the emergency lowering valve from a position next to the truck.
- ▶ Emergency lowering of the mast cannot be applied when the load handler is in the rack.
- ▶ Report any defects immediately to your supervisor.
- ▶ Tag out and decommission a faulty lift truck.
- ▶ Only return the truck to service when you have identified and rectified the fault.

Mast emergency lowering

Requirements

- Load handler is not in the rack.
- Turn the Emergency Disconnect switch and key switch off.
- Disconnect the battery.

Procedure

- Release the emergency lowering valve (139) underneath the truck by max. 1/2 a turn anti-clockwise with the 4 mm Allen screw.
- The mast and load handler will lower slowly. If necessary the lowering speed can be reduced by turning clockwise or the load can be stopped.
- When the load has been lowered, close the emergency lowering valve with a torque of 2,5 Nm.

The mast is now lowered.

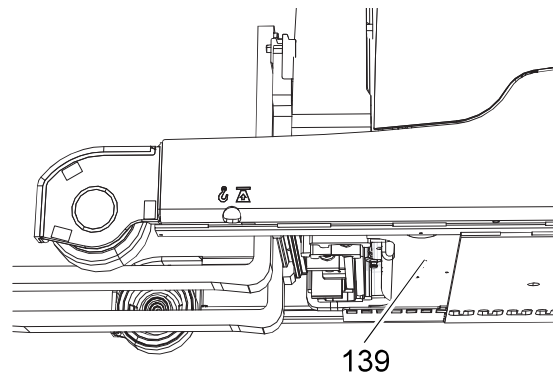

WARNING!

Only return the truck to service when you have identified and rectified the fault.

The ○ key indicates the follow operational statuses via a red / green LED (147):

- Code lock function (commissioning the truck).
- Setting and changing parameters.

SET key

When you change the parameters the SET key (146) acts as a confirmation key.

6.1.8 Delete all user codes,

Requirements

– To prepare the truck for operation, see page 122.

Procedure

- Press the O key (148).
- Enter the valid master code with the digit keys.
When you enter the valid master code the LED (147) flashes green.
- Enter the parameters 0-0-4 with the digit keys.
- Confirm with the SET key (146).
The LEDs (145,147) flash green.
- Enter the code 3-2-6-5 with the digit keys.
- Confirm with the SET key (146).
Wait until the LED (147) flashes green. All user codes are deleted.
- Press the O key (148).
The truck is switched off and the LED (147) is lit red.
- Check that the user codes have been deleted:
 - Switch on the truck with a previous user code, see page 122.
After entering the user code the LED (147) flashes red and the truck remains switched off.
 - Press the O key (148).
The truck remains switched off and the LED (147) is lit red.

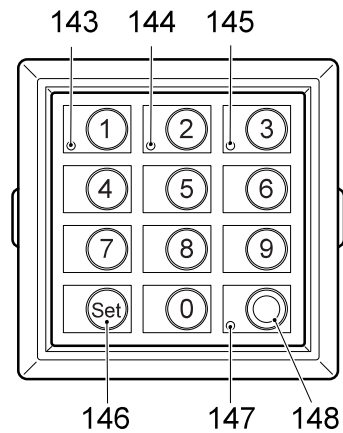

6.7 Height cut out

The height cut out feature is an electrical height restriction to limit the maximum lift height in the mast lift range. The cut out height is defined by a magnet (161). If the switch (160) and magnet (161) are at the same height, the pump motor cuts out and lifting is disabled.

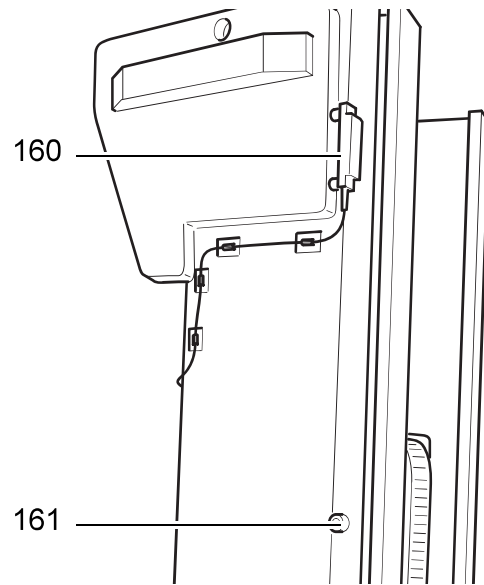

Overriding the lift limit cutout without the override button

Procedure

- Set the SOLO-PILOT lever (134) or MULTI-PILOT (81) to neutral.
- Pull the SOLO-PILOT lever (134) or MULTI-PILOT (81) in direction H, see page 98

*The lift limit cutout is now overridden.
Lifting can now be performed at reduced speed.*

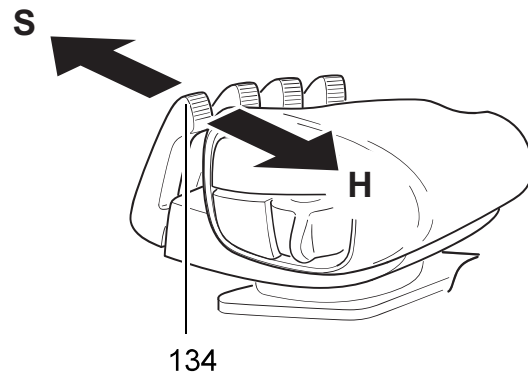

Overriding the lift limit cutout with the override button

Procedure

- Press the lift limit override button (83) while simultaneously pulling the SOLO-PILOT lever (134) or MULTI-PILOT (81) in direction H, see page 98.

*The lift limit cutout is now overridden.
Lifting can now be performed at reduced speed.*

F Industrial Truck Maintenance

1 Operational Safety and Environmental Protection

WARNING!

Risk of accidents and damage to components

Any modification to the truck, in particular the safety mechanisms, is prohibited. Do not alter the truck's operating speeds under any circumstances.
Do not bond the front window with adhesive.

Exception: Operating companies should only make changes or have changes made to powered industrial trucks if the manufacturer is no longer operating in the field and there is no successor to the business; operating companies must however:

- Ensure that the changes to be made are planned, tested and performed by a specialist engineer in industrial trucks taking safety into account.
- Keep permanent graphic records of the plans, tests and completion of the changes
- Carry out and have authorised the respective changes to the capacity data plates, decals and stickers as well as the operator and service manuals.
- Attach permanent and clearly visible marking to the truck indicating the types of changes made, the date of the changes and the name and address of the organisation responsible for the work.

NOTE

Only original spare parts are subject to the manufacturer's quality control. To ensure safe and reliable operation, use only the manufacturer's spare parts.

For safety reasons, only components which have been specially agreed by the manufacturer for this truck may be installed near the computer, controllers and wire guidance sensors (antennae). These components (computers, controllers, wire guidance sensors (antennae)) must therefore not be replaced by similar components from other trucks of the same series.



On completion of inspection and service work, carry out the operations listed in the "Recommissioning the truck after cleaning or maintenance work" section (see page 171).

4.2 Lifting and jacking up the truck safely

WARNING!

A truck tipover can cause accidents

In order to raise the truck, use only suitable lifting gear at the points specially provided for this purpose.

- ▶ Note the weight of the truck on the data plate.
 - ▶ Always use a jack with sufficient capacity.
 - ▶ Raise the unladen truck on a level surface.
 - ▶ When raising the truck, take appropriate measures to prevent it from slipping or tipping over (e.g. wedges, wooden blocks).
-

Raising and jacking up the truck securely

Requirements

- Prepare the truck for maintenance and repairs (see page 160).

Tools and Material Required

- Jack
- Hard wooden blocks

Procedure

- Place the jack against the contact point.
-  Jack contact point, see page 36.
- Raise the truck.
 - Support the truck with hard wooden blocks.
 - Remove the jack.

The truck is now securely raised and jacked up.

5.3 Restoring the truck to service after decommissioning

Procedure

- Thoroughly clean the truck, see page 152.
- Lubricate the truck according to the lubrication schedule, see page 158.
- Clean the battery, grease the terminal screws and connect the battery.
- Charge the battery, see page 54.
- Start up the truck, see page 74.

CLICK HERE TO **DOWNLOAD** THE COMPLETE MANUAL

- Thank you very much for reading the preview of the manual.
- You can download the complete manual from: www.heydownloads.com by clicking the link below



- Please note: If there is no response to CLICKING the link, please download this PDF first and then click on it.

CLICK HERE TO **DOWNLOAD** THE COMPLETE MANUAL