

Operating Instructions

CE

Hydraulic Excavator

RH 120E No.

Bucyrus HEX GmbH



CLICK HERE TO **DOWNLOAD** THE COMPLETE MANUAL

- Thank you very much for reading the preview of the manual.
- You can download the complete manual from: www.heydownloads.com by clicking the link below



- Please note: If there is no response to CLICKING the link, please download this PDF first and then click on it.

CLICK HERE TO **DOWNLOAD** THE COMPLETE MANUAL

1 INTRODUCTION

2804051

	Operating instructions	Target group
Part 1	INTRODUCTION FUNDAMENTAL SAFETY INSTRUCTIONS	Operating personnel + Inspection and servicing personnel + Repair personnel
Part 2	OPERATION	Operating personnel The operating personnel must have know-how relevant to the operation and the application of this or comparable machines.
Part 3	INSPECTION AND SERVICING	Inspection and servicing personnel The inspection and servicing personnel must have know-how relevant to the inspection and servicing of this or comparable machines.
Part 4	REPAIR WORK	Repair personnel The repair personnel must have know-how and experience relevant to the repair of this or comparable machines.
Part 5	ANNEX	Operating personnel + Inspection and servicing personnel + Repair personnel
Part 6	INDEX	Operating personnel + Inspection and servicing personnel + Repair personnel



Gas, dust, steam and smoke

Always start and operate the engine in a well-ventilated area;

If in an enclosed area, vent the exhaust to the outside;

Do not modify or tamper with the exhaust system

Diesel engine exhaust and some of its constituents are known to cause cancer, birth defects, and other reproductive harm

Operate fuel-operated heating systems only on adequately ventilated premises. Before starting the machine on enclosed premises, make sure that there is sufficient ventilation.

Observe the regulations in force at the respective site.

Carry out welding, flame-cutting and grinding work on the machine only if this has been expressly authorized, as there may be a risk of explosion and fire.

Before carrying out welding, flame-cutting and grinding operations, clean the machine and its surroundings from dust and other inflammable substances and make sure that the premises are adequately ventilated (risk of explosion).

Hydraulic equipment

Check all lines, hoses and screwed connections regularly for leaks and obvious damage. Repair damage immediately. Splashed oil may cause injury and fire.

Depressurize all system sections and pressure pipes (hydraulic system) to be removed in accordance with the specific instructions for the unit concerned before carrying out any repair work.

Hydraulic lines must be laid and fitted properly. Ensure that no connections are interchanged. The fittings, lengths and quality of the hoses must comply with the technical requirements.

Noise

During operation, all sound baffles of the machine must be closed.

Always wear the prescribed ear protectors.

Oil, grease and other chemical substances

When handling oil, grease or other chemical substances, observe the product-related safety regulations (see safety specifications).

Be careful when handling hot consumables (risk of burning or scalding).

Transporting and recommissioning

The machine must be loaded and transported only in accordance with the operating instructions.

Use only appropriate means of transport and lifting gear of adequate capacity.

The recommissioning procedure must be strictly in accordance with the operating instructions.

Excavator layout

Fig. 2-1:

Undercarriage

- 1 - Track drive
- 2 – Idler
- 3 - Track roller
- 4 - support roller
- 5 - Crawler track
- 6 - Track tensioner
- 7 - Slewing ring
- 8 - Ladder

Superstructure

- 10 - Engine
- 11 - Radiator (engine cooling liquid)
- 11 - Reservoir (cooling liquid)
- 13 - Air-intake system
- 14 - Exhaust system
- 15 - Fuel tank
- 16 - Hydraulic oil reservoir
- 17 - Hydraulic oil cooler
- 18 - Engine oil reservoir (optional)
- 19 - Pump transfer gearbox
- 20 - Working pump
- 21 - Cooling oil pump
- 22 - Servo system pump 35 bars
- 23 - Servo system pump 60 bars
- 24 - Gearbox circulating pump
- 25 - Slewing pump
- 26 - Fan drive pump (cooler, hydraulic oil)
- 27 - Fan drive pump (radiator, engine cooling liquid)
- 28 - Air compressor drive (air conditioning system)
- 29 – Slewing gear
- 30 – Travel block and rotor
- 31 – Driver` cab
- 32 – Control stand with BCS
- 33 – Control cabinet
- 34 – Air conditioner (optional)

- 35 – Fire-extinguisher
- 36 – Control cabinet with battery main switch
- 37 - Batteries
- 38 - Service-station, (tanklift)
- 39 - Ladder
- 40 - Ladder
- 41 - Grease container for central lubricating system
- 42 - Tool cabinet (optional)
- 43 - Counterweight
- 44 - On-board crane (optional)
- 45 - Drive unit (onboard crane, optional)

Loading bucket

- 51 – Boom
- 52 - TriPower linkage
- 53 – Stick
- 54 - Bottom-dump bucket
- 55 - Boom cylinder
- 56 - Stick cylinder
- 57 - Tipping cylinder
- 58 - Bottom-dump cylinder
- 64 - Control valves
- 65 - Quick-action valve

Backhoe bucket

- 53 - Stick
- 55 - Boom cylinder
- 56 - Stick cylinder
- 59 - Monoblock boom
- 60 - Backhoe bucket
- 61 - Backhoe cylinder
- 62 - Toggle link
- 63 - Toggle lever
- 64 - Control valves
- 65 - Quick-action valve

Fire extinguisher

The excavator is equipped with two fire extinguishers (arrow Fig. 2-19:)

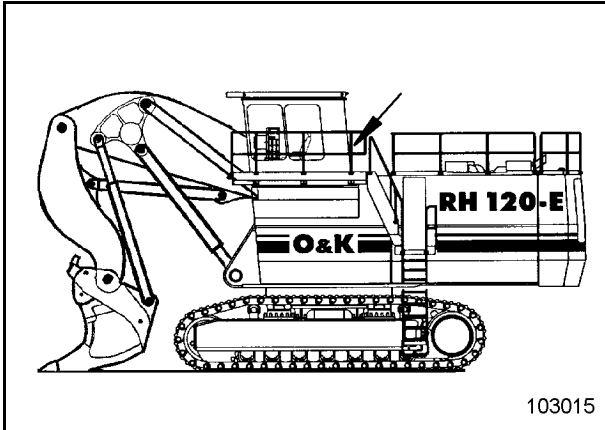

Fig. 2-19:

The excavator driver and the maintenance personnel must inform themselves about how to handle the fire-extinguisher in order to be able to act fast and efficiently in case of beginning fires. Such instruction should be given by a qualified instructor.

Fire extinguisher (option)

The fire extinguishers can be installed, for instance, at the places indicated by the arrows (Fig. 2-20:).

The excavator driver and the maintenance personnel must inform themselves about how to handle the fire-extinguisher in order to be able to act fast and efficiently in case of beginning fires. Such instruction should be given by a qualified instructor.

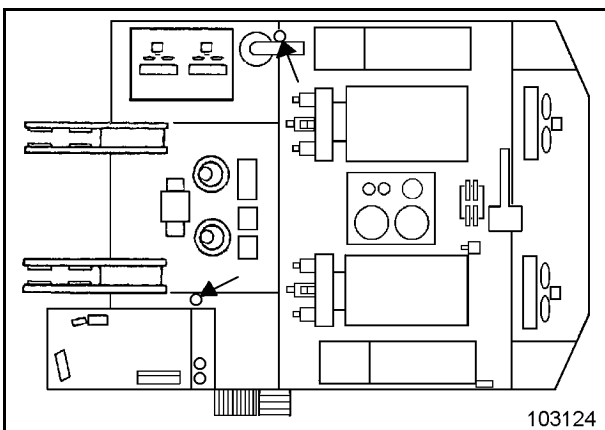

Fig. 2-20:

Extinguishing agent

Each fire-extinguisher is filled with 12 kg Glutex. This extinguishing agent is used for fighting fires of classes A, B and C. Fires are extinguished fast, perfectly and without residues.

Handling

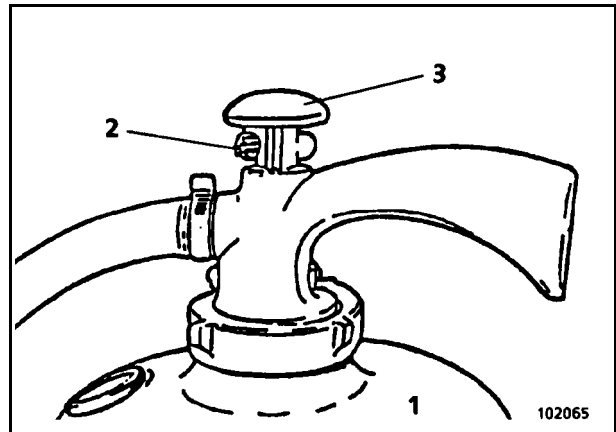

Fig. 2-21:

- Pull out securing pin (2, Fig. 2-21:).
- Strike knob (3) hard, then release again.
- Operate the extinguishing gun.

Inspection

Have the extinguisher inspected at regular intervals by an expert. This is required by local authorities and insurance companies and is in the interest of your own safety.



Have the fire-extinguisher checked at the prescribed intervals by authorized testing agencies

Fig. 2-28:







No.	Element	Function	Symbol
41	Warning lamp CELECT warning (left engine 1)	Lamp is lit up in the event of an Celect fault. The lamp moreover indicates the fault code. Contact Terex Germany after-sales service or engine manufacturer. (see switches 55 and 57)	
42	Warning lamp CELECT warning (left engine 1)	Lamp is lit up in the event of an Celect fault. The lamp moreover indicates the fault code. Shut off the engine Stop working Contact Terex Germany after-sales service or engine manufacturer. (see switches 55 and 57)	
43	Warning lamp CELECT warning (left engine 1)	Lamp is lit up (e.g.): - when the engine oil pressure is too low - when the cooling water temperature is too high Shut off the engine	
44	Warning lamp CELECT warning (right engine 2)	Lamp is lit up in the event of an Celect fault. The lamp moreover indicates the fault code. Contact Terex Germany after-sales service or engine manufacturer. (see switches 65 and 67)	
45	Warning lamp CELECT warning (right engine 2)	Lamp is lit up in the event of an Celect fault. The lamp moreover indicates the fault code. Shut off the engine Stop working Contact Terex Germany after-sales service or engine manufacturer. (see switches 65 and 67)	
46	Warning lamp CELECT warning (right engine 2)	Lamp is lit up (e.g.): - when the engine oil pressure is too low - when the cooling water temperature is too high Shut off the engine	
47	Indicator lamp Boom/stick angle (optional)	Lamp is lit up when the boom/stick angle is in normal working range.	
48	Indicator lamp Boom/stick angle (optional)	Lamp is lit up when the boom/stick angle is in hazard range. (the tracks may be damaged by the working equipment) Increase the angle. The buzzer (34) sounds until the angle has resumed the normal working range.	

Fig. 2-33:









No.	Element	Function	Symbol
91	Switch Emergency Operati- on Boom/Stick	Lowers the boom and stick when actuated in an emergency.	
92	Button Counting dumper	RESET	
93	Switch Stick cylinder switch-off (optional) bypass		
94	Switch Fuel pre-heating (optional)	Switches on the the pre-heating system for the fuel	
95	Switch Lighting	Switches on the lighting for servicing work.	
96	Switch Lighting	Switches the cab lighting on and off.	
97	Switch Windscreen wiper rear window (optio- nal)	Activates permanent wiping	
98	Switch Beacon (optional)	Switches the beacon on and off.	

Fig. 2-38: (optional)

No.	Element	Function	Symbol
165	Warning lamp Slewing motor contaminated 1	Lights up when the slewing motor is contaminated with metal particles.	
166	Warning lamp Slewing motor contaminated 2	Lights up when the slewing motor is contaminated with metal particles.	
167	Warning lamp	free for optional	
168	Warning lamp Hydraulic oil filter contaminated	Lights up when the flow resistance in the filter is too high. Replace filter elements if the warning lamp fails to go out when the oil is at operating temperature.	
169	Warning lamp Min. hydraulic oil level	Lights up when the hydraulic oil level in the hydraulic tank is too low.	
170	Warning lamp Electronic excavator control ON	Lights up when the electronic excavator control is switched on.	
171	Indicator light Hydraulic oil tank	<p>Lights up when one of the shut-off valves of the hydraulic oil tank is closed</p> <p> When the left valve is closed, the LH engine cannot be started.</p> <p>When the right valve is closed, the RH engine cannot be started.</p> <p>When the center valve is closed none of the two engines can be started.</p> <p>When a shutoff valve is closed with the engines running, the respective engine or both engines are stopped.</p>	
172	Thermometer Hydraulic oil	Indicates hydraulic oil temperature in hydraulic tank	
181	Control unit Air conditioner (optional)		
182	Control unit Heating (optional)		

Assemblies resp. reservoirs	Measuring device	Remarks
Cooling system reservoir	Level indicator (4, Fig. 2-53:)	Stop filling when the level indicator indicates maximum filling level. (cf. chapter "Cooling system - Cooling liquid").
Grease container – central lubricating system	BCS display (Fig. 2-54:)	Stop filling when the BCS indicates „grease container is full“. Switch on the display system (optional) with the toggle switch (33, Fig. 2-55:). Stop filling when the grease container is full. The indicator lamp (34) lights up. On completion of filling, switch the display system off again with the toggle switch (33).

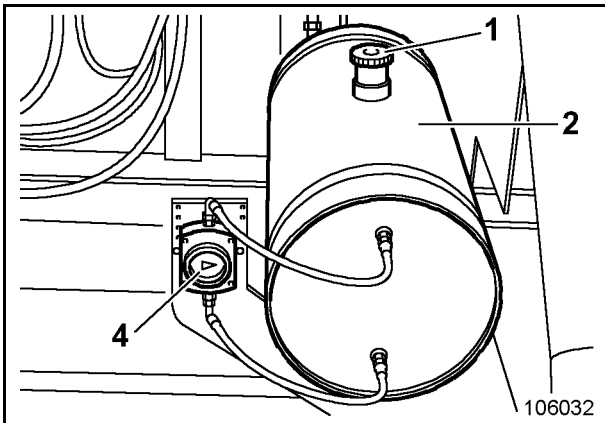

Fig. 2-53:

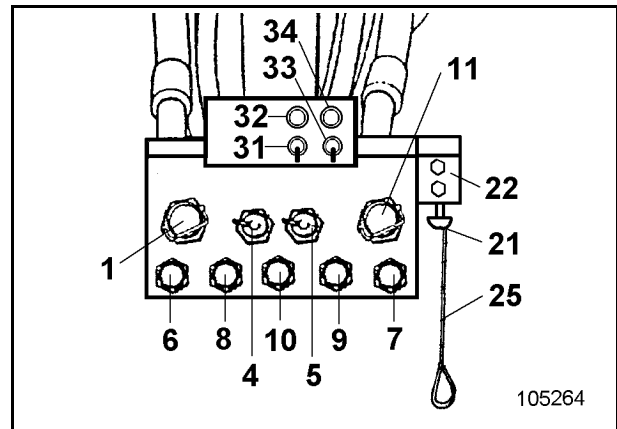

Fig. 2-55:

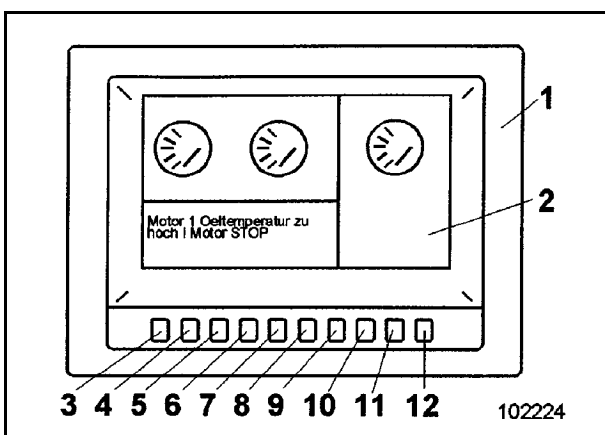

Fig. 2-54:

TRAVELLING

2804916

Superstructure basic position

Travel direction and sense of actuation of pedals (112 and 113, Fig. 2-73:) are identical only when the excavator is in its BASIC POSITION (Fig. 2-72:).

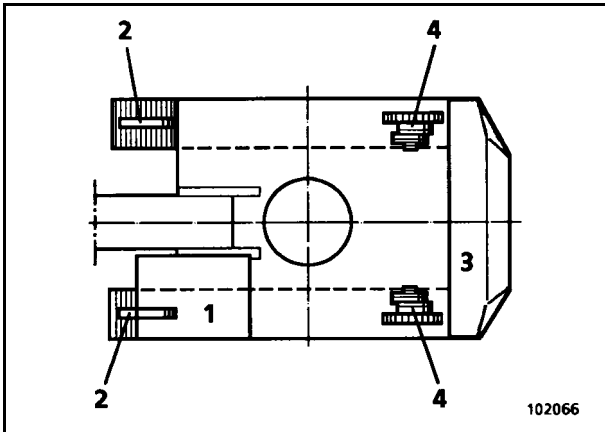

Fig. 2-72:

! If the superstructure is slewed out of its basic position by more than 90° (Fig. 2-74:), the excavator moves in a direction opposite to that expected when pedals (112 and 113, Fig. 2-73:) are depressed.

Travelling forwards/backwards

Travelling forwards:

depress pedals (112 and 113) forwards.

The excavator travels in the direction of the idler (2, Fig. 2-72:).

Travelling backwards:

depress pedals (112 and 113, Fig. 2-73:) backwards.

The excavator travels in the direction of the drive sprocket (4, Fig. 2-72:).

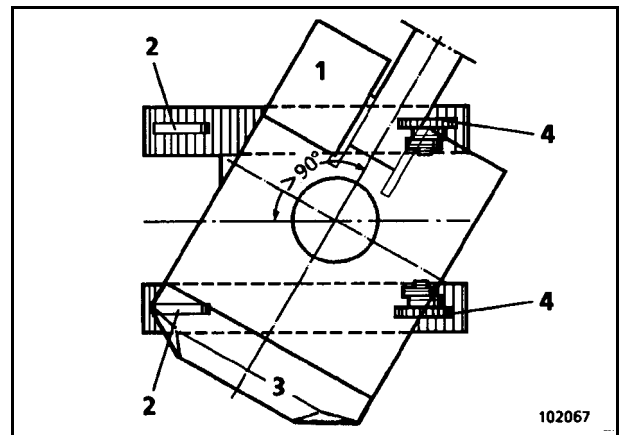

Fig. 2-74:

The pedals return automatically to their "0" positions when released.

Reverse the excavator only over short distances and with the assistance of marshalls because of restricted rear-view conditions.

Do not travel across slopes.

! When travelling uphill or downhill, the travel drive must always be at the rear. Travel only in the basic position of the excavator and only forwards.
Be extremely careful on slippery and greasy ground.

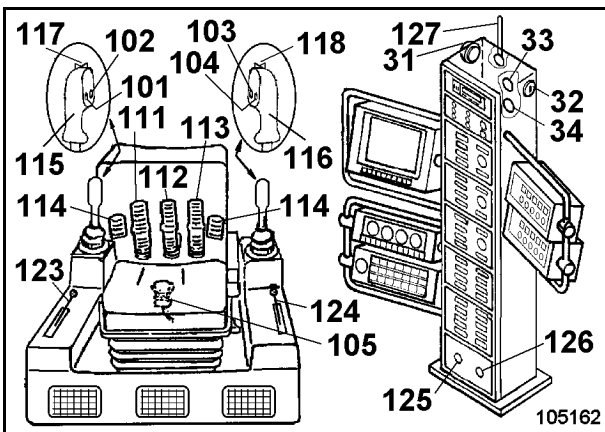

Fig. 2-73:

If the operator is not completely sure of the position of the superstructure with regard to the undercarriage, pedals (112 and 113) should be depressed slightly in order to find out which way the excavator moves before initiating the full travelling movement.

All instructions with regard to travelling speed regulation and travel direction control are applicable only as long as the crawler tracks have sufficient grip and do not slip.

WORKING OPERATION

2804917

Before starting work

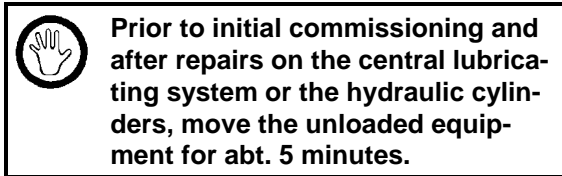

This is required to ensure an adequate supply of grease to the cylinder bearings when the work starts.

Warming up

At low outside temperatures it is necessary to run the hydraulic system up to operating temperature. The temperatures at which warming up is necessary depend on the type of hydraulic oil used; cf. also "Oils for hydraulic systems".

To warm up the system: Run the diesel engines at ca. 2/3 full speed and start to perform no-load working movements for abt. 10 minutes with the excavator.

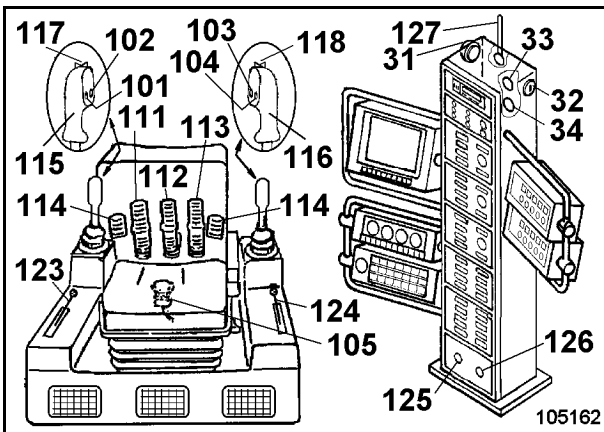

Fig. 2-91:

Switching on the electronic excavator control

The electronic excavator control is switched on and off with switch (105, Fig. 2-91:).

Electronic excavator control activated - operator is sitting on his seat.

Electronic excavator control deactivated - driver's seat is empty.

Slewing and braking the superstructure

The superstructure can only be slewed if the superstructure holding brake is released.

To slew the superstructure to the right: shift control lever (115) to the right.

To slew the superstructure to the left: shift control lever (115) to the left.

After releasing, the control lever returns automatically to position "0".

Braking the superstructure

The superstructure is braked only by setting control lever (115) into the opposite direction (countering).

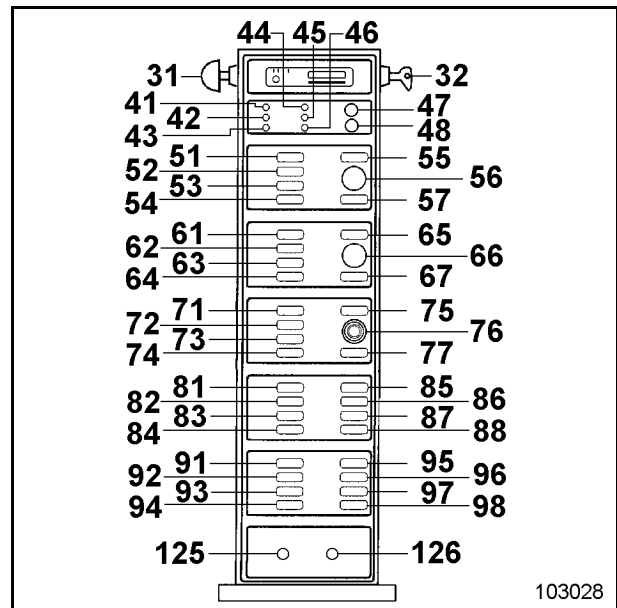

Fig. 2-92:



3 INSPECTION AND SERVICING

2804053

	Operating instructions	Target group
Part 1	INTRODUCTION FUNDAMENTAL SAFETY INSTRUCTIONS	Operating personnel + Inspection and servicing personnel + Repair personnel
Part 2	OPERATION	Operating personnel The operating personnel must have know-how relevant to the operation and the application of this or comparable machines.
Part 3	INSPECTION AND SERVICING	Inspection and servicing personnel The inspection and servicing personnel must have know-how relevant to the inspection and servicing of this or comparable machines.
Part 4	REPAIR WORK	Repair personnel The repair personnel must have know-how and experience relevant to the repair of this or comparable machines.
Part 5	ANNEX	Operating personnel + Inspection and servicing personnel + Repair personnel
Part 6	INDEX	Operating personnel + Inspection and servicing personnel + Repair personnel



INSPECTION AND SERVICING PLANS - INSTRUCTIONS

Intervals

The inspection and Servicing plan lists all jobs which have to be done on the machine at regular intervals.

The individual inspection and Servicing plans are marked with letters providing a link between the operating hours (OH) recorded by the hours-run meter of the machine and the inspection and Servicing plans.

Plan	Do all jobs
V	...once prior to initial commissioning.
N	...after initial commissioning and during the running-in period.
T	...every 10 OH or every working shift ¹⁾
W	...every 60 OH or weekly ²⁾
A	...after every 250 OH.
B	...after every 500 OH.
C	...after every 1000 OH.
D	...after every 5000 OH.
E	...after every 10000 OH.
OH = Bh = Operating hours	

Change of engine oil I

The intervals stated for **changing the engine oil** apply to fuels with a sulphur content of $\leq 0.5\%$ and a permanent ambient temperature down to -10° C.

In case of higher sulphur content and/or a permanent ambient temperature of below -10° C, shorter intervals are required.

If the engine oil change intervals are not reached within **6 months**, the oil must be changed at least **after 6 months**.

Air-intake system

The air filter must be serviced only if the BCS so

indicates. Replace the filter elements after one year at the latest.

Oils / Greases

For the specification of oils and greases to be used refer to the "Lubricants" section.

The numerals mentioned in the "Oil / Grease" column in the inspection and Servicing plans have the following meaning:

I	Oils for combustion engines and compressors
II	Oils for hydraulic systems
III	Oils for gearboxes
V	Greases for bearings and slewing rings

Cleaning jobs

Cleaning jobs, especially on cooling systems, must be done at shorter intervals if the machine is exposed to severe dust build-up.

Components

The maintenance intervals for components, e.g. engine and gearbox, are listed in the following **Terex Germany** maintenance schedules.

It is possible that the manufacturer's documentation for these components states intervals deviating from the above-mentioned intervals.

In such case, only the maintenance intervals specified by Terex Germany shall apply.

² Whichever comes first.

CLICK HERE TO **DOWNLOAD** THE COMPLETE MANUAL

- Thank you very much for reading the preview of the manual.
- You can download the complete manual from: www.heydownloads.com by clicking the link below



- Please note: If there is no response to CLICKING the link, please download this PDF first and then click on it.

CLICK HERE TO **DOWNLOAD** THE COMPLETE MANUAL

OPERATING INSTRUCTIONS RH 120 E

Inspection and servicing



Plan A - after every 250 OH
(at 250, 750, 1250 ... OH)

Plan B - after every 500 OH
(at 500, 1500, 2500 ... OH)

Plan C - after every 1000 OH
(at 1000, 2000, 3000, 4000 ... OH)

Plan D - after every 5000 OH
(at 5000, 15000, 25000 ... OH)

Plan E - after every 10000 OH
(at 10000, 20000, 30000, ... OH)

Page 3 von 8

Location	Servicing work	Menge / No.	Plan A	Plan B	Plan C	Plan D	Plan E
Engine with centrifuge and engine oil reservoir (optional)	Carry out oil analysis	2	●	●	●	●	●
	Change oil	2 ⁷		●	●	●	●
	Clean				●	●	●
	- Bearing				●	●	●
	- Fastening screws				●	●	●
	- Rubber bearing				●	●	●
	Oil filter	Replace	2 x 2	●	●	●	●
	Engine oil reservoir	Change oil	2 ⁷		●	●	●
		Clean				●	●
	V-belt	Check tension		●	●	●	●
		Check condition		●	●	●	●
	Centrifuge	Clean	2 x 1		●	●	●
	- Rotor seal	Replace	2 x 1			●	●
- Casing seal	Check /replace	2 x 1			●	●	
Inspection and servicing	(cf. Operating and maintenance manual for engine)	2	●	●	●	●	

⁷ cf. "Refilling quantities – Oil" table

Lubricating chart – Grease / Backhoe bucket (legend)

No.	Greasing point	Number	Lubricant properties	Grease every operating hours
1	Central lubricating system – grease container	1	V ¹⁸	10
3	Ramp-type ladder (optional)			
	- Deflecting roller	3	V ¹⁸	1000
	- Locking bolt	1	I ¹⁸	1000
4	On-board crane			250
	- Bearing	4	V ¹⁸	250
	- Joint (column / boom)	2		250
	- Cylinder bearing	5		250
	- Slewing ring	1	Graphitspray	250
5	Monitoring, warning and control elements			
	- Joystick	2 x 4 ¹⁹	II ¹⁸	1000
	- Pedal	2 x 2 ¹⁹		1000

All other greasing points are supplied with grease by the central lubricating system.

Filling quantities - Grease

Greasing point	Lubricant properties	Filling quant. in kg
Central lubricating system – grease container	V ¹⁸	500
Internal gearing – Roller-bearing slewing ring		150
Idler (permanent grease filling)	Tribol Terex Germany part no. 2764564	2 x 4.4
Track rollers (permanent grease filling)		14 x 14
Support rollers (permanent grease filling)		4 x 1.3

¹⁸ cf. "LUBRICANTS" section.

¹⁹ apply a thin layer of hydraulic oil

- Draw out dipstick a second time. The oil level should now lie between the marks (arrows, Fig. 3-12:). If the oil level is at the "min" mark or below, top up with engine oil through filler tube (2, Fig. 3-14:).

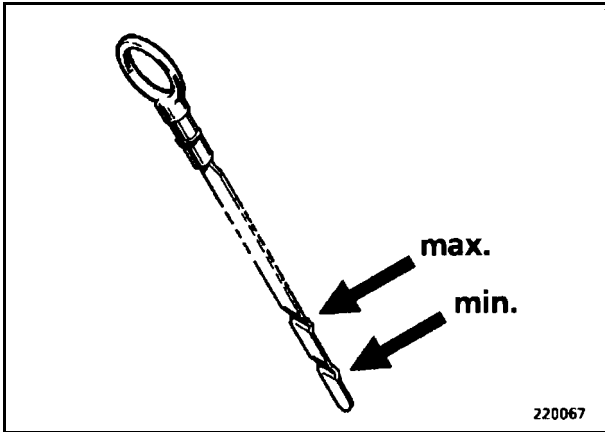

Fig. 3-12:

Engine oil can also be filled in from the service station (Fig. 3-13:) through

- express coupling (8) for the lefthand engine
 - express coupling (9) for the righthand engine
- (see chapter "Changing the engine oil")

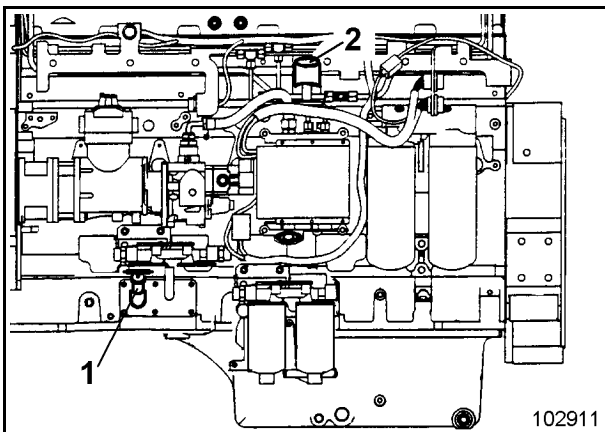

Fig. 3-13:

Checking the oil level in the engine oil reservoir / topping up (optional)

- Park the machine on a horizontal surface and secure against inadvertent movements.
- Shut off engines.

- Unlock the oil dipstick (2, Fig. 3-15:) and withdraw.
- Wipe oil off the dipstick with a clean, lintfree cleaning rag and re-insert.

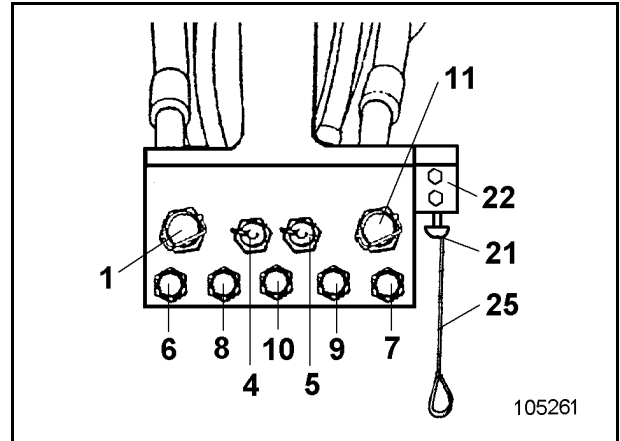

Fig. 3-14:

- Draw out dipstick a second time. The oil level should lie at the mark. If the oil level is below, the engine oil is filled in from the service station (Fig. 3-14:) through
 - express coupling (6) for the lefthand engine oil reservoir
 - express coupling (7) for the righthand engine oil reservoir

(see chapter "Engine oil reservoir - Changing the oil")

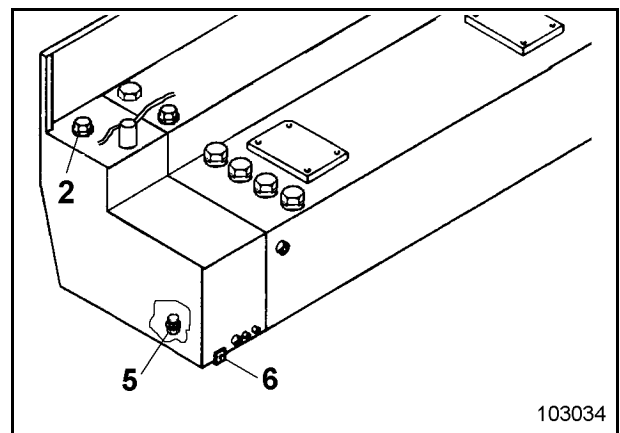

Fig. 3-15:

Water filter



Risk of scalding from hot cooling liquid.

The filter housings may be hot, too.

Wear protective gloves and firm working clothing.
Collect escaping cooling liquid and discard without
polluting the environment.

Replace water filter regularly.

- Close valve (2, Fig. 3-31:).
- Unscrew water filter (3).
- Screw on new water filter until the sealing ring contacts the filter head. Continue to tighten the filter by another $\frac{1}{2}$ to $\frac{3}{4}$ turn.
- Open valve (2).

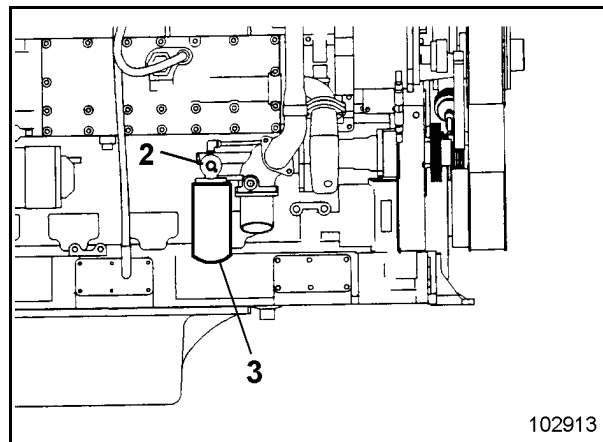
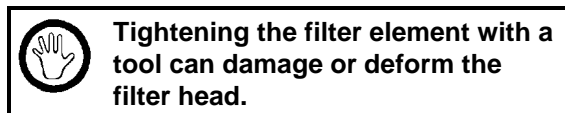

Fig. 3-31:



ELECTRICAL SYSTEM

2804925

Electrical system - Safety instructions

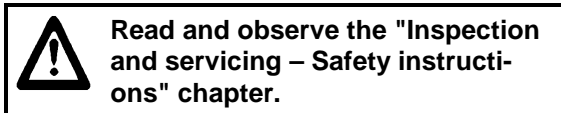

Risk of injury caused by battery acid and gases.

Wear goggles, working gloves and firm working clothing.

Carry out voltage and continuity checks only by means of a test lamp or a measuring instrument. Do not check by "touching ground" with a bare wire. The short-circuit thus produced damages the alternator and the electronic modules of the PMS.

Alternator - Instructions

Never disconnect cables from the alternator, regulator and the battery when the engine is running to avoid damage to the alternator and regulator.

Do not interchange the cables when connecting the battery (observe polarity).

Carry out voltage and continuity checks only by means of a test lamp or a measuring instrument. Do not check by "touching ground" with a bare wire. The short-circuit thus produced damages the alternator and the regulator.

The electrical circuit diagrams are annexed to the spare-parts list. Further information can be found in the Terex - Germany booklet "Working with circuit diagrams".

The electrical system switch-cabinet is located behind the hydraulic reservoir. The cabinet is described in the spare-parts list together with the designation of the electrical components.

Cables and cable lugs must not get in contact with other metal parts. Replace broken or damaged cables and the respective cable lugs.

If a bulb does not work after replacement, the pertaining fuses, connection cables and contacts must be checked.



Changing the hydraulic oil re- turn-flow (hydraulic oil reservoir)

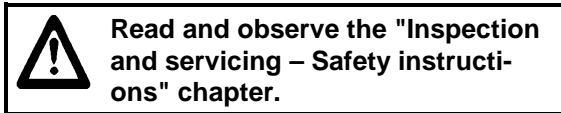

Shut off the engines.

Risk of scalding caused by hot hydraulic oil.

The hydraulic oil reservoir itself may also be hot.

Avoid skin contact.

Skin contact with hydraulic oil may cause skin injury.

Wear protective gloves and firm working clothing.

Collect escaping hydraulic oil and discard without polluting the environment.

The return-flow filters must be replaced:

- when servicing works in accordance with the servicing plan are carried out;
- when the BCS displays a warning on the screen (Fig. 3-73:). In this case, the filter elements (9, Fig. 3-74:) are heavily contaminated;
- after repairs on the hydraulic system;
- in case of damage.

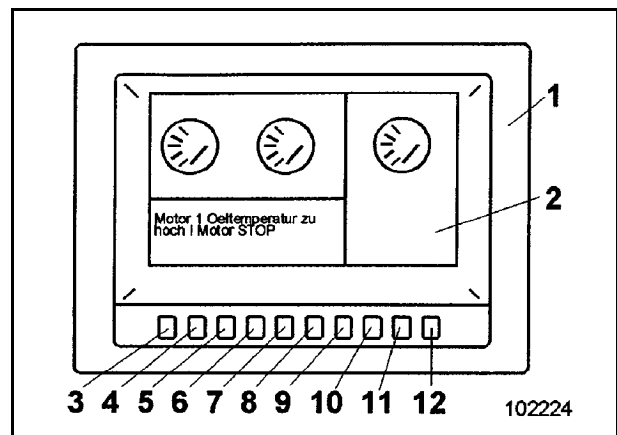

Fig. 3-73:

- ➔ Remove cover (3) together with sealing ring (5) and retaining disk (7).
- ➔ Remove cap (8) and sealing ring (10).
- ➔ Withdraw filter element (9) and sealing ring (11) from basket (12).
- ➔ Insert a new filter element.

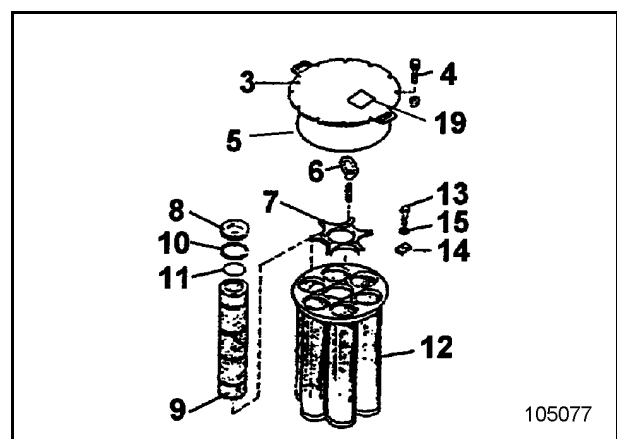

Fig. 3-74:

If a filter element (9) is damaged, remove basket (12) and check/clean.

Drawing off hydraulic oil

The hydraulic oil can also be drawn off through the service station (Fig. 3-88):

- Bring hydraulic oil to operating temperature (ca. 50° C).
- Retract hydraulic cylinders as far as possible and stand working equipment on the ground.
- Shut off the engines.
- Unscrew cap of express coupling (10).
- Connect hose line of the service vehicle.

The hose line and its use are described in the "hose line for oil and cooling liquid change" section.

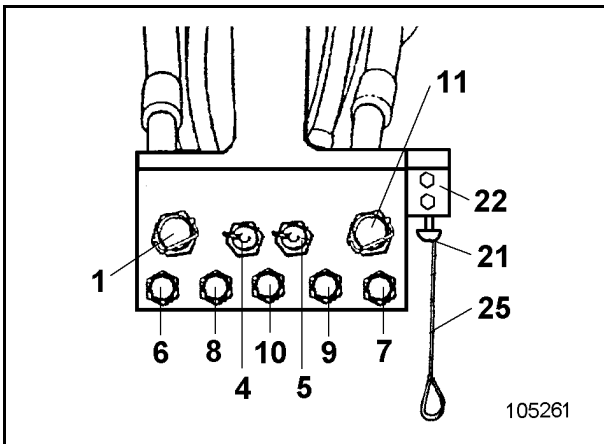



Fig. 3-88:

- Remove hose line. The coupling closes automatically.
- Screw on protective cap.

Cleaning the hydraulic oil reservoir



Explosion hazard.
Read and observe the "Inspection and servicing - Safety instructions" chapter.

Shut off the engines.

Do not use white spirit, paraffin oil or other solvents for cleaning.

Use diesel fuel or a special flushing oil.

Avoid skin contact.

Skin contact with hydraulic oil may cause skin injury.

Wear protective gloves and firm working clothing.

Dispose of contaminated hydraulic oil without polluting the environment and separately from other waste.

- Drain off hydraulic oil as described under "Draining off the hydraulic oil".
- Remove cap (3, Fig. 3-89):..
- Detach the return-flow filter.

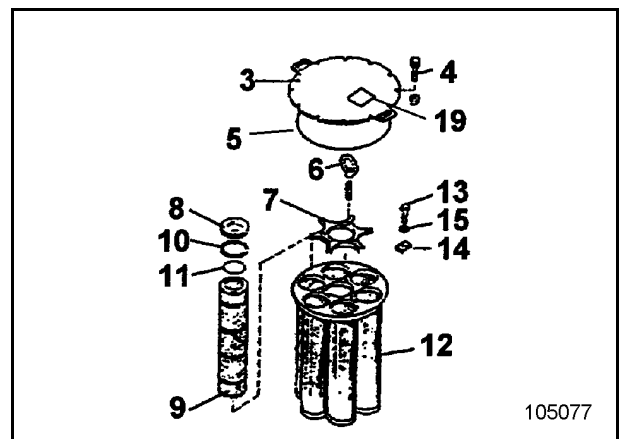

Fig. 3-89:

- Place a collecting recipient for the flushing oil under the hydraulic oil reservoir.
- Clean the inside of the hydraulic oil reservoir with diesel fuel or flushing oil. Remove all sediments and also the residues of the cleaning agent thoroughly
- Refit cap (3).

SLEWING GEARBOX

 **Read and observe: "Inspection and servicing - Safety instructions."**

Shut off the engines

The gearbox housings may be hot, too.

Secure the machine as described in the "Securing the machine" section.

Protect the skin from contact with gearbox oil.

Skin contact with cooling liquid is a potential health hazard.

Wear protective gloves and firm working clothing.

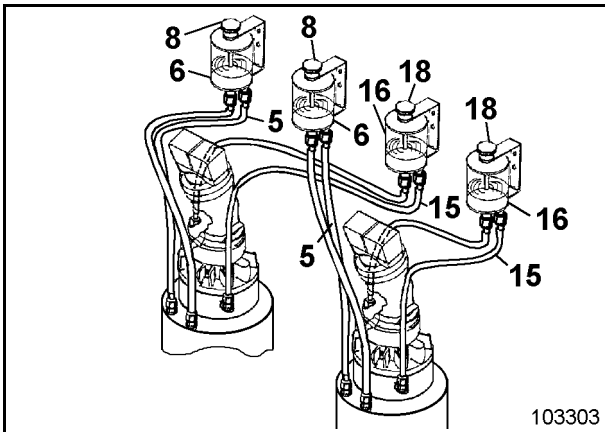

Fig. 3-109:

Gearbox - Checking the oil level / Topping up with oil

- Park the machine as described under "Securing the machine".
- Check the oil level visually at expansion tanks (6, Fig. 3-109:).
The expansion tanks must be filled with gearbox oil up to abt. $\frac{1}{3}$: unscrew cover and top up with gearbox oil if required.

The oil level is visible from outside (light/dark area).

Hose (5, Fig. 3-109:and Fig. 3-111:) connects the gearbox (3, Fig. 3-111:) with the expansion tank (6, Fig. 3-109:).

Brake chamber - Checking the oil level / Topping up with oil

- Check the oil level visually at expansion tanks (16, Fig. 3-109:).
The expansion tanks must be filled with oil up to abt. $\frac{1}{3}$: unscrew cover and top up with oil if required.

The oil level is visible from outside (light/dark area).

Hose (15, Fig. 3-109:and Fig. 3-110:) connects the brake chamber (4, Fig. 3-110:) with the expansion tank (16, Fig. 3-109:).

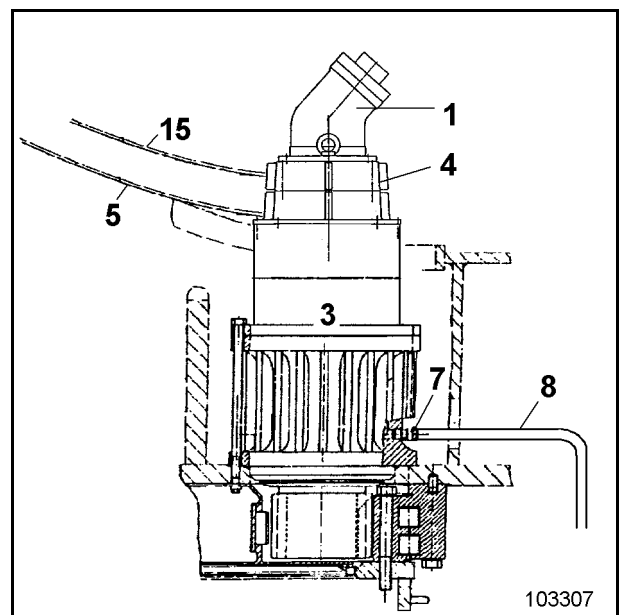

Fig. 3-110:

SLEWING RING

2717762



Shut off the engines.
Wear protective gloves and firm protective clothing.

Slewing ring - Instructions

The grease filling must be replaced:

- when repairs have been carried out on the slewing ring, the slewing ring seals or the slewing ring housing.

Remove old grease completely before filling in new grease.

If greater losses are detected, locate cause immediately to prevent damage to the slewing ring. Greases and greasy cleaning rags must not be allowed to pollute the environment. Discard grease and greasy cleaning rags separately from other waste without polluting the environment.

Bearing races

The **central lubricating system** supplies grease continuously to the two **roller bearing races** and the **internal gearing**.

The grease is pumped to the greasing points of the bearing races by a distributor (Fig. 3-124:).

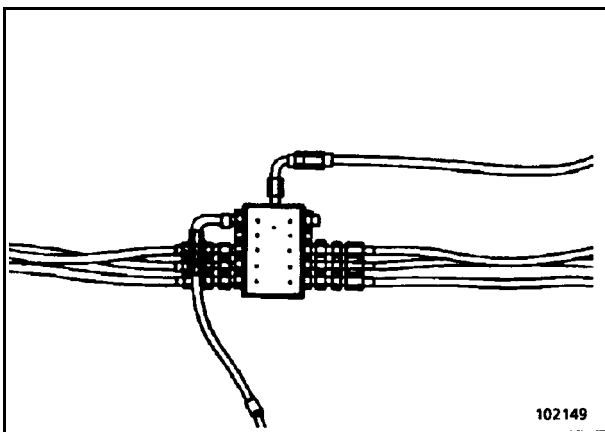

Fig. 3-124:

Internal gearing

The internal gearing (1, Fig. 3-125:) and the pinion (2) are enclosed in a housing (3, Fig. 3-126:). The housing forms a grease-filled trough in which the pinion of the slewing mechanism moves.

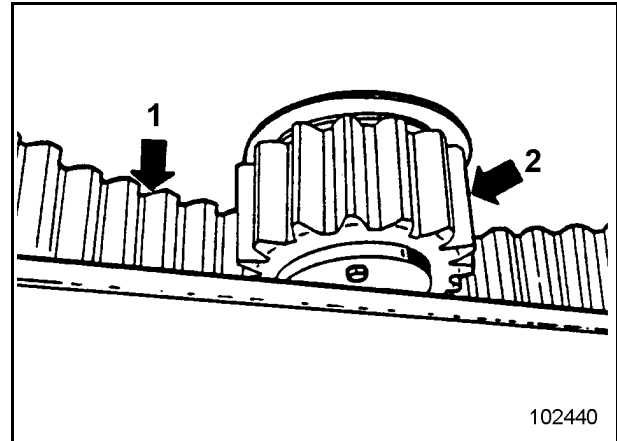

Fig. 3-125:

The grease is pumped to the greasing port of the grease trough by the distributor (Fig. 3-124:). The amount of grease used up during operation is replenished by the central lubricating system.

The housings have a check opening which is closed with a cover (2, Fig. 3-126:). For checking, the cover must be removed.

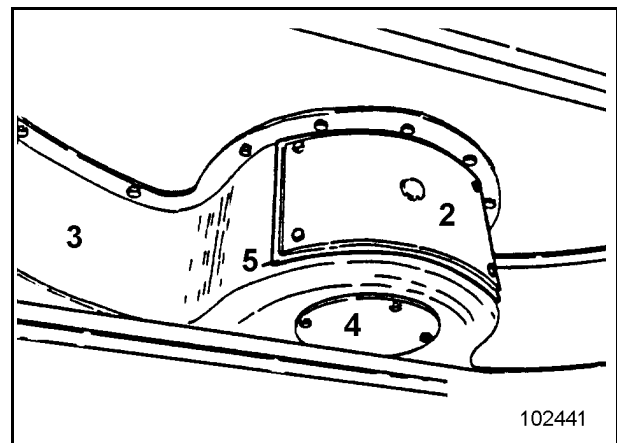

Fig. 3-126:

OTHER MAINTENANCE

2804932

Engine

Information about maintenance can be found in the engine operating instructions.

Further servicing works not described are carried out by the Terex-Germany Service or the engine manufacturer.

Cleaning

Check the engines regularly.

- If the engine is cleaned with a steam-jet cleaner, make sure that the jet is not directed towards electrical components.
- If no steam-jet cleaner is available, the engines must be cleaned with suitable cleaning agents (cold cleaners).

Means of fastening

- ➔ Check fastening screws regularly for tightness.

The seating planes of the screws must be free from paint, dirt and rust.

Cooling system

Check the radiators regularly.

- ➔ Shut off the engines.
- ➔ Remove any accumulated dirt.
- ➔ Clean the fan blades.
- ➔ Clean the radiators with a jet of water or compressed-air from the outside.
- ➔ Dry up coolers.

Do not clean radiators with a wire brush or similar hard objects.

In case of firmly adhering dirt, remove radiator and clean.

Exhaust system

Check the fastening screws regularly for tightness when the exhaust system is cold.

Heating and air conditioning

Change the filter mats in the air suction regularly.

The filter mats are located under the driver's seat.

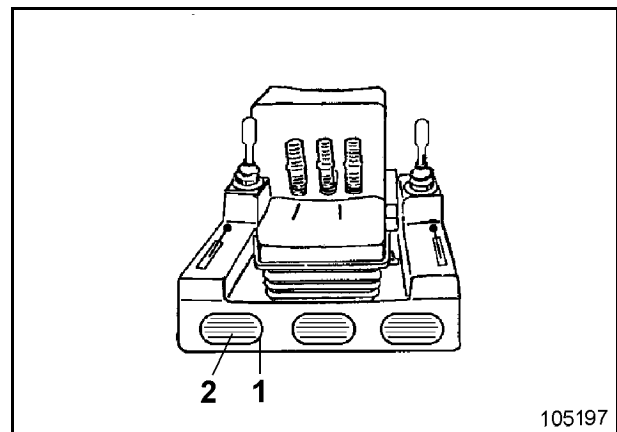

Fig. 3-145:

- ➔ Remove cover (1, Fig. 3-145):-
- ➔ Change filter mats (2)
- ➔ Fasten cover (1) again.

4 REPAIR WORK

28040534

	Operating instructions	Target group
Part 1	INTRODUCTION FUNDAMENTAL SAFETY INSTRUCTIONS	Operating personnel + Inspection and servicing personnel + Repair personnel
Part 2	OPERATION	Operating personnel The operating personnel must have know-how relevant to the operation and the application of this or comparable machines.
Part 3	INSPECTION AND SERVICING	Inspection and servicing personnel The inspection and servicing personnel must have know-how relevant to the inspection and servicing of this or comparable machines.
Part 4	REPAIR WORK	Repair personnel The repair personnel must have know-how and experience relevant to the repair of this or comparable machines.
Part 5	ANNEX	Operating personnel + Inspection and servicing personnel + Repair personnel
Part 6	INDEX	Operating personnel + Inspection and servicing personnel + Repair personnel

WELDING OPERATIONS - SAFETY INSTRUCTIONS

3657352

Never perform welding operations unless you are qualified to do so.

Observe the accident prevention regulations.

Wear protective clothing

- protective suit
- protective gloves
- face protection

Any work on receptacles that contain or have contained substances

- which are combustible or which encourage combustion,
- which are susceptible to explosion,
- or which may develop health-hazardous gases, vapours, mist or dust

during welding operations must be carried out only under expert supervision and only by experienced persons authorized to do such work.

Detailed information on the correct execution of welding operations is given in the technical manual "Welding for maintenance and repair".

Should you have any problems or queries, apply to the Terex Germany after-sales service department.

If parts of the machine have to be dismantled, read and take note of the following sections:

Assembling attachments - safety instructions",

"Inspection and servicing - safety instructions",

"Repair - safety instructions".

Protect the disconnected terminals and plugs from short-circuiting and soiling by covering them with foil or adhesive tape.

Attach the welding-current pincers close to the welding zone (max. 2 - 3 m).

The welding current must not flow via the ball resp. the roller bearing slewing ring, via pin couplings, articulated joints or hydraulic cylinders.

An electric current flowing over an air gap (in an articulated joint, for instance) generates sparks that damage metallic surfaces.

On completion of the welding operation, restore all electrical connections.

Slewing mechanism – Fault table

Fault				Remedial action	
No slewing possible				Check	P
No righthand or lefthand slewing				Adjust	E
Slewing performance insufficient				Replace	W
Uncontrolled slewing movement				Top up	A
				Reduce	S
				Clean	R
				1) Contact the Terex- Germany Service	
Cause				Chapter ref.	
•			Electronic excavator control not activated / defective	Working	P
•			Limiting switch optional, ramp-type ladder not complete retracted	Operation	P
•			Superstructure holding brake applied		P
•	•		Pressure-relief valve adjusted too low level / defective		1)
•			Servo system pump defective		1)
•	•		Malfunction in feed-pressure circuit of slewing pump		1)
	•		Malfunction in high-pressure circuit of slewing system		1)
	•	•	Malfunction of moment-regulating valve		1)
	•	•	Malfunction in slewing pump displacement cylinder		1)
	•		Excessive leakage in slewing motor		1)

CLICK HERE TO **DOWNLOAD** THE COMPLETE MANUAL

- Thank you very much for reading the preview of the manual.
- You can download the complete manual from: www.heydownloads.com by clicking the link below



- Please note: If there is no response to CLICKING the link, please download this PDF first and then click on it.

CLICK HERE TO **DOWNLOAD** THE COMPLETE MANUAL