

# Grove GMK 5200-1

## Operating Instructions

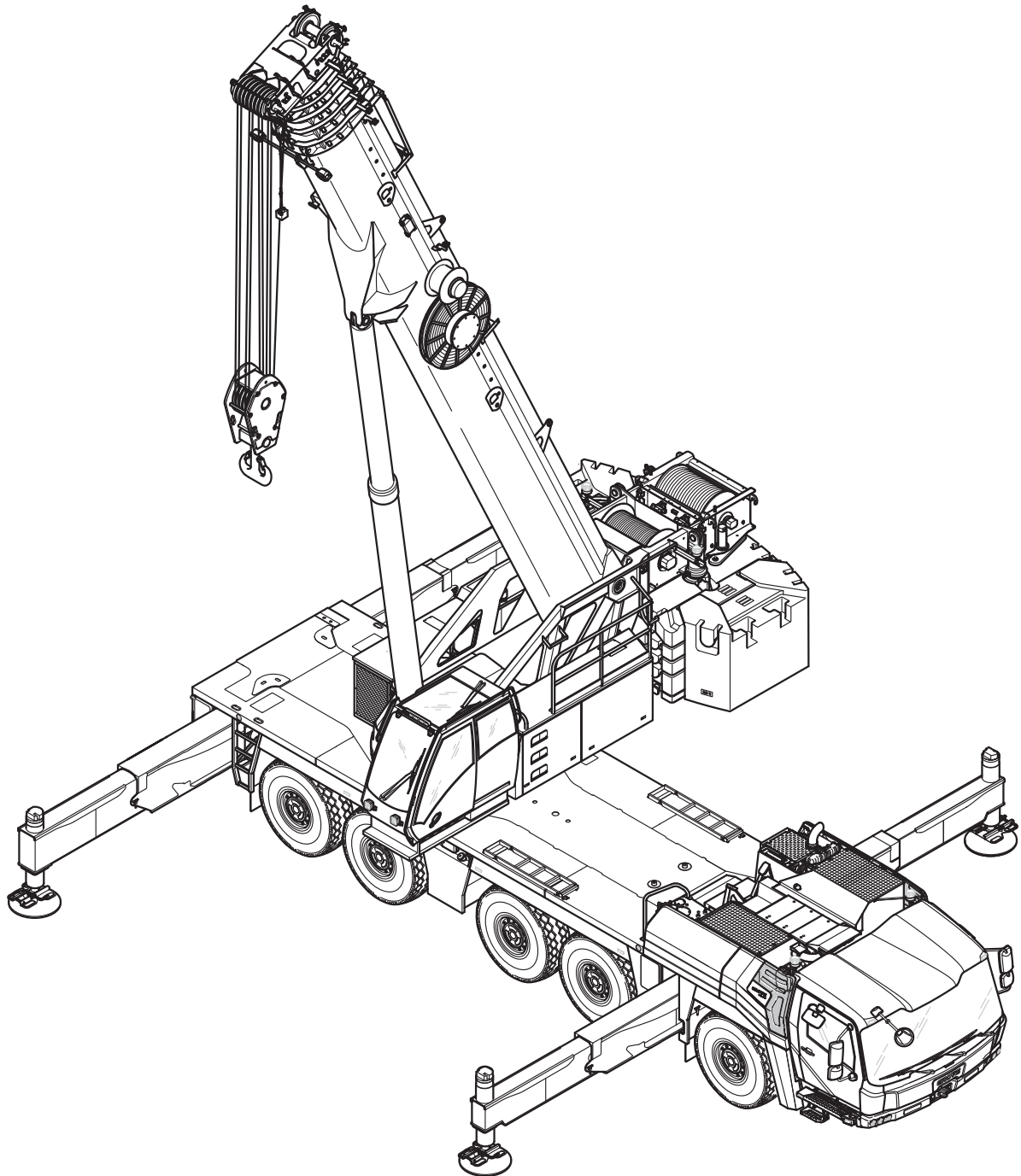

3 302 715 en

08.02.2018

Grove

Manitowoc

National Crane

Potain

**Manitowoc**

CLICK HERE TO **DOWNLOAD** THE COMPLETE MANUAL

- Thank you very much for reading the preview of the manual.
- You can download the complete manual from: [www.heydownloads.com](http://www.heydownloads.com) by clicking the link below



- Please note: If there is no response to CLICKING the link, please download this PDF first and then click on it.

CLICK HERE TO **DOWNLOAD** THE COMPLETE MANUAL

## MAXbase

### Additional outrigger spans

In addition to the information in the supplied *Operating manual* there are lifting capacity tables for further outrigger spans. These additional pages only show the additional outrigger spans.

#### Outrigger span type *Three / One*

Three outrigger beams are extended the same distance and one outrigger beam has a smaller outrigger span.

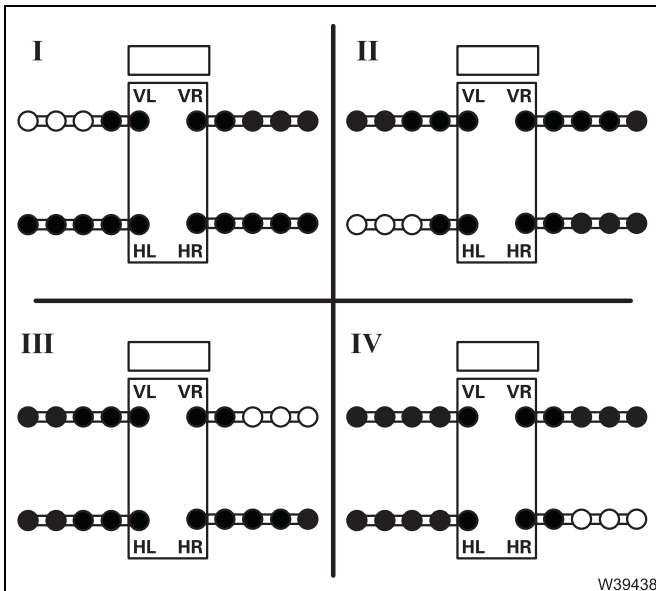

#### GMK5180-1 / GMK5200-1 / GMK5250L

– One outrigger span smaller – Left

	FR	FL	RR	RL
<b>I</b>	3.900 m	2.155 m	3.900 m	3.900 m
<b>II</b>	3.900 m	3.900 m	3.900 m	2.155 m

– One outrigger span smaller – Right

	FR	FL	RR	RL
<b>III</b>	2.155 m	3.900 m	3.900 m	3.900 m
<b>IV</b>	3.900 m	3.900 m	2.155 m	3.900 m

There are no separate lifting capacity tables for this type. The lifting capacities for the type *One outrigger span smaller – left* are enabled in a correspondingly mirrored slewing range; *Supplied operating manual*.

---

## **The operating instructions consist of the following chapters**

- 1 Overview**
- 2 Basic safety instructions**
- 3 Operating elements for driving**
- 4 Starting the engine for driving / switching it off**
- 5 Driving**
- 6 Driving modes and rigging for on-road driving**
- 7 Malfunctions in driving mode**
- 8 Operating elements for crane operation**
- 9 Starting/switching off the engine – for crane operation**
- 10 Crane operation**
- 11 Rigging work**
- 12 Driving with a rigged truck crane**
- 13 Transportation**
- 14 Malfunctions during crane operation**
- 15 Index**

## 5 Driving

<b>5.1</b>	<b>Before driving</b> .....	5 - 1
5.1.1	CHECKLIST: Checks before on-road driving .....	5 - 1
5.1.2	Check the condition of the truck crane .....	5 - 7
5.1.3	Adjusting the seats and steering column .....	5 - 12
5.1.4	Switching the suspension on/off .....	5 - 15
5.1.5	Setting the tachograph .....	5 - 17
5.1.6	Setting the time .....	5 - 22
5.1.7	Displaying and resetting operating hours .....	5 - 23
<b>5.2</b>	<b>Operating the transmission</b> .....	5 - 25
5.2.1	Switching on .....	5 - 25
5.2.2	Switching the transmission to the neutral position .....	5 - 26
5.2.3	Selecting the direction of travel and starting gear .....	5 - 27
5.2.4	Changing the operating mode .....	5 - 29
5.2.5	Starting .....	5 - 30
5.2.6	Driving and changing gears .....	5 - 31
5.2.7	Changing the driving direction .....	5 - 33
5.2.8	Stopping .....	5 - 33
5.2.9	On the roller type dynamometer .....	5 - 34
5.2.10	Preheating transmission .....	5 - 34
<b>5.3</b>	<b>Driving and parking off the truck crane.</b> .....	5 - 35
5.3.1	Checks while driving .....	5 - 35
5.3.2	Cruise control .....	5 - 39
5.3.3	Temposet .....	5 - 40
5.3.4	Driving downhill .....	5 - 41
5.3.5	Driving uphill .....	5 - 44
5.3.6	Override torque reduction .....	5 - 45
5.3.7	Switching the truck crane off .....	5 - 46
5.3.8	Folding berth .....	5 - 48
<b>5.4</b>	<b>Off-road driving</b> .....	5 - 49
5.4.1	Longitudinal and transverse differential locks .....	5 - 50
5.4.2	Operating the level adjustment system .....	5 - 52
5.4.3	Freeing an immobilized truck crane .....	5 - 56
<b>5.5</b>	<b>Separate steering</b> .....	5 - 59
5.5.1	Switching to separate steering .....	5 - 59



## 10 Crane operation

<b>10.1</b>	<b>Before operating the crane</b> . . . . .	10 - 1
10.1.1	CHECKLIST: Checks before operating the crane . . . . .	10 - 1
10.1.2	Check the condition of the truck crane . . . . .	10 - 5
10.1.3	Adjusting the crane cab seat and front control panel . . . . .	10 - 8
10.1.4	Checking the safety equipment . . . . .	10 - 10
10.1.5	Earthing the load. . . . .	10 - 13
10.1.6	Preheating the hydraulic oil . . . . .	10 - 14
10.1.7	Locking/unlocking the superstructure . . . . .	10 - 15
10.1.8	Switching the houselock on/off . . . . .	10 - 17
<b>10.2</b>	<b>Standard slewing range type</b> . . . . .	10 - 21
10.2.1	Permissible slewing ranges and working positions . . . . .	10 - 21
<b>10.3</b>	<b>MAXbase slewing range type</b> . . . . .	10 - 23
10.3.1	Specifications in the lifting capacity tables . . . . .	10 - 24
10.3.2	Enabled slewing ranges . . . . .	10 - 25
10.3.3	Lifting capacities and slewing ranges for outrigger spans without separate lifting capacity tables . . . . .	10 - 28
<b>10.4</b>	<b>Operation of the rated capacity limiter</b> . . . . .	10 - 29
10.4.1	Switch on the RCL . . . . .	10 - 30
10.4.2	Enter rigging mode . . . . .	10 - 32
10.4.3	Pre-selecting telescoping . . . . .	10 - 40
10.4.4	Confirm the rigging mode and lifting capacity table . . . . .	10 - 41
10.4.5	Checks before operating the crane . . . . .	10 - 45
10.4.6	Displays during crane operation . . . . .	10 - 49
10.4.7	RCL early warning . . . . .	10 - 57
10.4.8	RCL shutdown . . . . .	10 - 58
10.4.9	Displaying the lifting capacity tables . . . . .	10 - 59
10.4.10	RCL override – version A . . . . .	10 - 63
10.4.11	RCL override – version B . . . . .	10 - 67
10.4.12	Datalogger . . . . .	10 - 68
<b>10.5</b>	<b>Crane operation with main boom</b> . . . . .	10 - 73
10.5.1	Checks during crane operation . . . . .	10 - 73
10.5.2	Main hoist . . . . .	10 - 75
10.5.3	Auxiliary hoist . . . . .	10 - 79
10.5.4	Lifting limit switch and lowering limit switch . . . . .	10 - 82
10.5.5	Derricking gear . . . . .	10 - 85
10.5.6	Telescoping mechanism . . . . .	10 - 89



---

**15     Index**

## Dimensions

All dimensions relate to on-road mode;  *Driving modes*, p. 6 - 1.

Length without auxiliary hoist:	15.68 m
<b>A</b> Height:	At on-road level:
– 385/95 R25	3.94 m
– 445/95 R25	3.99 m
– 525/80 R25	3.99 m
Max. level change	-130/+170 mm
<b>B</b> Width:	
– 385/95 R25	2.97 m
– 445/95 R25	2.97 m 3.07 m
– 525/80 R25	
Angle of negotiable banks:	At on-road level (385/95 R25)
front:	approx. 16°
rear:	approx. 8°

## Weight and axle loads

For equipment with the specified axle loads in on-road mode;  *Driving modes*, p. 6 - 1.

Dimensions and weights of the parts which have to be transported on separate vehicles when driving on the road;  p. 1 - 10.

Total weight:	depending on driving mode 60 t
Axle loads:	depending on driving mode 12 t

## 1.5.5

### Superstructure

#### Main hoist

Drum diameter:	458 mm (rope centre to rope centre)
Rope diameter:	22 mm
Rope length:	300 m
Rope pull:	104 kN/line
Power unit group:	M 3 (to ISO 4301 - 2)
Load spectrum:	L 1
Factor of the load spectrum	$K_m = 0.125$
Theoretical service life:	$D = 3,200$ h

#### Auxiliary hoist

Drum diameter:	458 mm (rope centre to rope centre)
Rope diameter:	22 mm
Rope length:	300 m
Rope pull:	104 kN/line
Power unit group:	M 3 (to ISO 4301 - 2)
Load spectrum:	L 1
Factor of the load spectrum	$K_m = 0.125$
Theoretical service life:	$D = 3,200$ h

#### Slewing gear

Make:	Siebenhaar
Type:	01 DD
Power unit group	M2 (to ISO 4301 - 2)



### 1.7.3

## How do I find the information I need?

The operating manual contains the following guides for orientation.

- The **Contents** lists all chapters in the operating instructions.
- The **Table of contents** provides an overview of the topics.
- The **Index** in chapter **15** gives an alphabetic list of keywords and search terms with a reference to the relevant page in the operating manual.
- Cross-references are labelled with an arrow (▮▮▮▮▶) and refer to other pages in the operating instructions. These pages contain more detailed information, or information that relates to the topic in question. Furthermore, you can use the cross-references to systematically familiarize yourself with general to specific information on the truck crane or look up the functioning of individual elements.

The following pages give an example of how to use the cross-references.



# 2

## Basic safety instructions



Notes on the warnings used;  *What do the symbols used mean?*, p. 1 - 25.

### 2.1

#### Intended use

The GMK5200-1 truck crane is constructed in accordance with the latest technology and the recognised safety regulations. Nevertheless, the operator or third parties can still be endangered and the crane or other property put at risk while using it.

The truck crane may only be modified with the consent of **Manitowoc Crane Group Germany GmbH**.

The GMK5200-1 truck crane may be used only when it is in perfect technical condition and for its intended purpose and with due attention paid to safe operation and possible hazards.

Any malfunctions that could impair safety must be eliminated immediately.

The GMK5200-1 truck crane may only be operated without the corresponding special equipment within the permitted temperaturerange;  *Technical data*, p. 1 - 7.

The GMK5200-1 truck crane is designed solely for lifting loads which are within the permitted GMK5200-1 lifting capacities. The load must be slung as prescribed to a hook block which is positioned vertically over the load prior to lifting.

**Intended use** also includes

- observing the entire crane documentation, consisting of the operating manual(s), the lifting capacity table, the outrigger pressure table and the safety manual
- adhering to the inspection and maintenance requirements specified in the maintenance manual.

The GMK5200-1 may only be operated with parts of equipment which have been approved by **Manitowoc Crane Group Germany GmbH** and which are labelled with the serial number of the GMK5200-1.

The manufacturer is not liable for any damage caused by improper or unauthorized use of the GMK5200-1 truck crane. The user shall take on full responsibility for any such use.

The crane operator must have knowledge of and meet the requirements of the relevant legal regulations and standards (e.g. the BGR 159 in Germany or the ASME B30 in the USA).

The crane operator must have the necessary knowledge for operating the truck crane and the equipment used for lifting persons.

The crane operator and the persons to be transported must be made aware of all the known dangers involved when transporting persons.

## Operation

Operations planning for transporting persons must be carried out with special care. If official registration is required in the country in which you are working, this must be done with the relevant authorities in good time.

The truck crane must be rigged as prescribed and be level.

Before transporting persons, the crane operator must make sure that the safety devices and emergency operation functions are in perfect working order.

Before transporting persons, the crane operator must make sure that the lifting limit switch is **not** overridden.

The *operating manual* and the *lifting capacity table* must be stored in the crane cab and within easy reach of the crane operator.

All crane movements must be performed slowly and with extreme care.

The crane operator is not allowed to leave the crane cab until the equipment for lifting persons has been set down and the person transported has left it.

The crane operator must take care that the degree of utilisation does not exceed 50% during operation.

The number of reeved rope lines must be selected such that the load on the hoist rope does not exceed 50% of the rope pull. At the same time, the total weight of the lifted load must be considered, consisting of the weights of the hook block, the lifting gear and the equipment for lifting persons including the maximum payload.

When transporting persons, the crane operator must maintain the safe distances from overhead power lines applicable in the country in which he is working. The distances are normally greater than the distances for lifting loads specified in the section *Safe distance from overhead power lines*.



<b>20</b>	Radio <sup>1), 2)</sup>	
<b>21</b>	BirdView-System 270°- monitor <sup>1)</sup>	▣▣▣▣▶ p. 3 - 57
<b>22</b>	Heating/Air-conditioning system <sup>1)</sup>	▣▣▣▣▶ p. 3 - 20
<b>23</b>	CCS control unit	▣▣▣▣▶ p. 3 - 24
	Reverse camera monitor	▣▣▣▣▶ p. 3 - 56
<b>24</b>	Loudspeakers	
<b>25</b>	Sockets 12 V/24 V	▣▣▣▣▶ p. 3 - 50
	Cigarette lighter	
	Ashtray	
<b>26</b>	Behind the cover	▣▣▣▣▶ p. 3 - 10
<b>27</b>	Fastening for the folding berth <sup>1)</sup>	▣▣▣▣▶ p. 5 - 48
<b>28</b>	Cab lighting	▣▣▣▣▶ p. 3 - 71
<b>29</b>	Battery heater <sup>2)</sup>	
<b>30</b>	Auxiliary air heater <sup>1)</sup>	▣▣▣▣▶ p. 3 - 23

<sup>1)</sup> Additional equipment

<sup>2)</sup> ▣▣▣▣▶ *Separate operating instructions*



### 3.1.7

## Tachograph

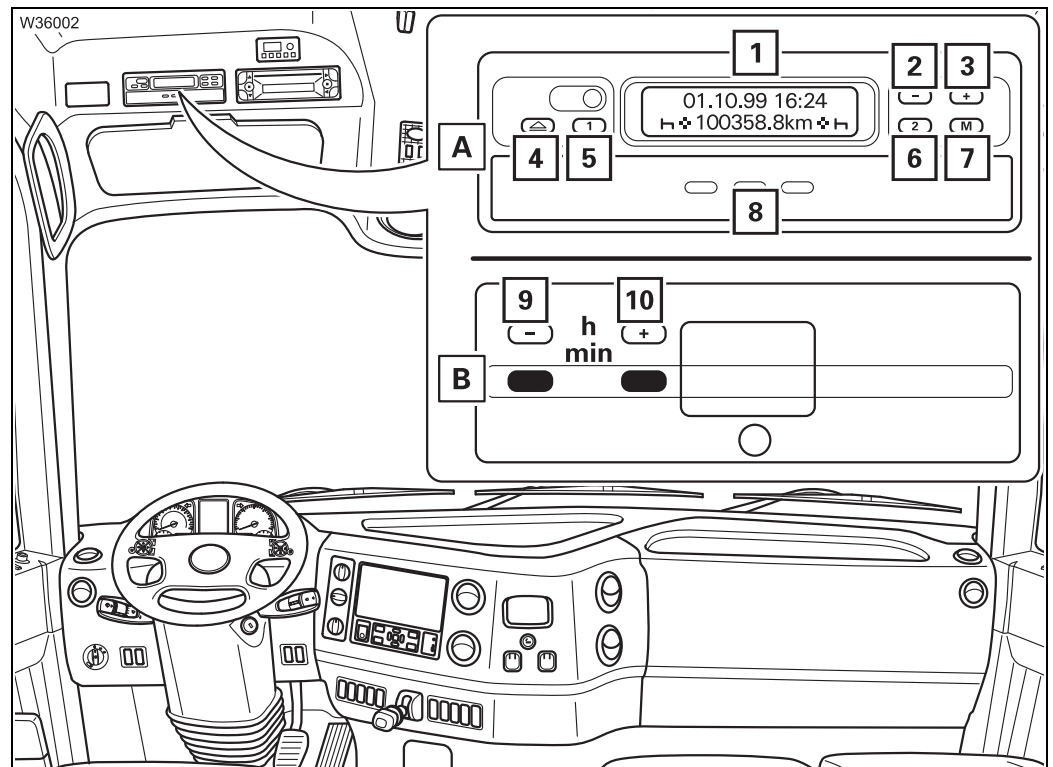

#### (A) – Tachograph<sup>1)</sup>

- |                                     |             |
|-------------------------------------|-------------|
| 1 Display                           | ➡ p. 5 - 20 |
| 2 Time correction –:                | ➡ p. 3 - 74 |
| 3 Time correction +:                | ➡ p. 3 - 74 |
| 4 Opening the drawer                | ➡ p. 5 - 18 |
| 5 Setting the time group – driver 1 | ➡ p. 5 - 19 |
| 6 Setting the time group – driver 2 | ➡ p. 5 - 19 |
| 7 Tachograph                        | ➡ p. 3 - 74 |
| 8 Drawer                            | ➡ p. 5 - 18 |

#### (B) – Cover<sup>1)</sup>

- |                       |             |
|-----------------------|-------------|
| 9 Time correction –:  | ➡ p. 3 - 74 |
| 10 Time correction +: | ➡ p. 3 - 74 |

<sup>1)</sup> (A) or (B) present, depending on the version

- 1 Carrier menu group** ▣▶ p. 3 - 30
  - Suspension/ level adjustment menu
  - Driving menu
- 2 Settings menu group** ▣▶ p. 3 - 33
  - Set display brightness and date/time menu
- 3 Information menu group** ▣▶ p. 3 - 35
  - Operating hours menu
  - Engine/transmission error menu
  - Crane operation error menu
- 4 Various controls menu group** ▣▶ p. 3 - 39
  - Spotlights on rear of carrier on/off
  - Reverse camera on/off<sup>1)</sup>
- 5 Emergency operations menu group** ▣▶ p. 3 - 39
  - Hydraulic emergency operation on/off
  - Towing mode on/off

<sup>1)</sup> Additional equipment

### 3.1.16

### Various controls menu group

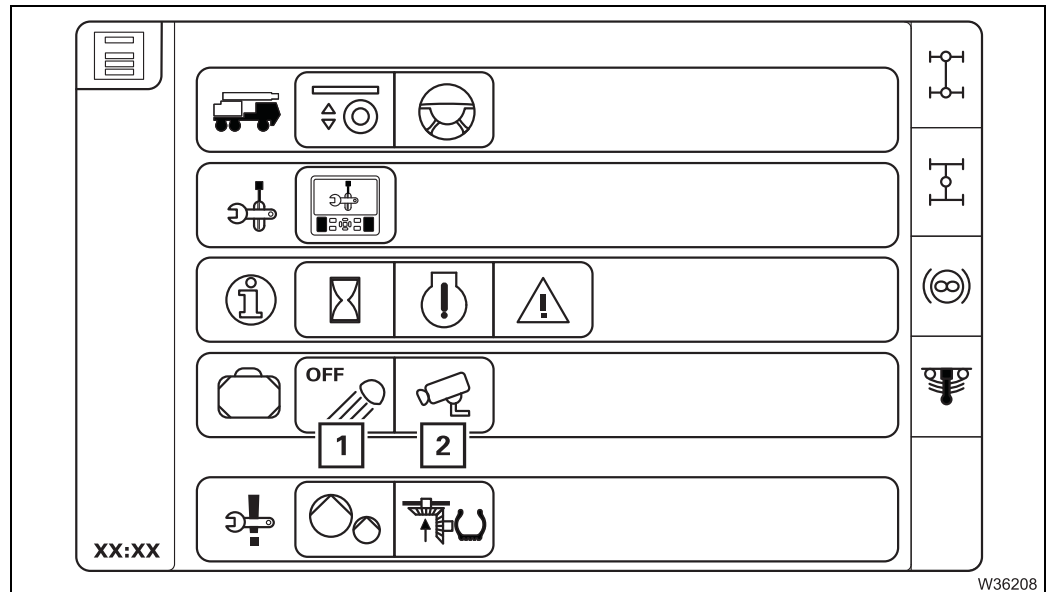

1 Spotlights on rear of carrier on/off

▣▣▣▣ p. 3 - 70

2 Reverse camera on/off

▣▣▣▣ p. 3 - 56

### 3.1.17

### Emergency operations menu group

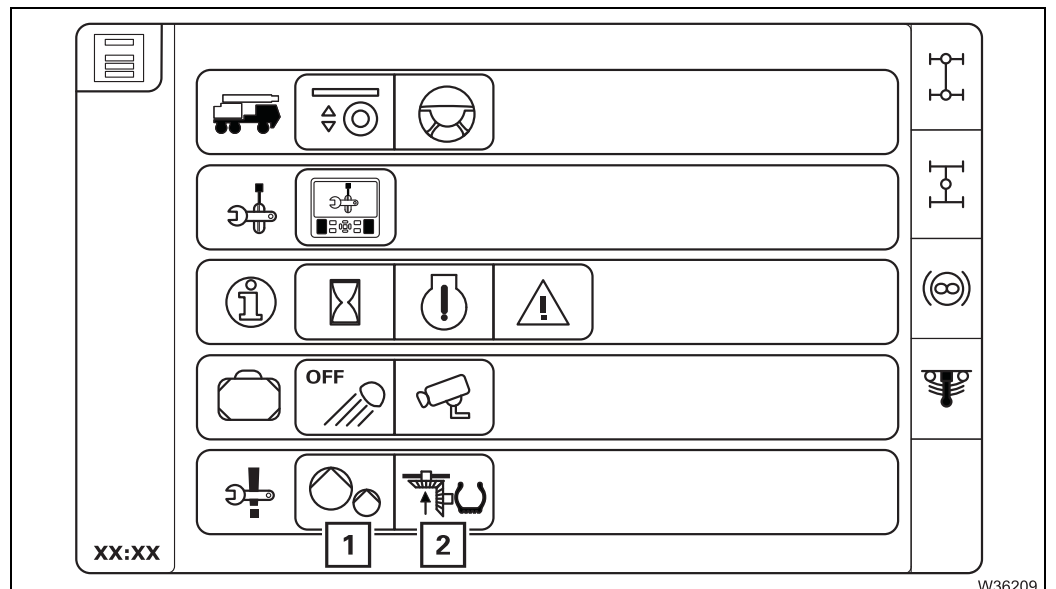

1 Hydraulic emergency operation on/off

▣▣▣▣ p. 14 - 54

2 Towing mode on/off

▣▣▣▣ p. 7 - 27

## CCS display

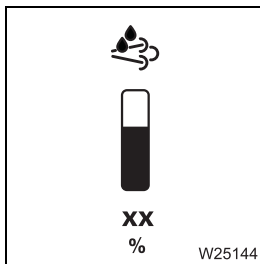

### Adblue filling level monitoring submenu

- **Display**      **Green:** Over 10% – over 4 l
- Yellow:** 5 to 10% – 2 to 4 l
- Red:** Below 5% – less than 2 l

## 3.2.5

### Battery master switch

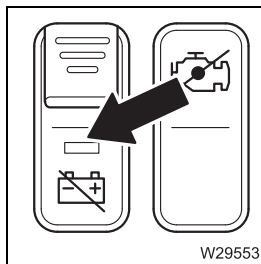

- **Switch on:** Push up
  - **To switch off:** unlock and then press in downwards
- ➡ p. 4 - 11

### 3.2.11

## Final drive

▮▮▮▮▮ *Longitudinal and transverse differential locks, p. 5 - 50*

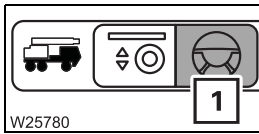

### Driving menu

**To open:** Select symbol (1) and confirm – menu is opened

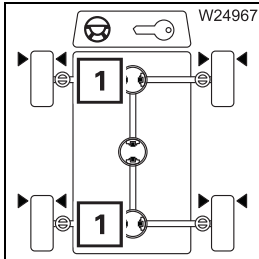

### Transverse differential locks on/off

- **To switch on:** Select symbol (1) and confirm – symbol is **red**
- **To switch off:** Select symbol (1) and confirm – symbol is **green**

When a symbol (1) is selected **both** transverse differential locks are switched on or off.

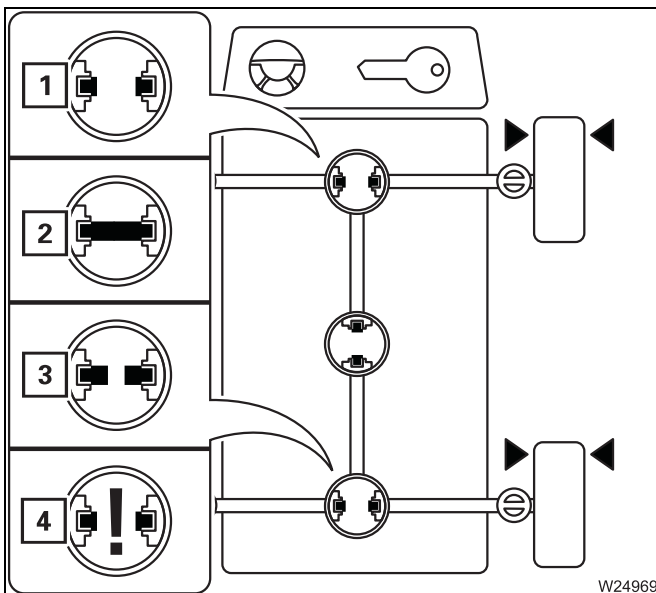

### Transverse differential locks display

The current status is shown using different symbols:

- 1 green** – locks off
- 2 red** – locks on
- 3 yellow** – intermediate position
- 4 violet** – error

▮▮▮▮▮ p. 5 - 50



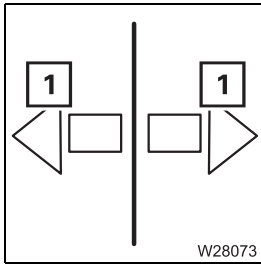

### Indicator lamp for turn signal indicator

- 1 - Flashing:** Turn signal indicator on
- Off:** Turn signal indicator off, or turn signal indicator on and filament lamp faulty

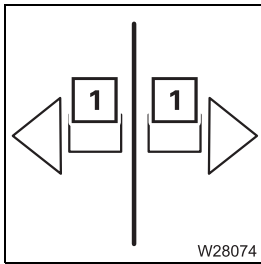

### Indicator lamp for trailer turn signal indicator

- 1 - Flashing:** Turn signal indicator on and trailer electrically connected
- Flashes once:** Turn signal indicator on and trailer not electrically connected
- Off:** Turn signal indicator off

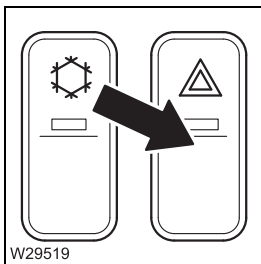

### Hazard warning system on/off

- To switch on:** Press downwards – light in the switch flashes
- To switch off:** Press in above – gone out

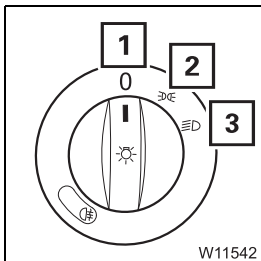

### Lighting on/off

- 1 Light off**
- 2 Parking light on** Instrument lighting on
- 3 Headlight on** Full beam can be switched on using the multipurpose switch, daytime driving light off



## Doors

The same key is used for the driver's and passenger door.



Always take the ignition key with you before closing the door from outside with the handle pressed in (2). Once closed in this manner, the door can only be opened again using the ignition key.

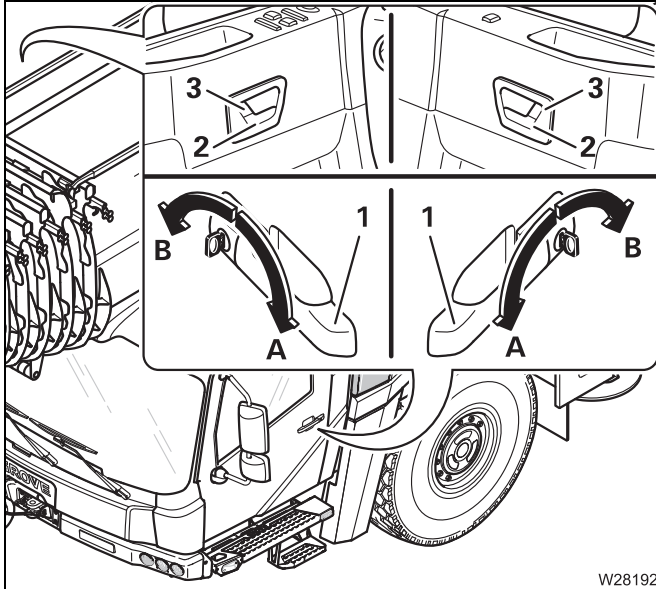

### Locking

- Turn the key towards **B**, or
- Press in the handle (**3**)

### Unlocking

- Turn the key towards **A**, or
- Pull the handle (**3**)

### Opening

- Pull the handle (**1**) or
- Pull the handle (**2**)

## Keys

Different keys are supplied.

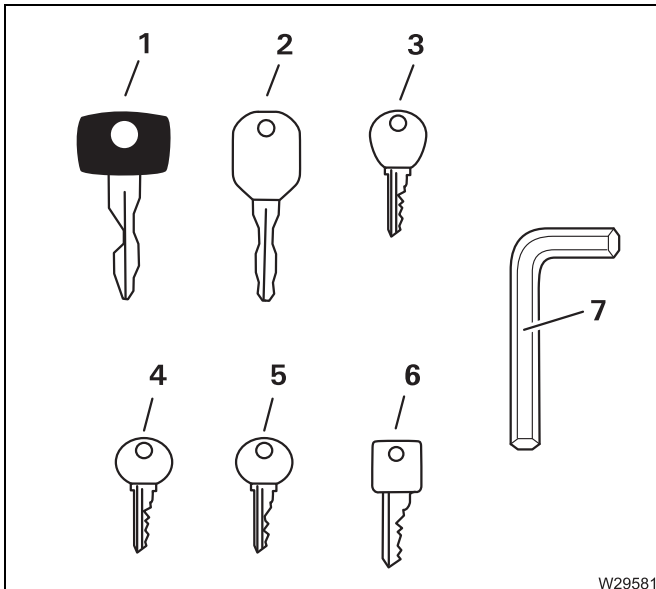

- 1 Door locks/ignition lock of driver's cab
- 2 Fuel tank<sup>1) 2)</sup>
- 3 Control units for outriggers<sup>1)</sup>
- 4 Windscreen washing system reservoir
- 5 Boom floating position lock<sup>1)</sup>
- 6 Slewing gear freewheel lock
- 7 Covers

<sup>1)</sup> Additional equipment

<sup>2)</sup> Depending on equipment, key (1) or (3)

## AdBlue

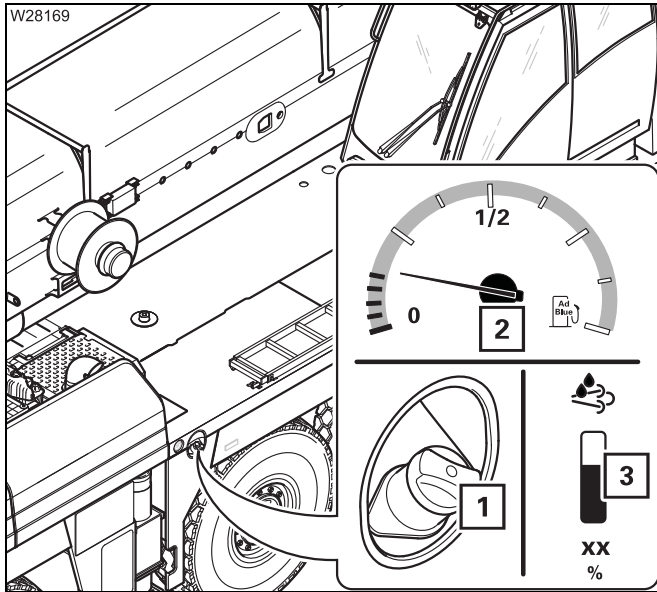

The displays (2) and (3) indicate the current filling level.

The level indicator (3) changes colour depending on the fill level:

**Green:** Over 10% – over 4 l

**Yellow:** 5 to 10% – 2 to 4 l

**Red:** Below 5% – less than 2 l

- Refill the *AdBlue* tank (1) in good time and close it using the cap.

When the *AdBlue* tank is used up, the engine control system will reduce the motor torque. You can override this torque reduction;  *Override torque reduction*, p. 5 - 45.



### **Risk of injury from ammonia vapours!**

Ammonia vapours can escape if the *AdBlue* tank is opened at high outside temperatures. Ammonia vapours can irritate mucous membranes, skin and eyes.

Ensure that there is adequate fresh air supply and do not breathe in the escaping ammonia vapours.



### **Risk of damage to painted or aluminium surfaces!**

*AdBlue* can cause corrosion of these surfaces. Clean up spilled *AdBlue* with water immediately.



In order to comply with exhaust emission regulations, the truck crane may only be driven with *AdBlue*. Driving without *AdBlue* will invalidate the truck crane's licence for use on public roads and you are no longer permitted to drive on public roads.

## 4.1.11

### Monitoring elements

#### Instrument panel

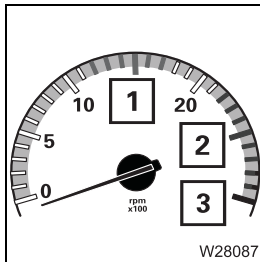

#### Tachometer

- 1 Green:** Economic consumption
- 2 Yellow:** Engine brake active
- 3 Red:** Engine speed too high – danger;  
▮▮▮▮▮ Checks when driving downhill, p. 5 - 42

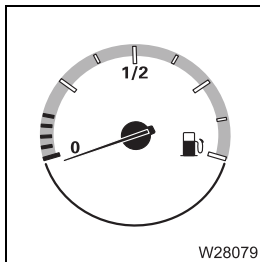

#### Fuel level display

Never run the fuel tank completely dry; always refuel in time; ▮▮▮▮▮ p. 4 - 7.  
If the fuel tank is almost empty, air can be sucked in and the fuel system must then be bled; ▮▮▮▮▮ *Maintenance Manual*.

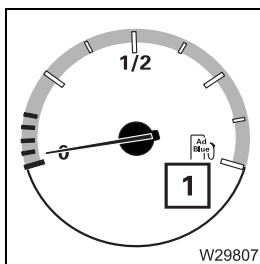

#### Adblue filling level indicator

- 1 Lights up:** Adblue tank empty  
▮▮▮▮▮ p. 4 - 9

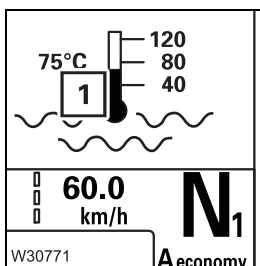

#### Coolant temperature display – in the on-board computer display

- 1 Coolant temperature display in degrees Celsius**  
In the event of malfunctions; ▮▮▮▮▮ p. 7 - 17

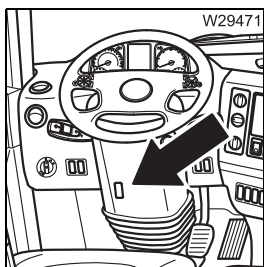

21. Adjust the steering column; p. 5 - 14.

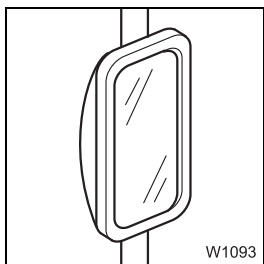

22. Adjust the mirrors; p. 5 - 7.

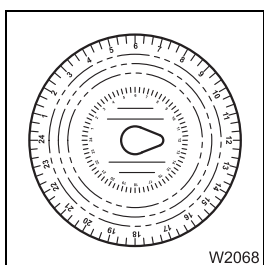

23. Set the tachograph, insert the diagram sheet; p. 5 - 17.

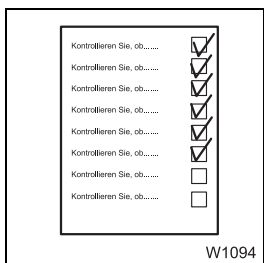

24. Start the engine and carry out all checks; *Inspections after starting the engine*, p. 4 - 16.

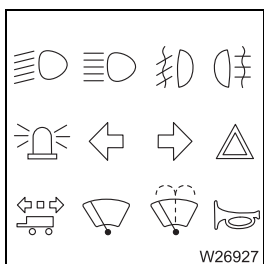

25. Check the electrical system; p. 5 - 7.



## 5.1.4 Switching the suspension on/off

The suspension is switched off whenever the ignition is switched off.  
The suspension must be switched on for on-road driving.

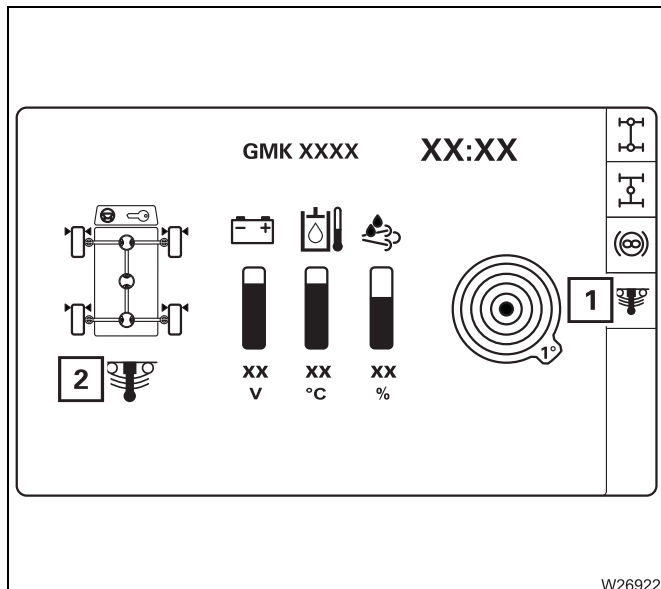

The current switching state of the suspension is shown on the display (1) in all menus and also in the main menu (2).

Symbol (1) or (2)

- Green:** Suspension is switched on
- Red:** Suspension is switched off
- Violet:** Error

To switch the suspension on and off, you must open the *Suspension/level adjustment* menu.

### Open menu

You can open the menu only when the truck crane is stationary, or when the current speed is below approx. 5 km/h .

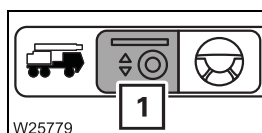

- Open the *Suspension/level adjustment* menu (1).



## 5.2

## Operating the transmission

The transmission automatically controls all gear changes. Despite this, gears can be changed manually at any time.

### 5.2.1

### Switching on

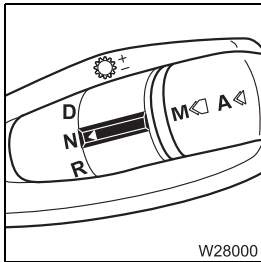

When the ignition is switched off, the transmission must always be in the neutral position.

- Shift to position **N**.

If you switch on the ignition in positions **D** or **R**, malfunctions may occur.

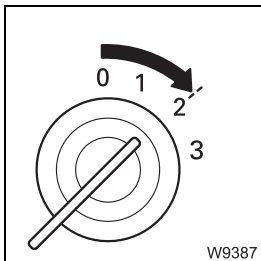

- Switch on the ignition.

The electronic gear system is switched on, and a warning buzzer sounds for several seconds.

## 5.3

## Driving and parking off the truck crane



### Risk of accidents because the truck crane cannot be steered!

Never switch off the ignition or remove the ignition key while the truck crane is moving!

This precaution prevents the steering from locking and consequent loss of control of the moving truck crane.



### Risk of accident when the ignition is switched off!

Never switch off the ignition while driving.

After switching off the ignition the 4th and 5th axle lines are brought into forward alignment and can no longer be moved.

This changes the turning radius of the truck crane.

### 5.3.1

### Checks while driving

#### Immediately after you start to move

- Check the service and parking brakes for correct functioning immediately after starting out.
- Check the lamps (1).

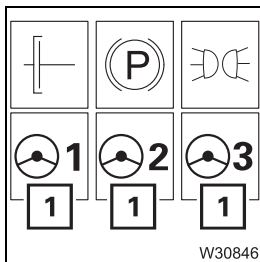

At speeds above 10 km/h **all** the lamps must go out. If a lamp does not go out, this indicates a malfunction in the steering.

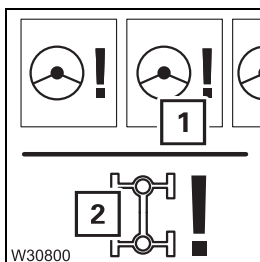

- The lamp (1) lights up when an error is detected in the steering system – the symbol (2) is shown. The 4th and 5th axles are brought into the straight running position and can no longer be steered. It is possible to continue driving. Steering is now only possible with the 1st and 2nd axle lines – the turning radius increases accordingly.

- Have the error rectified as soon as possible.

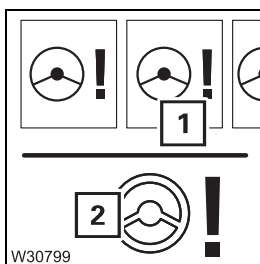

- The lamp (1) lights up when a serious fault is detected in the steering system – the symbol (2) is shown. The 4th and 5th axle lines can no longer be steered in a controlled manner.

- Stop the vehicle as soon as possible. Briefly switch the ignition off then on again. If the lamp is still lit, contact **Manitowoc Crane Care**.



### 5.3.6 Override torque reduction

When the Adblue (DEF) supply is empty, the torque reduction is activated via the engine control system.

You can override torque reduction up to 3 times.

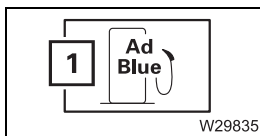

– If the level in the *AdBlue* tank falls to the reserve level, then the symbol (1) is displayed.

- Immediately fill up with *AdBlue*;  *AdBlue*, p. 4 - 9.

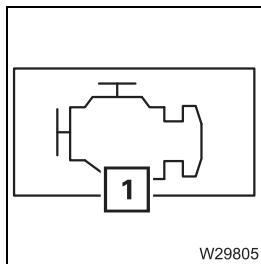

– If the *AdBlue* tank is empty, the lamp (1) will flash.

The engine torque is reduced the next time the engine is started.

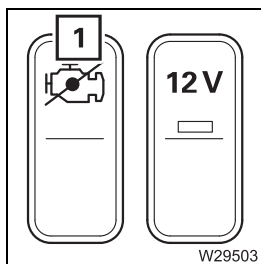

The engine torque is reduced.

- Push the button (1) upwards to override the torque reduction.

You can override torque reduction up to 3 times.

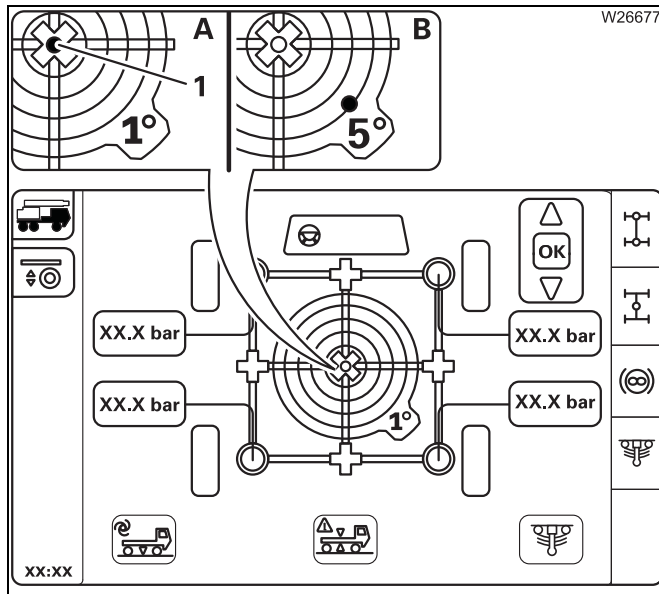

(A) – When the truck crane is level the marking (1) is in the middle.

(B) – In this example, the carrier would be standing higher to the rear on the right hand side.

### Exiting the menu

You can exit the *Suspension/Level adjustment system* menu at any time.

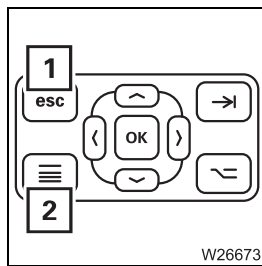

- Press the button (1) once.

The Start menu opens.

or

- Press the button (2) once.

The next highest menu is opened.

The *Suspension/Level adjustment system* menu automatically closes as soon as the current speed rises above approx. 5 km/h .

## Examples

This section only contains examples of the settings.

Always adjust the setting to the current conditions (warm, cold, damp).

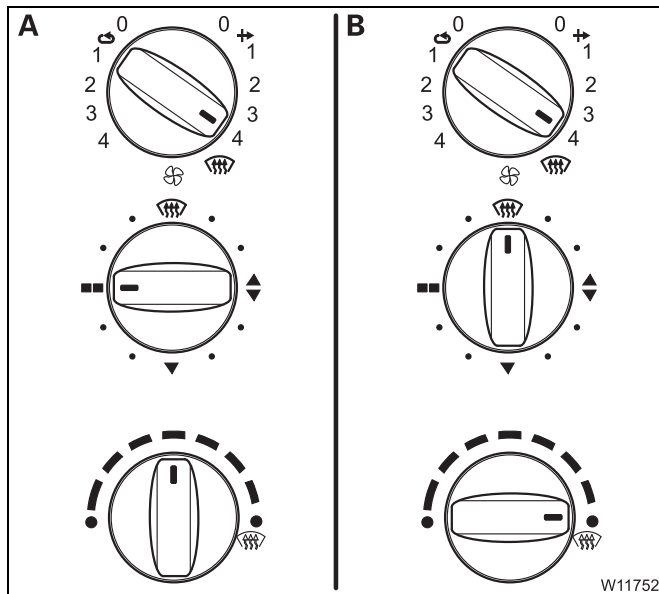

### (A) – Ventilate

- Turn the switches to the positions shown.
- If necessary, open the air vents for the side and centre.

### (B) – Defrosting the windscreen

- Turn the switches to the positions shown.
- Close the air vents for the side and centre.

## Switching off

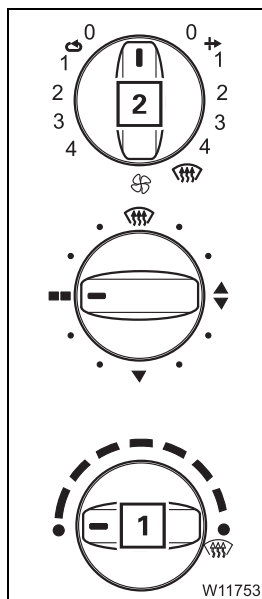

### Switching off the heating system

- Turn the switch (1) as far as it will go in a counter-clockwise direction, to *Cold*.

### Switching off the ventilation

- Turn the switch (2) to the level 0.

## 5.6.4

### Auxiliary air heater

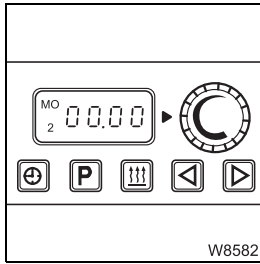

You can use the auxiliary air heating to preheat the driver's cab or provide additional heating.

The batteries will be drained if you operate the auxiliary heater with the engine switched off. You must recharge the batteries at shorter intervals if you use the auxiliary heater frequently!

#### Switching on

To switch the auxiliary heater on and off, you can:

- Switch the auxiliary heater on and off manually; the ignition must be switched on for this.
- or set an automatic heating start and heating period with the timer;
  - ▮▮▮▮ *Other functions*, p. 5 - 76.
- Before switching on the heating system, check whether it is allowed to be operated at the current location of the truck crane. Find out whether there are any possible sources of danger that could result in an explosion.



#### Risk of explosion when operating the heating system!

The heating system may not be operated:

- at service stations and tank farms,
- at places where flammable gases or vapours can be found or formed (e.g. at places where fuel is stored and in chemical factories),
- at places where explosive dust can be found or formed (e.g. carbon dust, wood dust and grain dust).



#### Risk of suffocation when operating the heating system!

Do not operate the heating system or the heating system with the timer in enclosed rooms (e.g. garages).

- Switch on the ignition; ▮▮▮▮ *Switch on the ignition*, p. 4 - 11.
- Press the button (1) once.  
The auxiliary heater switches on automatically – the control field lights up.

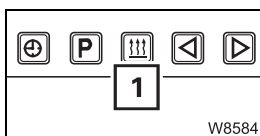

## 6.1.2

### Tables for a maximum axle load of 12 t



This section only shows some standard driving modes. For further information on additional or individual driving modes, please contact **Manitowoc Crane Care**.



If you remove indicated parts from the truck crane in driving mode, then the total weight decreases but can be distributed in such a way that the front or rear axle loads are over 12 t .



The following applies to all driving modes:  
The counterweight is completely unrigged.

Also be aware of the effects on the axle loads when towing a trailer;  
▣▶ p. 5 - 77.





## 6.3

### Rigging work for driving with a dolly

To reduce the axle loads to the specifications applicable in the country in which you are working, you can set the main boom onto a dolly when driving.

For this purpose, the truck crane must be fitted with a slewing gear free-wheel, boom floating position and if necessary, with a boom pre-tensioning device.

Before driving with the dolly, you must:

- Switch on the slewing gear freewheel;  p. 6 - 14,
- Switch on the boom floating position;  p. 6 - 15,
- Switch on boom pre-tensioning, if necessary;  p. 6 - 16.

### 6.4.4

## Retracting/fitting the derricking cylinder head pin

The derricking cylinder head axle is retracted and fitted with a pulling device.

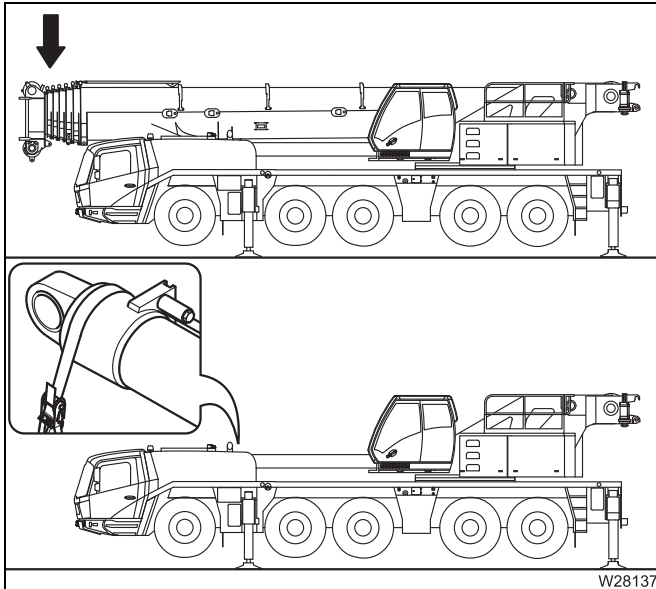

You must lower the main boom onto the main boom rest before pulling off the head pin.

When the main boom is unrigged then the derricking cylinder is fastened to the main boom rest and secured using a tightening belt.

### Operating the lifting device



A lifting device is needed in order to relieve and level the derricking cylinder.

#### Danger from using unsuitable lifting device

Have the lifting device serviced in time before the maintenance interval specified on the label expires.

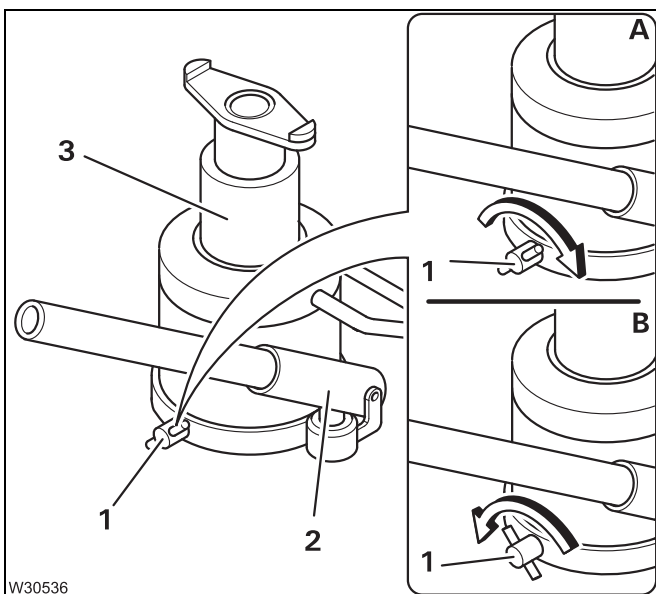

- Attach the lever to the holder (2).

(A) – Raise

- Close the drain plug (1) and pump the lever. The piston rod (3) extends.

(B) – Lowering

- Slowly open the drain plug (1). The piston rod (3) retracts.



## 6.4.9

### Transporting the main boom

Transport the main boom only on a separate vehicle which is of sufficient size and has sufficient lifting capacity.

Transport dimensions and weight;  *Operating Instructions*.

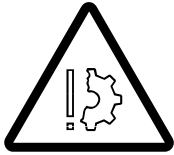

#### **Risk of damage to the main boom!**

Always place the main boom onto a suitable packing. If you lay the main boom on its side, add-on parts will be damaged.

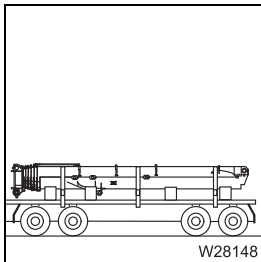

- Always place the main boom onto a suitable packing!
- Secure the main boom against slipping using the holding ropes.
- Load the main boom in such a way that other road users are not put at risk.
- Load the transport vehicle in such a way that the weight is evenly distributed.
- Secure the connection lines so that they will not slip and be damaged during transport.
- Keep the connecting points free of contamination.

## 6.5.6

### Disconnecting/establishing hydraulic connection

There is a valve block on each outrigger beam. The position of the valve block may differ from the drawings, depending on the outrigger beam.

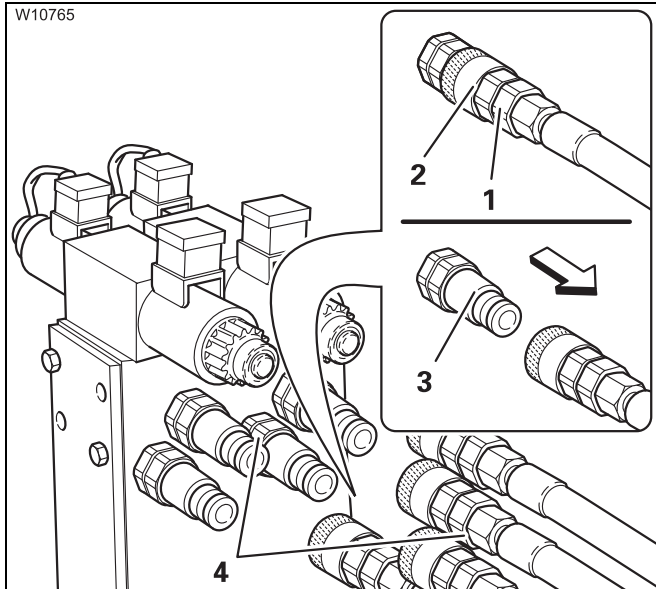

#### Disconnecting a connection

Always disconnect all connections (4).

- Hold the hose (1) firmly.
- Pull the lock (2) against the stop. The hose is pushed out of the connection (3).
- Seal all connecting points.

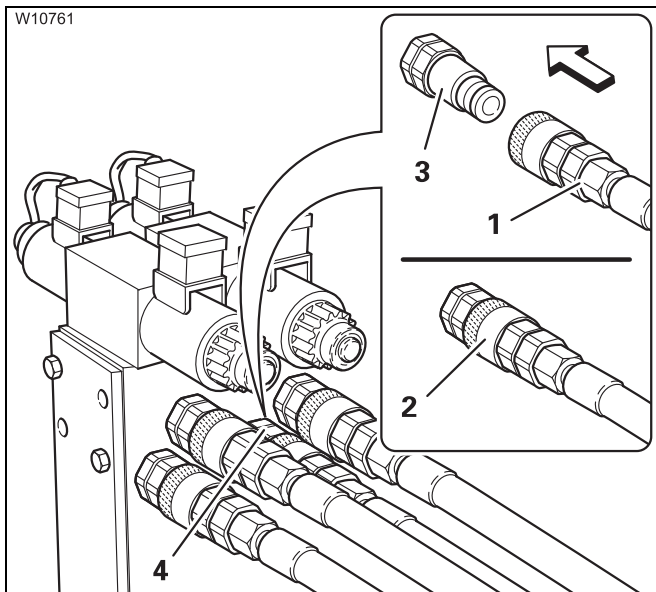

#### Establishing a connection

Always establish all connections (4).

The assignment is specified by colour designations.

- Insert the hose (1) into the connection (3).
- The lock (2) engages.

## 6.6

### Rigging the auxiliary hoist

You need the following equipment:



- suitable lifting gear and guide ropes with sufficient bearing capacity,
- a separate vehicle,
- if necessary, a rigging frame for rigging counterweight combinations up to max. 21 t.

Transport dimensions and weights;  p. 1 - 10.

### 6.6.1

#### CHECKLIST: Installing the auxiliary hoist

##### Prerequisites

- The truck crane is supported with the required outrigger span as specified in the *lifting capacity table*;  p. 11 - 28.
- The 50 t counterweight combination is resting on the counterweight platform;  p. 11 - 76,  
or for a maximum of 21 t counterweight:

1. Sling and position the rigging frame;  p. 6 - 57.

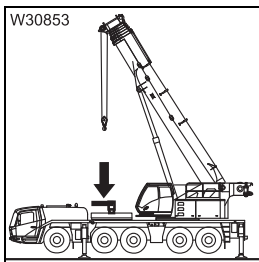

2. Sling the auxiliary hoist at the centre of gravity;  p. 6 - 57.

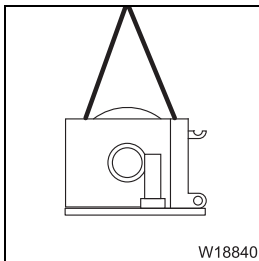

3. Lower the auxiliary hoist to:

- the counterweight combination  
or
- the rigging frame;  p. 6 - 58.

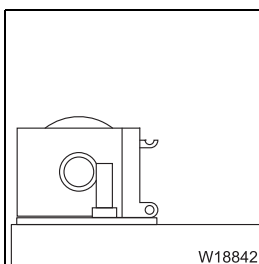

### Disconnecting a connection

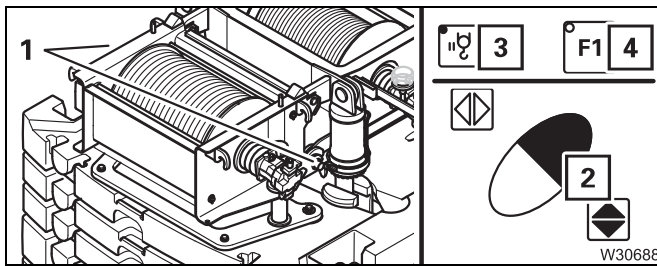

### Lowering the lifting frame

- Press the buttons (3) and (4).
- Press the buttons (2) until the locking points (1) are relieved.

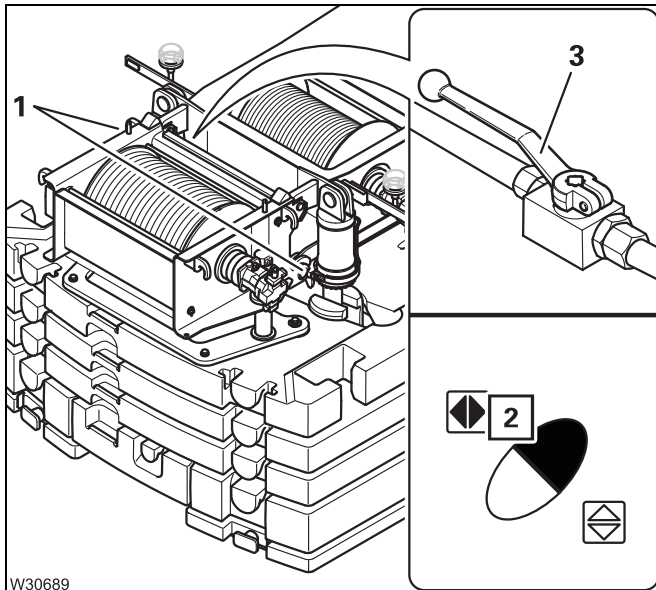

### Retracting the locking cylinders

- Open the safety valve (3) – lever parallel with the line.

- Press the button (2) until the locking cylinders (1) are fully extended.

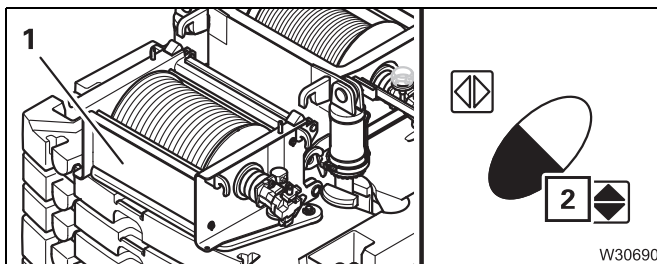

### Lowering the auxiliary hoist

- Press the button (2) until the auxiliary hoist (1) is completely lowered.

## 7.3

## Warning and error messages

### Program version

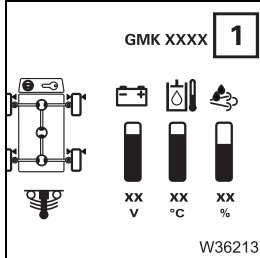

- Always note down the number of the program version and the serial number after a malfunction occurs before notifying **Manitowoc Crane Care**.

The serial number (1) is shown in the Start menu.

The program version is displayed in the crane cab;  p. 14 - 3.

### 7.3.1

### Warning or malfunction messages on the instrument panel

#### Meaning of the lamps

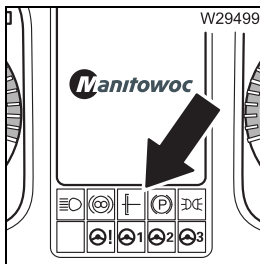

The colour of the lamps indicates whether a warning or malfunction message is active in the corresponding area.

- Lamp goes out – no message.
- Lamp is **red** – warning message.
  - Stop the truck crane immediately, taking into account the traffic situation, and identify the cause!
- Lamp is **orange** – malfunction message.
  - Identify the cause at the next opportunity.

If a symbol is displayed in **red** perform the following checks.



**Risk of damage if warning or malfunction messages are not heeded!**  
Observe the following information promptly and take the appropriate corrective measures if a warning or malfunction message appears. This prevents these malfunctions causing defects in the truck crane.

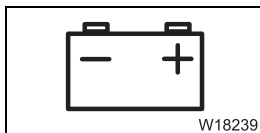

#### Battery charge indicator warning

The voltage in the carrier electrical system is too high or too low.  
Current voltage display;  *Monitoring elements*, p. 4 - 19.



## 7.3.4 Engine/transmission error messages

### Open menu

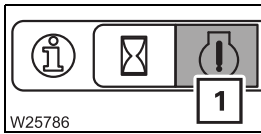

- Open the *Errors* menu (1).

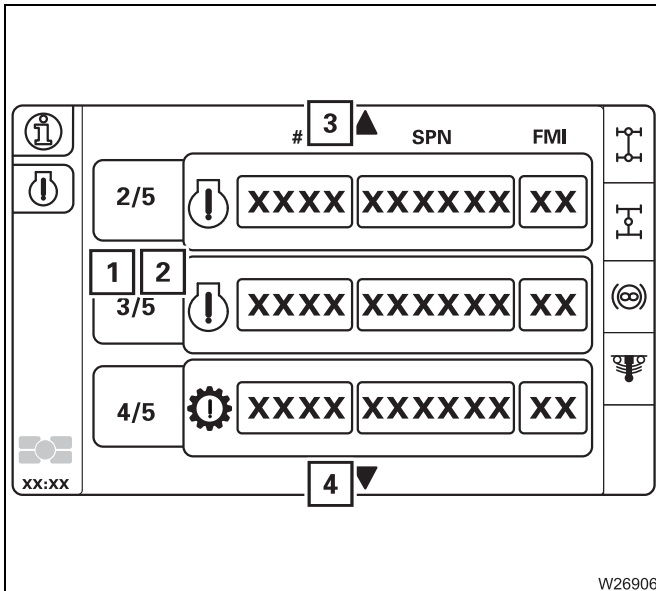

### Display of error / total errors

Display (2) shows the error total, and display (1) shows which error is displayed.

**3/5**, for example, means:

- The error **3** is shown,
- There is a total of **5** errors.

### Displaying errors

- Select and acknowledge the symbol (3) or (4) to show any additional errors.

- 3** Next error
- 4** Previous error

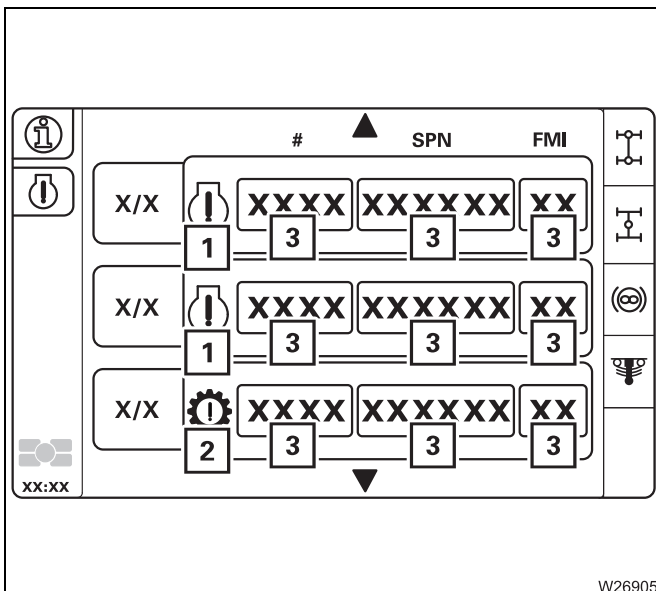

### Error message display

For each error the display shows:

- the error code (3),
- The symbols for the faulty components:
  - 1** Engine
  - 2** Transmission

- Always note the error code before contacting **Manitowoc Crane Care**.

### Exiting the menu

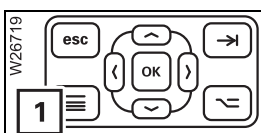

You can exit the *Engine errors* menu at any time.

- Press the button (1) once.

The next highest menu is opened.

## 7.5

## Emergency operation and breakdown assistance

### 7.5.1

### Externally starting the truck crane

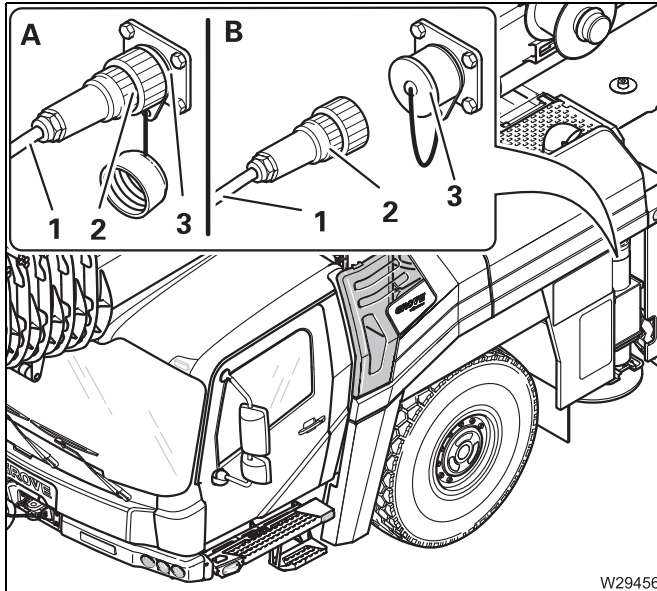



- Start the engine of the auxiliary vehicle.
- **(A)** – Connect the cable (1) to the auxiliary vehicle's power supply (24 V).
- Insert the plug (2) into the socket (3).
- Start the truck crane engine.
- **(B)** – Pull out the plug (2).
- Close the socket (3).
- Remove the cable (1) from the auxiliary vehicle.

The socket (3) can also be used as a power source for another vehicle (with a 24 V on-board network).

### Inflating the tyres

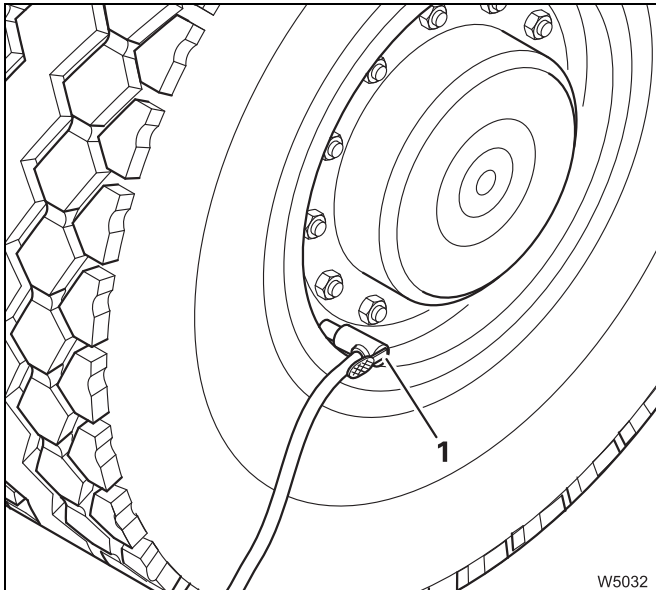
The maximum operation pressure of the compressed air system of 8 bar can only be reached with the engine running.



- Start the engine;  p. 4 - 14.
- Fasten the tyre connection (1) to the tyre valve.
- Press the button on the tyre connection and inflate the tyre.
- Disconnect the tyre connection (1) from the tyre valve.

### Remove the filling hose

Before driving, you must remove the filling hose from the filler connection.

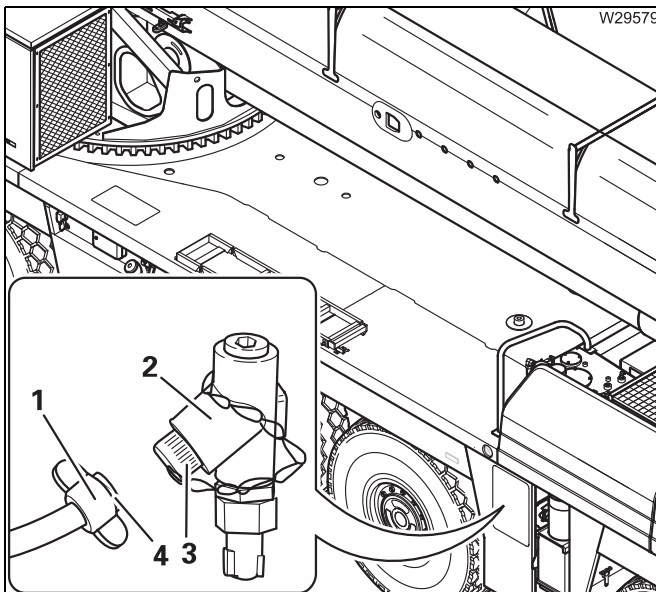

- Remove the connection (1) from the filler connection (2).
- Close the filler connection and the connection with the caps (3) and (4).
- Stow the filling hose away.
- Drive to a service station or repair shop and adjust the tyre pressure.



#### **Risk of damage to the compressed air system!**

Always close the filler connection with the cap.

This prevents damage to the compressed air system and contamination of it.

<b>1</b>	– Camera on main boom <sup>1)</sup>	➡ p. 11 - 133
	– Camera on the hoists	➡ p. 11 - 135
	– Camera on the driver's cab <sup>1)</sup>	➡ p. 11 - 135
<b>2</b>	Anemometer and air traffic control light <sup>1)</sup>	➡ p. 11 - 122
<b>3</b>	Lifting limit switch – function	➡ p. 10 - 82
	Lifting limit switch – rigging	➡ p. 11 - 116
<b>4</b>	Socket for hand-held control	➡ p. 8 - 77
<b>5</b>	Sleuable spotlight <sup>1)</sup>	➡ p. 10 - 127
<b>6</b>	Rigging the main boom <sup>1)</sup>	➡ p. 6 - 17
<b>7</b>	RCL override – Version A <sup>3)</sup>	
	– Key-operated switch for overriding the RCL in an emergency	➡ p. 8 - 137
	RCL override – Version B <sup>3)</sup>	
	– No function	➡ p. 8 - 138
<b>8</b>	Spotlights <sup>1)</sup>	➡ p. 8 - 8
<b>9</b>	Status display RCL	➡ p. 10 - 63
<b>10</b>	Hydraulic emergency operation	➡ p. 14 - 47
	Hydraulic emergency operation as per BGR 159 <sup>1)</sup>	➡ p. 14 - 51
<b>11</b>	Lowering limit switch	➡ p. 10 - 84
<b>12</b>	Counterweight, removed	➡ p. 11 - 67
<b>13</b>	Shut-off valves on the superstructure hydraulics	➡ p. 9 - 3
<b>14</b>	Outrigger	
	– Operation	➡ p. 11 - 37
	– Lighting	➡ p. 3 - 70
	– Installing/removing the outrigger beams	➡ p. 6 - 35
<b>15</b>	– Fuel tank auxiliary heater	➡ p. 10 - 5
	– Storage compartment for anemometer	➡ p. 11 - 122
<b>16</b>	Drive unit <sup>2)</sup>	
<b>17</b>	Slewing gear	
	– Operation	➡ p. 10 - 115
	– Turntable lock	➡ p. 8 - 124
	– Switching on the slewing gear freewheel <sup>1)</sup>	➡ p. 6 - 14
	– Switching off the slewing gear freewheel	➡ p. 11 - 18

<sup>1)</sup> Additional equipment

<sup>2)</sup> ➡ *Maintenance Manual*

<sup>3)</sup> Version A or version B active depending on RCL programming



Right

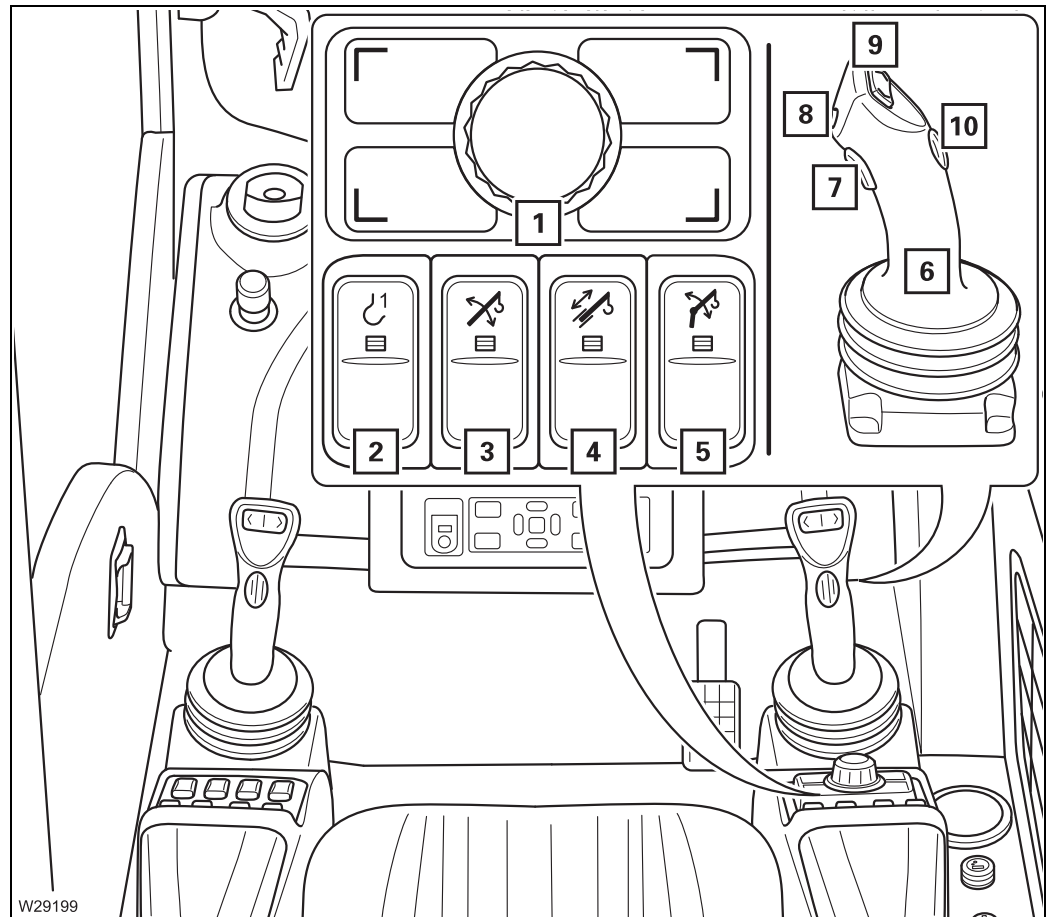

W29199

- |  |                 |
|--|-----------------|
| <b>1</b> Jog dial (rotary push button)                               | ▣▣▣▣ p. 8 - 89  |
| <b>2</b> Main hoist on/off   | ▣▣▣▣ p. 8 - 109 |
| <b>3</b> Derricking gear on/off                                      | ▣▣▣▣ p. 8 - 115 |
| <b>4</b> Telescoping mechanism on/off                                | ▣▣▣▣ p. 8 - 117 |
| <b>5</b> Derrick lattice extension on/off <sup>1), 2)</sup>          |                 |
| <b>6</b> Right-hand control lever (configuration depends on version) | ▣▣▣▣ p. 8 - 14  |
| <b>7</b> Dead man's switch   | ▣▣▣▣ p. 8 - 88  |
| <b>8</b> Horn button   |                 |
| <b>9</b> Hoist high-speed mode on/off                                | ▣▣▣▣ p. 8 - 109 |
| <b>10</b> Main hoist slewing indicator                               | ▣▣▣▣ p. 10 - 76 |

1) Additional equipment

2) ▣▣▣▣ *Operating Instructions Lattice Extension*

- 1 Superstructure menu group** ▶▶▶▶ p. 8 - 26
  - Superstructure lock sub-menu
  - Counterweight menu
- 2 Outrigger menu group** ▶▶▶▶ p. 8 - 29
  - Outrigger cylinders menu
  - Outrigger menu
- 3 RCL/Telescoping menu group** ▶▶▶▶ p. 8 - 33
  - Enter rigging mode/telescope status menu
  - Lifting capacity tables menu
  - Telescoping semi-automation menu
  - Manual telescoping menu
- 4 Working range limiter menu group** ▶▶▶▶ p. 8 - 43
  - Overall height menu
  - Working radius menu
  - Slewing angle menu
  - Hoist rope travel limitation menu
- 5 Information 1 menu group** ▶▶▶▶ p. 8 - 48
  - Hydraulic pressure and fuel consumption menu
  - Datalogger menu
- 6 Heating/Engine/Additional equipment menu group** ▶▶▶▶ p. 8 - 51
  - Economy menu
  - Remote control menu<sup>1)</sup>
  - Heating/air-conditioning menu
  - Spotlights menu<sup>1)</sup>
- 7 Telescoping emergency program menu group** ▶▶▶▶ p. 8 - 56
  - Telescoping emergency program menu
  - Unknown telescoping menu
  - Swinging the swing-away lattice emergency operation menu<sup>2)</sup>

1) Additional equipment

2) Additional equipment GMK5250L



## 8.1.11 RCL/Telescoping menu group

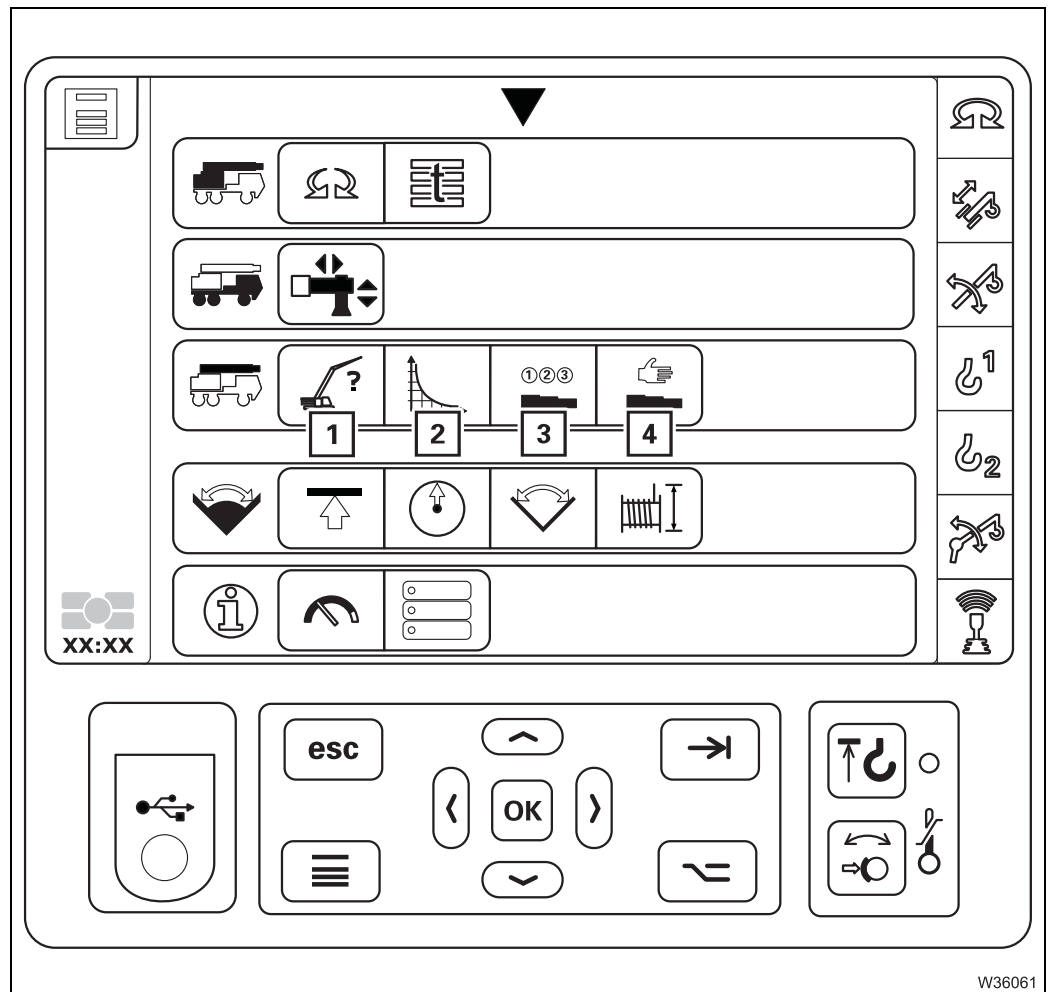

- |   |       |           |
|---|-------|-----------|
| <b>1</b> Enter rigging mode/telescope status menu | ▣▣▣▣▶ | p. 8 - 34 |
| <b>2</b> Lifting capacity tables menu             | ▣▣▣▣▶ | p. 8 - 40 |
| <b>3</b> Telescoping semi-automation menu         | ▣▣▣▣▶ | p. 8 - 41 |
| <b>4</b> Manual telescoping menu                  | ▣▣▣▣▶ | p. 8 - 42 |



## 8.1.12 Working range limiter menu group

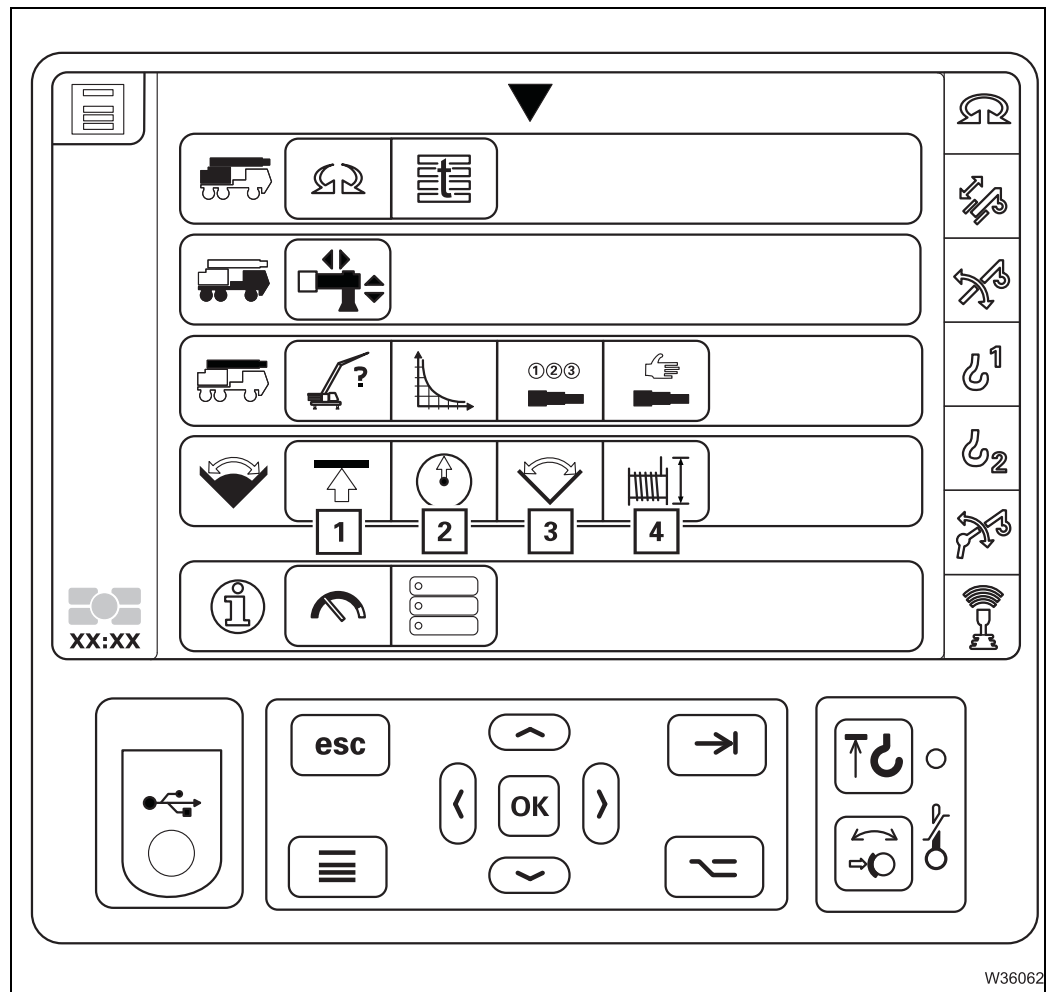

- |  |                |
|--|----------------|
| <b>1</b> Overall height menu               | ▣▣▣▣ p. 8 - 44 |
| <b>2</b> Working radius menu               | ▣▣▣▣ p. 8 - 45 |
| <b>3</b> Slewing angle menu                | ▣▣▣▣ p. 8 - 46 |
| <b>4</b> Hoist rope travel limitation menu | ▣▣▣▣ p. 8 - 47 |



## Remote control menu

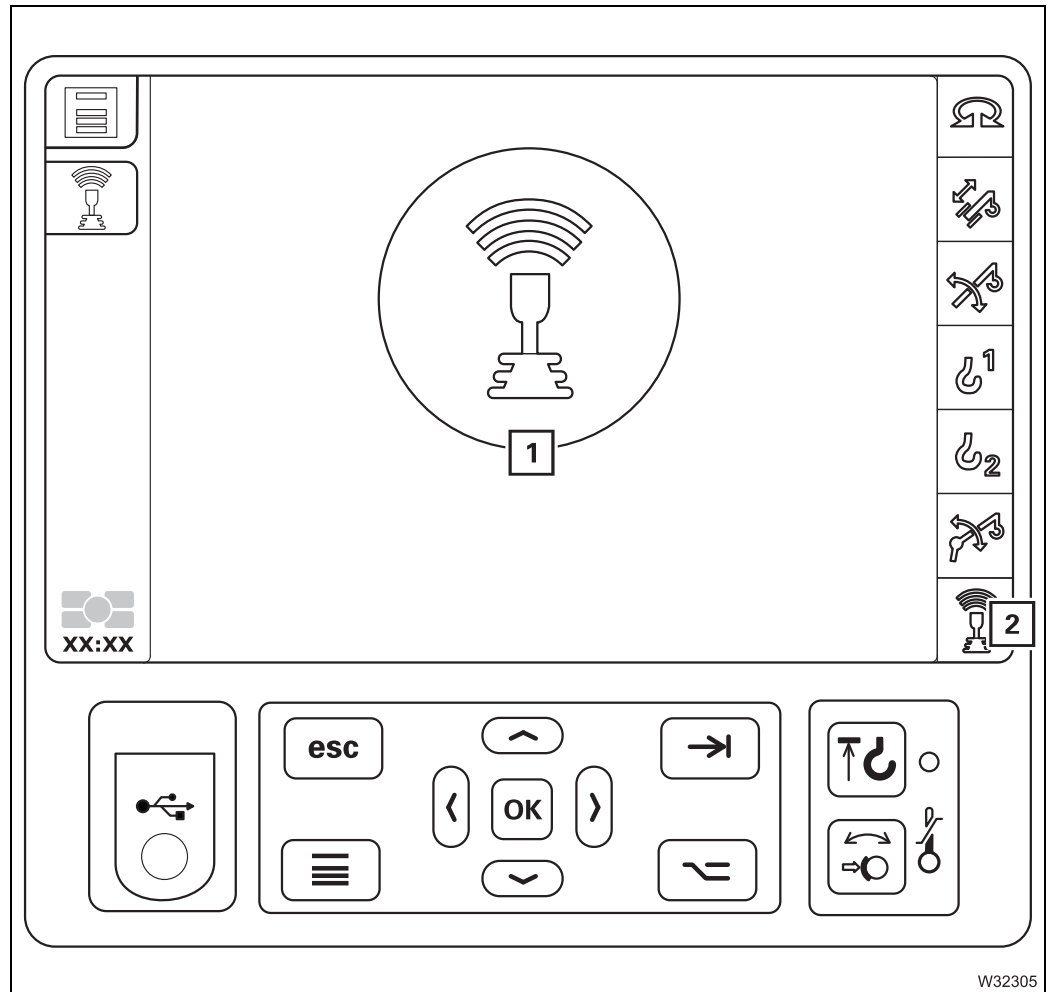

- 1 Remote control menu
- 2 Remote control display

▣▣▣▣ p. 8 - 126

▣▣▣▣ p. 8 - 126



## Switch units menu

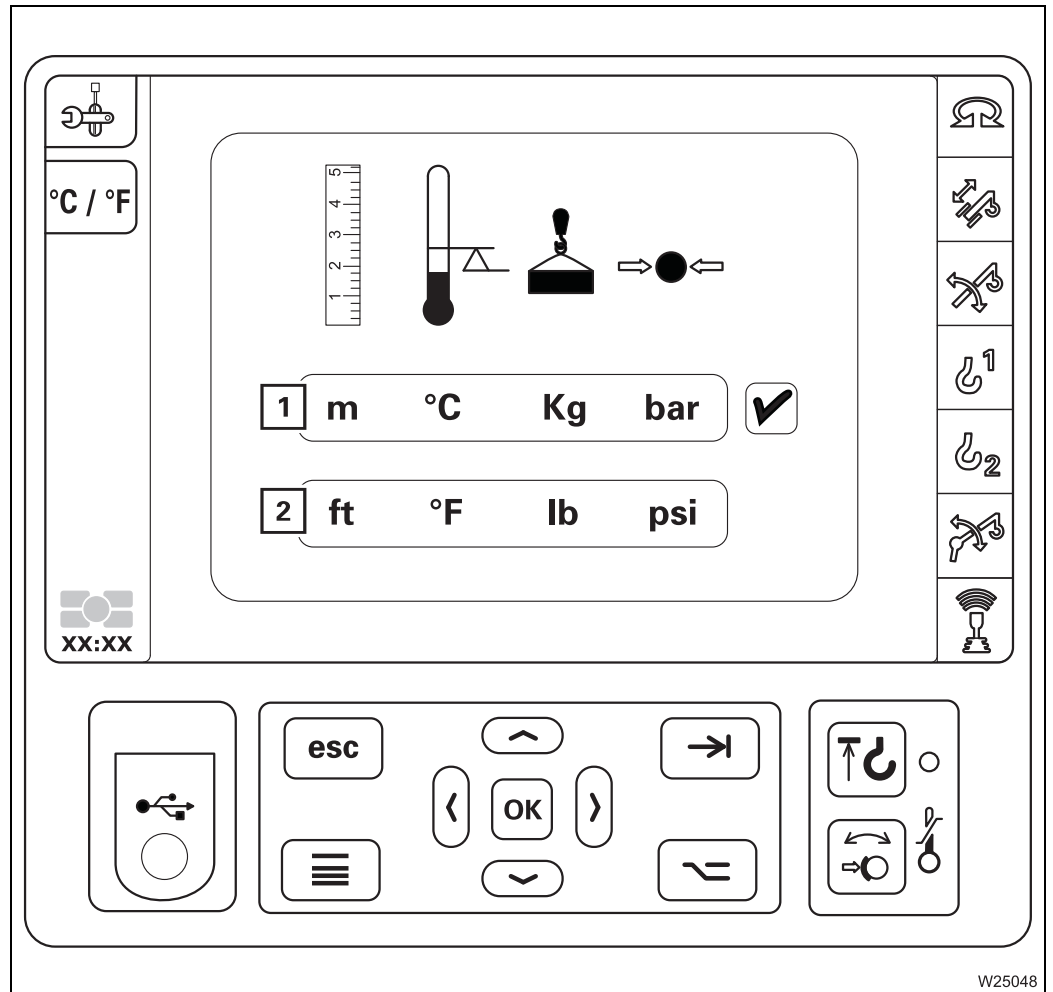

- 1 Display units in:
  - Metres
  - Degrees Celsius
  - Kilograms
  - Bar

▶▶▶ p. 10 - 125

- 2 Display units in:
  - Feet
  - Degrees Fahrenheit
  - lbs
  - Psi



CLICK HERE TO **DOWNLOAD** THE COMPLETE MANUAL

- Thank you very much for reading the preview of the manual.
- You can download the complete manual from: [www.heydownloads.com](http://www.heydownloads.com) by clicking the link below



- Please note: If there is no response to CLICKING the link, please download this PDF first and then click on it.

CLICK HERE TO **DOWNLOAD** THE COMPLETE MANUAL

## 8.1.20 Menu-independent displays

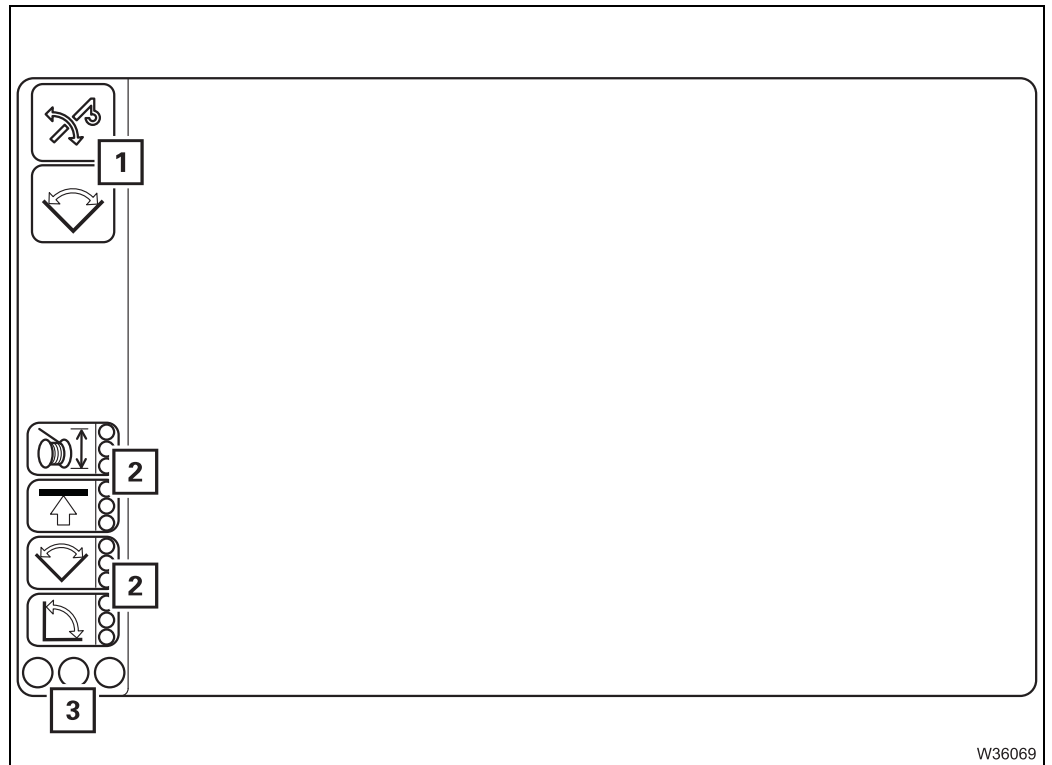

1 Warning messages display

▮▮▮ p. 14 - 9

2 Working range limiter displays

▮▮▮ p. 10 - 132

3 RCL status display

▮▮▮ p. 10 - 51

## 8.2

## Brief description of the operating elements



### Risk of accidents through operating error!

This section is not a complete operating manual. It only provides a general overview of the functionality of the operating elements.

Before using the operating elements for the first time, read through the following chapters and the safety instructions listed there.

This section does not contain all the requirements that must be fulfilled for several operating elements to be active.

If some operating elements do not work, first read the following chapters referred to at the respective places before contacting **Manitowoc Crane Care**.

### 8.2.1

### Definition of direction information

#### Basic rule

Direction information always depends on whether the carrier or the superstructure is being operated.

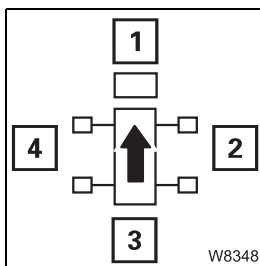

#### On the carrier

The driver's cab is always at the front, which means that:

- |          |          |
|----------|----------|
| 1: front | 2: Right |
| 3: rear  | 4: Left  |

**Forwards** always means with driver's cab leading,

**Backwards** always means the rear lights on the carrier are to the front.

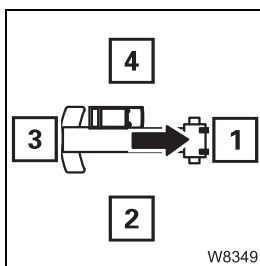

#### On the superstructure

The main boom head is always at the front, which means that:

- |          |          |
|----------|----------|
| 1: front | 2: Right |
| 3: rear  | 4: Left  |

#### Switches

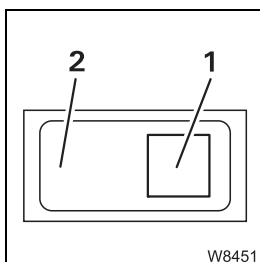

For switches and buttons, the terms **bottom** and **top** are used.

Regardless of the fitting position (vertical, horizontal, diagonal, perpendicular or turned), the following always applies:

- **Down:** press in at (1) – next to the symbol
- **Up:** press in at (2) – opposite the symbol

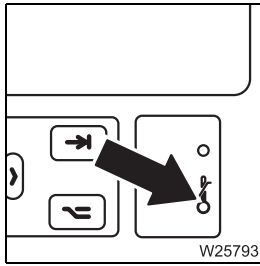

### Display temperature warning display

The temperature of the control unit is measured by an internal sensor.

- **blue, flashing:** Temperature too low – display will not be switched on
- Temperature too high:
- **red, lights up:** Brightness is reduced
- **yellow, flashing:** Display is switched off
- **red, flashing:** Control unit is switched off

▣▣▣▣ Temperature on the display, p. 10 - 31

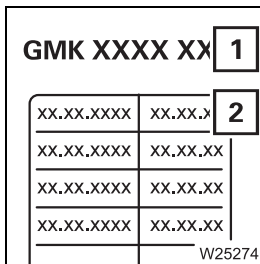

### Serial number and programme version display

- 1 Truck crane serial number
- 2 Current program version of the crane control – always include in the event of a malfunction; ▣▣▣▣ p. 14 - 3

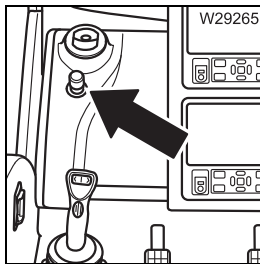

### Emergency stop switch

May only be used in an emergency.

- **Press:** Engine off – crane functions stop immediately.  
Switch latches
- **Turn engaged switch:** Switch returns to initial position – crane functions released

▣▣▣▣ p. 9 - 10

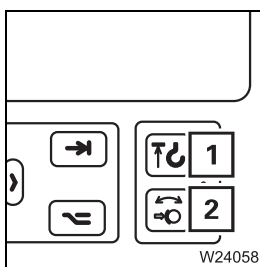

### Other

- 1 Lifting limit switch warning; ▣▣▣▣ p. 8 - 110
- 2 Slewing gear brake indicator lamp; ▣▣▣▣ p. 8 - 114

## 8.2.11 Inclination indicators

▣▣▣▣ ▣ Inclination indicators, p. 11 - 58

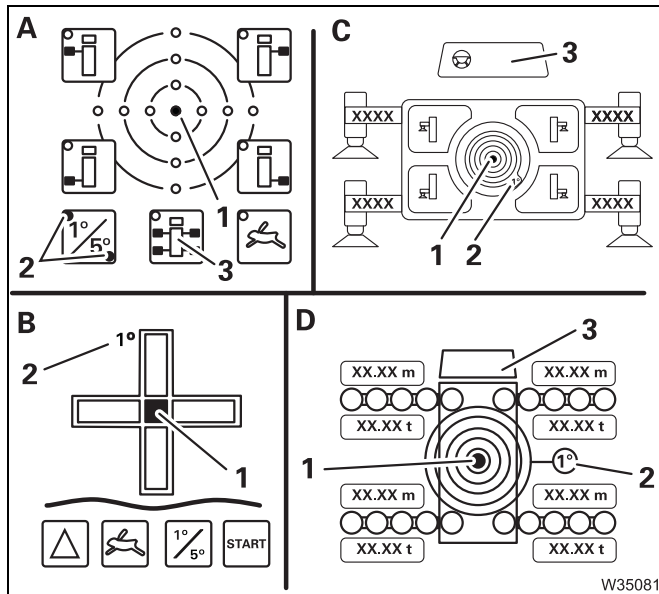

### Current inclination display

- A On the hand-held control
- B On the *outrigger control units*
- C In the *Outrigger menu*
- D In the Monitoring menu

- 1 Inclination indicator
- 2 Measuring range display
- 3 Directional indicator

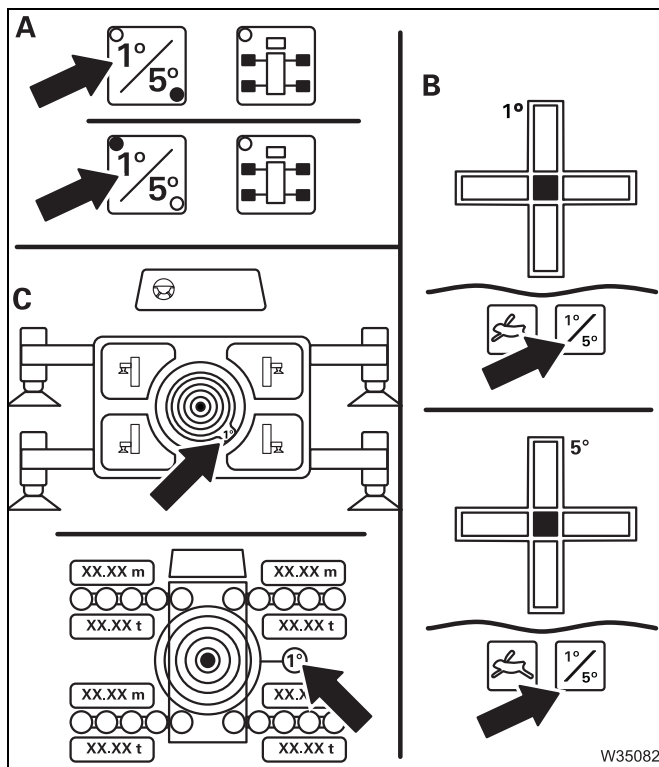

### Switch over measuring range

- A On the hand-held control  
Press button once – lamp for current measuring range 1° or 5° lights up
- B On the *outrigger control units*  
Press button once – the current measuring range 1° or 5° is shown
- C In the *Outrigger* and *Monitoring* menus – automatically switched over

## 8.2.17

### Slewing gear

▣▣▣▣▶ *Slewing gear*, p. 10 - 115.

#### Control panels

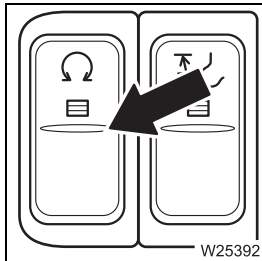

#### Slewing gear on/off

There is a lamp in the button.

- **Press once:**
  - Lamp bright – slewing gear on,  
Slewing gear brake released
  - Lamp dim – slewing gear off  
Slewing gear brake applied

▣▣▣▣▶ p. 10 - 115

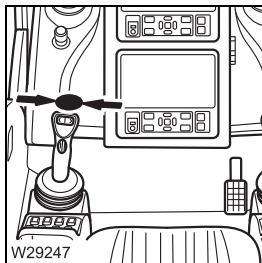

#### Left control lever

- **To the left:** Slew to the left
- **To the right:** Slew to the right

▣▣▣▣▶ p. 10 - 116



#### Slewing gear freewheel

- Slewing gear is switched on.
- The control lever (2) is in the initial position.
- **To switch on:** Press button (3) or (4) – slewing gear brake released, lamp (1) goes out
- **To switch off:** Release button – slewing gear brake applied, lamp (1) lights up

▣▣▣▣▶ p. 10 - 119



## 8.2.20

### Hydraulic system

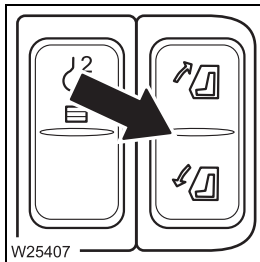

#### Inclining the crane cab

- **Press down:** incline to the front
  - **Press up:** incline to the rear
- ▮▮▮▮▶ p. 10 - 121

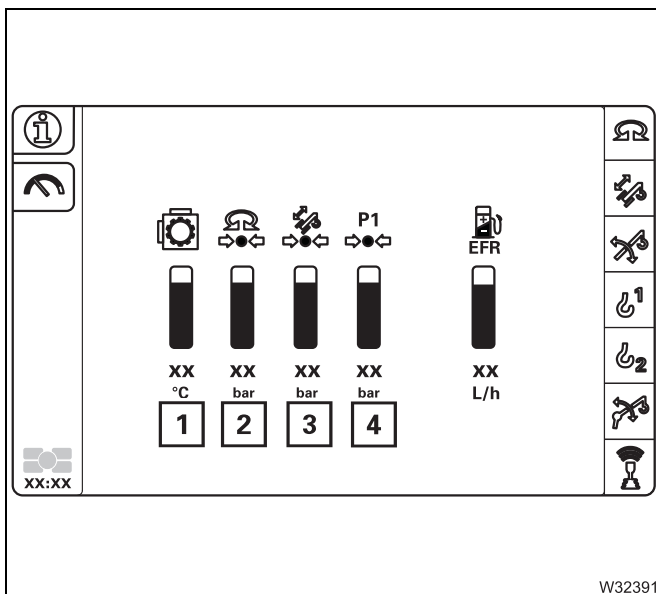

#### In Information menu

- 1 Angle gear oil temperature

Current pressure in bar for movements of:

- 2 Slewing gear
- 3 Telescoping mechanism
- 4 – Hoist
  - Derricking gear
  - Counterweight hoist unit
  - Inclining the crane cab
  - Locking units

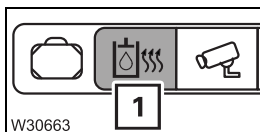

#### Preheating the hydraulic oil

- **To switch on:** Select symbol (1) and confirm – symbol is **red**
  - **To switch off:** Select symbol (1) and confirm – symbol is **grey**
- ▮▮▮▮▶ p. 10 - 14



### Accept the measured outrigger span

Select and confirm – the outrigger span provided by the outrigger width monitoring is adopted and shown on the *Enter outrigger span* display;  
 ■■■► *Confirm the rigging mode and lifting capacity table, p. 10 - 41.*

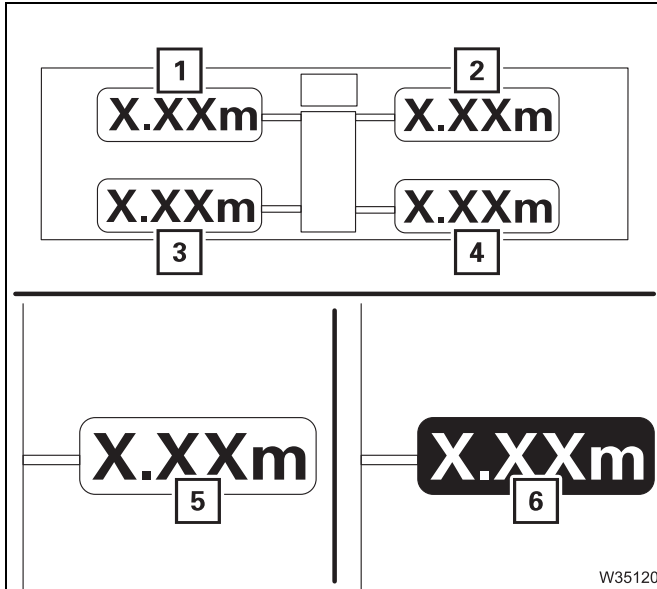

### Enter outrigger span (MAXbase)

The values are entered individually for outrigger beams (1) to (4).

In input mode – select and confirm the individual widths.

### Outrigger span monitoring display (MAXbase)

- 5 Measured outrigger width = required width
- 6 Measured outrigger width  $\neq$  of required width

■■■► *Enter rigging mode, p. 10 - 32*

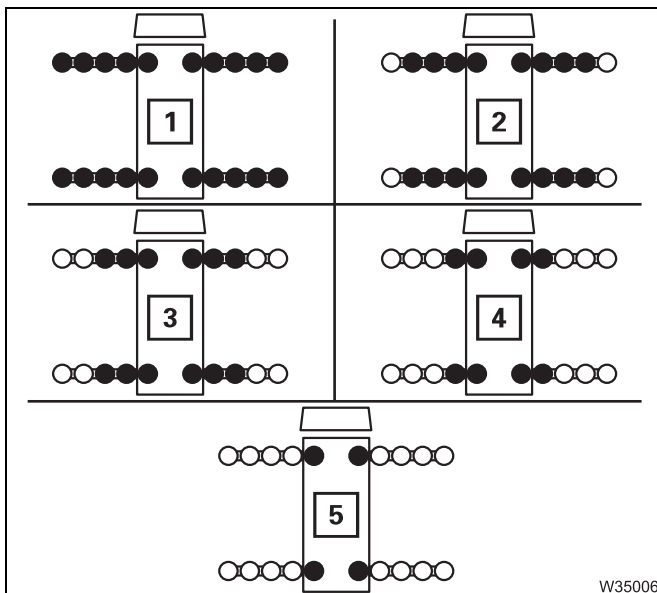

### Enter outrigger span (Standard)

The selection occurs simultaneously for all outrigger beams – selected outrigger widths are orange.

In input mode – select and confirm the outrigger span

- 1 8.950 x 7.800 m
- 2 8.950 x 6.854 m
- 3 8.950 x 5.910 m
- 4 8.950 x 4.310 m
- 5 8.950 x 2.710 m

■■■► *Enter rigging mode, p. 10 - 32*



## 8.2.26

### Hand-held control

#### Sockets for hand-held control

The following applies to all sockets:

- Pull plug: Engine off – ignition off
- Insert plug: Ignition on

▣ p. 11 - 21

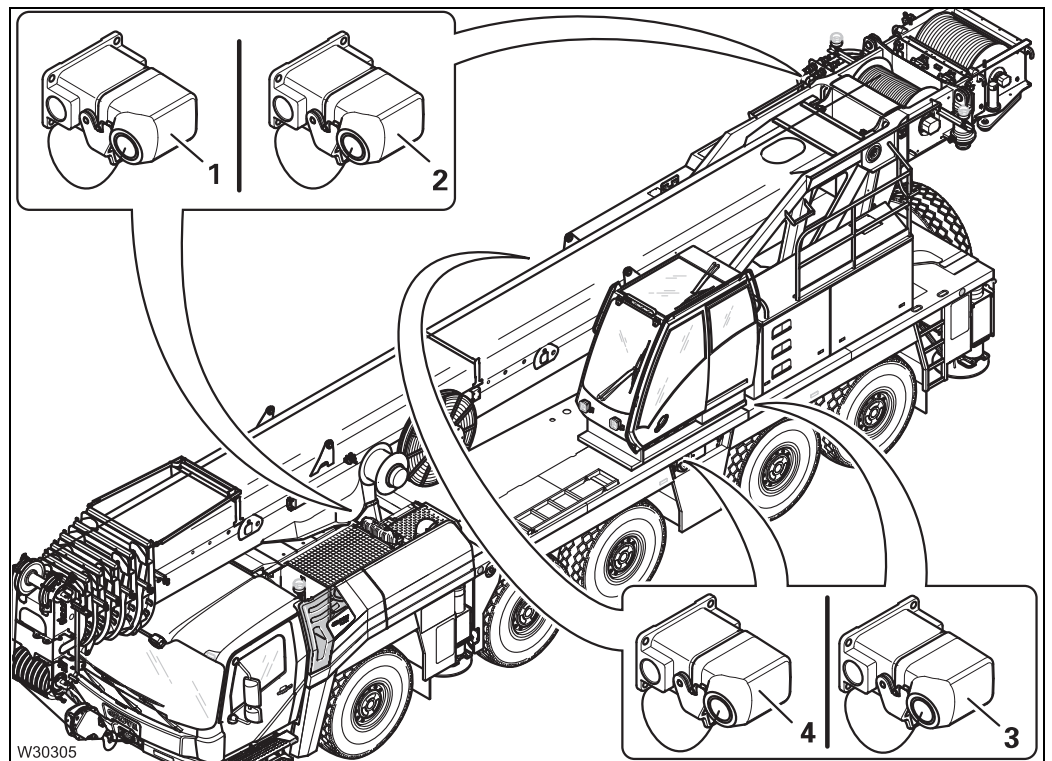

The hand-held control is only active when it is connected to the sockets (1) to (4).

Released operations	
<b>1</b>	<ul style="list-style-type: none"> <li>– Emergency operation for crane movements (except for telescoping mechanism)</li> <li>– Derrick lattice extension<sup>1)</sup></li> </ul>
<b>2</b>	<ul style="list-style-type: none"> <li>– Rig auxiliary hoist<sup>1)</sup></li> </ul>
<b>3</b>	<ul style="list-style-type: none"> <li>– Emergency operation for crane movements</li> </ul>
<b>4</b>	<ul style="list-style-type: none"> <li>– Operation of the outriggers</li> </ul>

<sup>1)</sup> Additional equipment



## 9.1.2

### Checks before starting the engine

#### At the hydraulic tank

The valve on the hydraulic tank must be open before starting the engine.



#### **Risk of damage to the hydraulic pumps!**

You may only start the engine when the valve on the hydraulic tank is open!

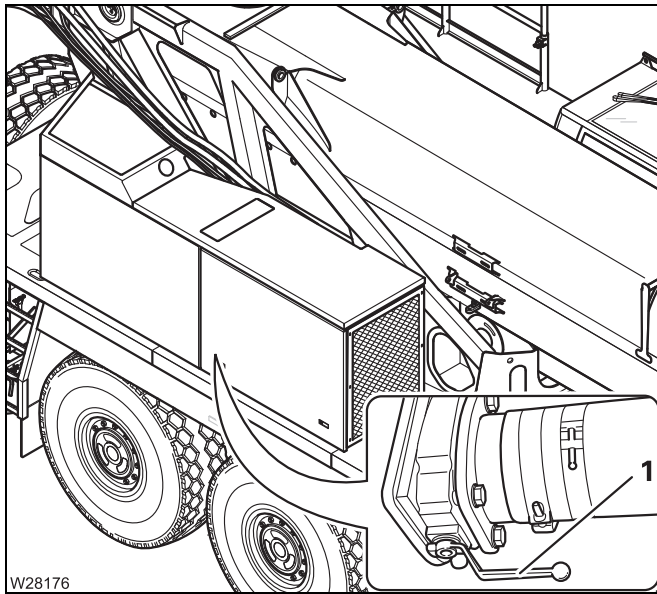

- Check that the valve is open – lever (1) parallel to the pipe.
- Open the closed valve.



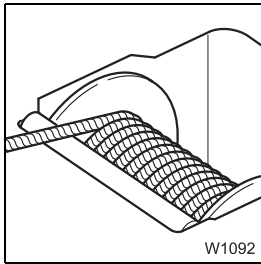

9. Check the position of the hoist ropes; ■■■▶ p. 10 - 6.

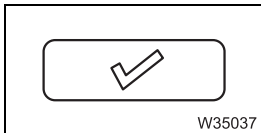

10. Compare current rigging mode with the *RCL* display – enter and confirm current rigging mode, if necessary; ■■■▶ p. 10 - 30.

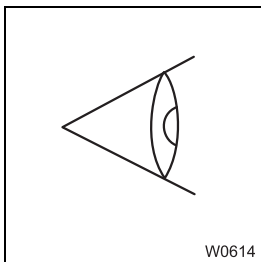

11. Check the telescope status; ■■■▶ *Checks before starting work*, p. 10 - 96.

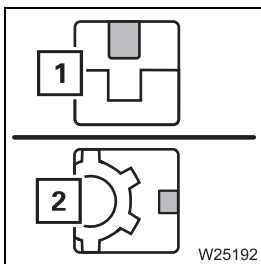

12. – Switch off the slewing gear for 0° and 180° working positions – symbol (1) **red**; ■■■▶ p. 10 - 119.

– Switch off houselock for other working positions – symbol (2) is **red**; ■■■▶ p. 10 - 19.

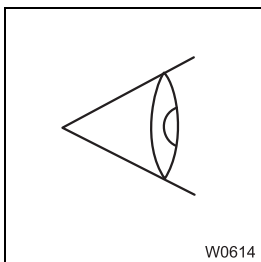

13. Check the electrical system for correct operation; ■■■▶ p. 10 - 7.



## 10.1.5

### Earthing the load

Even if the truck crane is already earthed (▶ p. 11 - 13), the load may become charged with static electricity. For example, if a hook block with synthetic sheaves or non-conducting sling gear is used.



#### Risk of accidents due to electric shock!

Always earth the load before operating the crane

- near strong transmitters (radio transmitters, radio stations, etc.),
- near high-frequency switchgear substations,
- if a thunderstorm is forecast.

If the load is charged with static electricity, you must always earth the load before touching it.

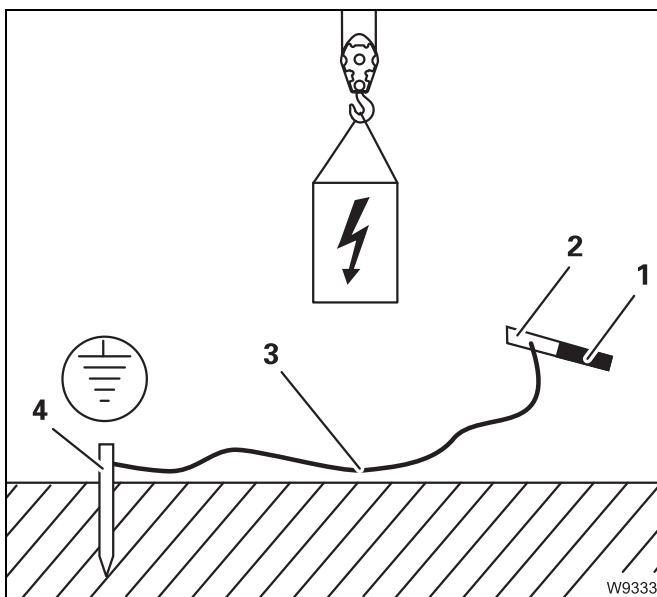

Use electrically conducting material for earthing.

- Hammer a metal rod (4) (length approx. 2.0 m) at least 1.5 m deep into the ground.
- For better conductivity, dampen the soil around the metal rod (4).
- Clamp an insulated cable (3) to the metal rod (4) (cross-section of at least 16 mm<sup>2</sup>).
- Clamp the other end of the cable (3) to a metal rod (2) with an insulated handle (1).

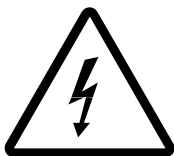

#### Risk of accidents due to electric shock!

Ensure that the connections between the cable and the metal rods are electrically conductive. When earthing, hold the metal rod only by the insulated handle and keep a sufficient distance to the metal rod in the ground.

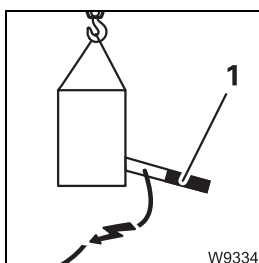

- Hold the metal rod firmly by its insulated handle (1).
- To earth, touch the load with the metal rod.

## 10.3

### MAXbase slewing range type

This slewing range type is available in addition to the *Standard* slewing range type; see *Standard slewing range type*, p. 10 - 21. You must decide between the two slewing range types when entering the rigging mode.

Lifting capacity tables with different, variable outrigger spans are available for the *MAXbase* slewing range type. These additional lifting capacity tables are supplied in digital form with the truck crane and can be shown as a diagram on the display in the crane cab.

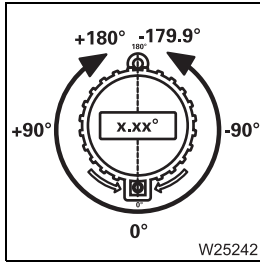

The designation of the slewing angle always relates to the starting point 0° to the rear. A full turn out of this working position is divided into two semi-circles.

- When slewing **clockwise** the slewing angle is displayed as a **positive** value (0° to +180.0°).
- When slewing **anticlockwise** the slewing angle is displayed as a **negative** value (0° to -179.9°).

## Enter the slewing range type

Possible types are the *Standard* slewing range type and, with the corresponding equipment, the *MAXbase* slewing range type. Different lifting capacity tables apply depending on the entered slewing range type and these then influence further input of the rigging mode.

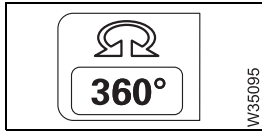

### - *Standard slewing range type*

The standard lifting capacity tables provided in printed form with the truck crane apply. All rigging modes listed there can be entered.

- The rigging mode can be specified via entry of the reeving and RCL code or via the individual components.
- In the case of individual components, the outriggers are always entered as complete outrigger span.
- In the case of individual components, the slewing range is entered according to the *lifting capacity table*.



An overview of all enabled Standard outrigger spans is provided in the section *Outriggers*;  *Supplied operating manual*.



### - *MAXbase slewing range type*

The MAXbase tables apply, which are only provided in digital form due to the wide diversity of configurations. All rigging modes listed there can be entered.

- The rigging mode is entered via the individual components.
- The outriggers are entered as individual widths for each outrigger beam.
- The enabled slewing range is displayed, divided into four areas with different lifting capacities.



An overview of all enabled MAXbase outrigger spans is provided in the section *Outriggers*;  *Supplied operating manual*.



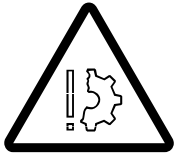

**Risk of accident due to incorrectly supported truck crane!**

A shutdown is not initiated as standard when an outrigger span monitoring error message is issued. When an error message is displayed, compare the rigged outrigger span with the required outrigger span and rig the required outrigger span.

This prevents the truck crane from tilting due to an inadequate outrigger span.

**MAXbase slewing range type**

If the *Standard* slewing range type has been entered; p. 10 - 41.

- Check that the current rigging mode of the truck crane corresponds to the displayed rigging mode.



**Risk of accidents due to an incorrectly set RCL!**

If the current rigging mode varies from the displayed rigging mode, the maximum load displayed by the *RCL* will not correspond to the actually permissible lifting capacity according to the *lifting capacity table*.

Overloading and accidents will certainly be the result.

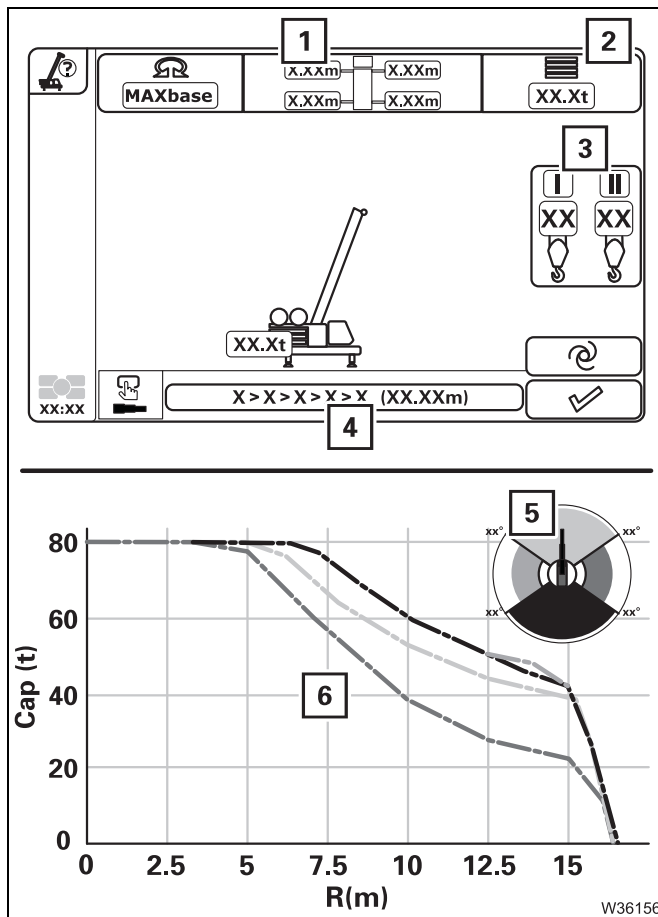

- Check:

- 1 The rigged outrigger span
- 2 The rigged counterweight
- 3 The number of reeved hoist rope lines

- Correct any incorrectly entered rigging modes if necessary.

The displayed lifting capacity tables apply to the preselected telescope status (4) in the respectively corresponding slewing ranges (5).

If the current rigging mode is displayed and the planned operations lie within the displayed operating ranges (6), then you can confirm the rigging mode.



**On the CCS display**

After confirming a permissible rigging mode, the *Start menu* opens automatically.

**Standard slewing range type**

If the *MAXbase* slewing range type has been entered; |||▶ p. 10 - 55.

The RCL display differs according to the confirmed slewing range.

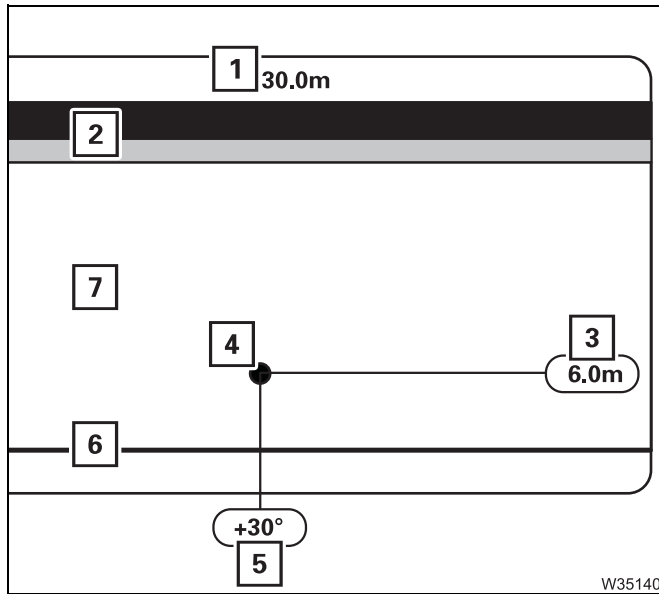

**360° slewing range**

The diagram (7) covers the entire width. The height of the diagram corresponds to the maximum permissible working radius (1), e.g. 30 m.

The current position of the boom head is shown using the symbol (4) and defined by two displays.

**3** Current working radius, e.g. 6 m

**5** Current slewing angle, e. g. +30°

The shutdown ranges for the maximum working radius (2) and – if active – for the minimum working radius (6) are shown in colour.

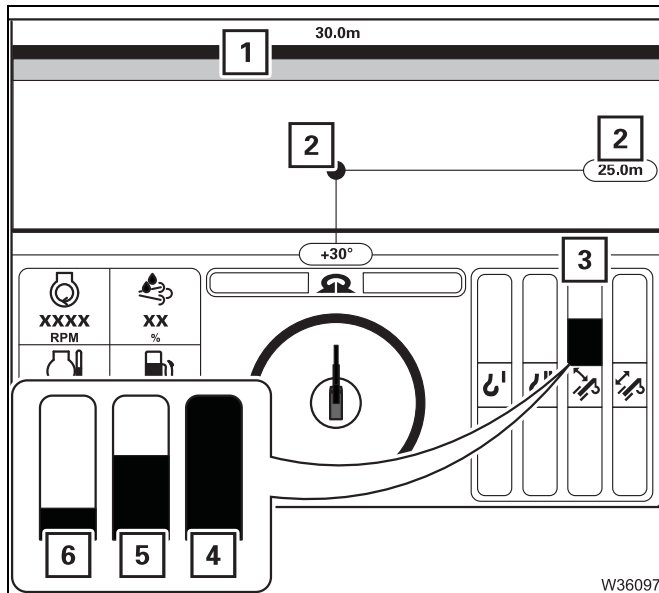

– When telescoping or derricking

The displays (2) move up and down to show the current working radius, e.g. 25 m.

In a shutdown range (1) the movement towards the shutdown limit is continually reduced until reaching a standstill.

The corresponding display (3) shows the current speed reduction, e.g. for lowering the boom.

**4 Green:** 26% to 100%

**5 Yellow:** 11% to 25%

**6 Red:** 0% to 10%



## 10.4.10 RCL override – version A

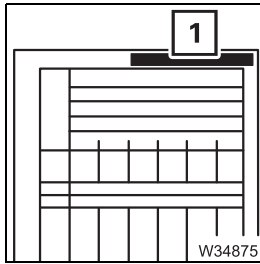

This section applies only when the supplied *lifting capacity table* contains the entry *EN 13000* in the header (1).

In the case of other entries; *RCL override – version B*, p. 10 - 67.

If the RCL is overridden, the crane operation is not monitored and the switched off crane movements are enabled again. Once the RCL is switched off, there are three options for overriding.

- **During rigging**, you can override the RCL shutdown or the lifting limit switch for rigging work; *When rigging*, p. 10 - 64.
- **You can leave the shutdown area** by enabling the raise boom function; *To raise the boom*, p. 10 - 65.
- **In an emergency** you can override the RCL shutdown completely; *In emergencies*, p. 10 - 66.

### Overview status display

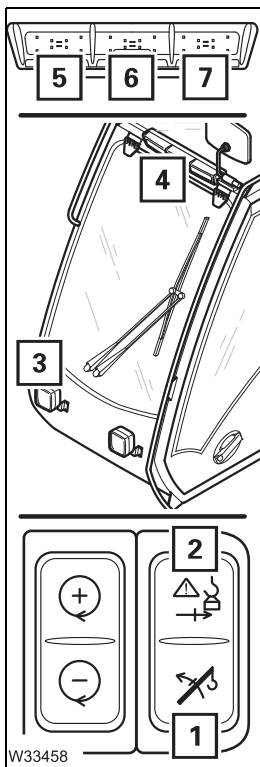

The lamps (5) to (7) of the status display (4) light up or flash depending on the RCL degree of utilisation and button confirmations.

Switch pressed	Degree of utilisation		
	0 - 90%	approx. 90 - 100%	Greater than 100%
No switch (normal operation)	Display (5) <b>green</b>	Display (6) <b>yellow</b>	Display (7) <b>red</b>
Button (2) Overriding for rigging	Display (5) <b>green</b>	Display (6) <b>yellow</b>	Display (6) <b>yellow, flashing</b>
Button (1) Raising	Display (5) <b>green</b>	Display (6) <b>yellow</b>	Display (5) <b>green, flashing</b>
Key-operated switch (3) RCL override in case of emergency	Display (7) <b>red, flashing</b>	Display (7) <b>red, flashing</b>	Display (7) <b>red, flashing</b>



## 10.5

## Crane operation with main boom

### 10.5.1

### Checks during crane operation

#### Horizontal alignment

During crane operation, the truck crane may tilt if the ground gives way due to varying loads.



#### Risk of accidents if the truck crane is not level!

The RCL calculates the working radius from the length and angle of the main boom. The actual working radius changes and there is a danger of the crane overturning if the truck crane is not level!

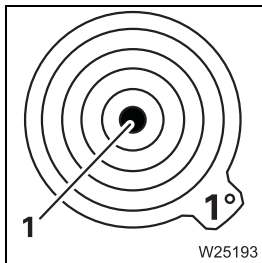

- Check the horizontal alignment of the truck crane during crane operation on the display (1); p. 11 - 58.

Due to deformation of the frame, the horizontal alignment can change by up to 2° when the superstructure is turned from the 0° or 180° position. If the truck crane does not return to the horizontal position after being turned back to the 0° or 180° position, you must immediately determine the cause and eliminate it and, if necessary, realign the crane. Observe the position of the superstructure when doing so; *Levelling the truck crane on outriggers*, p. 11 - 58.

#### Safe distances

During crane operation, always ensure that the truck crane and the load are at a sufficiently large distance to objects and persons. Pay particular attention to objects that pose a direct danger (e.g. gas containers or scaffolding).

Keep a safe distance away from electrical lines; *Safe distance from overhead power lines*, p. 11 - 14.



### Lifting limit switch override

When overriding, the shutdown of the lifting limit switch is cancelled and the crane operation is no longer completely monitored.



#### Risk of accidents if the lifting limit switch is overridden!

You may override the lifting limit switch only if this is specified in the operating instructions for carrying out maintenance or rigging work. With the lifting limit switch overridden, you may drive only at the minimum speed and without a load.



#### Risk of accidents due to gaps in monitoring!

If the lifting limit switch is overridden, crane operation is no longer completely monitored. When hoisting the lifting limit switch weight, the crane movement will be stopped once. After moving the control lever again, the crane movement will again be enabled and will not be switched off again.

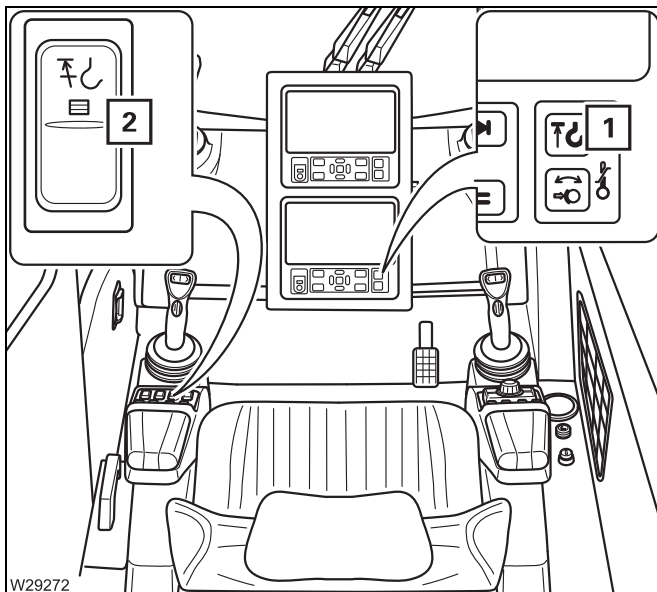

- Press the button (2)
  - Lamp (1) flashes.
  - A buzzer tone sounds.

If the lifting limit switch is triggered now, the crane movement is stopped **once**.

The stopped crane movement is enabled again if you bring the control lever to zero position and then move it again.

This crane movement will now not be stopped again.

#### Cancelling the override

- Release the button (2) or leave the shutdown range.
  - The lamp (1) goes out.
  - The buzzer tone is switched off.



**Assignment for display**

The CCS display shows a sectional view of the main boom in the menus.

The following elements are displayed:

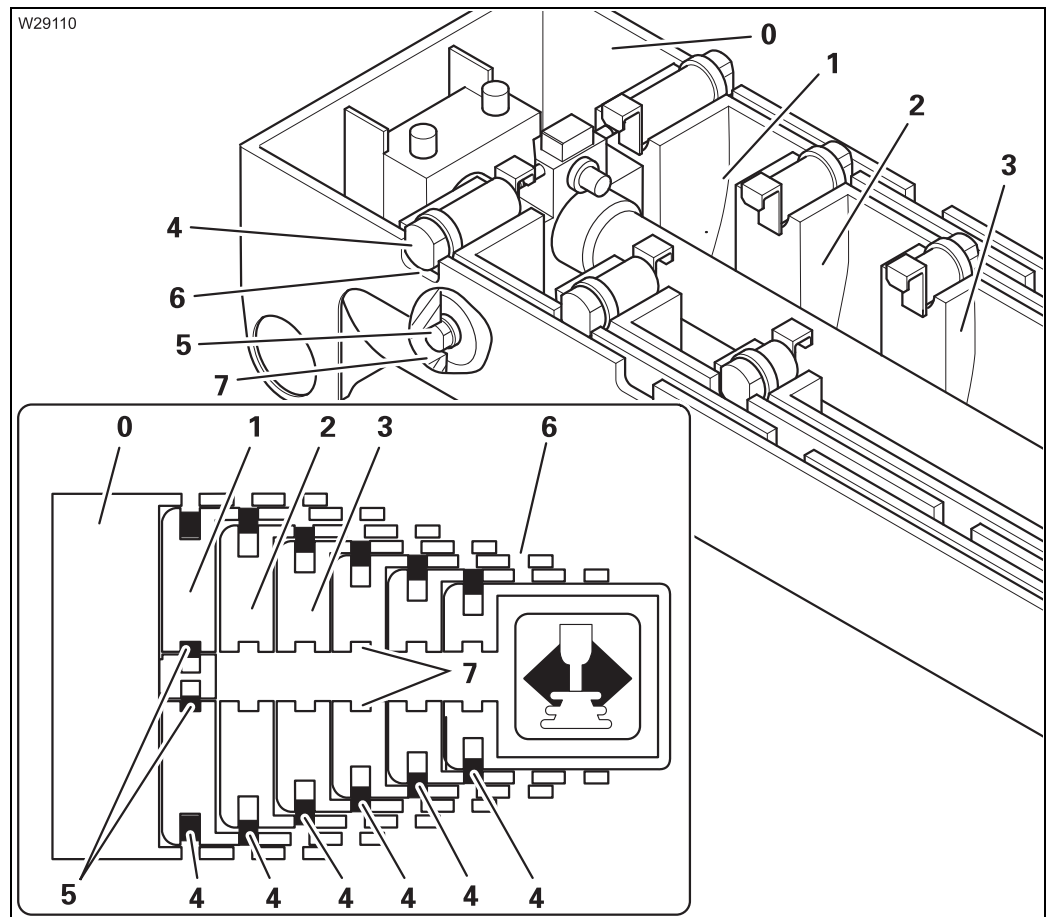

- 0 Basic section
- 1 Telescopic section I
- 2 Telescopic section II
- 3 Telescopic section III
- 4 Locking pin on the telescopic section
- 5 Locking pins on the telescoping cylinder
- 6 Cutouts, external
- 7 Cutouts, internal



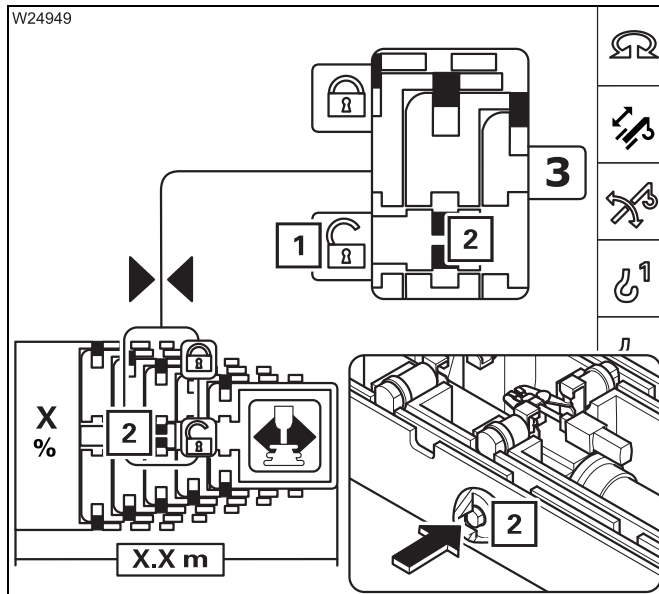

### Unlocking

- Select the symbol (1).

Confirm the selection – the locking pins (2) will retract.

- **Yellow:** Intermediate position
- **Red:** Unlocked



## 10.5.7

### High-speed mode



The slewing gear cannot be operated in high-speed mode.



You can switch on the high-speed mode for a higher speed.

#### **Risk of accidents due to the suddenly accelerating movement!**

Reduce the engine speed before starting high-speed mode.

This will prevent movements from becoming excessively accelerated, which may result in the truck crane starting to sway and overturning.

#### **Derricking gear telescoping mechanism**

High-speed mode is always switched on and off for the derricking gear and the telescoping mechanism at the same time.

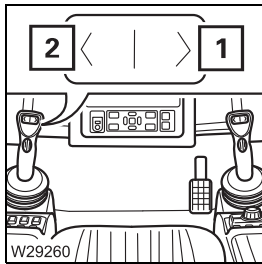

#### **To switch on briefly**

- Press the button at the left on – for (1).  
High-speed mode will be active until you release the button.

#### **Continuous operation**

- Press the button at the right on – for (2).  
High-speed mode will be enabled until you press the button again.

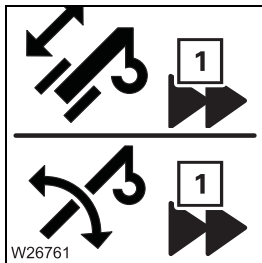

The symbol (1) indicates the current status:

- **On:** High-speed mode switched on
- **Off:** High-speed mode switched off



During lowering of the boom, high-speed mode only supports the start-up of the derricking procedure from steep boom positions; it does not increase the derricking speed.

High-speed mode is disabled for raising when performing operations with the lattice extension.



## 10.6.4 Limiting the power unit speeds

You can enter what percentage of the maximum speed should be enabled for each power unit.

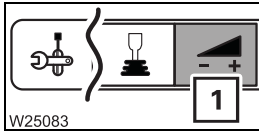

- Open the *Power unit speeds* menu (1).

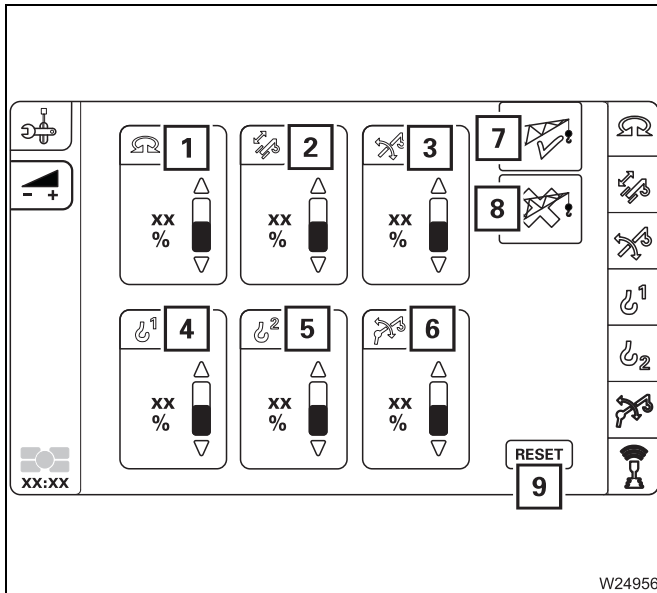

The values below the symbols (1) to (6) indicate the currently set power unit speeds.

The values for the slewing gear (1) and derricking gear (3) only apply if they are lower than the automatically limited values. The automatically limited values are not displayed.

The symbol (5) is only active when the auxiliary hoist is connected.

With the preselection symbol for:

- 7 Operation **with** the lattice extension
- 8 Operation **without** the lattice extension

Symbol (9) resets all values without prior selection.

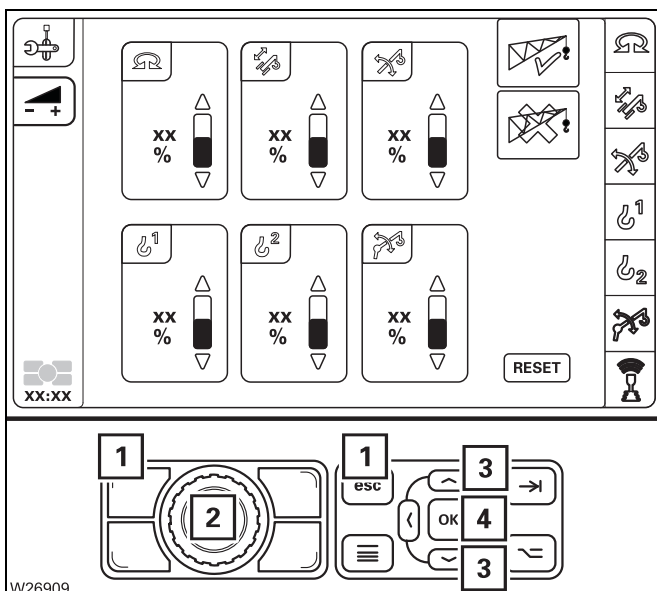

### Changing values

- Select and confirm the symbol for the relevant power unit – symbol **red**.
- Change the value using switch (2) or the buttons (3).

To cancel the input – press button (1) once.

- Confirm the changed values – press switch (2) or button (4) once. The changed values for the power unit are applied.

**In the CCS  
Start menu**

The *RCL* shows the limited working range for the *slewing angle* and *working radius* monitoring systems.

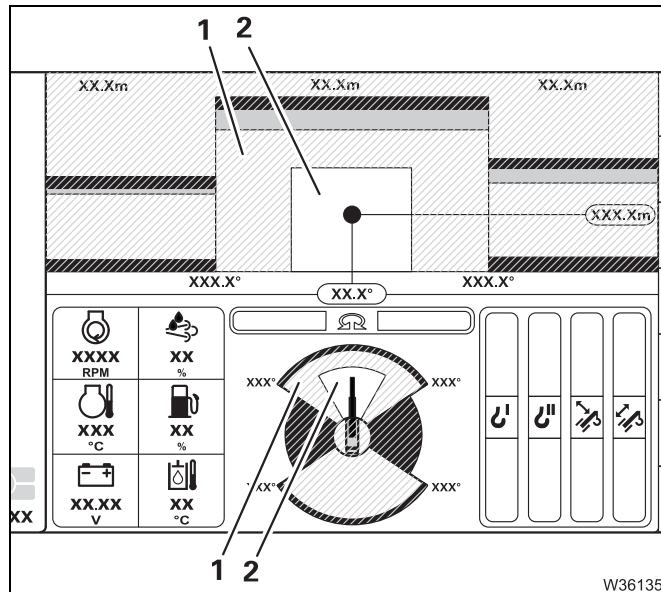

Display examples for switched-on *slewing angle* and *working radius* monitoring systems.

- 1 Permissible working range according to the *lifting capacity table* – shown darkened
- 2 Limited working range – shown lightened

**10.7.2 Opening the working range limiter menu**

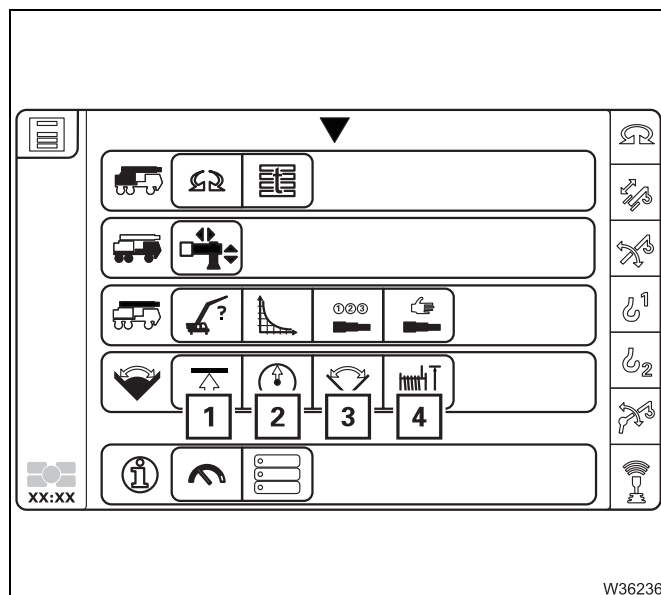

- Open the *Menu groups overview* menu if necessary and select the corresponding symbol (1) to (4).

The corresponding *Working range limiter* menu opens.







## 10.7.6

### Shutdown by working range limiter

If a limit value is reached, RCL shutdown will occur. All movements that would go closer to the limit value will be disabled. Shutdown will remain active even if you switch off the monitoring function.

The RCL display also shows an information symbol. You must leave the shutdown area in order to enable the movement.

RCL display	Shutdown point reached for	Disabled movements
	Overall height	<ul style="list-style-type: none"> <li>- Raising</li> <li>- Extending</li> <li>- Lowering the hoist</li> <li>- Derricking the lattice extension</li> </ul>
	Working radius	<ul style="list-style-type: none"> <li>- Lower</li> <li>- Extending</li> <li>- Lifting the hoist</li> <li>- Derricking the lattice extension</li> </ul>
	Slewing angle <b>A</b>	- Slew to the left
	Slewing angle <b>B</b>	- Slew to the right
	Rope travel limitation Lifting	- Lifting
	Rope travel limitation Lowering	- Lowering



#### Risk of accidents due to overriding shutdown procedures!

Override RCL only if it is absolutely necessary and you have a clear view of the hazard area. Bear in mind that, due to the boom bending for example, the overall height is increased if you set down the load.

If you override the RCL, the shutdown will be overridden and all movements enabled.

## Switching heating start on/off

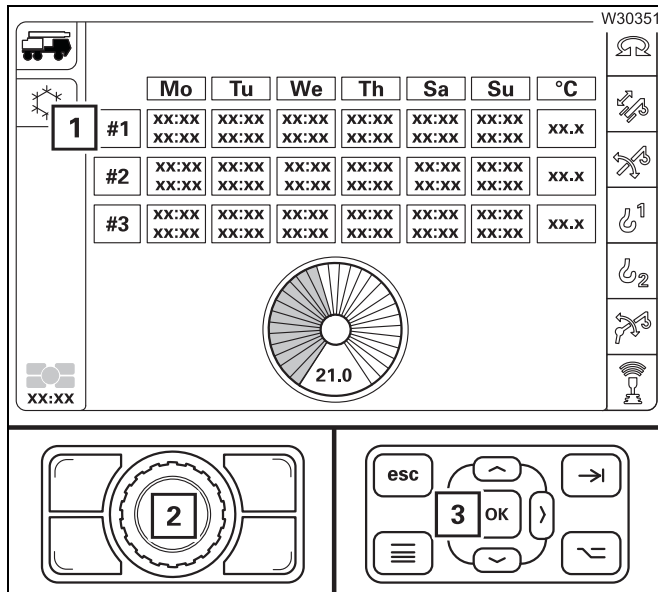

### Switching on

- Select a storage location (e.g. #1) – symbol **(1) red**. You can also selected other storage locations.

The auxiliary heating now starts at the times stored in the corresponding column.





### Switching off

- Select a storage location (e.g. #1) – symbol **(1) grey**. You can also selected other storage locations.
- Change and confirm the respective values using the controls **(3)** or **(4)**.

## 11.2

### Selecting the suitable site

Choose the position of your truck crane at the site with care. Observe the following aspects:

- Check that the ground has sufficient load bearing capacity. You may need to enlarge the ground bearing area;  p. 11 - 9.
- Observe the required safe distances from slopes and pits;  p. 11 - 12.
- Earth the truck crane if there is a danger of it being charged with static electricity;  p. 11 - 13.
- Keep a safe distance away from electrical lines;  p. 11 - 13.
- Choose the site such that the unevenness of the ground can be compensated for by adjusting the outrigger cylinders. Maximum hoist of the outrigger cylinders;  p. 1 - 17.
- Choose a location where it is possible to keep the working radius to a minimum and where no obstacles are within the slewing range of the crane.

### 11.2.1

#### Determining the required load-bearing area

The stability of the truck crane depends in the first instance on the load bearing capacity of the ground. The load bearing capacity of the ground and the occurring outrigger pressure determine the load-bearing area required for the operation.

$$\text{Load-bearing area (m}^2\text{)} = \frac{\text{Outrigger pressure (t)}}{\text{Load bearing capacity of the ground (} \frac{\text{t}}{\text{m}^2}\text{)}}$$

#### Outrigger pressure

- Determine the outrigger pressure for the operation planned using the *Outrigger pressure table*.



### 11.3.3

## Switching off boom pre-tensioning

You must switch off the boom pre-tensioning before you raise the main boom off the dolly.

To switch off boom pre-tensioning, you must bring the valves I to IV into the required positions, which will empty the pressure accumulator.



### **Danger of the hydraulic oil overheating!**

Always switch the valve IV over (lever in horizontal position) before operating the crane.

This prevents the pressure in the hydraulic circuit rising and the hydraulic oil exceeding the permissible temperature of 80 °C .

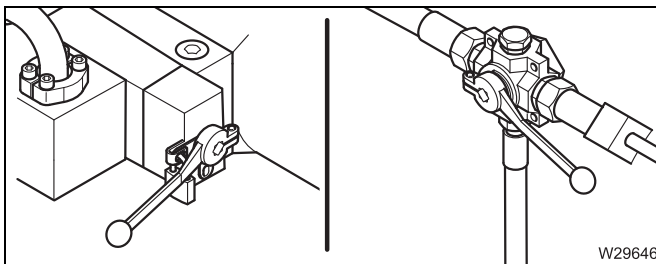

- Switch off the boom floating position;  
    ▣▣▣▣ p. 11 - 17.

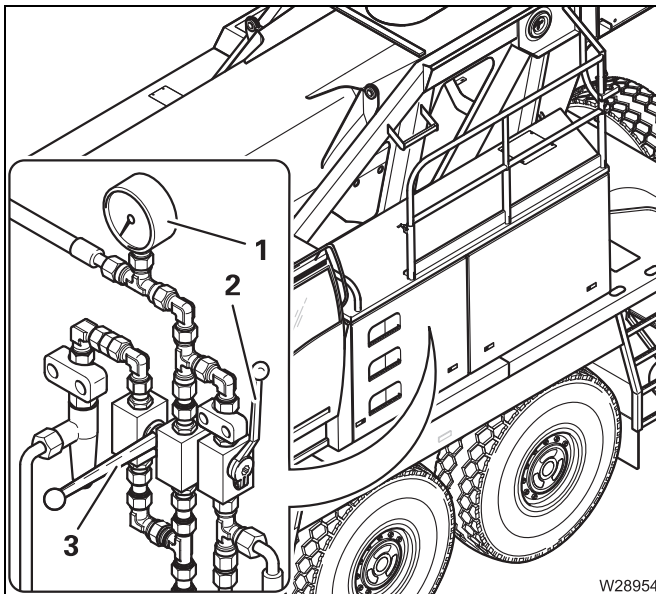

The valves II and III are located underneath the pressure gauge (1).

- Open valve II – the lever (2) is vertical.

The pressure accumulator is emptied. The pressure on the pressure gauge (1) must drop to 0 bar .

Valve III stays closed – the lever (3) points downwards.

## 11.7

### Outriggers – Overview – MAXbase slewing range type

The information in this section applies to the *MAXbase* slewing range type. If you wish to operate the truck crane using the *Standard* slewing range type;  p. 11 - 27.

Symmetrical and various variable outrigger spans are enabled. There are several different types of outrigger spans, each with several permissible combinations.

Separate *lifting capacity tables* for the variable outrigger spans are provided in digital form. Observe all the specifications and definitions in these tables before commencing operation.

#### 11.7.1

#### Definitions

Specific terms and graphical illustrations are used in the description.

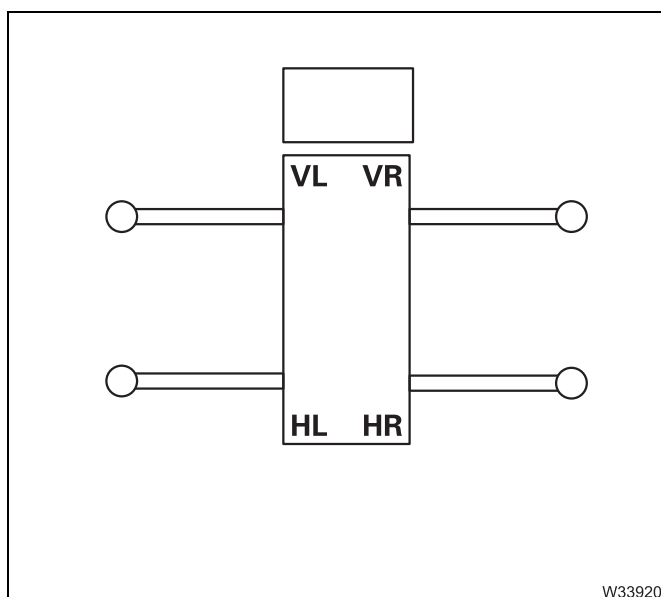

#### Designation of the outrigger beams

<b>VL</b>	Front left
<b>VR</b>	Front right
<b>HL</b>	Rear left
<b>HR</b>	Rear right



## 11.8.2

### CHECKLIST: Retracting the outriggers



This checklist is not a complete operating manual. There are accompanying instructions, which are indicated by cross-references.

**Observe the warnings and safety instructions there!**

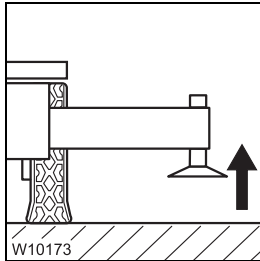

1. Retract the outrigger cylinders as far as possible; p. 11 - 53.

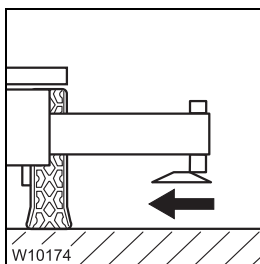

2. Move the outrigger pads into the driving position and secure them;  
 *Moving into driving position*, p. 11 - 51.

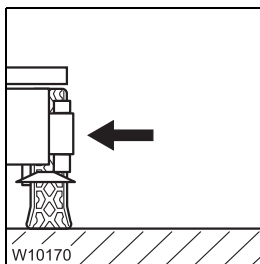

3. Fully retract and secure all outrigger beams;  
 *For on-road driving*, p. 11 - 44,  
 *Extending/retracting outrigger beams*, p. 11 - 45.

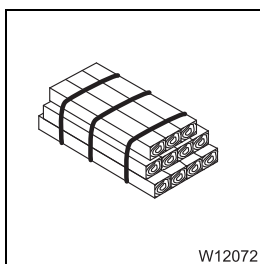

4. Stow away packing material safely, if applicable.

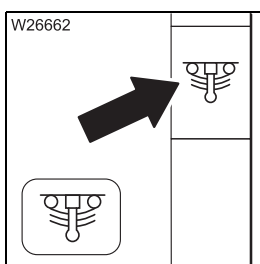

5. Activate the suspension (release locking).  
The symbol must be **green** (suspension on); p. 5 - 16.



**From the crane cab**

The operating elements are in the *Outriggers* submenu.

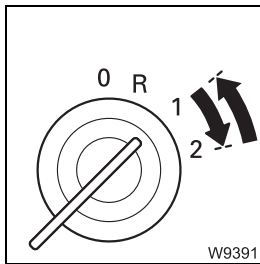

**Start the engine**

- Start the engine from the crane cab; p. 9 - 5.
- Switch off the slewing gear; p. 10 - 115.

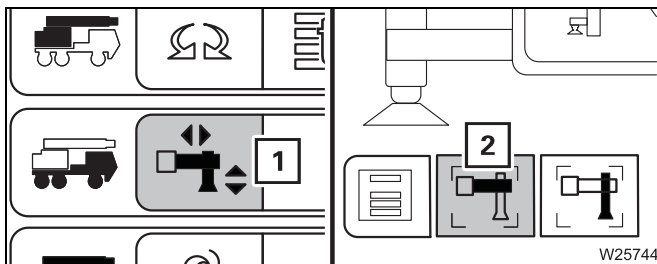

**Open menu**

- Open the *Outrigger* menu (1).
- Select and confirm the symbol (2) – *Move outrigger beams*.

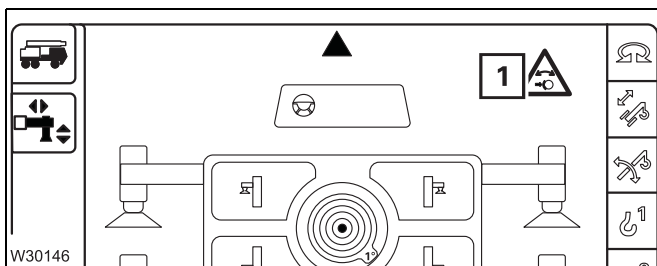

When the turntable is switched on the symbol (1) is displayed and outrigger motion is disabled.

- Switch off the slewing gear – symbol (1) goes out.

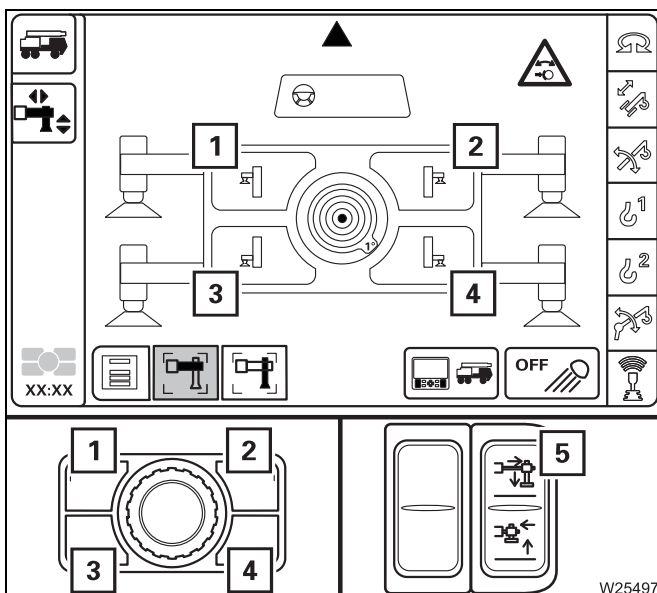

**Extend**

- Press the button for the desired outrigger beam.
  - 1 Front left
  - 2 Front right
  - 3 Rear left
  - 4 Rear right
- Press the button (5) in at the top – the selected outrigger beam extends.



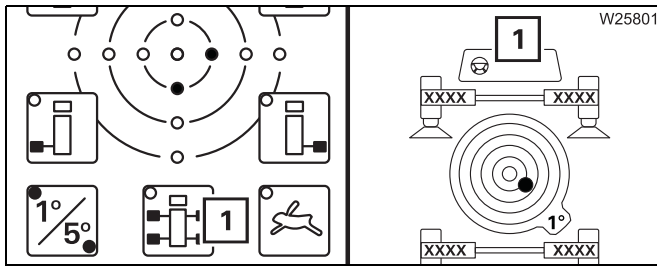

– Manual control/ CCS display

The assignment to the carrier is given by the directional indicator (1).

In this example, the carrier would be standing higher to the rear on the right hand side.

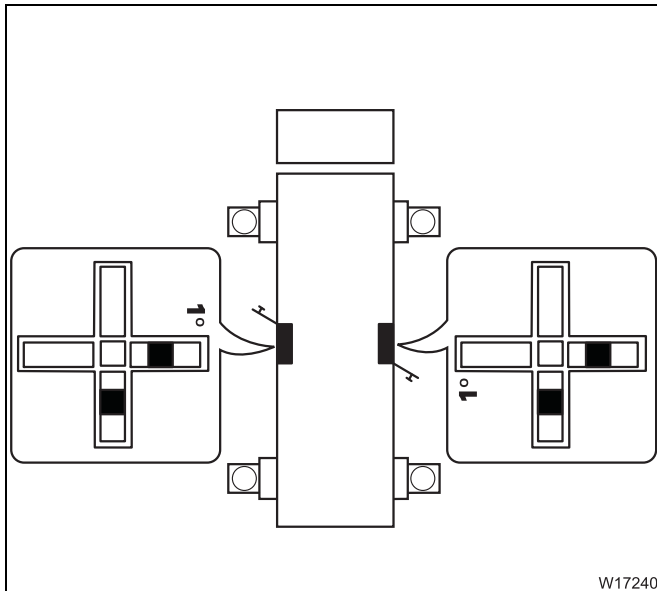

– Outriggers control units

The assignment to the carrier corresponds to the top view.

Due to the position of the control units, the displays on both sides differ.

In this example, the carrier would be standing higher to the rear on the right hand side.

**Prerequisites**

The following prerequisites apply to manual and automatic alignment.

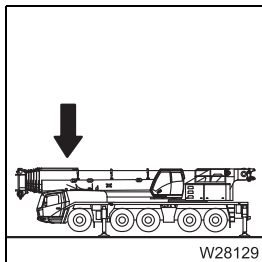

The main boom must be resting on the boom rest.

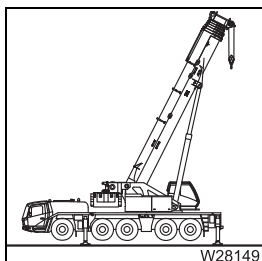

or

- The main boom must be raised **and**
- The load must have been set down **and**
- The superstructure must be in the 0° or 180° position.



## 11.9.2 Counterweight sections

The counterweight combinations can be comprised of:

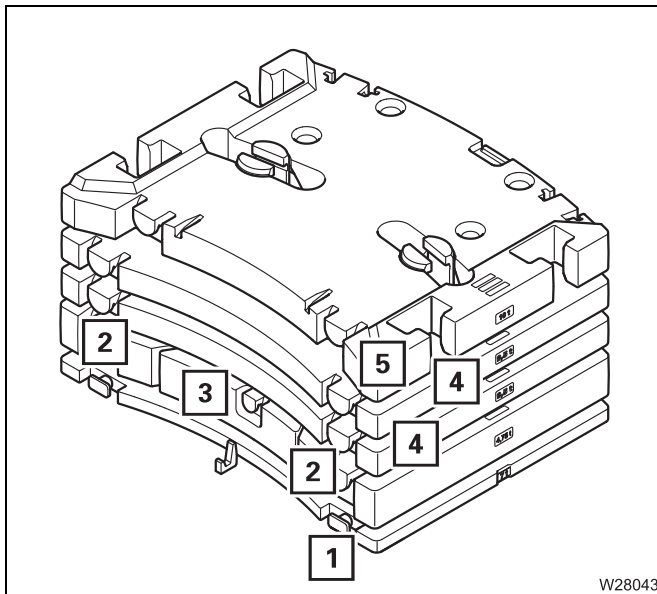

### Counterweight 50 t

- One 7 t base plate (1)
- Two 4.75 t counterweight sections (2)
- One 4.5 t counterweight section (3)
- Two 9.5 t counterweight sections (4)
- One 10 t counterweight section with recesses (5)

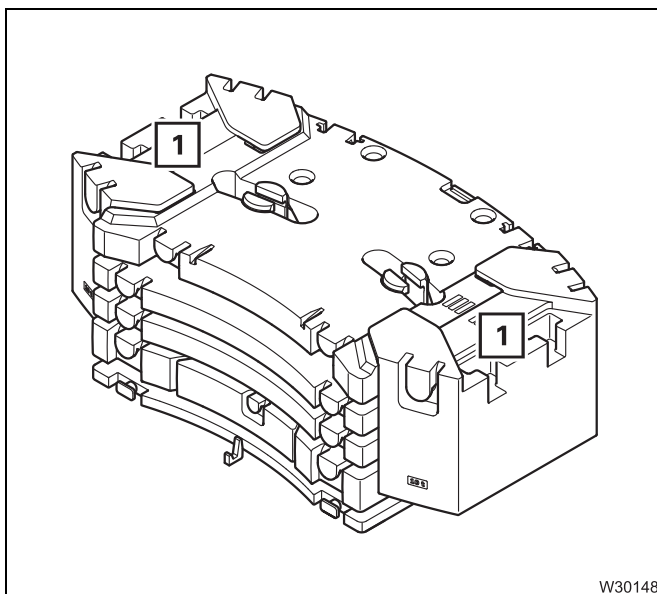

### Counterweight 70 t

- Two 10 t blocks (1)

Counterweight sections	Counterweight combination in t					
	0.0	7.0	16.5	21.0	26.0	30.5
5.0 t blocks	-	-	-	-	-	-
10.0 t blocks	-	-	-	-	-	-
10.0 t section	-	-	-	-	-	-
9.5 t section	-	-	-	-	5	5
4.5 t section	-	-	-	3	-	3
4.75 t section	-	-	2 + 4	2 + 4	2 + 4	2 + 4
7.0 t base plate	-	1	1	1	1	1

Counterweight sections	Counterweight combination in t				
	35.5	40.0	45.5	50.0	70.0
5.0 t blocks	-	-	-	-	-
10.0 t blocks	-	-	-	-	2 x 6
10.0 t section <sup>1)</sup>	-	-	7	7	7
9.5 t section	2 x 5	2 x 5	2 x 5	2 x 5	2 x 5
4.5 t section		3	-	3	3
4.75 t section	2 + 4	2 + 4	2 + 4	2 + 4	2 + 4
7.0 t base plate	1	1	1	1	1

1) 7 must always be on top



### Automatic mode unrigging

While the automatic mode is being executed, you can always

- **Cancel** the automatic mode;  *Cancel automatic mode*, p. 11 - 90.
- **Cancel** the automatic mode by letting go of the control lever. After moving the lever in the displayed direction once more, the automatic mode is continued.

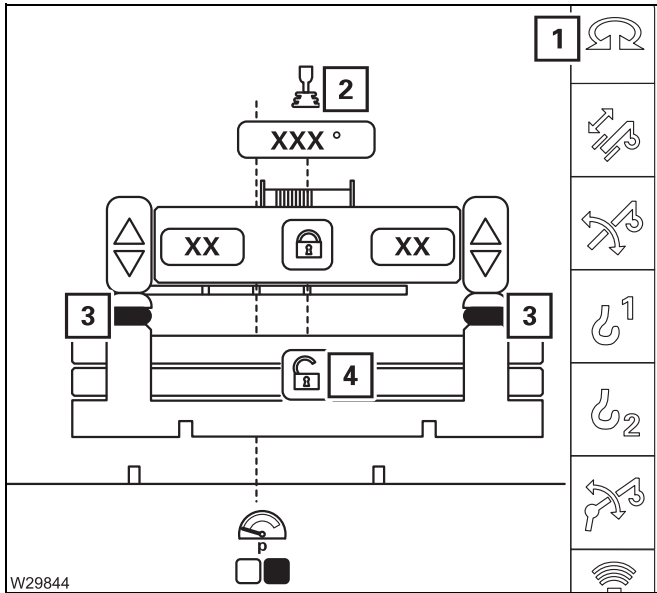

### Prerequisites

- The lifting cylinders must be fully retracted – symbol (3) **green**.
- The slewing gear is switched – symbol (1) **green**.
- The superstructure must be in the rigging range:
  - Symbol (4) active,
  - Symbol (2) displayed.

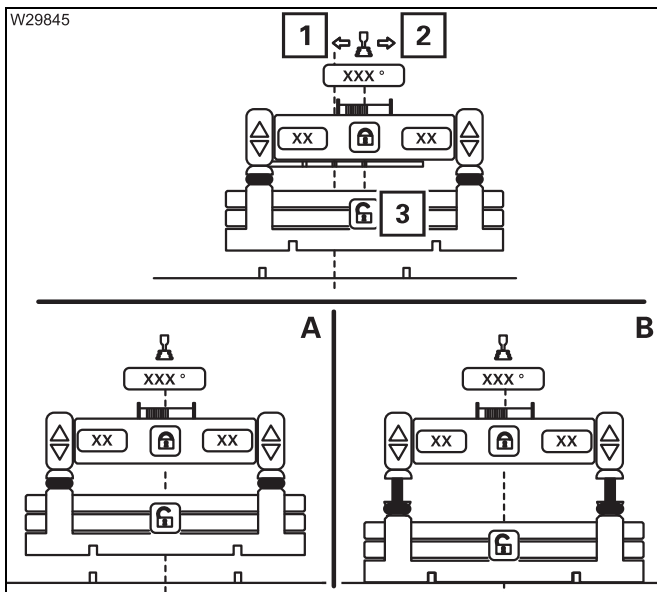

### Switch on automatic mode

- Select and confirm the symbol (3).

### Execute automatic mode

- Move the slewing control lever in the displayed direction (1) or (2) – the automatic mode starts.
  - The superstructure turns into position (A).
  - The lifting cylinders extend (B).
- Release the control lever.



### 11.10.3 Hook block on a separate vehicle



#### **Risk of overturning while slewing!**

Always check before slewing whether slewing is permitted in the truck crane's current rigging mode. Correct the rigging mode if necessary;  
▣▣▣▣▶ *Slewing with the rigged counterweight*, p. 11 - 93.



#### **Danger of overturning when slewing with an overridden RCL!**

Do not override the RCL before slewing the superstructure.  
If slewing is not enabled then, for the *Standard* slewing range type enter a rigging mode for the 360° working range or for the *MAXbase* slewing range type enter a working radius for which slewing is enabled.  
This prevents slewing into impermissible areas and the truck crane tipping over as a result.



#### **Risk of damage to the separate vehicle!**

Raise the hook block from the separate vehicle only when the main boom head is directly above the hook block!  
This prevents the hook block swinging and damaging the separate vehicle.



#### **Risk of damage to the hoist rope!**

To prevent slack rope, do not ease down too much hoist rope when picking up and reeving the hook block!  
Slack rope causes rope loops on the hoist drum, which can result in the load slipping and the hoist rope being damaged!



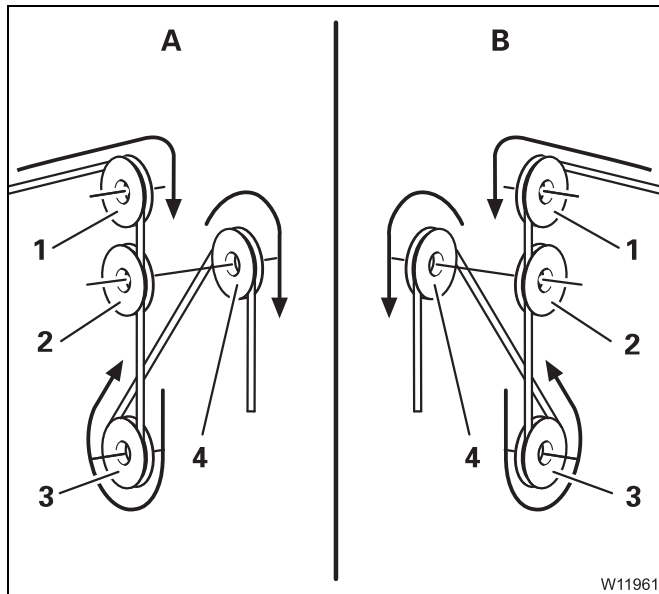

### Reeving the hoist rope

- A** For the main hoist rope
- B** For the auxiliary hoist rope

- Guide the hoist rope over the upper head sheave (1) to the lower head sheave (2).
- Guide the hoist rope from the front around the outer pulley (3) of the hook block, upwards to the main boom head.
- Guide the hoist rope from the rear over the next required head sheave (4), etc.
- Reeve the hoist rope with the required number of lines.

Possible reeving methods; p. 11 - 112.

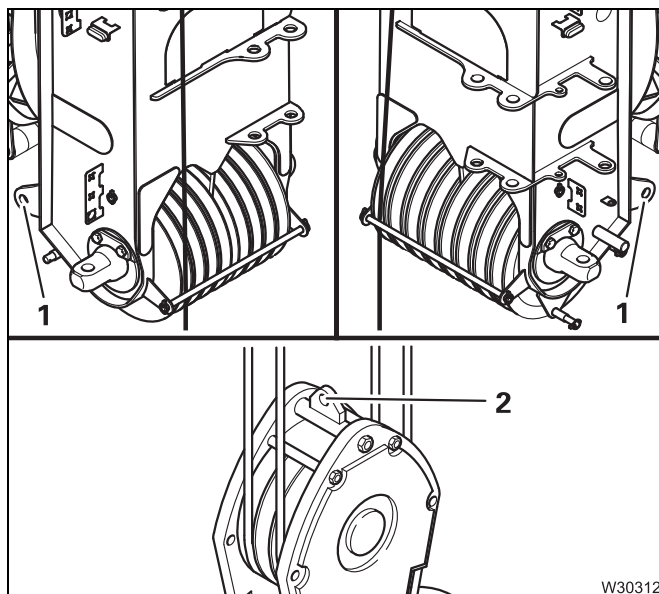

### Fastening the hoist rope

The fixed point used depends on the number of reeved rope lines.

- **Fixed point for an even number of lines**  
The rope end fitting is fastened to a fixed point (1) or (2) for 2-fall, 4-fall, 6-fall reevings, etc.
- **Fixed point for an odd number of lines**  
The rope end fitting is fastened to the fixed point (3) for 1-fall, 3-fall, 5-fall reevings, etc.



## Removing the lifting limit switch

This section describes complete removal.

If the hook block is to be subsequently attached to the bumper, you only need to detach the lifting limit switch weight from the hoist rope in order to be able to unreeve or re-reeve the hoist rope when unrigging. You can place the lifting limit switch weight around the hoist rope again before driving.

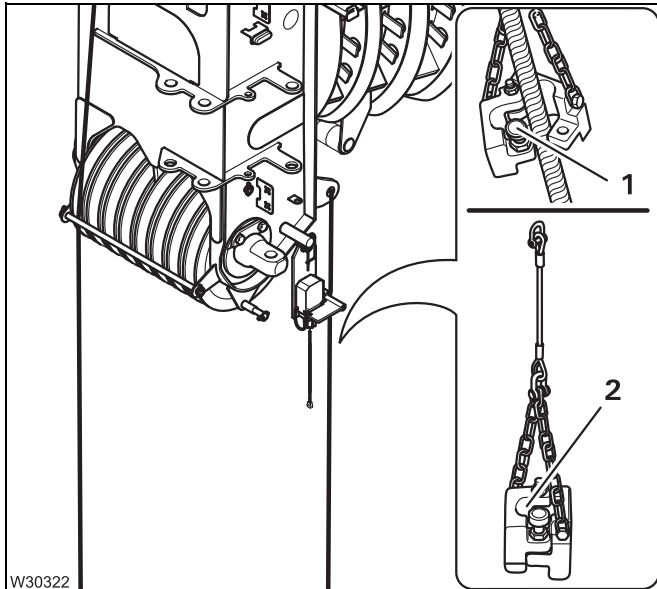

### Removing the lifting limit switch weight

- Pull the safety pin (1) out and fold the two halves of the weight apart.
- Remove the halves of the weight from the rope line.
- Pull the safety pin (1) out, fold the two halves of the weight back together and let the safety pin engage.
- Remove the lifting limit switch weight (2).
- Remove the lifting limit switch weight on the other side too, if necessary.

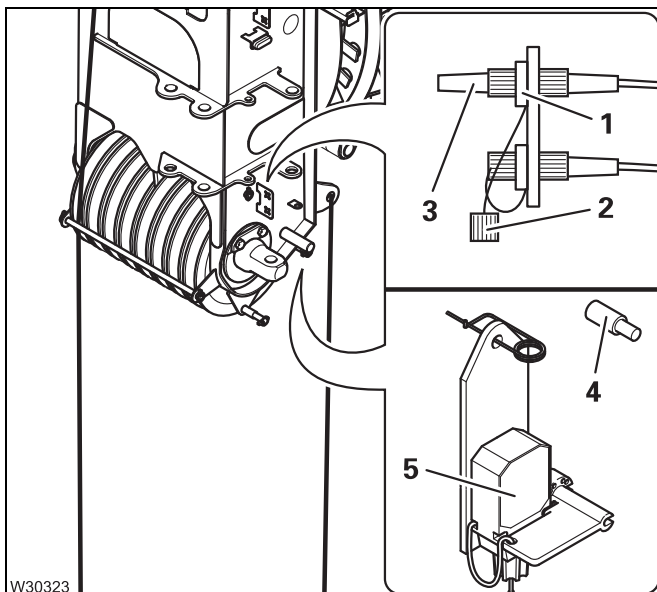

### Removing the left lifting limit switch

- Pull the plug from the socket and close the socket (1) with the protective cap.
- Remove the lifting limit switch (3) from the bracket (2).
- Fasten the retaining pin on the lifting limit switch.



## Attaching/detaching fall prevention safety system to/from safety harness

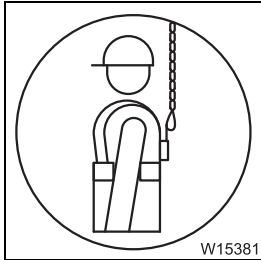

### Attachment

All points designed for fastening a fall prevention safety system are marked with a symbol.

- When stepping, observe the following procedure so that you are always secured.



### Risk of accidents due to incomplete safety system!

Make sure you always attach one line of the fall prevention safety system with the safety harness before stepping onto the main boom. This will prevent falling due to an incomplete safety system.

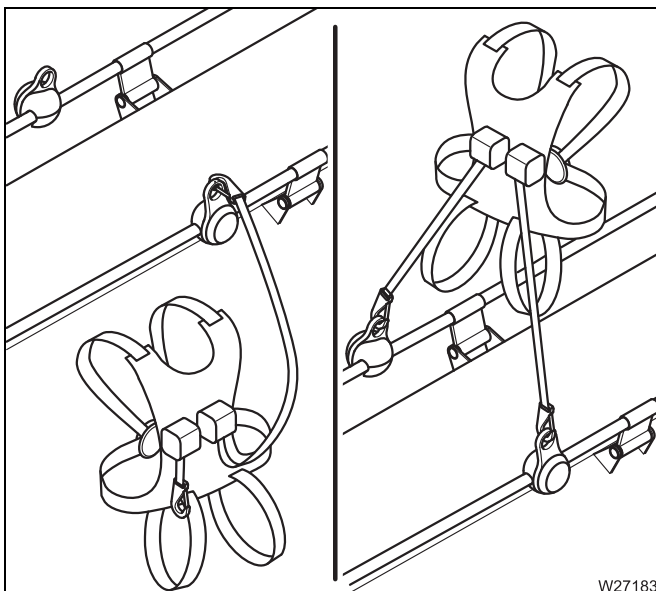

- Always ascend the truck crane using only the ladders and access ladders provided.
- Make sure you always attach one line of the fall prevention safety system with the safety harness before entering the main boom.
- Attach the second line of the fall prevention safety system with the safety harness once you are located on the main boom.



# 12

## Driving with a rigged truck crane

This section describes driving the truck crane with the counterweight rigged. If a lattice extension is also rigged;  *Operating Instructions Lattice Extension*.



### **Risk of accidents due to partially obstructed view of the truck crane!**

When driving the truck crane, always stay in visual or radio contact with a banksman who can observe the parts you are unable to see, e.g. the raised main boom in the  $0^\circ$  to the rear position.



### **Risk of overturning by slewing the superstructure!**

When driving the rigged truck crane, the slewing gear must be switched off – slewing gear brake engaged.



### **Risk of accidents when driving with a lifted load!**

Driving the truck crane with a load lifted is prohibited. Always set down the load prior to driving the truck crane and secure the hook block so it cannot swing.

## 12.1

### Driving path

The path to be driven must be level. Uneven surfaces cannot be compensated with the level adjustment system.

The entire driving distance must be level. The rigging modes and axle loads specified in this chapter only for driving distances which are free of inclines in longitudinal and lateral direction.

The ground must be stable enough to bear the axle loads.

If the surface pressure of the tyres exceeds the permissible load on the ground, the surface area of the tyres must be increased by packing stable material (e.g. wooden planks).

## 12.4

### While driving

- Drive only at the lowest possible speed, **maximum 1.5 km/h**
- The turning radius should be as great as possible when driving around corners!
- Steer the truck crane when it is moving, and avoid sudden changes to the steering!



#### Risk of damage to the steering linkage

The steering linkage can be damaged if the steering wheel is moved while the vehicle is stationary.



#### Risk of damage to the axle lines!

The suspension struts could be damaged if the maximum permissible operation pressure in the suspension is exceeded. Always monitor the operation pressure in the suspension when moving the rigged truck crane.

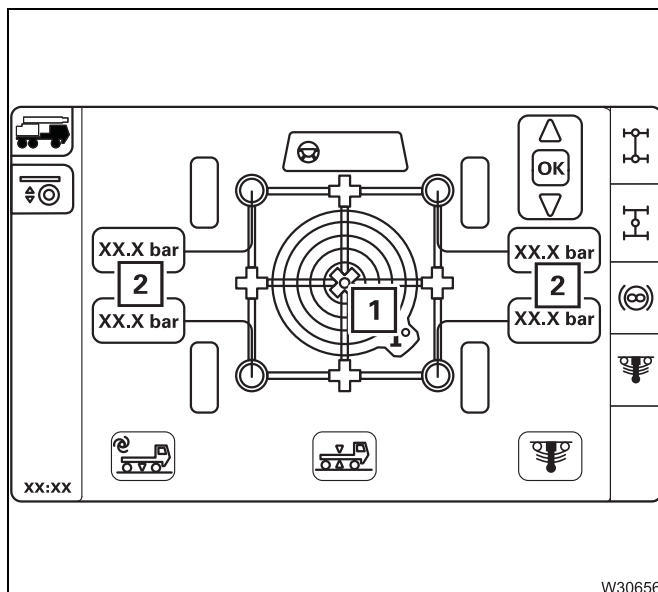

#### Warnings while driving

If a buzzer tone sounds in the driver's cab, stop the truck crane immediately and check whether:

- The permissible lateral tilt (1) of max. 1°  
or
- The suspension operation pressure (2) of 210bar has been exceeded.

In this case, you must level the truck crane again; *Aligning the truck crane*, p. 12 - 7.



#### Danger of overturning by switching on the suspension

Never attempt to level the crane horizontally using the level adjustment system. The suspension must be deactivated (locked) while the rigged truck crane is on wheels.

Switching on the suspension would cause the suspension cylinders to be suddenly pressed together and damaged, and the truck crane could overturn.

## 14.3 Warning and error messages

### Program version

- Always note down the number of the program version and the serial number after a malfunction occurs before notifying **Manitowoc Crane Care**.

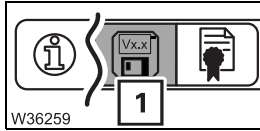

- Open the *Program version* menu (1).

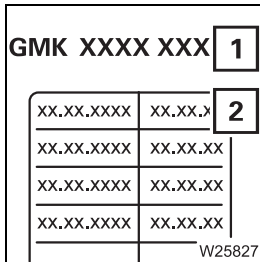

- Serial number display
- Program version display

### 14.3.1 Warning messages on the CCS display

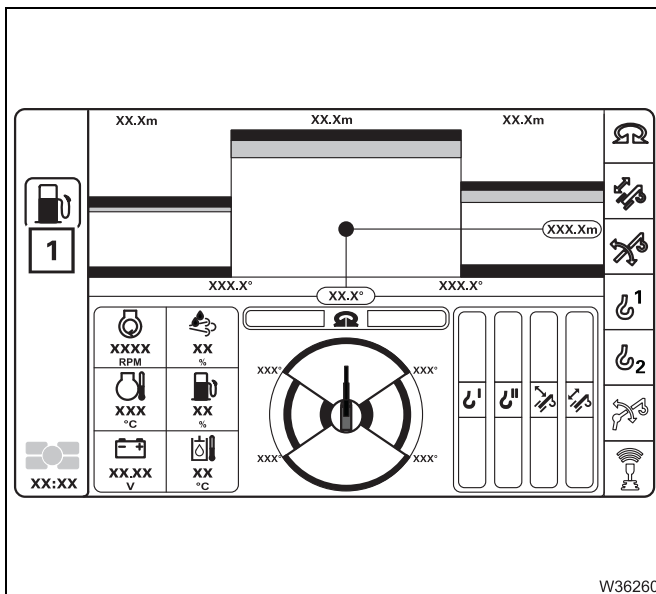

If the CCS detects a malfunction then a symbol is shown in the display area, e.g. the symbol (1).

If several warning messages exist, all of the corresponding symbols are displayed one after the other in consecutive order.



## 14.4 Finding and eliminating malfunctions

### 14.4.1 Malfunctions on the engine



Observe all specifications in the section *Malfunctions on the engine*; p. 7 - 17.

Malfunction		Cause	Remedy
<b>Engine does not start – Starter does not turn</b>		Driving mode switched on	Switch over to crane operation;  p. 9 - 1
<b>Symbol is red</b>		Engine malfunction	

### 14.4.2 Malfunctions on the main hoist/auxiliary hoist

Malfunction		Cause	Remedy
<b>Main hoist not working or malfunctioning</b>		Hoist off, lamp in button lights up dimly	<i>Switching on the main hoist</i> , p. 10 - 76, <i>Switching on the auxiliary hoist</i> , p. 10 - 79
		Dead man's switch not actuated	Press dead man's switch
		Emergency stop switch engaged	<i>Resetting the emergency stop switch</i> , p. 4 - 22
		Fuse is blown	Replace blown fuse; p. 14 - 63
		Fuse blown on circuit board	Replace blown fuse; p. 14 - 63
		Control unit faulty, error message is displayed	Acknowledge error message once;  p. 14 - 3 – if error persists, notify <b>Manitowoc Crane Care</b>
<b>Only the lifting function works</b>		Lowering limit switch approached	Leave the shutdown range and lift the main hoist



### 14.4.14 Malfunctions on the CCS/RCL control units

Malfunction	Cause	Remedy
<b>Control unit not working</b>	Power supply not switched on	Switch on the ignition
	Fuse F1/4 blown	Replace blown fuses; ▮▮▮▮▶ p. 14 - 63
<b>Display is dark – LED flashes blue</b>	Ambient temperature too low	Heat the crane cab
<b>Display is dark – LED flashes yellow</b>	Ambient temperature too high	Cool the crane cab
<b>Display weak</b>	Ambient temperature too high – brightness is reduced automatically	The set brightness is restored after cooling

### 14.4.15 Malfunctions on the CraneSTAR system

If an error is present, then check the fuses.



#### Risk of damage if procedure is incorrect!

Observe the following notes to avoid malfunctions and damage.

- Switch off the ignition whenever a fuse has to be replaced.
- Replace blown fuses only with new fuses of the same amperage.

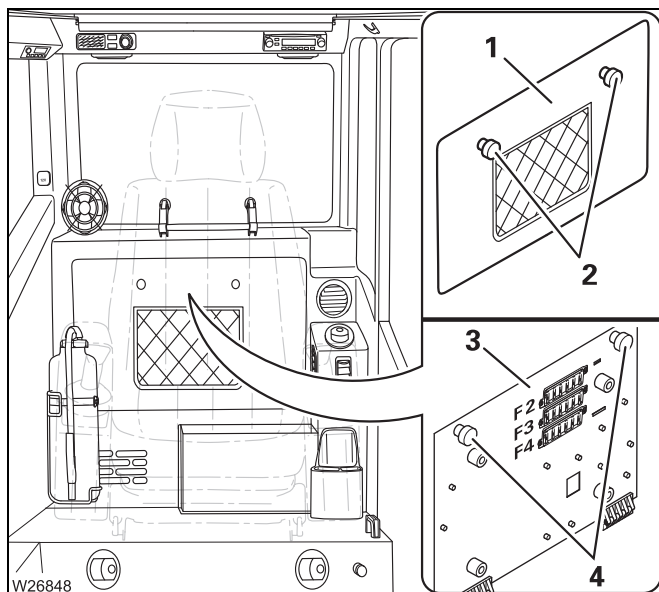

#### Fuses

- Loosen the bolts (2) and remove the cover (1).
- Check the associated fuse on the plate (3) and replace it if necessary: ▮▮▮▮▶ *Fuses in the crane cab*, p. 14 - 63.
- Loosen the screws (4) and fold down the plate (3) to the front.

### Inspections prior to telescoping

- Before telescoping, check that the following conditions are met:



#### **Risk of accidents from sudden retraction of a telescopic section!**

You can select and confirm the symbol for unlocking the telescopic section only a **maximum of 2 times**. If this does not start the unlocking procedure, contact **Manitowoc Crane Care**.

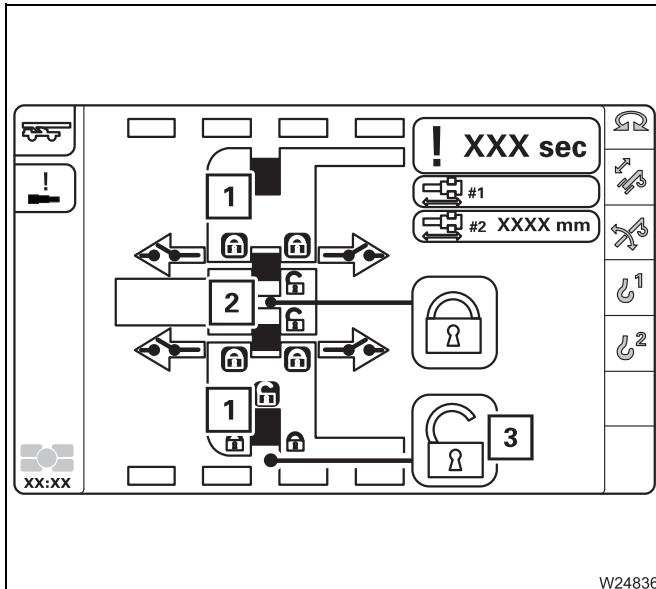

- The telescopic cylinder is at the locking point and is locked, symbols (2) are **green**.
- The telescopic section is unlocked, symbol (3) (**select no more than 2 x**), symbols (1) are **red**.

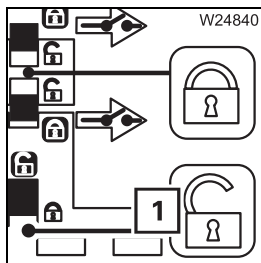

### Retracting and locking a telescopic section

During telescoping you may **not** select Lock. **Under no circumstances** select and confirm the symbol (1).



#### **Risk of damage to the main boom!**

If you select Lock during telescoping, the locking pins on the telescopic section are slid out immediately and they can damage or tear the electrical or hydraulic components in the main boom.

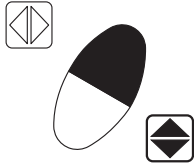
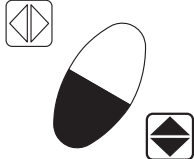
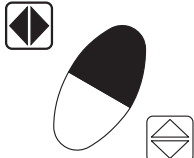
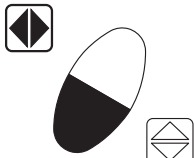

The following table shows all the button combinations. Actuated buttons are shown in black.

Button combination	Pre-selected power unit				
	Telescoping mechanism	Derricking gear	Slewing gear	Hoists	Lattice extension
 W3851	None <sup>1)</sup>	Lower boom	None	Lower	Lower boom
 W3850	Retract	Raise boom	None	Raise	Raise boom
 W3849	None	None	Slew to the right	None	None
 W3848	None	None	Slew to left	None	None

<sup>1)</sup> If the telescoping cylinder is unlocked, it will extend.



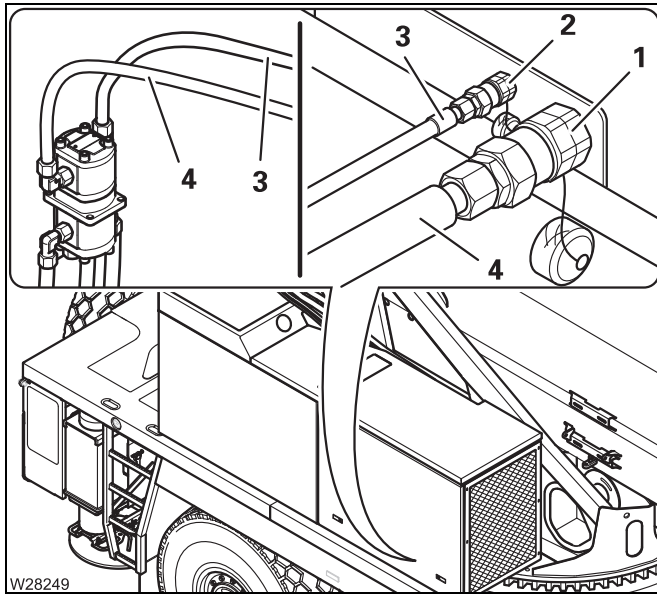

### On the superstructure

- Connect the thicker hose (4) to the connection (1).
- Connect the thicker hose (3) to the connection (2).

### Disconnecting connections

After the emergency operation, you must disconnect the hoses and the transformer.

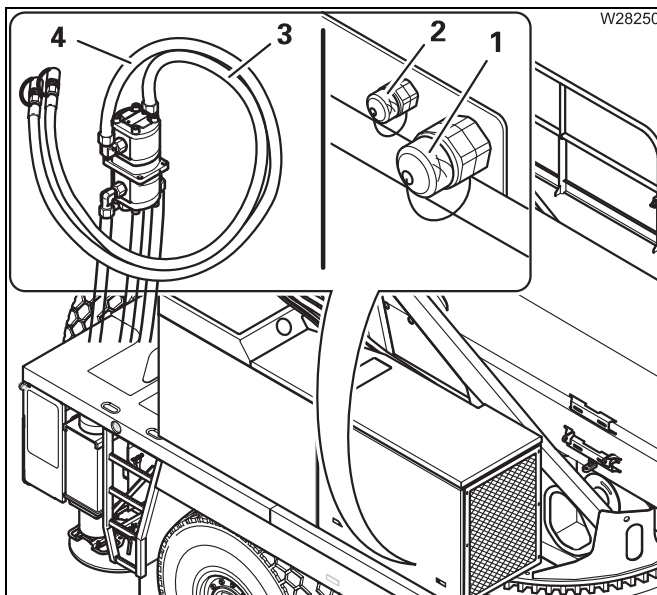

### On the superstructure

- Remove the hoses (3) and (4) from the connections (1) and (2).
- Close off the hoses and connections with the caps.



## 14.8

### Fuses in the crane cab

The fuses are located in the crane cab behind the crane cab seat.

#### Information on replacing fuses

The positions of the fuses, their designations and which functions are protected by the respective fuses are shown in the following sections.

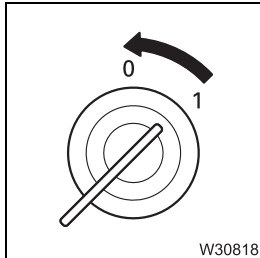

- Switch off the ignition whenever a fuse has to be replaced.



#### **Risk of damage if the ignition is switched on!**

Switch off the ignition whenever a fuse has to be replaced. This prevents the new fuse being blown immediately by the increased starting current after being installed.



#### **Risk of damage by overloading!**

Replace blown fuses only with new fuses of the same amperage. This prevents parts being overloaded and damaged or the fuse being immediately blown again. If a fuse with the same amperage fails again once the ignition is switched on, then notify **Manitowoc Crane Care**.



#### **Risk of fire!**

Never repair a blown fuse with other electrically conductive materials.



Retracting the outriggers .....	11 - 39
rigging for crane operation .....	11 - 1
Rigging the counterweight .....	11 - 74
Unrigging following crane operation .....	11 - 5
Unrigging the counterweight .....	11 - 75
Checks	
before driving .....	5 - 7
safety equipment .....	10 - 10
vehicle height .....	5 - 9
Choose a positioning site .....	11 - 9
Compressed air system	
Building up supply pressure .....	5 - 10
See brakes	
Constant speed	
See Cruise control	
Counterweight .....	11 - 67
Assembling counterweight versions .....	11 - 76
Automatic mode rigging .....	11 - 87
Automatic mode unrigging .....	11 - 89
Brief description of the operating elements .....	8 - 105
CHECKLIST	
Rigging the counterweight .....	11 - 74
Unrigging the counterweight .....	11 - 75
Counterweight combinations	
overview, version B .....	11 - 78
Counterweight sections .....	11 - 69
Extending/retracting the lifting cylinders .....	11 - 86
Identification .....	11 - 71
Open menu .....	11 - 85
Setting down for driving .....	11 - 91
Slewing with the rigged counterweight .....	11 - 93
Slinging points .....	11 - 72
Crane cab	
Adjusting the front control panel and crane cab seat .....	10 - 8
Air-conditioning system .....	10 - 149
Auxiliary air heater .....	5 - 75, 10 - 151
CraneSTAR system .....	10 - 154
door .....	8 - 148
Inclining .....	10 - 121
Operating elements	
CCS	
Start menu .....	8 - 19
Control lever configuration .....	8 - 14
On the CCS control unit .....	8 - 16
On the control panels .....	8 - 9, 8 - 12
on the hand-held control .....	8 - 77
on the outrigger control units .....	8 - 79
On the side panel	
Up .....	8 - 8, 8 - 10
Overview .....	8 - 6
Rear window .....	8 - 147

CLICK HERE TO **DOWNLOAD** THE COMPLETE MANUAL

- Thank you very much for reading the preview of the manual.
- You can download the complete manual from: [www.heydownloads.com](http://www.heydownloads.com) by clicking the link below



- Please note: If there is no response to CLICKING the link, please download this PDF first and then click on it.

CLICK HERE TO **DOWNLOAD** THE COMPLETE MANUAL