

Operating Instructions

GMK 5160

Vehicle serial number:

27.01.1997

2 085 472 en

CLICK HERE TO **DOWNLOAD** THE COMPLETE MANUAL

- Thank you very much for reading the preview of the manual.
- You can download the complete manual from: www.heydownloads.com by clicking the link below



- Please note: If there is no response to CLICKING the link, please download this PDF first and then click on it.

CLICK HERE TO **DOWNLOAD** THE COMPLETE MANUAL

1.3**Overview and contents of truck crane user information****1.3.1****Operating Instructions**

These Operating Instructions contain information required to operate the truck crane.

Chapter 2 contains the *Basic safety instructions*. Please read and observe these instructions, even if you are familiar with the safety manual. The *Basic safety instructions* are only found in this chapter. Special safety instructions that relate to specific hazards are described in the section containing the operation associated with the respective hazard.

Chapter 3 contains *Information for applications engineering*. It is intended primarily for the truck crane operator and those responsible for applications engineering.

This chapter contains

- the required qualifications of those involved in applications engineering,
- special safety instructions,
- information that is relevant to applications engineering.

Chapters 4 to 6 contain information required for *Driving the truck crane*: A description of all structural and operational components, clearly defined check lists for rigging modes and work and the operating instructions for road and off-road driving.

Chapters 7 to 10 contain information required for *Operating the crane section*, i. e. work with the truck crane: a description of all structural and operational components, clearly defined check lists for rigging modes and work, the operating instructions for individual units and a description of the various rigging procedures.

Chapter 11 contains information required to rig and operate the two-stage swing-away lattice extension, the boom extension and the auxiliary single-sheave boom top.

Chapter 12 contains information required to rig the on-the-road mode. This also includes removal and installation of the outrigger beam as well as the removal and installation of the main boom.



- two-hook operation,
- operation when crane is not on outriggers (free on wheels),
- defining SLI codes that do not correspond to the actual rigging mode,
- working with an overridden SLI,
- road driving in an unauthorized driving mode (axle load, dimension),
- moving the rigged crane in an unauthorized driving mode,
- using equipment that is not authorized for use with the crane,
- transporting passengers on unauthorized parts of the vehicle,
- carrying passengers outside the driver's cab,
- loading and unloading work, i. e. continuous operation without a corresponding break.

2.3

Organizational measures

Store the Operating Instructions and the lifting capacity table in a handy place in the truck crane.

In addition to the Operating Instructions and the lifting capacity table, observe all general, statutory and otherwise applicable regulations concerning accident prevention and environmental protection.

This includes:

- the use of hazardous materials,
- wearing protective clothing and equipment or
- traffic regulations.

Ensure that those appointed to work on the truck crane are given the information required to carry out the work before starting operations. Give your employees (e. g. banksmen, slingers, rigging personnel) appropriate instruction.

Ensure that the maintenance personnel possess the necessary know-how to safely operate the crane. Ensure that the maintenance personnel have access to the Operating Instructions.



3.2

Applications engineering

3.2.1

Application engineering requirements

Plan each application carefully. Gather information concerning the route, including in particular

- the distance,
- the route,
- overhead clearances and
- the load bearing capacity of bridges.

Gather information about the job including

- the load bearing capacity and stability of the ground (soil, buildings),
- the weight and dimensions of the loads to be lifted,
- the type of load (degree of risk involved),
- required stroke length and radius,
- restricted movement due to buildings etc.

Have the necessary equipment arranged, such as

- lifting gear,
- counterweight,
- blocks for support etc.

Organise transportation and obtain any necessary driving permits.

Poor planning leads to improvisation and improvisation is the cause of many accidents!

- | | | |
|----------|--|----------------|
| 1 | Status display for oil temperature in hydraulic system | ▣▣▣▶ p. 4 - 32 |
| 2 | Status display for supply pressure brake circuits I and II | ▣▣▣▶ p. 4 - 31 |
| 3 | Status display for automatic gearbox oil pressure | ▣▣▣▶ p. 4 - 26 |
| 4 | 24 V socket | |
| 5 | Status display for automatic gearbox oil temperature | ▣▣▣▶ p. 4 - 26 |
| 6 | Trip recorder with tachograph | ▣▣▣▶ p. 6 - 15 |

- | | |
|--|-----------------|
| 1 Warning lamp for shift lock in automatic gearbox due to malfunction | ▣▣▣▣▶ p. 4 - 26 |
| 2 Switch for driving range 1 of the automatic gearbox | ▣▣▣▣▶ p. 4 - 27 |
| 3 Switch for driving range 2 of the automatic gearbox | ▣▣▣▣▶ p. 4 - 27 |
| 4 Switch for driving range 3 of the automatic gearbox | ▣▣▣▣▶ p. 4 - 27 |
| 5 Switch for driving range 4 of the automatic gearbox | ▣▣▣▣▶ p. 4 - 27 |
| 6 Switch for driving range D of automatic gearbox | ▣▣▣▣▶ p. 4 - 27 |
| 7 Switch for driving range N of automatic gearbox | ▣▣▣▣▶ p. 4 - 27 |
| 8 Switch for driving range R of automatic gearbox | ▣▣▣▣▶ p. 4 - 28 |





Rocker switch for transfer case neutral position

May only be pressed when the vehicle is stationary and the automatic gearbox is in neutral position **N**.

Activating: Press rocker switch down.

Axle drive

The longitudinal differential locks, the transverse differential locks and the drive of the third axle line (for drive 10 x 8 only, additional equipment) may only be engaged if the level adjustment system key switch has been switched on;  p. 6 - 41.



Rocker switch for transfer case longitudinal differential lock

Locks the longitudinal differential in the transfer case.

May only be pressed when the vehicle is stationary or is moving at a speed of no more than 3 km/h.

Activate: Press rocker switch down.

Deactivate: Press rocker switch up;  p. 6 - 37.



Indicator lamp for transfer case longitudinal differential lock

Illuminates if longitudinal differential lock in the transfer case has been activated.

Goes out if longitudinal differential lock in the transfer case has been deactivated;  p. 6 - 37.



Rocker switch for longitudinal differential lock in transfer drive axle (additional equipment, only with 10 x 8 drive)

Locks the longitudinal differential in the transfer drive axle.

May only be activated when the vehicle is stationary or is moving at a speed of no more than 3 km/h.

Activate: Press rocker switch down.

Deactivate: Press rocker switch up;  p. 6 - 38.



Indicator lamp for longitudinal differential lock in transfer drive axle (additional equipment, only with 10 x 8 drive)

Illuminates if longitudinal differential lock in the transfer case has been activated.

Goes out if longitudinal differential lock in the transfer drive axle has been deactivated;  p. 6 - 38.



4.2.2

Other operating instruments in the vehicle section

Keys, doors, windows

The following keys belong to the truck crane carrier:

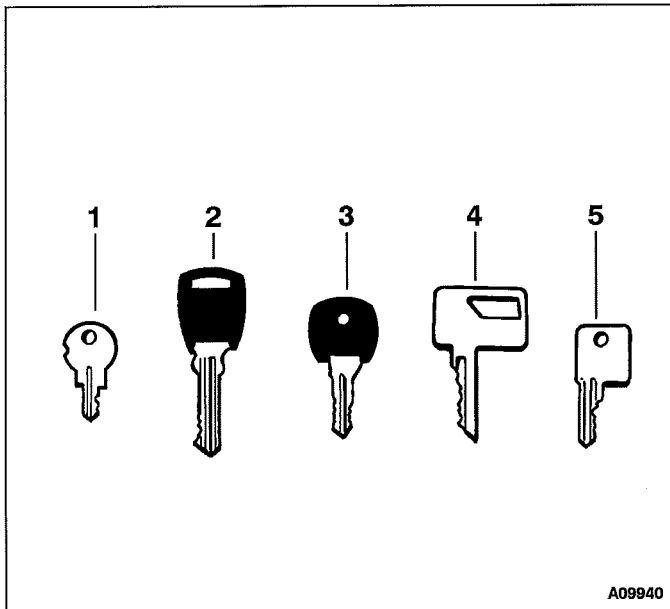

- 1 trip recorder lock
- 2 glove compartment
- 3 doors of the driver's cab
- 4 driver's cab combined lighting and ignition switch
- 5 key-operated switch for level adjustment system

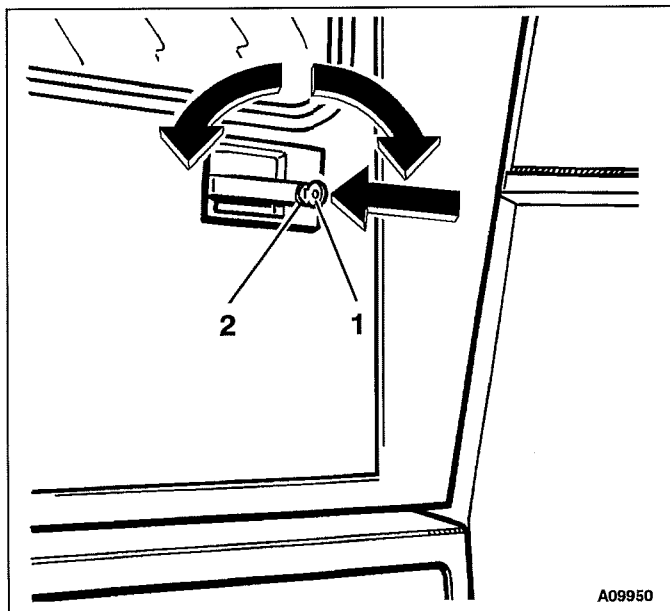

The locks on the doors of the driver's cab may be locked from the outside using the door key (1).

- | | |
|--------------------|--------------------|
| Open lock: | Turn key to right. |
| Close lock: | Turn key to left. |
| Open door: | Press knob (2). |



Checking the hydraulic oil level

Check the level of the hydraulic oil tank daily before commencing work.

This requires that:

- The truck crane is standing on a horizontal surface in on-the-road mode,
- the support is retracted,
- the truck crane is at on-the-road level.

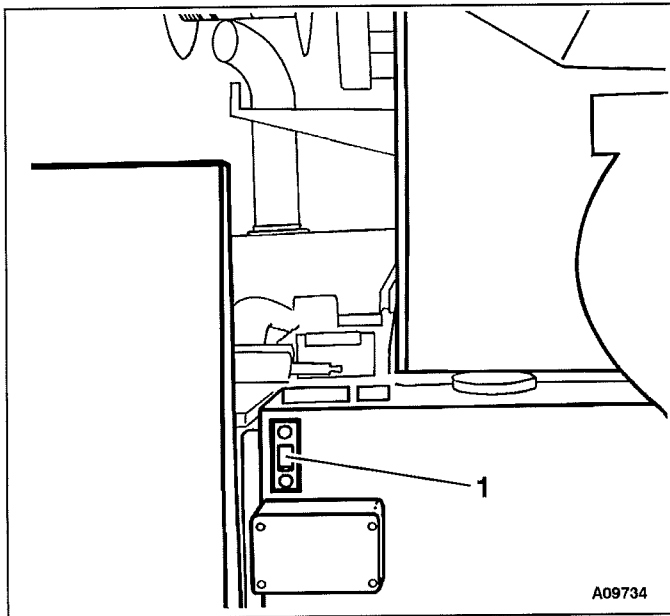

- Check the level of the hydraulic oil tank through the inspection glass. The hydraulic oil should be visible in the centre of the inspection glass when cold.



Checking the oil level when the gear oil is warm (70–90 °C)

This oil check is carried out when the oil is at operating temperature (70 to 90 °C) and the engine is running (at idling speed). It must be carried out in the following cases:

- after any correction of the oil level (topped up or drained),
- after an oil change,
- after the automatic gearbox has been repaired.



The warm oil check is definitive. It should be carried out whenever there is any doubt that the oil is at the correct level!

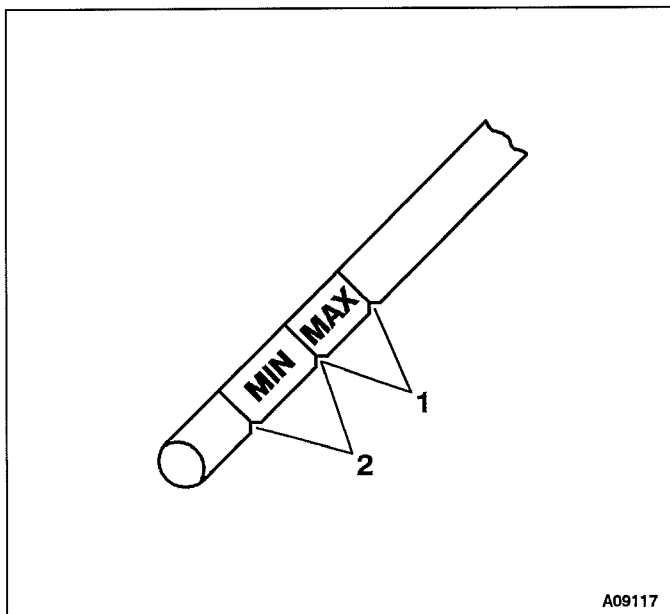

- First check the oil level when the oil is cold and correct if necessary.
- Press the service brake pedal right down and change into driving range **D** so that the oil heats up more quickly.
- Check the oil level at an operating temperature of 70 to 90 °C (indicated on the front instrument panel). The oil must be in the “warm range” (1).
- Top up oil through the dipstick tube or bleed it off as required. Data concerning the prescribed oil specification  Maintenance Manual.

Checking the suspension

- Check whether the suspension locking system is activated.



The *Suspension locking system* indicator lamp should illuminate when suspension is locked.

Press the *Suspension locking system* rocker switch upward when the *Suspension locking system* indicator lamp illuminates.



If the air pressure in the secondary consumer circuit decreases below 5 bar, the suspension will be locked and the *Suspension locking system* indicator lamp will illuminate, even if the suspension locking system is switched off.



Be careful not damage the axle lines!

The suspension must not be locked during on-road driving! The steering behaviour may also change when the suspension is locked.



The suspension is always locked when the ignition is switched off.

Checking the on-the-road level

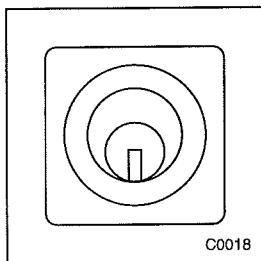

- Insert the key into the *Level adjustment system* key switch. Turn the key to the right, push it in and turn it back to the left.



The *No on-the-road level* indicator lamp must not illuminate during on-road driving.

If the *No on-the-road-level* indicator lamp does illuminate, you must move the truck crane into *On-the-road-level* position;  *Level adjustment system*, p. 6 - 44.



6.2

General operation

6.2.1

Operation of the automatic gearbox

Driving ranges of the automatic gearbox

You may choose between the various driving ranges of the automatic gearbox using the selector switches.



Danger of damage to the gearbox!

Only switch between the driving ranges

D and **R** when the truck crane is stationary!

Never shift into driving range **N** (neutral) while on the move.

Otherwise, you could lose control of the truck crane!

Do not drive long distances in reverse. When travelling in reverse the oil pump in the transfer case does not function.

When the diaphragm push button is depressed, a light engagement of the button should be felt. The indicator lamp in the button lights up and an acoustic signal indicates that the gearbox has switched to the selected range.



Each time the carrier engine is started, all indicator lamps in the selector switch panel illuminate for a few seconds. Replace any defective lamps immediately.



Switch for neutral position N of automatic gearbox = neutral gear

Switch the automatic gearbox into neutral position to start the vehicle engine. Only in this position can the vehicle engine be started. The parking brake or service brake must be used to brake the truck crane in neutral position, as the crane could otherwise start to roll.



Danger of damage to the gearbox if the truck crane is allowed to roll!

Never switch the automatic gearbox into neutral position while driving as this could damage the automatic gearbox. Moreover, the retarder does not work in neutral position.



6.2.3 Driving on downhill slopes

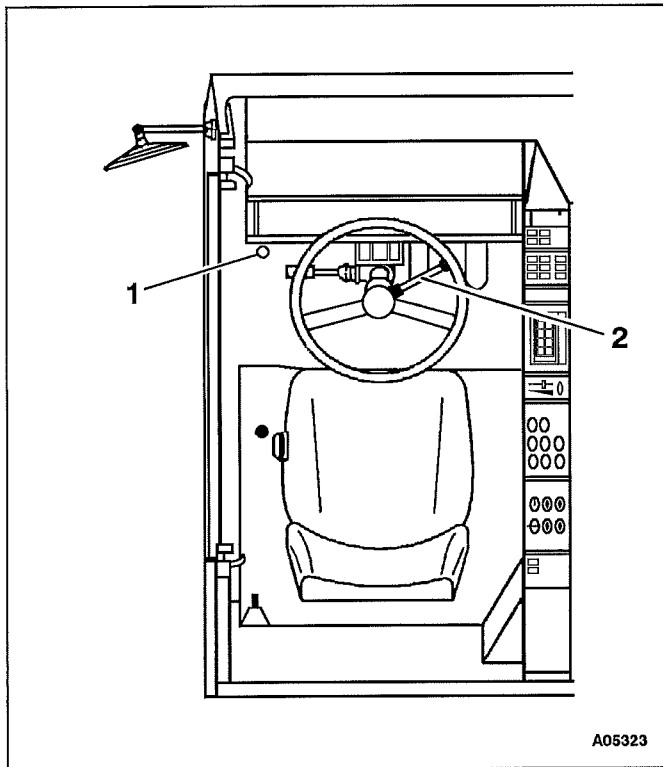

The retarder of the automatic gearbox can be used when driving downhill in every driving range.

- Release the accelerator and press the *Retarder* foot-operated switch (1).

You can in addition brake the vehicle with the *Telma* eddy current retarder (additional equipment).

- For this operate the *Telma eddy current retarder* switch (2);  *Telma eddy current retarder* in this section, p. 6 - 30.

Retarder of the automatic gearbox

It is also possible to switch to a lower driving range and to driving mode **P** to increase the retarder braking force in the automatic gearbox.

As long as the retarder in the automatic gearbox is switched on, the gearbox cannot shift upwards.



If you press the accelerator while the retarder switch is being operated, the automatic gearbox retarder switches off and the gears can shift upwards. You should therefore select a lower driving range when driving downhill in order to avoid inadvertent upward shifting.



The gearbox can in spite of this shift upward. An overspeed protection is built into the automatic gearbox, which automatically switches into a higher gear, even if a lower driving range has been selected. Keep the engine speed below 2200 rpm.

Switching to a lower driving range:

- Brake the truck crane to the corresponding speed. The engine speed must be below 2200 rpm in the lower driving range.



6.3.4

Drive of the third axle line

The drive of the third axle line can only be switched on in off-the-road gear and when the key switch of the level adjustment system is actuated. The truck crane then drives in driving ranges **1**, **2** and **R** only.



The drive of the third axle line should only be switched on or off when the vehicle is stationary. The drive of the third axle line may not be switched on when driving around corners on solid ground. It is therefore imperative that you switch off the drive of the drive axle line when driving on solid ground.

Activating the drive



- Stop the truck crane or let it roll at a maximum speed of 3 km/h.
- Switch the automatic gearbox to neutral position **N**.



- Straighten the steering.
- Engage the off-the-road gear.



- Actuate the level adjustment system key switch.
- Switch on the *Drive of the third axle line* rocker switch.



- Carefully start the vehicle, until the *Drive of the third axle line* indicator lamp illuminates.

Deactivating the drive



- Stop the truck crane or let it roll at a maximum speed of 3 km/h.
- Switch the automatic gearbox to neutral position **N**.



- Switch off the *Drive of the third axle line* rocker switch.
The *Drive of the third axle line* indicator lamp goes out when the drive of the third axle line is switched off.



Totally switch off the drive of the third axle line with *Drive of the third axle line* rocker switch!

Do not use the level adjustment system key switch!

This prevents improper shifting and possible damage in the axle central drive.

If the *Drive of the third axle line* indicator lamp continues to illuminate although the drive of the third axle line has been switched off, the drive has not yet been deactivated. You may expedite the deactivation of the drive by slowly driving forward and backward.



The wheels of the first, second and third axle lines are steered with the steering wheel.



Accidents may occur if the steering of the fourth axle line is unlocked during on-road driving!

After driving in all-wheel steering mode, return the truck crane immediately to normal driving mode with the steering lock engaged at the fourth axle line and the drag rods connected between the third and fifth axle lines. The normal driving mode is reestablished when the *Separate steering release* indicator lamp is extinguished.

6.4.3

Detaching fourth and fifth axle line, locking steering of fourth axle line

For on-road travel

- the fourth axle line steering must be locked,
- the drag rods of the third and fifth axle lines must be connected with one another.



Accidents may occur if the steering of the fourth axle line is unlocked during on-road driving!

Normal steering mode with locked steering on the fourth axle line is not activated until the *Release separate steering* indicator lamp has gone out.

- Turn the wheels of the front axle lines as far as possible to the left or right using the steering wheel.



If the wheels on the front axle lines are not turned as far as they will go the steering lock on the fourth axle line cannot be engaged.



- Press the *Release separate steering* rocker switch up.



The *Release separate steering* indicator lamp remains illuminated.

The drag rods of the third and fifth axle lines must be connected to each other first.



Connecting supply cables

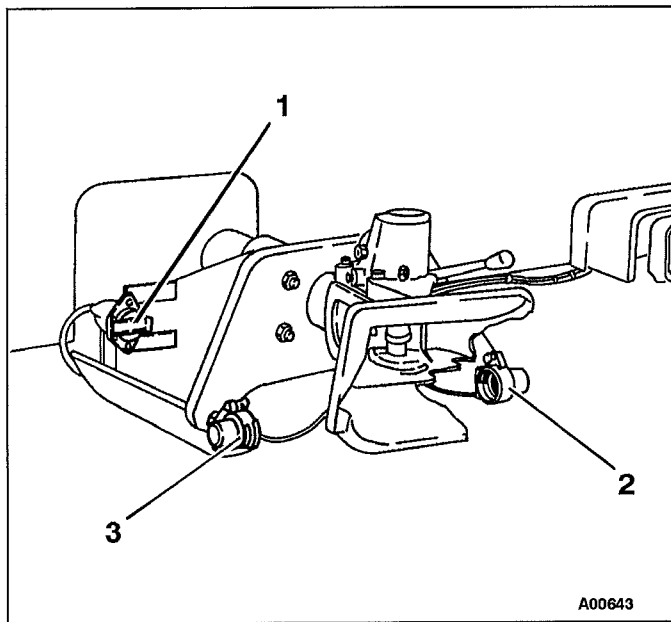

- Insert the plug of the trailer's electrical system into the socket (1). Plug the ABS connection cable (if one is attached) into the appropriate socket (additional equipment).
- First connect the hose of the brake cable to the yellow coupling head (3).
- Subsequently connect the hose of the supply cable to the red coupling head (2).



Accidents may occur if the hoses are too short or incorrectly positioned!
The hose lines must not come off when driving around corners. When connecting the hoses, ensure that the length is sufficient and that the hoses have enough clearance.

- Check the function of the trailer's direction indicators and light system.
- Test the service brake and the parking brake immediately after setting off.

Removing the supply lines



Accidents may occur if these steps are not carried out in the proper order!
It is imperative that the hoses be disconnected in the order specified above. If the hose for the brake line is disconnected first, the trailer brake will be released and the trailer will begin to roll.

- Remove the plug of the trailer's electrical system from the socket (1). Pull the ABS connection cable (if one is attached) out of the appropriate socket.



- | | | |
|-----------|---|-------------|
| 1 | Warning lamp for charge indicator | ➡ p. 7 - 26 |
| 2 | Indicator lamp for crane motor air filter | ➡ p. 7 - 43 |
| 3 | Warning lamp for hydraulic oil filter in feed pump | ➡ p. 7 - 42 |
| 4 | Warning lamp for high oil temperature in slewing gear brake | ➡ p. 7 - 33 |
| 5 | Warning lamp for crane engine oil pressure | ➡ p. 7 - 27 |
| 6 | Warning lamp for hydraulic oil filter in control pressure pump | ➡ p. 7 - 42 |
| 7 | Rocker switch with indicator lamp for additional heating | ➡ p. 7 - 45 |
| 8 | Rocker switch for hoist rope control spotlight
(additional equipment) | ➡ p. 7 - 43 |
| 9 | Rocker switch for left-hand working headlight socket | ➡ p. 7 - 43 |
| 10 | Rocker switch for right-hand working headlamp socket | ➡ p. 7 - 43 |
| 11 | Dimmer for instrument panel lighting/instrument panel lamp | |
| 12 | Rocker switch for windscreen wiper | ➡ p. 7 - 43 |
| 13 | Rocker switch for roof window wiper | ➡ p. 7 - 44 |
| 14 | Rocker switch for intermittent wiper operation,
windscreen and roof window | ➡ p. 7 - 44 |
| 15 | Rocker switch for windshield wiper/washing system | ➡ p. 7 - 44 |
| 16 | Indicator lamp for SLI shutdown | ➡ p. 7 - 40 |
| 17 | SLI early warning lamp | ➡ p. 7 - 40 |
| 18 | Warning lamp for lifting limit switch shutdown | ➡ p. 7 - 30 |
| 19 | 24 V socket | |
| 20 | Ignition lock for crane engine | ➡ p. 7 - 43 |
| 21 | Crane engine starter switch | ➡ p. 7 - 26 |
| 22 | Crane engine stop switch | ➡ p. 7 - 26 |
| 23 | Status display for fuel reserve | ➡ p. 7 - 27 |
| 24 | Status display with warning lamp for temperature of
crane engine coolant | ➡ p. 7 - 26 |
| 25 | Status display for hydraulic system oil temperature | ➡ p. 7 - 42 |



Blank page

Counterweight lifting gear

Counterweight p. 10 - 33

Display and operating instruments in the crane cab



Indicator lamp for locked counterweight

Illuminates when the pins for locking the counterweight to the superstructure are extended.



Indicator lamp for unlocked counterweight

Illuminates when the pins for locking the counterweight to the superstructure are retracted.

Display and operating elements in the switch unit



Switch for retracting counterweight lifting cylinders

In order to retract the counterweight lifting cylinders this switch must be held down.



Switch for extending counterweight lifting cylinders

In order to extend the counterweight lifting cylinders this switch must be held down.



Switch for extending tilt cylinders

The tilt cylinders push the counterweight cylinders upwards.

Extend tilt cylinders: keep switch pressed down.

Retract tilt cylinders: release switch.



Knob for locking/unlocking locking pins

Locks the counterweight to the superstructure.

Lock counterweight: Turn knob to left.

Unlock counterweight: Turn knob to right.



Indicator lamp for locked counterweight

Illuminates when the pins for locking the counterweight to the superstructure are extended.



Indicator lamp for unlocked counterweight

Illuminates when the pins for locking the counterweight to the superstructure are retracted.





Membrane switch with indicator lamp for angle of main boom

After pressing the key, the green indicator lamp in the key lights up and the current main boom angle is shown in the *Information* status display. The red warning light in the key has no function.



Membrane switch with indicator lamp for length of main boom

After pressing the key, the green indicator lamp in the key lights up and the current main boom length is shown in metres in the *Information* status display. No differentiation is made in the status display between fixed and intermediate or telescoping lengths.



Membrane switch with indicator lamp for height of single-sheave boom top

After pressing the key, the green indicator lamp in the key lights up and the current height of the single-sheave boom top of the main boom or the lattice extension is shown in metres in the *Information* status display. The height displayed relates to the bottom axle of the boom and the lower head sheave axle. Any deflection of the boom is ignored.



Membrane switch with indicator lamp for angle of lattice extension

After pressing the key, the green indicator lamp in the key lights up and the current angle of the lattice extension from the horizontal is shown in the *Information* status display.



Membrane switch with indicator lamp for degree of utilization

After pressing the key, the green indicator lamp in the key lights up and the current degree of utilization, relative to the maximum load shown and the actual load is shown as a percentage in the *Information* status display.



Without function.

After pressing the switch, the value shown in the *Information* status display does not change. No lamps illuminate in the key.



Membrane switch with indicator lamp for hydraulic oil pressure in derricking cylinder lower chamber

After pressing the key, the green indicator lamp in the key lights up and the current hydraulic oil pressure at the piston surface of the derricking cylinder is shown in bar in the *Information* status display.



Membrane switch with indicator lamp for hydraulic oil pressure in derricking cylinder upper chamber

After pressing the key, the green indicator lamp in the key lights up and the current hydraulic oil pressure at the surface of the piston ring in the derricking cylinder is shown in bar in the *Information* status display.



Seat adjustment

You may adjust the hydraulically spring-mounted seat in the crane cab to your respective height and weight.

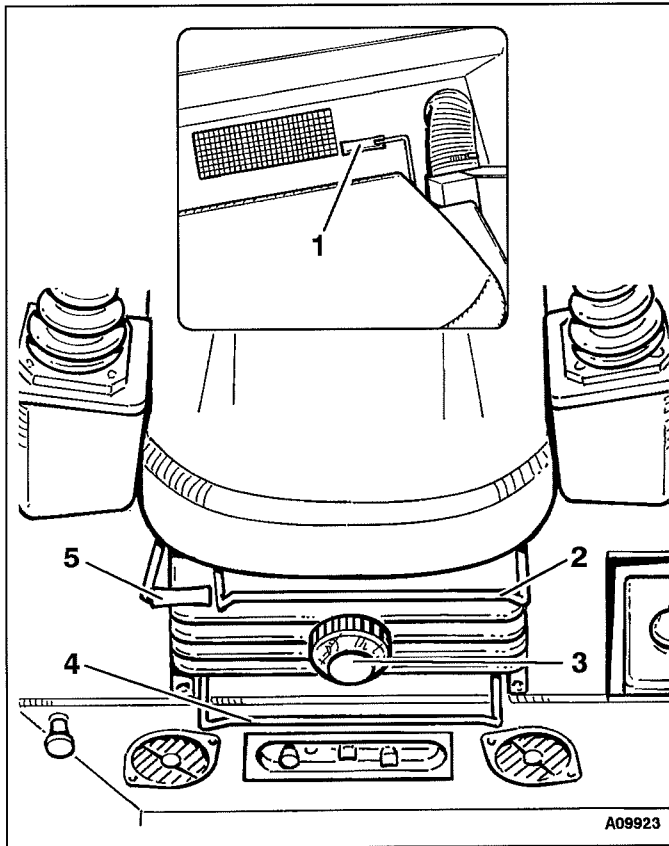

- 1 angle of the back rest, unlocking of the left armrest console
- 2 backward/forward adjustment of the seat and the back rest without the control consoles
- 3 adjusting the suspension stiffness to your weight in kg
- 4 backward/forward adjustment of the entire seat including the control consoles
- 5 angle of the seat

Topping up engine oil

Data concerning the prescribed oil specification may be found in the Mercedes-Benz operating manual.

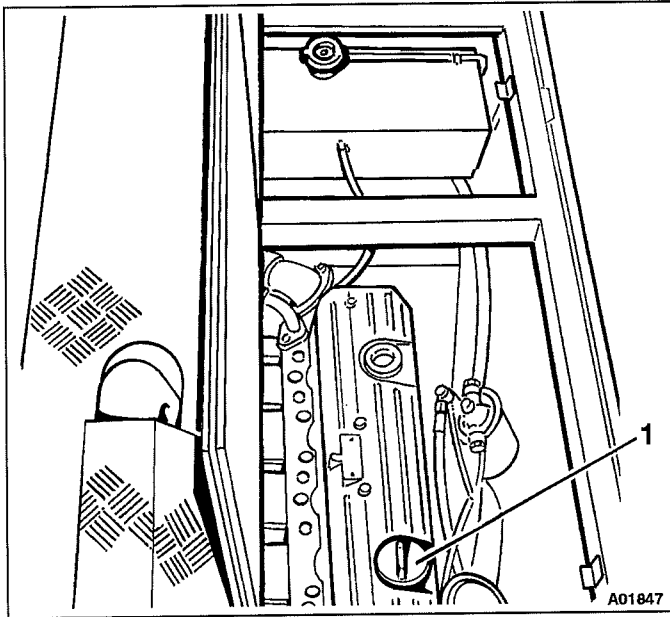

The oil filler-neck (1) of the crane engine is under the cover plate beside the exhaust pipe.

- Fill the engine oil through the filler neck (1).

Checking the coolant level

Information concerning the prescribed coolant agents may be found in the supplied Maintenance Manual.

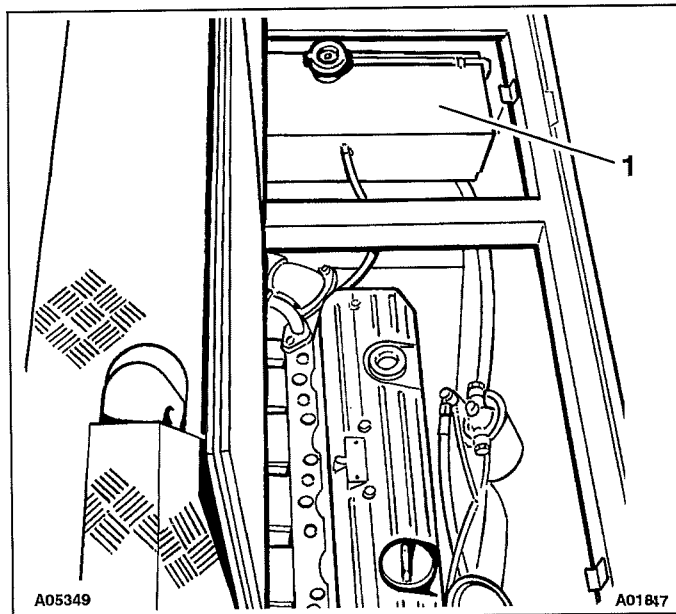

The coolant reservoir (1) is located on the right side of the carrier above the engine coolant heat exchanger.

27.01.1997



9 Crane operation

9.1 Checking the truck crane before working with the crane

9.1.1 CHECK LIST: When truck crane is rigged



This check list only applies if the truck crane has been rigged and is on the site.

If the truck crane is not yet rigged, you must proceed according to the *CHECK LIST: Rigging*; p. 10 - 3

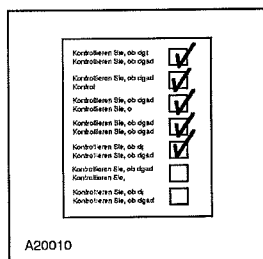

1. Carry out the required inspections and tasks before starting the crane engine; *CHECK LIST: Starting the crane engine*, p. 8 - 3, Items 1 - 6.



2. The suspension system is locked; *Locking the suspension system*, p. 10 - 20.

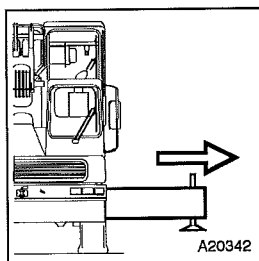

3. All four outrigger beams are extended to the necessary span; *Supporting spans*, p. 10 - 18.

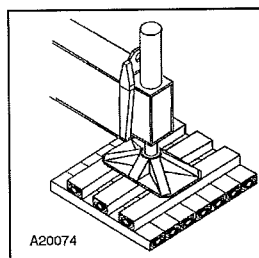

4. The outrigger pads are propped in such a way that the outrigger pressures that occur during crane work cannot exceed the load bearing capacity of the ground under any circumstances; *Load bearing capacity of the ground and the outriggers*, p. 10 - 9.

27.01.1997



9.2 Operating the safe load indicator



The *SLI-early warning* and *SLI-shutdown* warning lamps are duplicated: In the left module of the instrument panel and in the SLI. The appropriate warning lamps always illuminate simultaneously. In the SLI operational instructions which follow, only the instrument panel symbols in the SLI are shown.

9.2.1 Switching on the SLI

Switching on

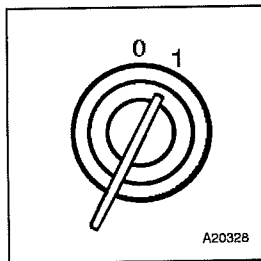

The SLI is switched on with the ignition.

- A test programme is run in the SLI in the first 5 seconds. During this time
- the *SLI early warning* and *SLI shutdown* warning lamps illuminate,
 - the numbers in the displays constantly change or flash and
 - an acoustic signal (continuous buzzer tone) sounds.

The test programme also runs after every voltage drop, e. g. when starting the engine.



After completion of the test programme

- the *SLI shutdown* warning lamp illuminates,
- the *SLI early warning* warning lamp illuminates,
- the continuous buzzer tone continues to sound.

Different numbers are shown in the *Working position* and *Rigging* status displays, depending on the length of time for which the SLI was switched off:

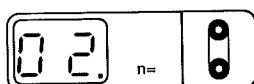

- If the SLI was only switched off briefly, the last settings and the signalling point are shown in both displays.



Optional status displays

You can have the the information listed in the following section shown in the *Information* status display.

- To do this, press the appropriate membrane switch. The green indicator lamp in the membrane switch lights up and the current value appears in the *Information* status display.

If a different membrane switch was pressed before the selection was made, the green indicator lamp in the membrane switch goes out and the displayed value changes.



- Permissible slewing range in degrees with the *Slewing angle* membrane switch



- Current main boom angle in degrees with the *Main boom angle* membrane switch



- Current main boom length in metres with the *Main boom length* membrane switch



- Current height of the single-sheave boom top in metres with the *Height of single-sheave boom top* membrane switch



- Current angle of the lattice extension in degrees with the *Angle of lattice extension* membrane switch



- Current degree of utilization with the *Degree of utilization* membrane switch



- Current hydraulic oil pressure in the lower chamber of the derricking cylinder in bar with the *Hydraulic oil pressure in derricking cylinder lower chamber* membrane switch



- Current hydraulic oil pressure in the upper chamber of the derricking cylinder in bar with the *Hydraulic oil pressure in derricking upper chamber* membrane switch

More detailed information on the respective displays Chapter 7.2 *Description of the functions of the display and operating display and operating elements.*



If a selector key which has no function assigned to it is pressed, the value in the *Information* status display does not change and the green indicator lamp in the key does not light up.

SLI early warning



If the actual load amounts to approximately 95 % to 100 % (depending on the regulations of the country in question) of the maximum permissible load or more, the *SLI early warning* warning lamp lights up. The intermittent buzzer tone sounds at the same time.



- Press the *Acknowledge* switch to switch off the buzzer tone.

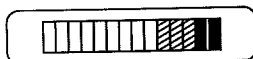

The load is shown in the *Degree of utilization* status display. The green and yellow LED's light up.



9.3.2

Hoists

Main hoist

You may work with the main boom or the lattice extension using the hoist rope on the main hoist.



You will find information for two-hook operation in chapter *Two-hook operation*, p. 11 - 85.



Accidents may occur due to the inadvertent operation of a hoist!

Always switch off the hoist that is not in use!

You may no longer turn the drum if the hook block is unreeved and you have reeled the hoist rope in completely.

- If the hoist rope is inadvertently turned in the lowering direction, the switching point of the lowering limit switch is displaced, resulting in slack rope. This causes rope loops to form on the hoist drum which can lead to load slipping and damage to the hoist rope!
- If the hoist rope is inadvertently turned in raising direction, the switching point of the lowering limit switch changes, leaving less than the required number of safety windings on the drum.



- Switch on the main hoist.

Press up the *Deactivate main hoist* rocker switch on the right-hand control lever.



- Check that the two-hook operation is switched off.

The *Two-hook operation* rocker switch on the left-hand control lever must be pressed down.



- Check whether auxiliary hoist (additional equipment) is switched off. The *Two-hook operation* rocker switch on the left-hand control lever must be pressed down to prevent inadvertent use of the auxiliary hoist.



You can operate the main hoist with the critical load control on or off; p. 9 - 51.



The hoist gear speed is reduced automatically in the critical load range when the critical load control is switched on.

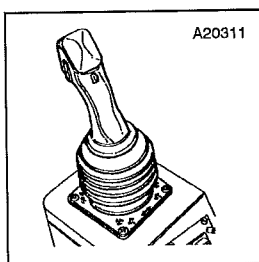

Raise: Pull right-hand control lever back.

Lower: Push right-hand control lever forward.

You may regulate the telescoping speed by moving the control lever and changing the engine speed using the accelerator or choke throttle lever.



The following percent values represent main boom fixed lengths:

- Telescope section I: 0 / 100
- Telescope section II: 0 / 50 / 100
- Telescope section III: 0 / 50 / 75 / 100
- Telescope section IV: 0 / 50 / 75 / 100

All other percent values represent main boom intermediate lengths and main boom telescoping lengths.

Example:

Telescope status display for main boom **intermediate lengths** and main boom **telescope lengths**.

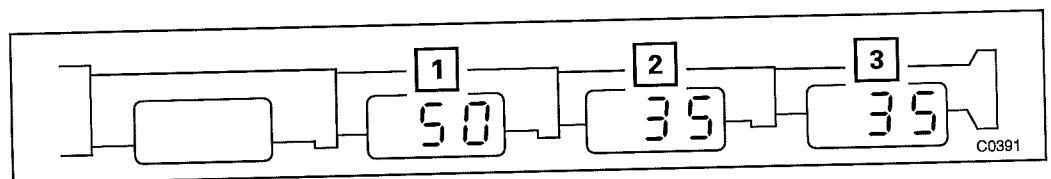

- Telescope section I (1) 100 % extended (fixed length)
- Telescope section II (2) 100 % extended (fixed length)
- Telescope section III (3) 35 % extended (intermediate length)
- Telescope section IV (4) 35 % extended (intermediate length)

The following percent values represent main boom **intermediate lengths** and main boom **fixed lengths**:

- Telescope section I: must be locked
- Telescope section II: 0–50 and 50–100
- Telescope section III: 0–50 and 50–75 and 75–100
- Telescope section IV: 0–50 and 50–75 and 75–100



The maximum lifting capacity permitted also constantly changes in the *Maximum load* status display.

If the telescope sections are put in a telescope status in which main boom fixed length values, intermediate length or telescoping length values are not permitted, the maximum permitted lifting capacity is reduced to the unloaded hook values from 0.6 t to 3.0 t.



9.4

Driving a rigged crane

This section describes moving the truck crane with an installed counterweight.



Risk of accidents!

It is forbidden to move the truck crane with a suspended load.
Put the load down before you move the truck crane.
Secure the hook block so that it cannot swing.



Danger of overturning!

Before the crane may be driven when it is rigged the superstructure must be locked and the slewing gear permanent brake must be engaged.

9.4.1

Driving route

The route must be a flat, even surface. The level adjustment system cannot compensate for uneven surfaces. If the surface pressure of the tyres exceeds the permissible load on the ground, the surface pressure must be increased using packing made of durable material (e. g. wooden planks).



Be careful not to damage the tyres!

Release the air from the tyres. Do not reduce the tyre pressure!

9.4.2

Position of the boom

The truck crane may only be moved if certain conditions are met. The boom may have to be moved to a certain position, depending on the counterweight mounted.



Be careful not to damage to the axle lines!

Always move the boom to the prescribed position before you move the rigged truck crane. The permitted load on the axle lines will be exceeded if the boom is in a position which deviates from the prescribed position.



CLICK HERE TO **DOWNLOAD** THE COMPLETE MANUAL

- Thank you very much for reading the preview of the manual.
- You can download the complete manual from: www.heydownloads.com by clicking the link below



- Please note: If there is no response to CLICKING the link, please download this PDF first and then click on it.

CLICK HERE TO **DOWNLOAD** THE COMPLETE MANUAL

Table of Contents

10	Rigging work	10 - 3
10.1	Check lists for rigging work for crane operation with main boom	10 - 3
10.1.1	CHECK LIST: Rigging	10 - 3
10.1.2	CHECK LIST: Unrigging	10 - 6
10.1.3	CHECK LIST: During the winter	10 - 8
10.2	Choosing a suitable site	10 - 9
10.2.1	Load bearing capacity of the ground and the outriggers	10 - 9
10.2.2	Safe distance from banks and pits	10 - 12
10.2.3	Safe distance from electrical lines	10 - 12
10.2.4	Earthing the truck crane	10 - 13
10.3	Outriggers	10 - 15
10.3.1	CHECK LIST: Extending the outriggers	10 - 15
10.3.2	CHECK LIST: Retracting the outriggers	10 - 17
10.3.3	Supporting spans	10 - 18
10.3.4	Preparing outriggers	10 - 20
10.3.5	Extending/retracting the outrigger beams	10 - 22
10.3.6	Moving the outrigger pads into working/driving position	10 - 27
10.3.7	Extending/retracting the outrigger cylinders	10 - 29
10.4	Counterweight	10 - 33
10.4.1	Identification of counterweight parts	10 - 33
10.4.2	Counterweight versions	10 - 34
10.4.3	Slings and locking devices	10 - 37
10.4.4	CHECK LIST: Rigging counterweight	10 - 38
10.4.5	Preparing truck crane for mounting of counterweights	10 - 39
10.4.6	Slings counterweight	10 - 40
10.4.7	Counterweight lifting gear	10 - 42
10.5	Rigging work on the main boom	10 - 47
10.5.1	Safety rope	10 - 47
10.5.2	Hook block in the holder on the carrier	10 - 48
10.5.3	Hook block on a separate vehicle	10 - 52
10.5.4	Reeving and unreeving the hoist rope	10 - 54
10.5.5	Possible reeving methods on the main boom	10 - 59
10.5.6	Anemometer (additional equipment)	10 - 61

Always align the packing horizontally. Always align the truck crane horizontally with the outrigger cylinders.



| The truck crane may overturn if it is standing on an incline.

Enlarging the surface area of the outrigger

Only use durable materials for the packing, such as

- thick wooden planks or square timber made of hardwood (such as bongossi, etc.)
- thick steel plates with soldered webs that prevent the outrigger pads from slipping or
- wide steel profiles soldered together (girders) with soldered webs to prevent the outrigger pads from slipping.



| Accidents may occur if the crane overturns due to weak packing!

Thin boards or planks made of pine wood or bricks are not made to withstand the resulting pressure and divert it into the ground.

Wooden planks and square timber must be at least 80 mm high. They must be knotless and free of fractures.

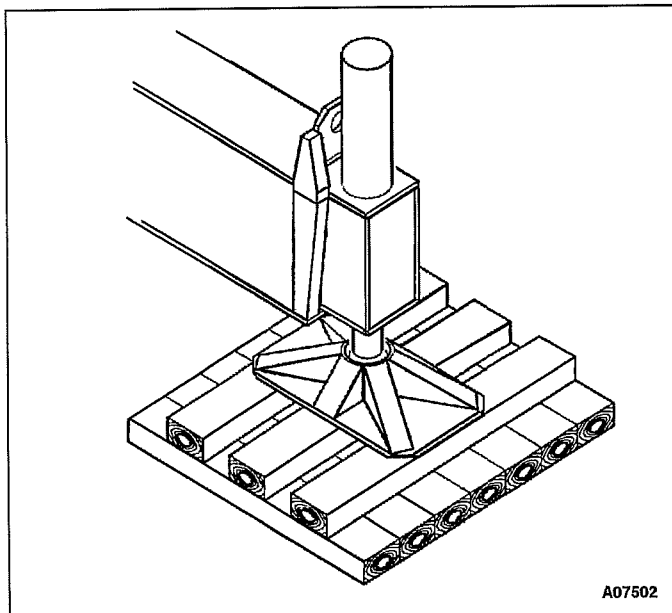

Please note the illustration to the left when constructing the packing.

The materials used must have the same height in every layer.

The layers must be offset from the following layer by 90°.

Consult your supervisor if you are in doubt.

Position of the yoke

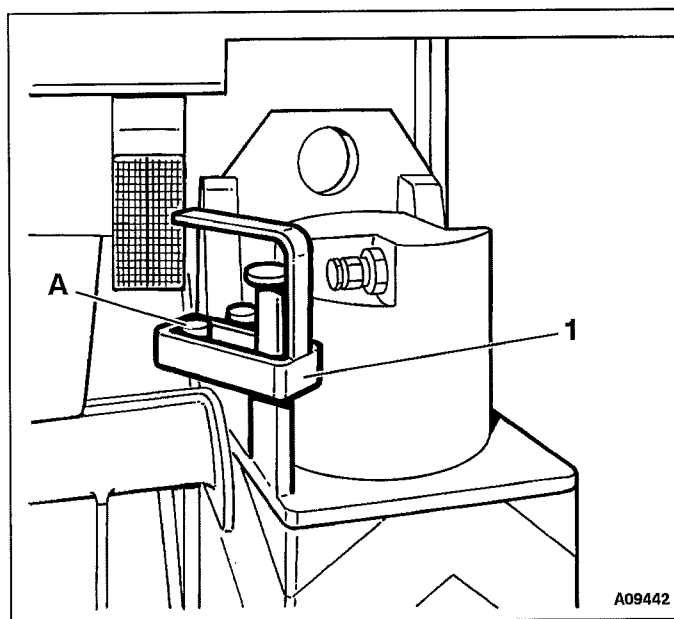

The outrigger beams are secured against slipping out at position **A** of the yokes (1) on each of the four outrigger beams. At position **A**, the inner outrigger beams are connected to the crane carrier.

The outrigger beams can be extended to two spans (5.40 or 8.20 m). The prescribed span may be found in the *Lifting capacity table*.

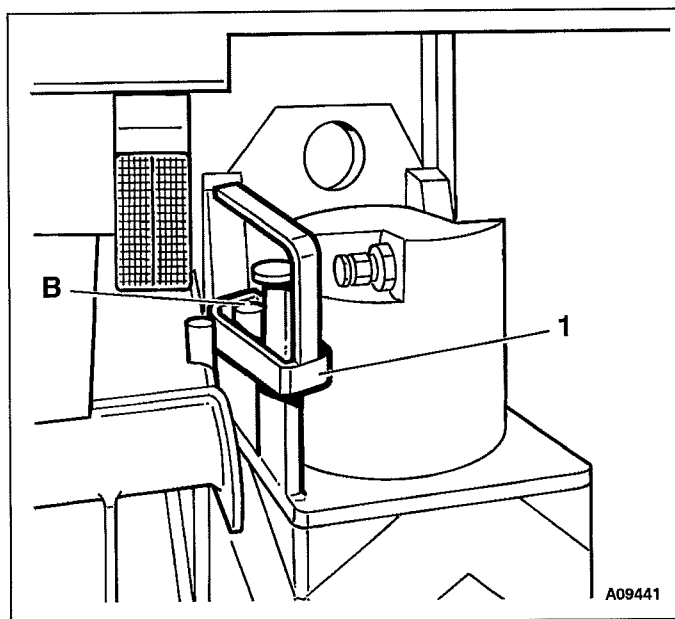

Preparing the outrigger for the 5.40 m span

- Move the yoke (1) on each of the four outrigger beams to position **B**. At position **B**, the internal outrigger beams are connected to the outer outrigger beams.



Retracting the outrigger cylinders



Accidents may occur when outrigger movements are performed outside of your field of view!

Monitor the movements of the outrigger cylinders closely or have a banksman monitor the movements during operation.

No one may be in the area of danger from moving outrigger beams.

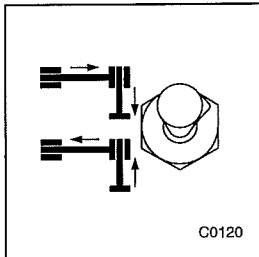

C0120

- Press the *Preselection of direction of outrigger movement* toggle switch down.

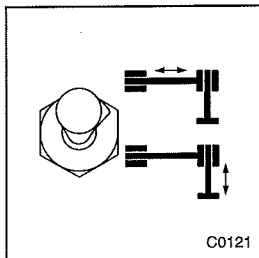

C0121

- Press the *Preselection of outrigger cylinder/outrigger beam* toggle switch down.

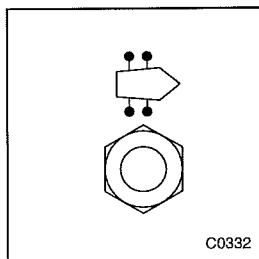

C0332

Retract all four outrigger cylinders one after the other.

- Press the *Outriggers* central toggle switch down.

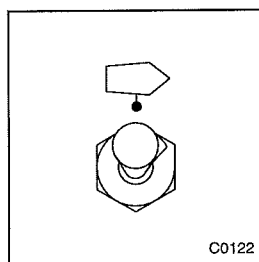

C0122

- In addition, press the toggle switch for the desired outrigger cylinder (e. g. front right).

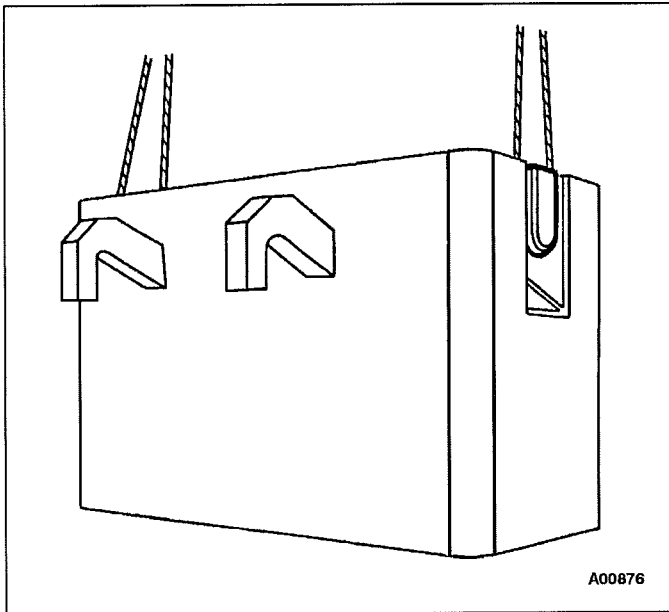

Each 7.5 t counterweight block (additional equipment) has two attachment points at which the lifting gear is attached.

Stacking counterweight sections

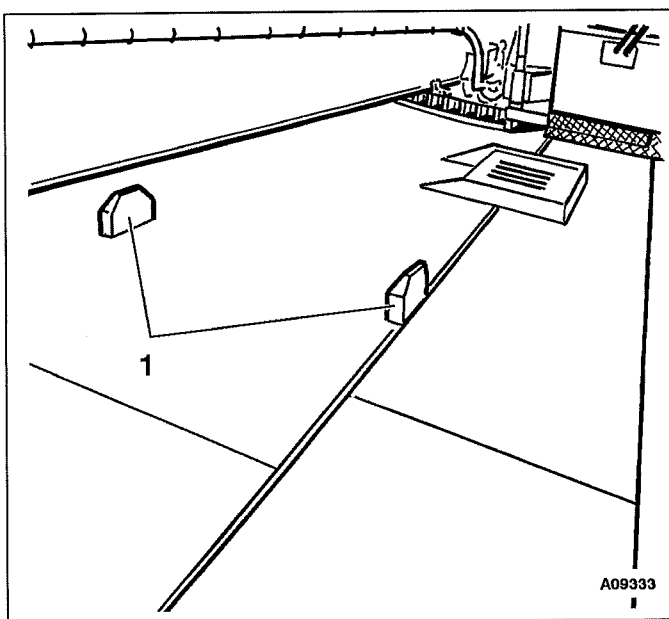

Before rigging, the counterweight sections are stacked on the carrier. For every counterweight version the 3.2 t counterweight section with lifting rack must first be positioned between the guide plates (1) on the counterweight platform.



Risk of crushing!

Ensure that helpers maintain sufficient clearance from counterweight sections with all parts of their bodies during stacking.

Remove all objects which could be jammed or crushed by counterweight sections.

Risk of accidents!

Remaining under suspended counterweight sections is not permitted!

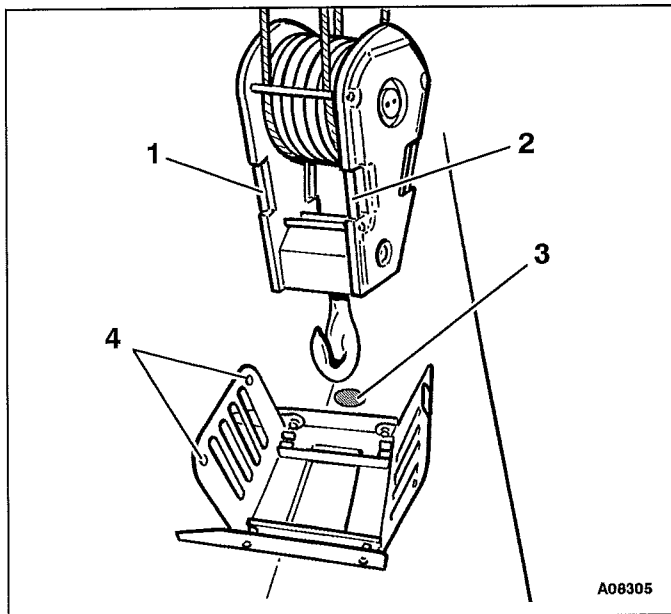

- Continue lowering the hook block until the hook touches the point marked (3) on the crane carrier.
- A helper can guide the hook block using handles (1) and (2) when the hook block is lowered further.



Risk of crushing!

The hook block may only be guided in this way using the two handles (1) and (2) facing away from the turntable. The hook block must on no account be guided by the facing handles, the hook block or the rope! The helper could be crushed between the turntable and the hook block.



A mounting lever or the pump rod of the tipping device for the driver's cab can be used to guide or turn the hook block.

- Push the retaining rod through the bores (4) in the holder and the grip plates in the hook block. Secure the rods into place using the retaining pins.





Possible reeving methods on the two-stage swing-away lattice extension (additional equipment) and boom extension (additional equipment)
▣▣▣▣ Possible reeving methods on the lattice extension, p. 11 - 46.

10.5.6

Anemometer (additional equipment)

For operation with main boom you should install the anemometer (additional equipment) on the holder on the main boom head.

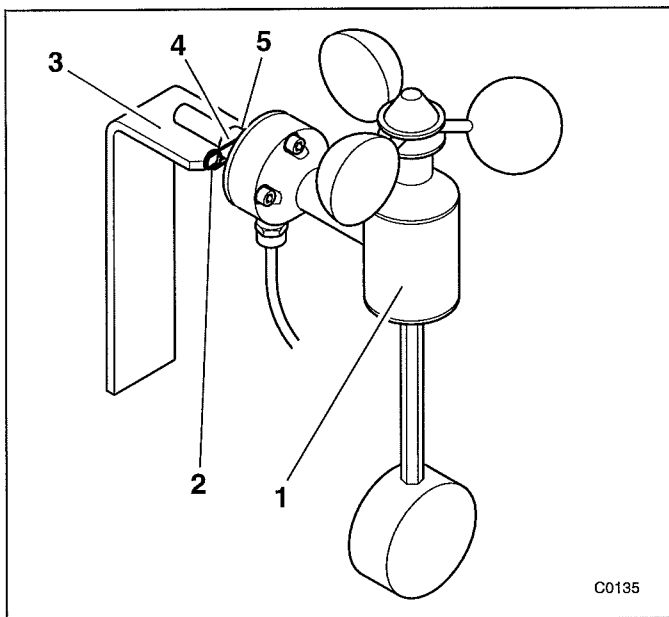

- Fit the anemometer (1) into the holder (3) on the main boom head.
- Turn the anemometer so that the bores (4) and (5) in the anemometer and holder are aligned with each other.
- Insert the retaining pin (2) into the bore!
- Check the mobility of the anemometer. The anemometer must return to a vertical position after being swung outwards.
- Connect the plug of the connecting cable to the socket of the terminal box on the head of the main boom.



Lay the cable in such a way that it cannot be damaged or crushed.



You must remove the anemometer before unrigging the main boom. The retaining pin remains in the holder. If the anemometer is not to be plugged into the telescopic swing-away lattice extension, it must be stored away safely.

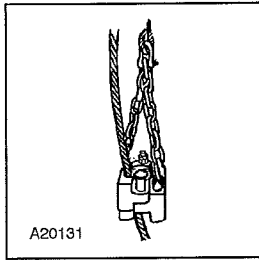

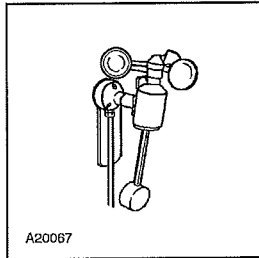

7. Remove the lifting limit switch weight.

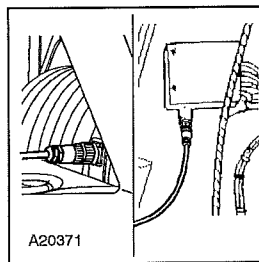

8. If necessary remove the anemometer;  *Anemometer*, p. 11 - 37.



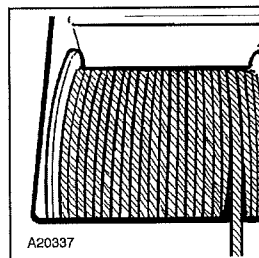

9. If necessary move the swing-away lattice extension into the 0° position;  *Moving lattice extension into the 0° position*, p. 11 - 44.

10. Detach electrical connections to the main boom;  *Electical connections between 10 m section and main boom*, p. 11 - 36.

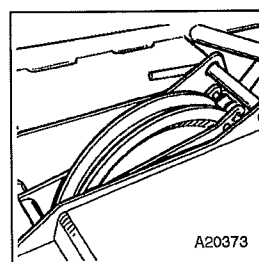

11. Wind in hoist rope.



12. Move deflection sheave into transport position;  *Moving deflection sheave into transport position*, p. 11 - 38.

13. Attach the guide rope to the 10 m section of the lattice extension.



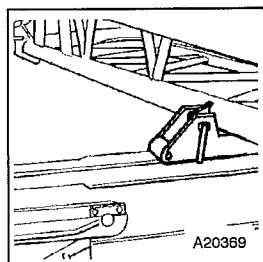

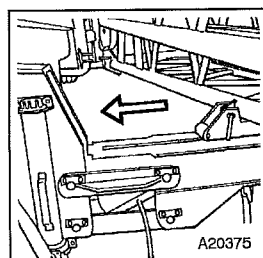

21. Connect the 10 m section with the bearing point of the slide;  Pin between bearing block and 10 m section, p. 11 - 24.

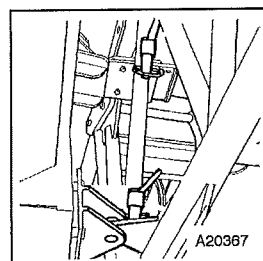

22. Push 10 m section and 8 m section onto the main boom;  Slide of the bearing block, p. 11 - 33.



23. Connect 10 m section and main boom with two pins;  Pins in swivel bearing between 10 m section and main boom, p. 11 - 25.

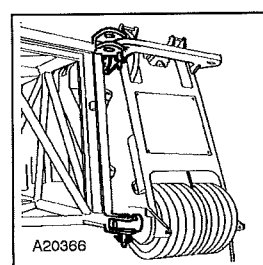

24. Remove swivel pins between 10 m section and main boom head;  Swivel pins between main boom head and foot of the 10 m section, p. 11 - 28.

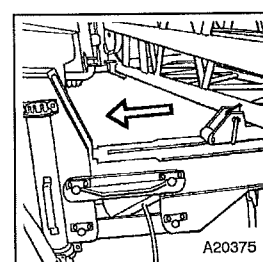

25. Swing two-stage swing-away lattice extension on the slide fully onto the main boom;  Slide of the bearing block, p. 11 - 33.

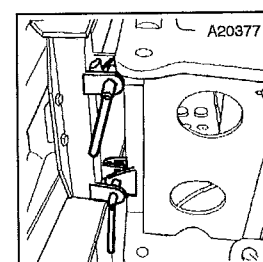

27. Lock the 8 m section to the main boom;  Pins between 8 m section and main boom, p. 11 - 24.



To unrig the swing-away lattice extension or the two-stage swing-away lattice extension:

The swing-away lattice extension or the two-stage swing-away lattice extension must be folded back and the pins inserted and secured between the 10 m section and the main boom;  *Pins in swivel bearing between 10 m section and main boom, p. 11 - 25.*

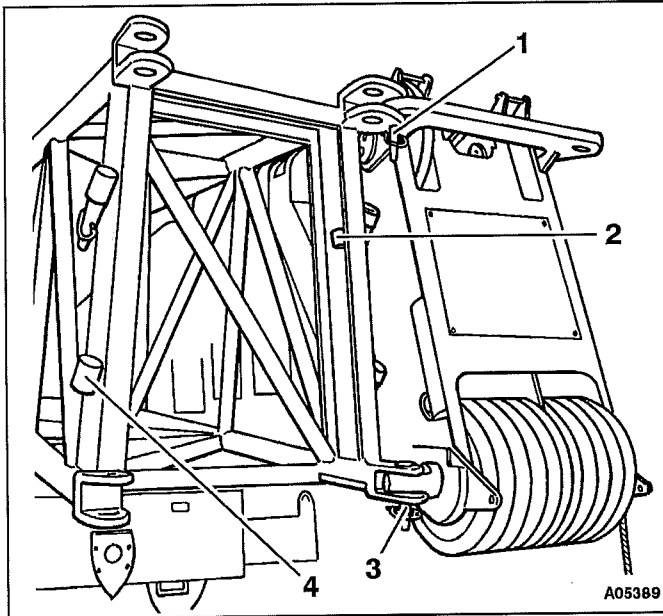

- Remove the pin (1) from the bearing point and insert it in the holder (2).
- Remove the pin (3) from the bearing point and insert it in the holder (4).
- Secure the pins using retaining pins.

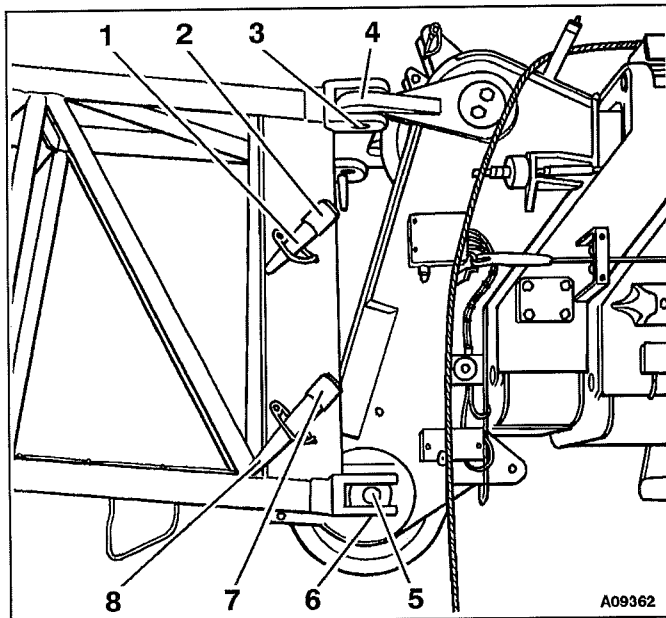

Connecting pins between 10 m section and main boom

To rig the swing-away lattice extension or the two-stage swing-away lattice extension:

After swinging the 10 m section in front of the main boom head the bores (3) and (6) at the foot of the 10 m section must align with the bearing points (4) and (5) at the main boom head.

- Take out pins (1) and (8) from holders (2) and (7).
- Insert the upper pin (1) first then the lower pin (8) in the bearing points between the 10 m section and the main boom head. Secure the pins using retaining pins.



The longer pin (8) is to be inserted in the lower bearing point.



Reeving the hoist rope

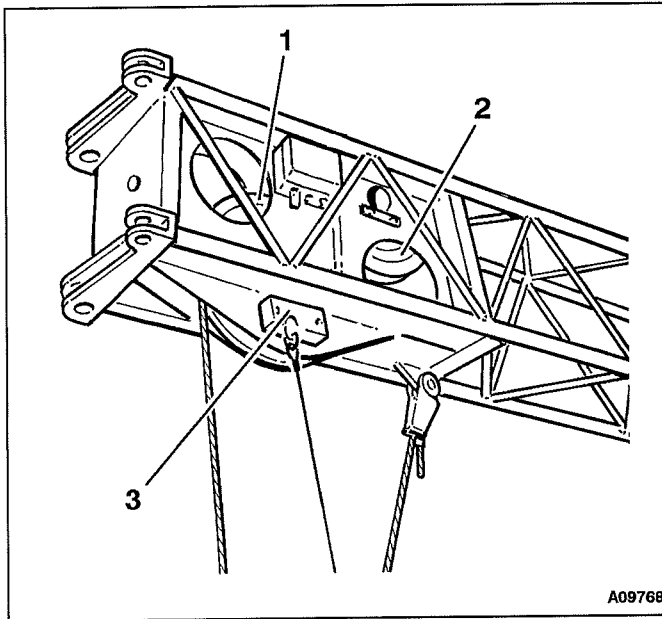

Reeving hoist rope on the swing-away lattice extension

- Lay the hoist rope over both head sheaves (1) and (2).
- Attach the boom hook or the hook block. The hoist rope can be reeved once or twice with the 10 m swing-away lattice extension; **▶** *Possible reeving methods on the two-stage swing-away lattice extension, p. 11 - 46.*
- Attach a hoist limit switch weight with a shackle to the lifting limit switch (3) of the swing-away lattice extension; **▶** *Lifting limit switch, p. 11 - 40.*

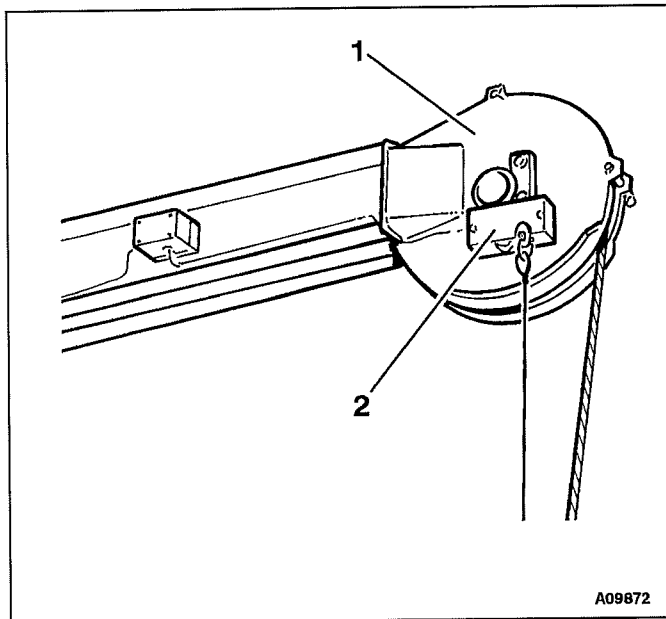

Reeving hoist rope on the two-stage swing-away lattice extension

- Lay the hoist rope over the head sheave (1).
- Attach the hook tackle. With the 18 m two-stage swing-away lattice extension the hoist rope can only be reeved with one fall; **▶** *Possible reeving methods on the two-stage swing-away lattice extension, p. 11 - 46.*
- Attach a hoist limit switch weight with a shackle to the lifting limit switch (2) of the two-stage swing-away lattice extension; **▶** *Lifting limit switch, p. 11 - 40.*



Checking the transport condition

The two-stage swing-away lattice extension must be in the following condition when transporting it on the basic section:

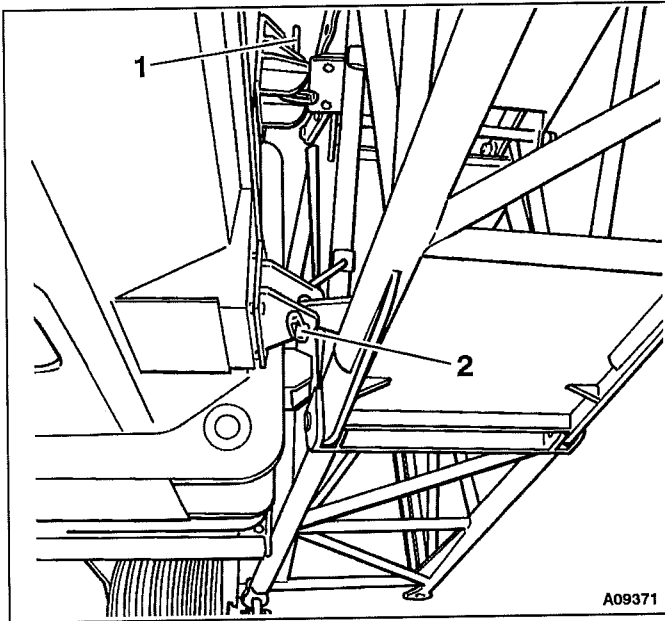

Pins (1) and (2) must be inserted between the non-telescoping section of the main boom and the 10 m section and secured with retaining pins.

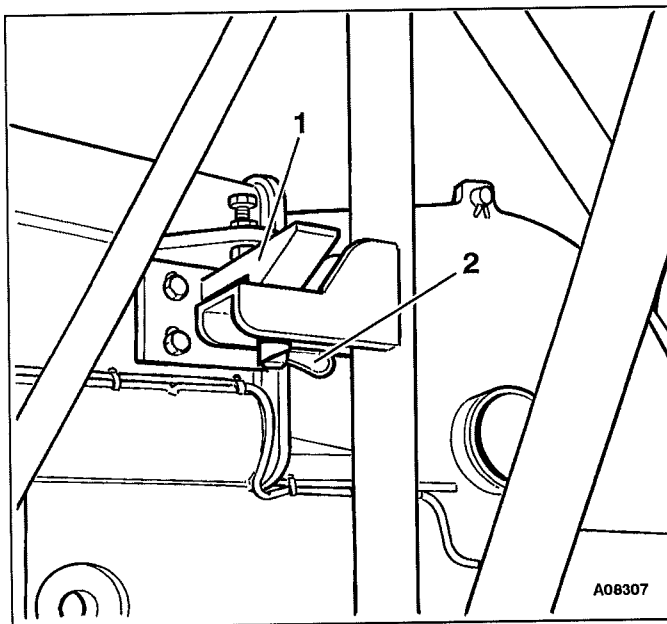



The 8 m section and the 10 m section are connected together with the snap lock (2). The hand lever (1) points to the right.

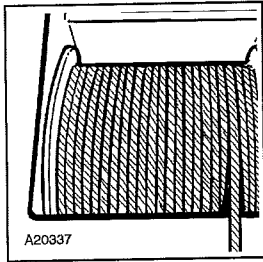



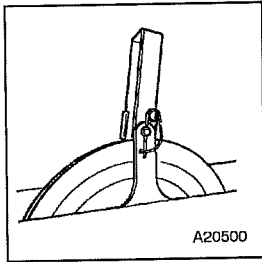

6. Wind in hoist rope.



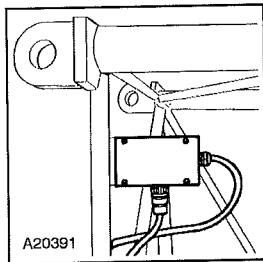

7. Exchange guide holder for guide sheave;  p. 11 - 68.

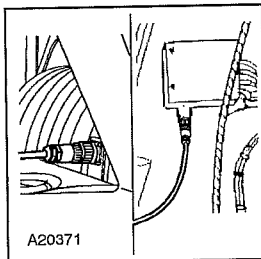

8. Disengage the lifting limit switch locking system on the 10 m section and on the main boom.

9. Detach the electrical connection between intermediate sections;
 *Detaching electrical connection*, p. 11 - 66.



10. Detach electrical connections between main boom and intermediate section;  *Electrical connection between 10 m section and main boom*, p. 11 - 36.

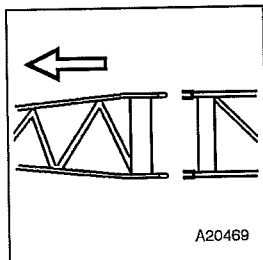

11. Release 8 m section from intermediate section II and lay on the ground.

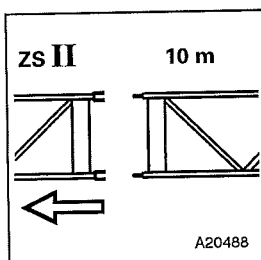

12. Release intermediate section II from 10 m section and place on the accompanying vehicle.



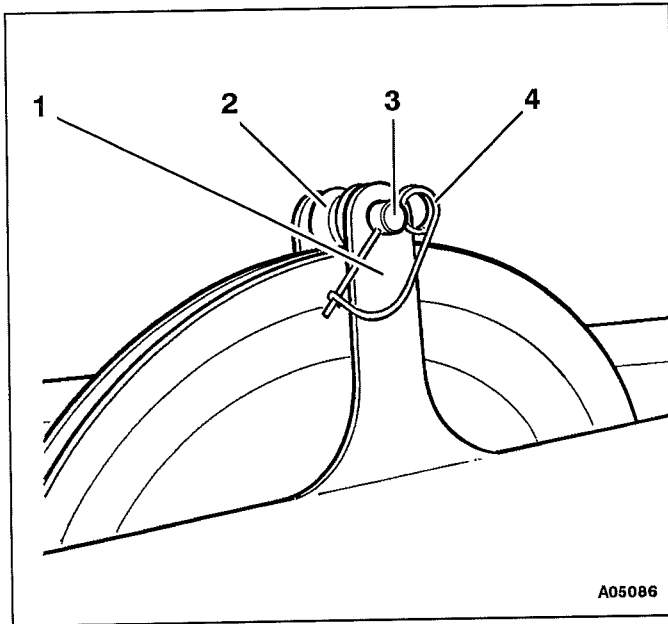

- Pull the retaining pin (4) out of the pin (3) and remove it, together with the sheave (2), from the holder (1) at the head sheave of the 10 m section.

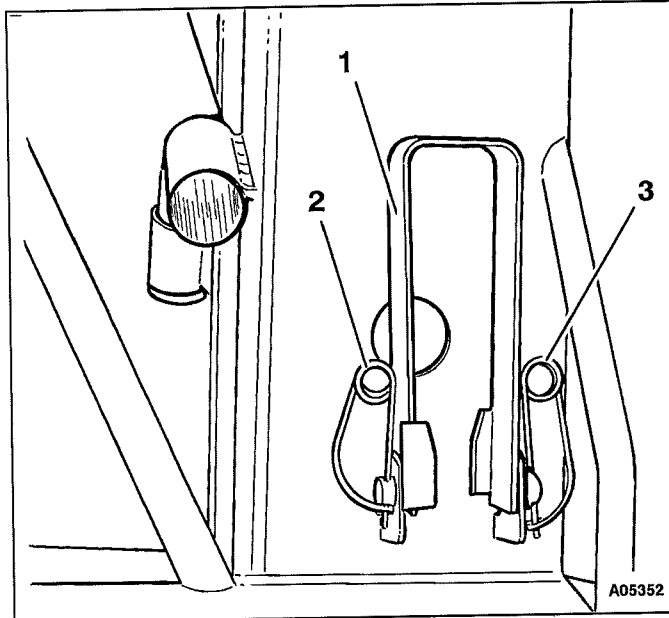

- Remove both retaining pins (2) and (3) on intermediate section II from the guide holder (1) and remove it from the holder.

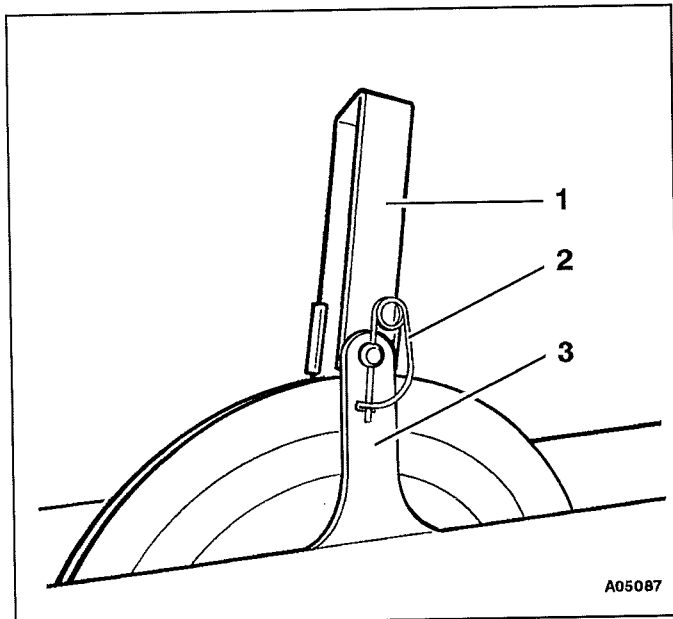

- Place the guide holder (1) onto the holder (3) on the head sheave.
- Secure both the left and right holders with a retaining pin (2).
- Attach the guide sheave with the pin in the holder on the intermediate section II and secure it with a retaining pin.

27.01.1997



11.3.3

Preconditions

Before lowering or extending the boom, the following conditions must be met:

- The truck crane is supported on outriggers;  *Outrigger*, p. 10 - 15.
- The superstructure is turned to a random position according to the space available.
- The main boom is completely retracted.
- The main boom is approximately horizontal.

Use the sliding ladder provided with your truck crane to attach the auxiliary single-sheave boom top.

11.3.4

Moving the additional single-sheave boom top into working position

Swing the auxiliary single-sheave boom top in front of the main boom

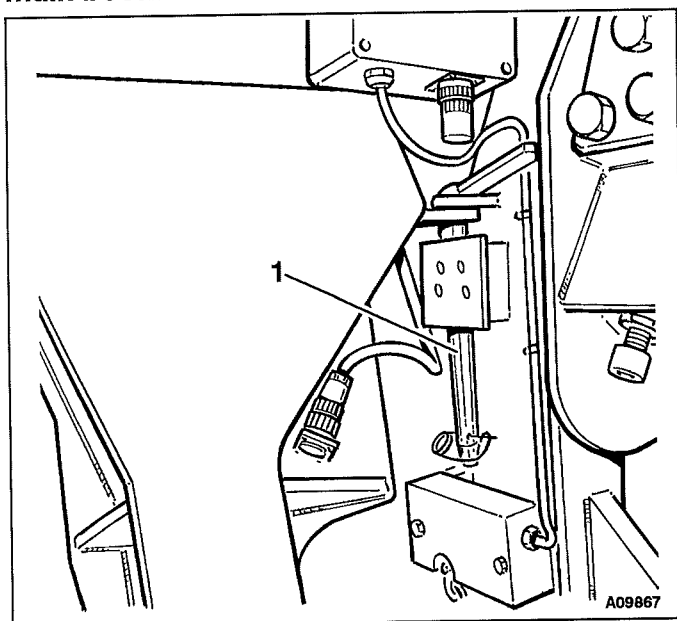

- Remove the securing pin (1) from the bearing point.



11.5

Driving with rigged crane and lattice extension installed

This section describes moving the truck crane with an installed counterweight and lattice extension.



If the truck crane is equipped with separate steering, Deutsche GROVE GmbH recommends switching to "Separate steering" when driving on the construction site at low speeds or when steering at a standstill on the construction site.



Risk of accidents!

It is forbidden to move the truck crane with a suspended load. Put the load down before you move the truck crane. Secure the hook block so that it cannot swing.

11.5.1

Driving route

The route must be a flat, even surface. The level adjustment system cannot compensate for uneven surfaces. If the surface pressure of the tyres exceeds the permissible load on the ground, the surface pressure must be increased using packing made of durable material (e.g. wooden planks).



Be careful not to damage the tyres!

Release the air from the tyres. Do not reduce the tyre pressure!

11.5.2

Position of the boom

The truck crane may only be moved if certain conditions are met. The boom may have to be moved to a certain position, depending on the counterweight mounted.



Danger of overturning!

Always move the boom to the prescribed position before you move the rigged truck crane. The permitted load on the axle lines will be exceeded if the boom is in a position which deviates from the prescribed position.



12.1

Rigging the outrigger beams

The front and rear outrigger beams can be removed; the removal procedure is the same for both outrigger beams.

The hydraulic lines can be detached with quick couplings. Matching coupling halves are marked with the same colour.

Space required and equipment

A list of space requirements and equipment for the assembly and removal of the outrigger beams is given below.

Space required for installation (excluding access roads or shunting area): when installing and removing the outrigger beams approx. 300 m² with approx. 17 m width (minimum width 9.5 m)



These specifications are dependent on the size of the auxiliary cranes and the separate vehicles. They can vary for each individual job.

Auxiliary crane:	an auxiliary crane. For truck crane measurements and weights see section ▣► <i>Dimensions and weights</i> , p. 15 - 13.
Lifting gear:	suitable chains or ropes with sufficient load bearing capacity.
Tool:	supplied toolbox.
Separate vehicles:	one or more separate vehicles are required, depending on the load bearing capacity and size of the loading area.



Danger of overturning!

If the truck crane is not on outriggers, it overturns when the superstructure is turned.

Do not use the truck crane to raise the outrigger beams! The truck crane may only be turned when all four outrigger beams are installed and the truck crane is supported on them.

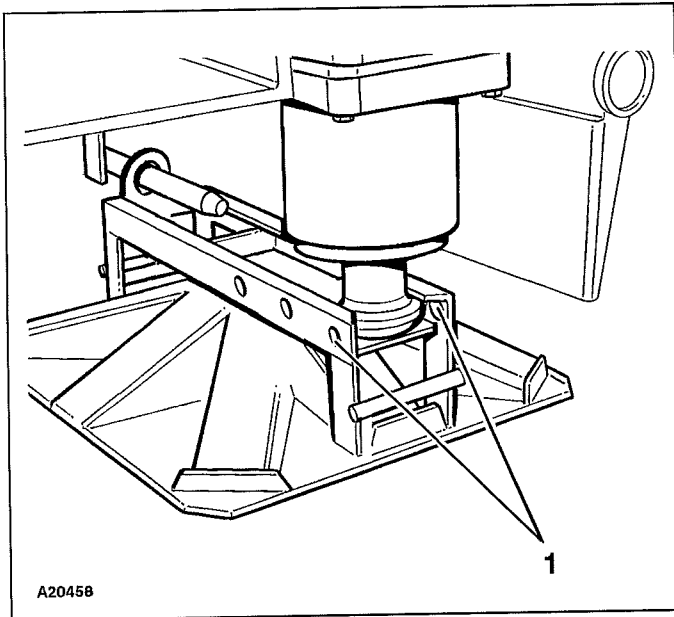

- Pull the outrigger pad outward as far as it will go, so that the threaded bores (1) are freely accessible.
- Fasten a screw in both of the bores in order to prevent the outrigger pad from sliding out.



Accidents may occur due to the outrigger pad falling down!

It is essential to secure the outrigger pad with two screws. Otherwise, when rigging for transport, the unsecured outrigger pad can slide out of the guide mechanism and fall down.

Lift the main boom onto the superstructure



Risk of hands and arms being crushed!

If the main boom is not bolted to the bottom axle, it can swing and crush arms and hands at the turntable.

Do not connect any hydraulic hoses and do not intervene in the area between the main boom and the superstructure until the bottom axle has been bolted up.

- Lift the main boom over the superstructure with the auxiliary crane.
- Wait until the main boom no longer swings back and forth.
- Lower the main boom with the auxiliary crane until the bores at the foot section of the main boom align with the bolts in the superstructure.
- Hold the main boom in this position on the superstructure with the auxiliary crane.

Before setting down the main boom onto the boom support and releasing the lifting gear, the foot section of the main boom must be bolted to the superstructure;  *Insert bolt for bottom axle of main boom, p. 12 - 30.*

Establishing the hydraulic connection

- Remove the protective caps on the hydraulic connections.
- Screw the couplings of the hose pipes onto the quick-release connections.

Matching half couplings and quick-release closures are marked with the same colour.

12.2.8

Main boom electric system

Two sockets for the electrical control system and the electric power supply for the main boom are located on the lefthand side of the main boom.



Risk of malfunctions due to short circuits!

Lay the electrical cables in such a manner that they do not rub against anything and the cables cannot be crushed.

Disconnecting the electrical connection

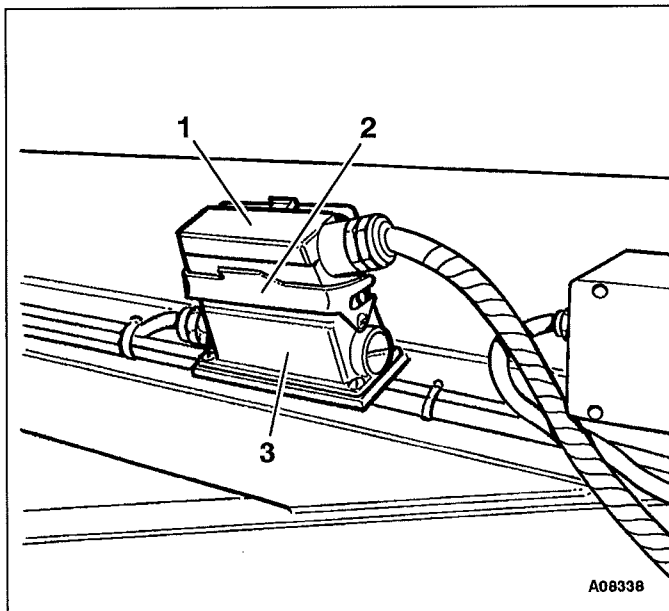

- Release the safety bracket (2).
- Remove the plug (1) from the socket (3) and protect from dirt.



13.3

Towing the truck crane

Observe the following when towing the truck crane:

- The truck crane may only be towed with a tow-rod. Attach the tow-rod on the tow-rod coupling on the front bumper of the truck crane and the towbar coupling of the towing vehicle.
- Observe the statutory regulations concerning the overall length of the towing and towed vehicle, including the tow-rod.
- If the vehicle engine, the steering and the service brake still work, you may tow the truck crane with a truck.
- If the vehicle engine, the steering and the service brake no longer function properly, the truck crane must be towed with a special breakdown truck.
- Maximum towing speed is 25 km/h.



Towing with running vehicle engine

If the compressed-air supply is damaged, you must connect the filler connection of the truck crane to the *Supply* coupling head of the towing vehicle;  *Compressed-air supply for vehicle engine breakdown* in this section, p. 13 - 9.



Accidents may occur if the brakes fail!

If the service brake system of the truck crane is damaged, the crane can only be braked by the towing vehicle. You should therefore use extreme caution when towing.

- Run at the vehicle engine at idling speed when towing away.
- Switch the automatic gearbox into neutral position;  *Driving ranges of the automatic gearbox*, p. 6 - 19.
- Switch the transfer case into neutral position;  *Gear box* in this section, p. 13 - 10.



13.5

Driver's cab tipping device

This section explains how to tilt the driver's cab for vehicle engine maintenance work. You must be able to start the superstructure engine in order to lift the main boom and the hook block.

Please note the following before tipping the driver's cab:

- All loose objects must be removed from the driver's cab!
- The main boom must be raised approx. 1.5 m in order to prevent the driver's cab from touching the main boom when tipping!
- Ensure that the hook block is at a sufficient distance from the wind-screen when tipping!
- The front grille must be removed before tipping the driver's cab!

The hand pump for tipping the driver's cab is located in front of the steps under the right-hand door of the driver's cab. The locking device for the driver's cab opens automatically when tipping.

Tipping the driver's cab

- Remove the front grille;  *Checking oil level in the vehicle engine*, p. 5 - 5.

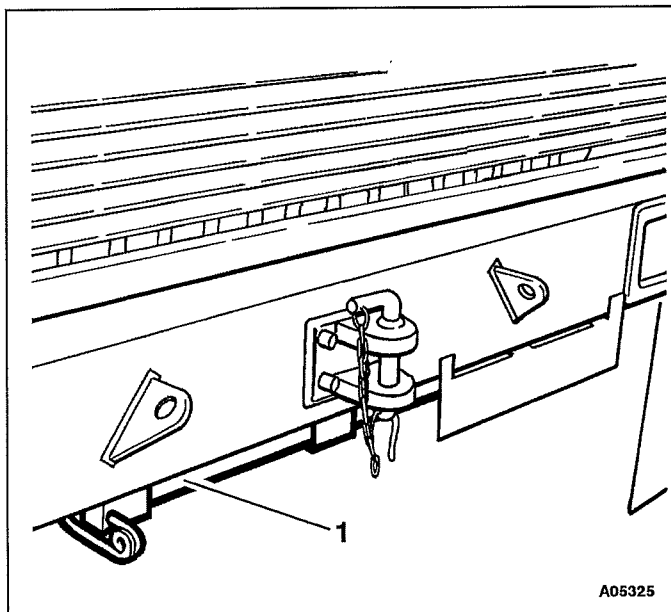

- Remove the pump lever (1) from the holder.



13.8 Malfunction tables

13.8.1 Vehicle engine malfunctions











Malfunction	Cause	Action
Engine does not start (starter motor does not turn over)	Battery master switch not turned on	Switch on battery master switch,  section 5.1.2.
	Ignition not switched on	Switch on ignition,  section 5.1.3.
	Automatic gearbox not in the neutral position	Move the automatic gearbox to position N ,  section 5.1.3.
	Parking brake not engaged	Engage the parking brake,  section 5.1.3.
	Fuse F1/3 UW blown	Check fuse and replace if necessary,  section 13.7.2.
Engine does not start (starter motor turns over)	Batteries flat	Charge batteries,  refer also to Maintenance Manual.
	Fuel tank empty	<ol style="list-style-type: none"> 1. Fill fuel tank,  section 6.1.2 2. Bleed fuel system,  see Mercedes-Benz operating manual.
Flame start system indicator lamp does not illuminate after ignition is switched on with cold engine	Fuse F6/4 UW blown	Check fuse and replace if necessary,  section 13.7.2.
Engine air filter warning lamp is on	Air filter blocked	Replace dry air filter (see Maintenance Manual).
Engine coolant level warning lamp is on	Coolant level too low	Top up coolant,  section 5.1.2.

Table of Contents

14	Malfunctions on the superstructure	14 - 3
14.1	Emergency stop device on superstructure	14 - 3
14.2	Troubleshooting for malfunctions that occur during crane operation	14 - 5
14.3	Electrical system	14 - 7
14.3.1	Plug-in modules and consoles	14 - 7
14.3.2	Fuses	14 - 8
14.3.3	SLI fuses	14 - 10
14.4	Malfunction tables	14 - 13
14.4.1	Crane engine malfunctions	14 - 13
14.4.2	Main hoist malfunctions	14 - 14
14.4.3	Auxiliary hoist malfunctions	14 - 15
14.4.4	Derricking gear malfunctions	14 - 16
14.4.5	Telescoping gear malfunctions	14 - 17
14.4.6	Slewing gear malfunctions	14 - 18
14.4.7	Counterweight lifting gear malfunctions	14 - 18
14.4.8	Hydraulic oil cooler malfunctions	14 - 19
14.4.9	Unlocking telescope section I mechanically	14 - 20
14.4.10	Malfunctions on the SLI	14 - 23

Position of the data transmitters

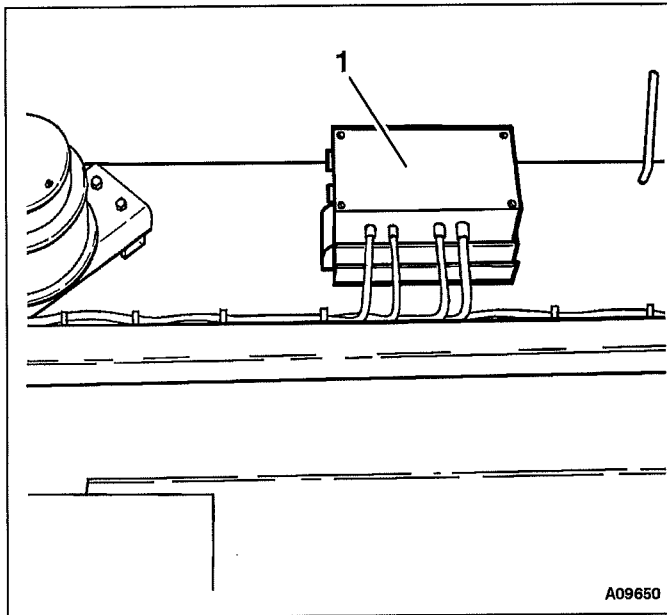

The data transmitters for

- main boom angle
- length of telescope section I
- length of telescope section II to III

are located in the terminal box (1) on the left-hand side of the basic section of the boom.

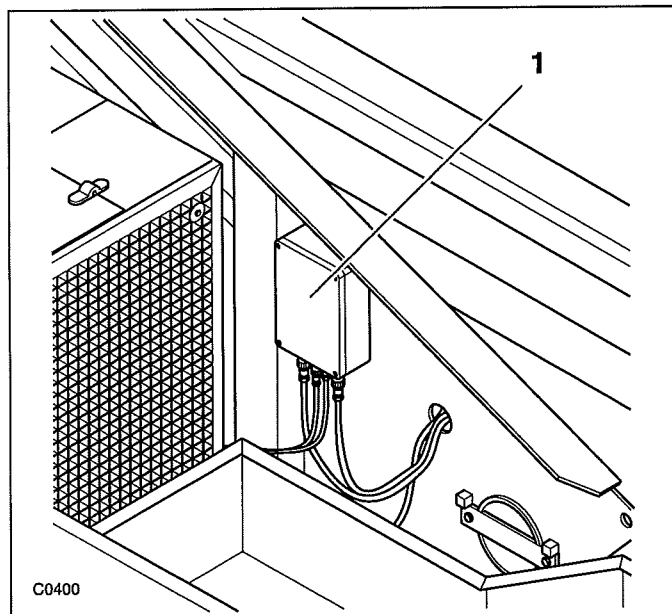

The data transmitters for

- hydraulic pressure of the derricking cylinder ring area
- hydraulic pressure of the derricking cylinder piston surface

are located in the terminal box (1) on the right-hand side of the turntable above the storage box.



If the above prerequisites are not met, the lock must be released with the main boom raised using a second crane with a working cage.



Risk of accidents!

You should only use a working cage designed for personnel transport for this work.

Releasing the telescope lock mechanically

The two hydraulic cylinders for the telescope locking system are on the right and left of the collar of the basic section of the boom.

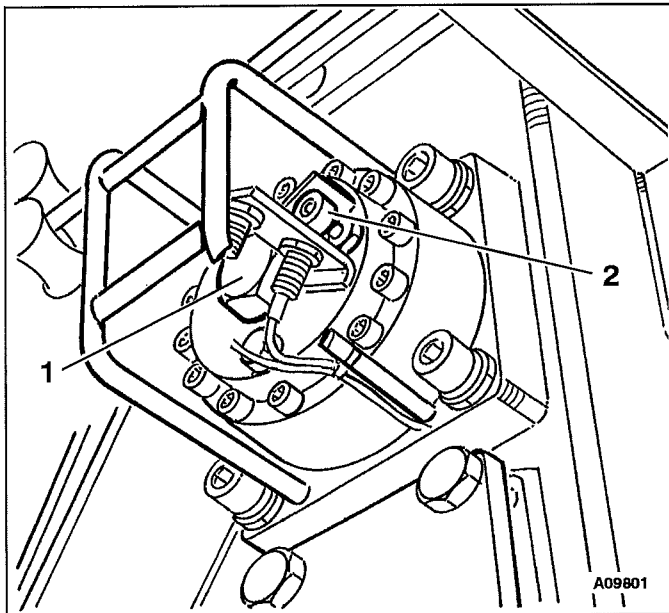

- Release both locks.
- Reduce the load on the locking pins by extending and retracting telescope section I.
- Release the lock by turning screw (1) to the left (spanner size 32, required torque approx. 180 Nm).
- Unscrew bolt (1) at least 40 mm. The indicator pin (2) also comes out as you do so.
- Retract telescope section I completely.



Risk of accidents!

No loads can be raised when telescope section I is unlocked. This could damage the main boom.



15.1.2

Superstructure

Turntable

The crane engine, pumps, the tank of the crane's hydraulic system, the main boom, hoists, slewing gear, derricking cylinder, crane operator's cab and counterweights are located on the turntable.

Crane operator's cab

All operating and control instruments required for crane operation are installed in the crane operator's cab on the front left-hand side of the turntable.

The cab is surrounded with safety glass and the sliding door has a sliding window. The roof window, made of tinted toughened glass, may be adjusted to ventilate the cab.

The cab is heated via a heat exchanger using the engine coolant. The coolant used to preheat the engine and to heat the cabs can be heated with an additional water heating system.

Crane engine and hydraulic system

The crane engine, a water-cooled Mercedes Benz diesel engine, drives two axial-piston variable displacement pumps and the triple gear fixed displacement pump of the crane's hydraulic system via a pump distribution gearbox.

The variable displacement pumps are adjusted via a critical load control system. The critical load control system can be switched off.

The tank of the crane's hydraulic system is located on the turntable behind the crane operator's cab. An oil filter is fitted in the return line. A stop cock is situated on the tank of the crane's hydraulic system in the suction line to the hydraulic pumps. This facilitates repairs without draining the oil.

Main boom

The main boom consists of the basic section and 4 telescope sections and is rigged with two pin extractors.

The main boom can be removed for on-road driving.

For two-hook operation, a single-sheave auxiliary single-sheave boom top (additional equipment) can be installed in front of the main boom. During transport, the auxiliary single-sheave boom top is fastened to the head of the main boom.

The main boom may be extended using the tiltable two-stage swing-away lattice extension (additional equipment). The lattice extension is fastened to the non-telescoping boom section of the main boom for transportation purposes.

The two-stage swing-away lattice extension with the intermediate sections can be converted into a boom extension as additional equipment.



Air pressure:

Tyres	Air pressure (bar)
14.00 R 25	10.0
16.00 R 25	9.0
17.50 R 25	7.0
20.50 R 25	7.0

Outriggers

Design: 4-point telescoping outrigger system, doubly extendable
Control: Can be controlled individually from either side of the carrier

Outrigger span: **A** = 8.575 m x 8.20 m
B = 8.575 m x 5.42 m
C = 8.575 m x 8.20 m / 5.42 m
(5.42 m span width at rear)

Size of outrigger pads: 600 x 700 mm

Outrigger pad surface area: 4200 cm²

Max. outrigger pressure: 810 kN (≅ 83 t) with span **A**
1069 kN (≅ 109 t) with span **B**

Outrigger cylinder stroke: 550 mm rear
450 mm front

Vehicle's electrical system

Alternator: 28 V/55 A

Batteries: 2 each 12 V/170 Ah

On-board voltage: 24 V

Tools

One tool kit in tool box,
four wheel chocks,
first-aid kit,
warning triangle,
warning lamp



16

Alphabetical index



You will find instructions for the use of this index on p. 1 - 12. To avoid making the index unnecessarily long and unclear, we have not included every single element from the instrument panel. These elements such as rocker switches, warning and indicator lamps as well as status displays are described and named in detail in the overviews of the chapter 4 *Description of the truck crane – vehicle section* and the chapter 7 *Description of the truck crane – crane section*. From there, you will be referred to more detailed descriptions of these elements.

A

Activating the ignition	
carrier	5 - 12
Additional heating system	4 - 38, 6 - 54
activating	6 - 54
deactivating	6 - 55
Adjusting the mirror	6 - 14
on the superstructure	9 - 9
Adjusting the seat	
in the crane cab	7 - 49
in the driver's cab	6 - 13
Adjusting the steering column in the driver's cab	6 - 14
All-wheel steering mode	6 - 47
Anemometer	
installing on the main boom	10 - 61
on the lattice extension	11 - 37
on the main boom	9 - 30
status display	7 - 46
Automatic gear box driving modes	6 - 22
Automatic gearbox	6 - 19
behaviour when upshifted	6 - 23
checking the oil level	5 - 6
diagnosis switch	6 - 21
Display and operating instruments in the driver's cab	4 - 26
driving modes	6 - 22
driving ranges	6 - 19
Operation	6 - 19
procedure in the event of malfunctions	13 - 36
Starting and stopping	6 - 22
Automatic gearbox diagnosis switch	6 - 21

CLICK HERE TO **DOWNLOAD** THE COMPLETE MANUAL

- Thank you very much for reading the preview of the manual.
- You can download the complete manual from: www.heydownloads.com by clicking the link below



- Please note: If there is no response to CLICKING the link, please download this PDF first and then click on it.

CLICK HERE TO **DOWNLOAD** THE COMPLETE MANUAL