

Operating Instructions

CE

Hydraulic Excavator

RH 90C No.

Bucyrus HEX GmbH



CLICK HERE TO **DOWNLOAD** THE COMPLETE MANUAL

- Thank you very much for reading the preview of the manual.
- You can download the complete manual from: www.heydownloads.com by clicking the link below



- Please note: If there is no response to CLICKING the link, please download this PDF first and then click on it.

CLICK HERE TO **DOWNLOAD** THE COMPLETE MANUAL

Main filter elements	117
Removal and installation	117
Checking and cleaning the main filter element.....	118
Safety filter element	119
Replacement	119
Air-intake lines	119
Dust collection	119
FUEL SYSTEM	
Fuel system - Safety instructions	120
Replacing the fuel filter.....	120
Venting the fuel system	121
Cleaning the fuel tanks.....	121
ELECTRICAL SYSTEM	
Electrical system - Safety instructions	123
Alternator - Instructions	123
Battery main switch / Main fuse	124
Battery	124
Checking the battery fluid level.....	124
Checking the battery charge	124
Removing and installing the battery	125
HYDRAULIC SYSTEM	
Hydraulic system - Safety instructions	126
Depressurizing the hydraulic system	126
Checking the hydraulic oil level / Topping up with oil	127
Changing the hydraulic oil return-flow	129
Bypass valves	130
Cleaning the filter screens	130
Replacing the bypass valves and the sealing rings	130
Breather filter	131
Replacing the filter elements	131
High-pressure filter for working hydraulics	131
Checking/cleaning the filter elements.....	132
Replacing the filter elements	132
High-pressure filter for the servo circuit	133
Checking/cleaning the filter elements.....	133
Replacing the filter elements	133
Changing the hydraulic oil	134
Drawing/draining off the hydraulic oil	134
Drawing off hydraulic oil	135
Cleaning the hydraulic oil reservoir	135
Filling in hydraulic oil	136
Venting the hydraulic system	137

Preface

These operating instructions are designed to familiarize the operator with the machine and its designated use.

The instruction manual contains important information on how to operate the machine safely, properly and with maximum efficiency. Observing these instructions helps to prevent hazardous situations, to reduce repair costs and downtimes and to increase the reliability and service life of the machine.

The instruction manual must be supplemented by the respective national rules and regulations for accident prevention and environmental protection.

The operating instructions must always be available in the operator's cab of the machine.

The operating instructions must be read and put into practice by any person in charge of carrying out work with or on the machine, such as

- **operation**, including setting-up, troubleshooting in the course of work, care, evacuation of production waste and disposal of fuels and consumables.
- **maintenance** (inspection, servicing, repair) and / or
- **transport**.

In addition to the operating instructions and the mandatory rules and regulations for accident prevention and environmental protection in the user's country and at the place where the machine is to be used, the generally recognized technical rules for safe and proper working must be observed.
[1]

The operating instructions are directed to the construction-machine specialist. They cannot provide basic know-how. This can be acquired, for example, in several days' instruction by a qualified O&K-Mining mechanic or by attending an O&K-Mining training course for operators or maintenance personnel.

The **O&K-Mining after-sales service** will be pleased to deal with any queries you may have after reading through the operating instructions.

All O&K-Mining operating manuals are issued in German and then translated. Even a good translation may give rise to questions which O&K-Mining will be pleased to answer.

The operating instructions are not working instructions for carrying out major **repairs**. Such work is willingly done for you by the **O&K-Mining after-sales service**.

The documentation relating to the machine is listed according to scope, quantity and language in the shipping note of the machine or in the covering letter if supplied separately. The operating instructions and spare-parts list are marked with the serial number of the machine.

On taking receipt of the consignment, please check that the documentation is complete and in the language requested by you. □

Warranty

2732604

O&K Mining GmbH's warranty is subject among other things to the maintenance works described in the Owner's Manual having been performed by the O&K Mining Service or by a workshop authorized in writing by O&K Mining to perform such work. □

[1] Complies with VDMA recommendation "Operating instructions"

PART 2 - OPERATION

	Operating manual	Target group
Part 1	INTRODUCTION FUNDAMENTAL SAFETY INSTRUCTIONS	Operating personnel + Inspection and servicing personnel + Repair personnel
Part 2	OPERATION	Operating personnel The operating personnel must have know-how relevant to the operation and the application of this or comparable machines.
Part 3	INSPECTION AND SERVICING	Inspection and servicing personnel The inspection and servicing personnel must have know-how relevant to the inspection and servicing of this or comparable machines.
Part 4	REPAIR WORK	Repair personnel The repair personnel must have know-how and experience relevant to the repair of this or comparable machines.
Part 5	ANNEX	Operating personnel + Inspection and servicing personnel + Repair personnel
Part 6	INDEX	Operating personnel + Inspection and servicing personnel + Repair personnel

□

Signs

The machine has been inspected and tested by authorized and independent testing institutes and bears the CE marking (Fig. 2) as a sign of conformity with EC-directives.

Warning and instruction signs



Observe the warning and instruction signs attached to the machine.
Keep the signs legible and clean.
Replace the signs immediately if they have become illegible.
New warning and instruction signs can be ordered from the O&K Spare-Parts Service. The ordering part numbers are set out in the spare-parts list of the machine.

Fig. 2 shows the location of warning and instruction signs on the machine.

Machine number

The identification plate with the machine number is attached to the front side of the A-frame (arrow, Fig. 3 resp. 4).

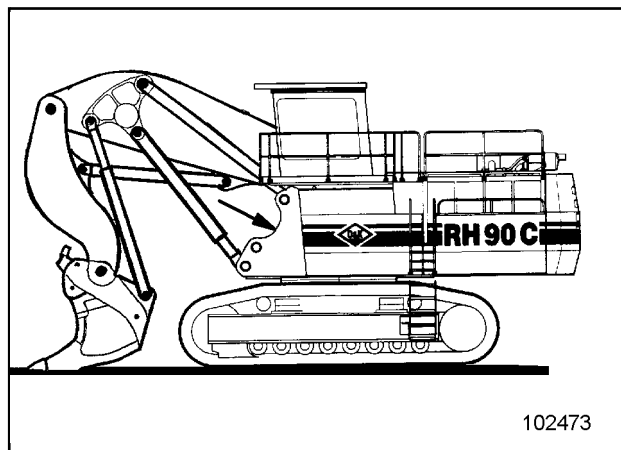

Fig. 3

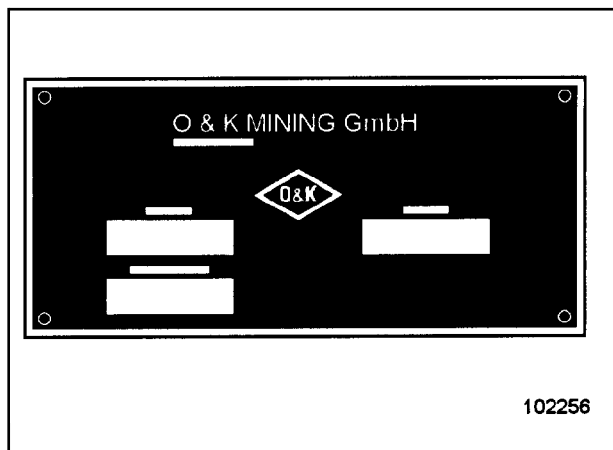

Fig. 4

Engine number

The identification plate (Fig. 5) with the engine number is attached to the engine.

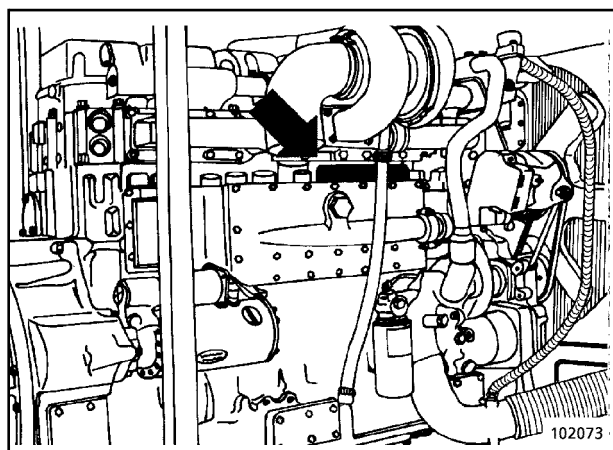

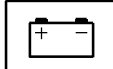



Fig. 5

Component numbers

Also the other larger units have identification plates indicating, among other things, their serial number.

On steel components, the O&K part number or the serial number may be stamped into the metal at a clearly visible place.

(Fig. 3)

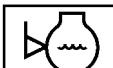
No.	Element	Function	Symbol
31	Warning lamp Alternator (engine 2 RH)	lights up when the alternator does not charge the batteries	
32	Warning lamp Engine oil pressure (engine 2 RH)	lights up when the engine oil pressure is too low	
33	Warning lamp Idle Timer (engine 2 RH)	lit up during the full after-run period of the engine (5 minutes)	
34	Warning lamp Engine temperature (engine 2 RH)	lights up when the engine temperature is too high	
35	Warning lamp cooling-water level (engine 2 RH)	lights up when the cooling-water level is too low	
36	Warning lamp	n.c.	

(Fig. 8)

No.	Element	Function	Symbol
82	Pedal Travelling, track chain left	track chain	
83	Pedal Travelling, track chain right	track chain	
85	Pedal Bucket shell (only with loading bucket equipment)	open/close bucket shell	
86	Key Servo control	servo control system ON/OFF	
87	Control lever	shovel/bucket stick up/down slewing and braking of superstructure	
88	Control lever	boom up/down; back-tipping of shovel/bucket	
91	Control lever Accelerator	Speed regulation for both engines	
92	Cigarette lighter		
93	Radio (Option)		
98	Clock		

□

Air conditioner (optional)

Select the desired temperature with the knob (2, Fig. 4) on the thermostat (1).

The temperature selected can be read on a scale.

The air is blown into the cab through nozzles (2, Fig. 5).

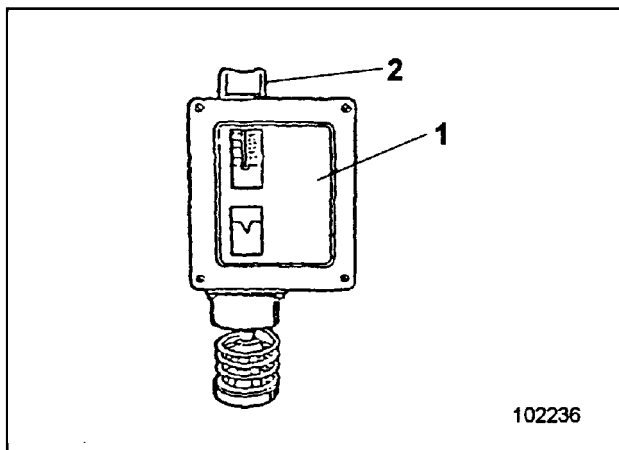

Fig. 4

Ventilation

Turn rotary switch (70, Fig. 6) to position 1 or 2.

- Position 1 - high amount of air (cold air)
- Position 2 - low amount of air (cold air)

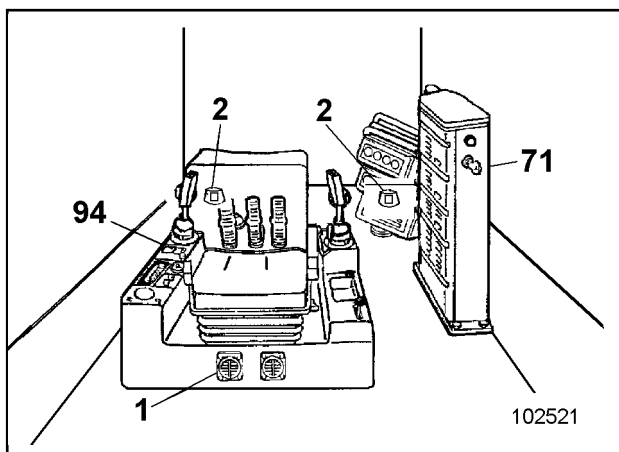

Fig. 5

Heating

Temperature control with thermostat (1, Fig. 4)

Turn rotary switch (70, Fig. 6) to position 3 or 4.

- Position 3 - high amount of air (cold or warm)
- Position 4 - low amount of air (cold or warm)

Monitoring lamp (5 or 6) lights up.

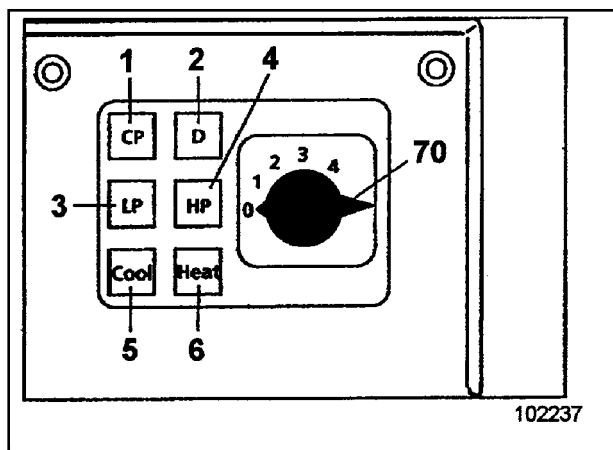

Fig. 6

Monitoring lamp (6) lights up when warm air is blown into the cab.

Monitoring lamp (5) lights up when cold air is blown into the cab.

To improve the temperature control, keep sliding windows closed.



At low temperatures, bring the engines down to moderate speed, then activate all hydraulic functions for about 10 minutes (bring to service temperature). For further instructions, see section "Lubricants".

If the BCS indicates problems with the cooling liquid temperature, engine oil pressure, cooling liquid level, alternator or hydraulic oil filter (with hydraulic oil at service temperature): lower the working equipment and shut off the engines.



Parts of the attachment may damage the machine if they are moved into extreme positions (as shown in fig. 1, for instance).

Work carefully, avoiding extreme positions of this kind.

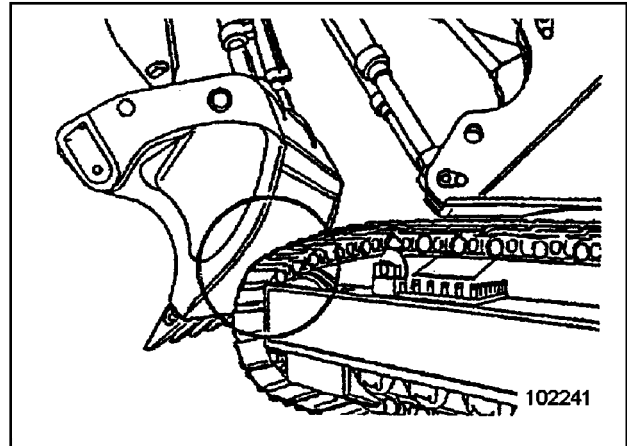

Fig. 1

□

PART 3 - INSPECTION AND SERVICING

	Operating manual	Target group
Part 1	INTRODUCTION FUNDAMENTAL SAFETY INSTRUCTIONS	Operating personnel + Inspection and servicing personnel + Repair personnel
Part 2	OPERATION	Operating personnel The operating personnel must have know-how relevant to the operation and the application of this or comparable machines.
Part 3	INSPECTION AND SERVICING	Inspection and servicing personnel The inspection and servicing personnel must have know-how relevant to the inspection and servicing of this or comparable machines.
Part 4	REPAIR WORK	Repair personnel The repair personnel must have know-how and experience relevant to the repair of this or comparable machines.
Part 5	ANNEX	Operating personnel + Inspection and servicing personnel + Repair personnel
Part 6	INDEX	Operating personnel + Inspection and servicing personnel + Repair personnel

□

Plan V - Once prior to initial commissioning

Location	Servicing work	Quantity/ No.
Engine Engine oil reservoir (optional)	Check oil level Check oil level	2 2
Cooling system	Check cooling liquid level	1
Electrical system Battery Lighting	Check charge condition Check operation	2
Monitoring, warning and control elements BCS	Check function of working and travelling movement Check function of indicators Check function of monitor	1
Hydraulic system Hydraulic oil reservoir Hydraulic cylinders	Check operation Check operating pressure ¹⁾ Check oil level Bleed systems	1
Pump transfer gearbox	Check oil level	2
Slewing gearbox Expansion reservoir	Check oil level	2
Travel gearbox	Check oil level	2
Slewing ring Internal gearing	Check grease filling	1
Undercarriage Track roller Support roller Track Idler	Check for leaks and free movement Check for leaks and free movement Check tension Check for leaks	2 x 8 2 x 2 2 2
Central lubricating system Grease container	Check filling level	1
Service station (tanklift)	Check operation	1

1) Carried out by the O&K-Mining After-Sales-Service.

CLICK HERE TO **DOWNLOAD** THE COMPLETE MANUAL

- Thank you very much for reading the preview of the manual.
- You can download the complete manual from: www.heydownloads.com by clicking the link below



- Please note: If there is no response to CLICKING the link, please download this PDF first and then click on it.

CLICK HERE TO **DOWNLOAD** THE COMPLETE MANUAL





III. Oils for gearboxes (selection)

Ambient temperature		°F	-22	-4	+14	+32	+50	+68	+86	+104	+122
		°C	-30	-20	-10	0	+10	+20	+30	+40	+50
Specification											
API	MIL - L										
GL 5	2105 C	Multigrade Gear-Oil P/No.1 589 636									
GL 5 GL 4	2105 B 2105	GL 4 / GL 5 - 140									
		GL 4 / GL 5 - 90									
		GL 4 / GL 5 80 W									

8003091

COOLING SYSTEM

2731673



Read and observe: "Inspection and servicing - Safety instructions".

Secure the machine as described in the "Securing the machine" section.

Shut off the engines and allow to cool down.

Risk of scalding from hot cooling liquid.

Collect escaping cooling liquid and discard without polluting the environment.

Protect the skin from contact with cooling liquid.

Skin contact with cooling liquid is a potential health hazard.

Wear protective gloves and firm working clothing.

Temperature

The cooling liquid circuit is controlled by a thermostat. The max. admissible temperature is approx. 100°C. In case of higher temperatures, the BCS displays a warning on the screen (Fig. 1).

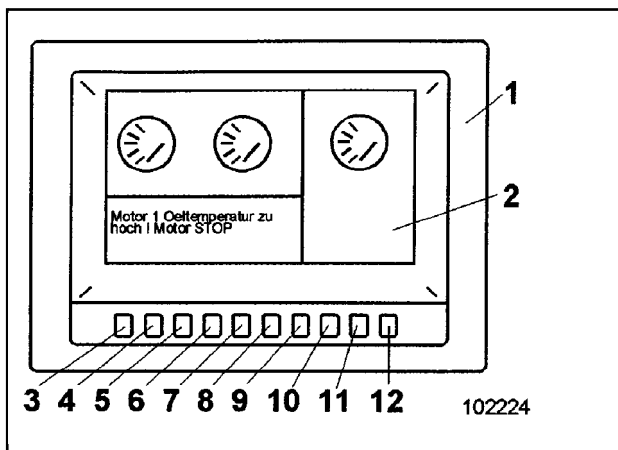

Fig. 1

Radiators

The radiators are located on the superstructure in front of the counterweight module.

Weekly checks:

- Check radiator fins for dirt and clean, if required..

Cooling-liquid level

An insufficient cooling-liquid level is displayed on the BCS screen (Fig. 1).

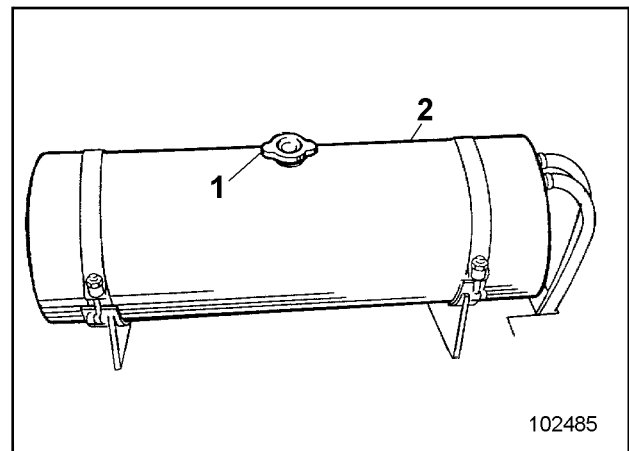

Fig. 2

The radiator caps (1, Fig. 2) are accessible from above.



Risk of scalding from hot cooling liquid. Open radiator cap cautiously.

- Turn radiator cap (1) back to the first notch.
- When the pressure has been released turn cap into the "open" position and remove.

The cooling-liquid level should reach up to the lower edge of the filler tube. Top up with cooling liquid, if required.

ELECTRICAL SYSTEM

2731676

Electrical system - Safety instructions



Read and observe the "Inspection and servicing - Safety instructions" chapter.

Risk of injury caused by battery acid and gases.

Wear goggles, working gloves and firm working clothing.

Carry out voltage and continuity checks only by means of a test lamp or a measuring instrument. Do not check by "touching ground" with a bare wire. The short-circuit thus produced damages the alternator and the electronic modules of the PMS.

The electrical circuit diagrams are annexed to the spare-parts list. Further information can be found in the O&K booklet "Working with circuit diagrams".

The electrical system switch-cabinet is located in the driver's cab below the control panel. The cabinet is described in the spare-parts list together with the designation of the electrical components.



Cut off the electrical system with the battery main switch before carrying out work on the electrical system. This prevents accidents, unauthorized starting of the engine and short-circuits.

Cables and cable lugs must not get in contact with other metal parts. Replace broken or damaged cables and the respective cable lugs.

Alternator - Instructions



Never disconnect cables from the alternator, regulator and the battery when the engine is running to avoid damage to the alternator and regulator.

Do not interchange the cables when connecting the battery (observe polarity).

Carry out voltage and continuity checks only by means of a test lamp or a measuring instrument. Do not check by "touching ground" with a bare wire. The short-circuit thus produced damages the alternator and the regulator.

High-pressure filter for the servo circuit

The excavator is equipped with two high-pressure filters (5, Fig. 17) for the servo circuit. Both filters are located in front of the hydraulic oil reservoir.

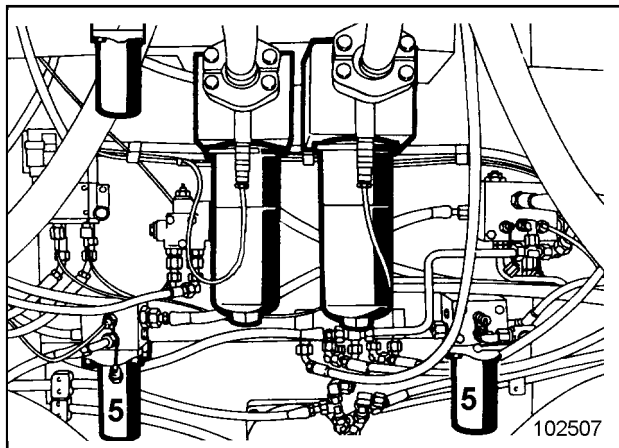

Fig. 18



Read and observe the "Inspection and servicing - Safety instructions" chapter.

Shut off the engines.

Risk of scalding caused by hot hydraulic oil.

The filter housings themselves may also be hot.

Avoid skin contact.

Skin contact with hydraulic oil may cause skin injury.

Wear protective gloves and firm working clothing.

Collect escaping hydraulic oil and discard without polluting the environment.

Checking/cleaning the filter elements

- Detach flange (4, Fig. 19).
- Remove filter housing and pour out used oil.
- Withdraw filter element (6) from filter housing (5).
- Clean filter housings and sealing faces at filter head with white spirit or paraffin oil.
- Insert new filter element into filter housing (5) and refit to filter head with a new, lightly oiled sealing ring (8).

Check the high-pressure filter for leaks after putting it into operation.

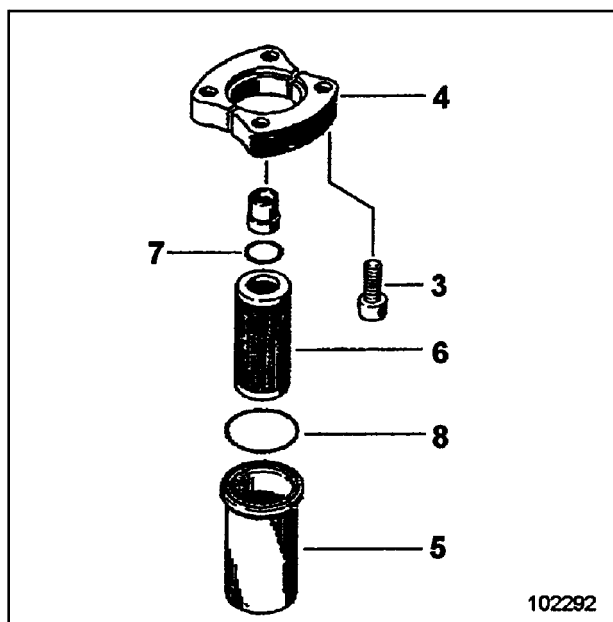

Fig. 19

Replacing the filter elements

- Detach the filter elements as described under "Checking the filter elements".
- Install new filter element (6, Fig. 19) and re-assemble with a new, lightly oiled sealing ring (7).

Check the high-pressure filter for leaks after putting it into operation.

Drain valve (7, Fig. 3) is accessible from the undercarriage.

- Remove hose. The drain valve closes automatically.
- Screw on protective cap.

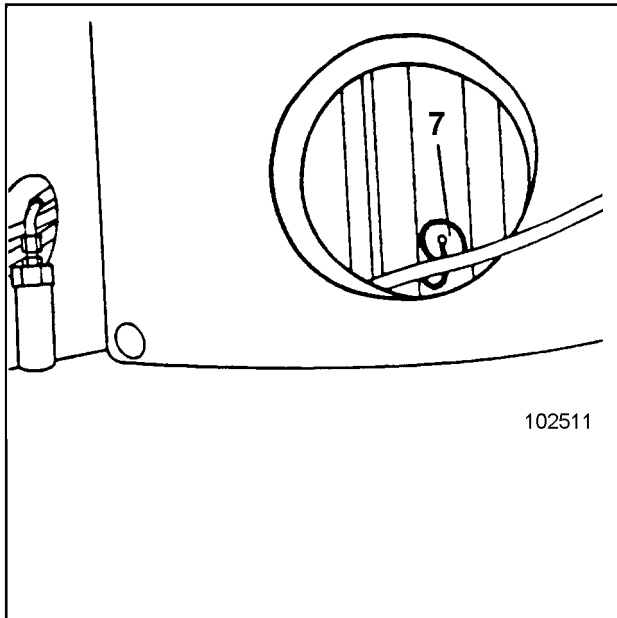

Fig. 3

Filling in new oil / Topping up

- Unscrew cap (8, Fig. 4) and fill in new oil through expansion tank (6). The expansion tank (6) must be filled with gearbox oil up to ca. 1/3.

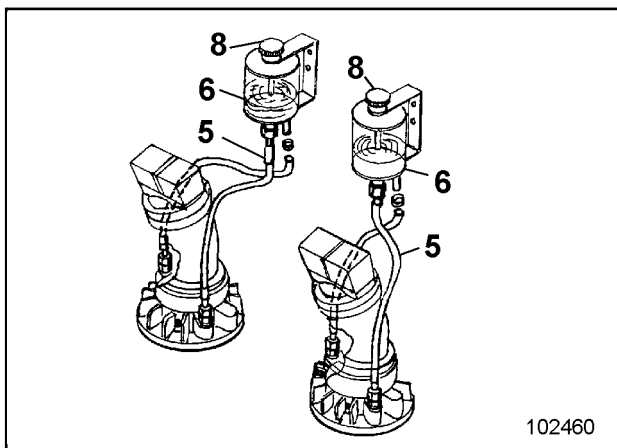

Fig. 4

Gearbox venting

The gearbox is vented through cap (8, Fig. 4).

Venting bore

Check the venting bore in cap (8) for contamination and clean, if required. □

Unblocking a grease line.



Put the excavator back into operation only after the lubricating system works properly and after having actuated the unloaded working equipment for abt. 5 minutes. This is necessary in order to supply sufficient amounts of grease to the cylinder bearings.

Cleaning the grease sieve

Check the grease sieve regularly for contamination and clean, if required. The grease sieve must also be cleaned after an obstruction in one of the grease lines.

Cleaning

- Loosen plug (5, Fig. 7).
- Withdraw sieve and clean with white spirit or paraffin oil.
- Re-insert sieve and fasten with nut (5).

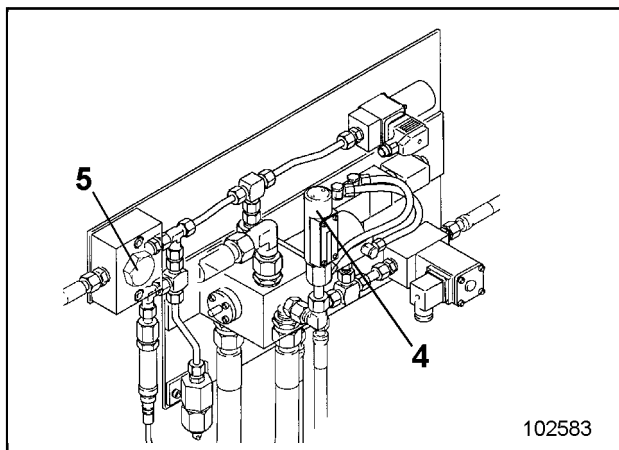

Fig. 7

Manual lubricating of lube points on backhoe / grab and undercarriage (optional)

Greasing lube points on backhoe / grab and undercarriage

Lube points (Fig. 8) must be greased regularly using grease pistol (16, Fig. 8 and 9) or a grease gun.

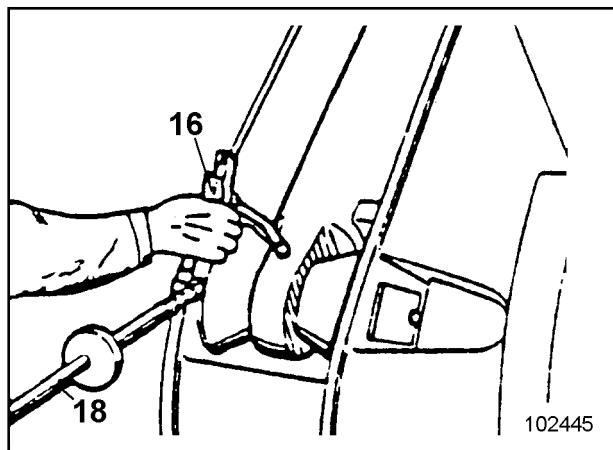

Fig. 8

Manual greasing with the pistol

- Press button (1, Fig. 9) on switch box under the hose reel (3). The pilot lamp (2) comes on.
- Take pistol (16) from holder (17) and pull hose (18) off reel (3).

There are approx. 10 metres (23 metres optional) of hose on reel (3). This length is sufficient to reach the manual lube points mentioned above when the working equipment is on the ground (Fig. 8).

To reel hose back in again, give it a short tug and then release (inertia reel).

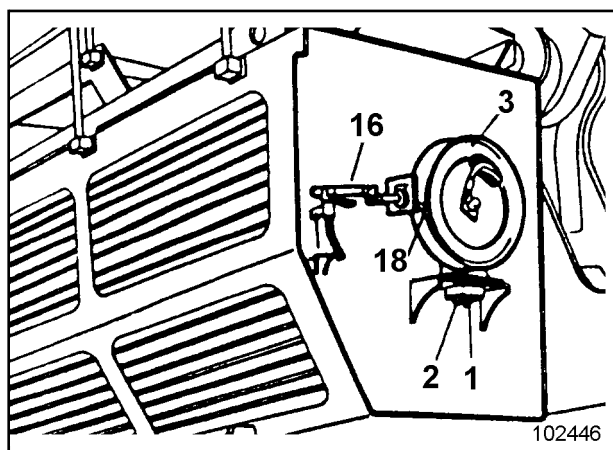

Fig. 9

PART 4 - REPAIR WORK

	Operating manual	Target group
Part 1	INTRODUCTION FUNDAMENTAL SAFETY INSTRUCTIONS	Operating personnel + Inspection and servicing personnel + Repair personnel
Part 2	OPERATION	Operating personnel The operating personnel must have know-how relevant to the operation and the application of this or comparable machines.
Part 3	INSPECTION AND SERVICING	Inspection and servicing personnel The inspection and servicing personnel must have know-how relevant to the inspection and servicing of this or comparable machines.
Part 4	REPAIR WORK	Repair personnel The repair personnel must have know-how and experience relevant to the repair of this or comparable machines.
Part 5	ANNEX	Operating personnel + Inspection and servicing personnel + Repair personnel
Part 6	INDEX	Operating personnel + Inspection and servicing personnel + Repair personnel

□





NOTES

A series of horizontal dotted lines providing space for handwritten notes.

□

CLICK HERE TO **DOWNLOAD** THE COMPLETE MANUAL

- Thank you very much for reading the preview of the manual.
- You can download the complete manual from: www.heydownloads.com by clicking the link below



- Please note: If there is no response to CLICKING the link, please download this PDF first and then click on it.

CLICK HERE TO **DOWNLOAD** THE COMPLETE MANUAL