

Operating Instructions

CE

Hydraulic Excavator

RH 40E No.

Bucyrus HEX GmbH



CLICK HERE TO **DOWNLOAD** THE COMPLETE MANUAL

- Thank you very much for reading the preview of the manual.
- You can download the complete manual from: www.heydownloads.com by clicking the link below



- Please note: If there is no response to CLICKING the link, please download this PDF first and then click on it.

CLICK HERE TO **DOWNLOAD** THE COMPLETE MANUAL

| | |
|-----------------------------------------|-----|
| Fuel system - Safety instructions | 110 |
| Changing the fuel filter | 110 |
| Venting the fuel system | 111 |
| Cleaning the fuel tank..... | 111 |
| Water trap (option) | 112 |
| Servicing..... | 112 |
| Draining off water | 112 |

ELECTRICAL SYSTEM

| | |
|-----------------------------------------------|-----|
| Electrical system - Safety instructions | 113 |
| Alternator - Instructions | 113 |
| Battery main switch / Main fuse | 114 |
| Battery | 114 |
| Checking the battery fluid level..... | 114 |
| Checking the battery charge | 115 |
| Removing and installing the battery | 115 |

HYDRAULIC SYSTEM

| | |
|---------------------------------------------------------------------------------------------|-----|
| Hydraulic system - Safety instructions | 117 |
| Depressurizing the hydraulic system | 117 |
| Checking the hydraulic oil level | 118 |
| Topping up with hydraulic oil | 118 |
| Changing the hydraulic oil return-flow filters..... | 119 |
| Bypass valves (working circuit) | 120 |
| Cleaning the sieve | 120 |
| Replacing the bypass valves and the sealing rings | 120 |
| Bypass valve (cooling circuit) | 121 |
| Cleaning the valve | 121 |
| Changing the valve..... | 121 |
| Breather filter | 122 |
| Replacing the filter element | 122 |
| High-pressure filter for working hydraulics | 123 |
| Checking/changing the filter elements | 123 |
| Replacing the filter element | 123 |
| High-pressure filter for the servo circuit and the feeding circuit of the slewing pump..... | 124 |
| Checking the filter element..... | 124 |
| Replacing the filter element | 124 |
| Changing the hydraulic oil | 125 |
| Draining off the hydraulic oil | 125 |
| Cleaning the hydraulic oil reservoir | 126 |
| Filling in hydraulic oil | 126 |
| Venting the hydraulic system | 127 |
| Venting the hydraulic components | 127 |
| Cleaning the hydraulic oil cooler..... | 128 |
| Cleaning | 128 |

Organizational measures

The operating instructions must always be at hand at the place of use of the machine, e.g. by stowing them in the place provided for such purpose.

In addition to the operating instructions, observe and instruct the user in all other generally applicable legal and other mandatory regulations relevant to accident prevention and environmental protection.

These compulsory regulations may also deal with the handling of hazardous substances, issuing and/or wearing of personal protective equipment or traffic regulations.

The operating instructions must be supplemented by instructions covering the duties involved in supervising and notifying special organizational features, such as job organization, working sequences or the personnel entrusted with the work.

Personnel entrusted with work on the machine must have read the operating instructions and in particular the chapter on safety before beginning work. Reading the instructions after work has begun is too late. This applies especially to persons working only occasionally on the machine, e.g. during setting up or maintenance.

Check - at least from time to time - whether the personnel is carrying out the work in compliance with the operating instructions and paying attention to risks and safety factors.

For reasons of security, long hair must be tied back or otherwise secured, garments must be close-fitting and no jewellery, such as rings, may be worn. Injury may result from being caught up in the machinery or from rings catching on moving parts.

Use protective equipment wherever required by the circumstances or by law.

Observe all safety instructions and warnings attached to the machine.

See to it that safety instructions and warnings attached to the machine are always complete and perfectly legible.

In the event of safety-relevant modifications or changes in the behaviour of the machine during operation, stop the machine immediately and report the malfunction to the competent authority/person.

Never make any modifications, additions or conversions which might affect safety without the supplier's approval. This also applies to the installation and adjustment of safety devices and - valves as well as to welding work on load-bearing elements.

Spare parts must comply with the technical requirements specified by the manufacturer. Spare parts from original equipment manufacturers can be relied on to do so.

Replace hydraulic hoses within stipulated and appropriate intervals, even if no safety-relevant defects have been detected.

Adhere to prescribed intervals or those specified in the operating instructions for routine checks and inspections.

For the execution of maintenance work, tools and workshop equipment adapted to the task on hand are absolutely indispensable.

The personnel must be familiar with the location and operation of fire extinguishers.

Observe all fire-warning and fire-fighting procedures.

Fire and Explosion Hazard

2796685



Safety Instructions

Avoid smoking and open fire on, next to and below the machine.

Combustible and easily flammable substances or liquids increase the fire and explosion hazard.

Do not store such substances on the excavator.

Clean the excavator thoroughly, if possible, with a steam jet (rubber parts and electric components with compressed air - refer to information label), when, for example, oil, grease, fuel or cleaner was spilled. Such substances may spontaneously ignite if they get into the vicinity of hot units or objects such as turbo superchargers.

Even battery gases can ignite in open flames or fire.

Avoid parking the excavator in places where

- combustible substances such as coal dust or tar are present.
- open or smouldering fire may occur.









Remove the excavator from such an area where combustible or easily flammable liquids have spilled from the excavator onto the ground.

Flying sparks may cause fire on the ground that can spread to the excavator.

□

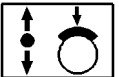

(Fig. 5)

| No. | Element | Function | Symbol |
|-----|----------------------------------------------------|---------------------------------------------------------------------------------------------------------------------------------------------------------------------------------------------------------------------------------------------------------------------------------|---------------------------------------------------------------------------------------|
| 53 | Switch Stop | Engine shut-off |  |
| 54 | Switch Electronic speed regulation (Centry) | Press switch after a fault has been reported. Warning lamp (2) flashes in a coded sequence. The coded sequence indicates the cause of the fault. Contact the O&K Technical Service or the engine manufacturer |  |
| 55 | | Free for optional equipment | |
| 56 | | Free for optional equipment | |
| 57 | Switch Speed reset | To the left: normal operation automatic speed reduction of diesel engine; active during working pauses To the right: automatic speed-reduction function off | |
| 58 | Switch Pre-heating system (optional) | Pre-heating of the fuel system | |
| 59 | Switch Windscreen wiper | Permanent operation/intermittent operation |  |
| 60 | Switch Floodlamp | Front of superstructure on the right |  |
| 61 | Switch Windscreen washer | Wipe/wash operation |  |
| 62 | Switch Floodlamp | Counterweight |  |
| 63 | Switch Track parking brake | To block the undercarriage.  Actuate switch only when the excavator is stationary. The track brake is automatically released when the undercarriage travel function is switched on |  |
| 64 | Switch Floodlamp | Driver's cab, instrument lighting |  |

Shutting off the engine

During interruptions of the work and after the work, stand working equipment on the ground.

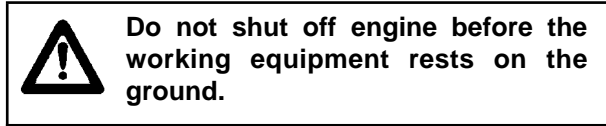

- Turn speed control knob (71, Fig. 7) counter-clockwise to the limit stop (idling).

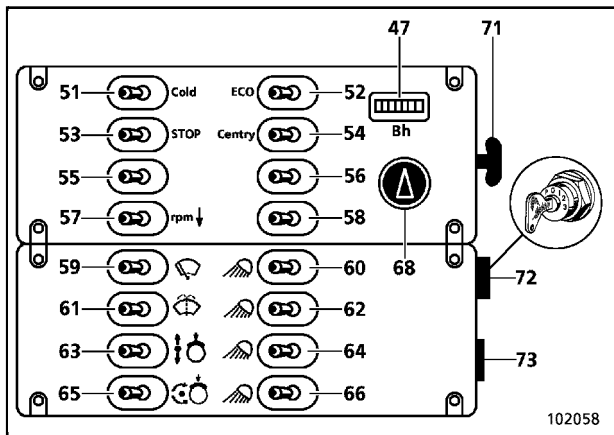
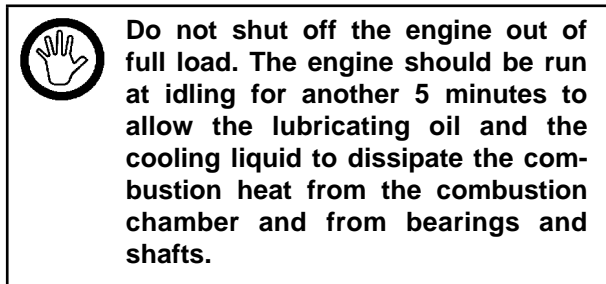

Fig. 7



- Turn key in key-switch (72) to position "0" (electrical system without current).

Emergency stop

In case of emergency, e.g. if buzzer (50, Fig. 8) sounds, the engine can be shut off from full load.

To do so:

- actuate stop-button (53, Fig. 7) and hold in this position until the engine has come to a standstill;
- turn key in key-switch (72) to position "0" (electrical system without current).

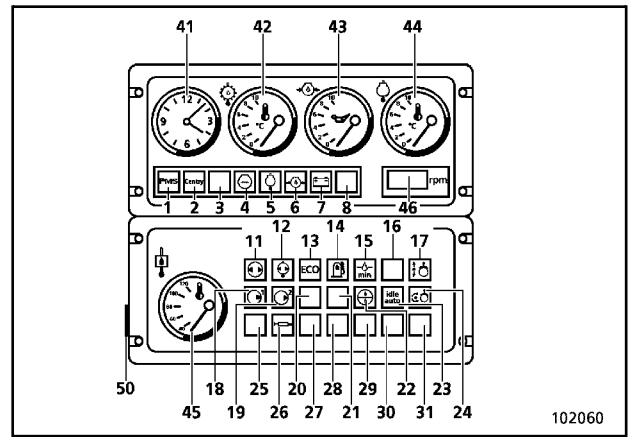

Fig. 8



At low temperatures, bring the engine down to moderate speed, then activate all hydraulic functions for about 10 minutes (bring to service temperature). For further instructions, see section "Lubricants".

If the warning lamps for engine temperature, engine oil pressure, coolant level, alternator or hydraulic oil filter control (with hydraulic oil at service temperature) light up: Lower the working equipment and shut off engine.



Parts of the attachment may damage the machine if they are moved into extreme positions (see illustration 1 and 2).

Work carefully, avoiding extreme positions of this kind.

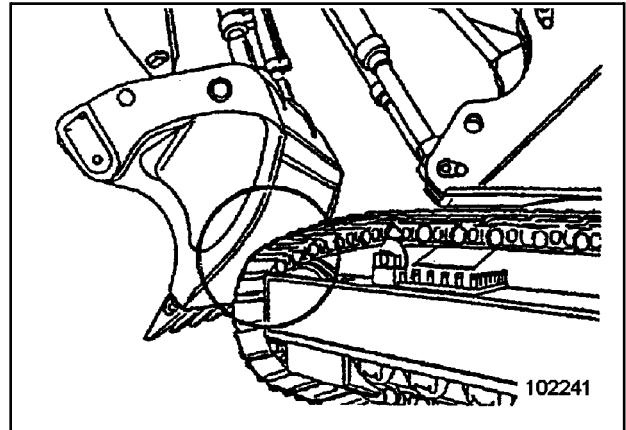

Fig. 1

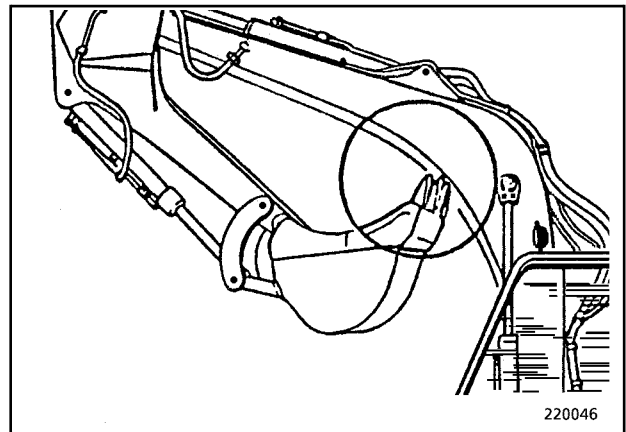

Fig. 2

□

Pipe break protection

The pipe break protection prevents the working equipment from lowering if a hydraulic line to the boom cylinder breaks.

The hydraulic connection on the rod side of the boom cylinder is blocked, so that the hydraulic oil can flow out only if the "Boom lowering" function is initiated.

If a hydraulic line has broken:

- Warn persons in the vicinity of the excavator by sounding the horn. Stop working.
- Secure the working equipment with the attached load. Persons must be prevented from entering the hazard zone under the working equipment or the load.
- Replace the broken hydraulic line (or have it replaced) before continuing the work.
- Collect escaping hydraulic oil. Dispose of oily cleaning rags, oil binding agents, etc. without polluting the environment.

Speed-reduction function



Do not activate the speed-reduction function when the machine is used for lifting-gear operation and for travelling.

The speed-reduction function can cause the hydraulic output to decrease suddenly.

The speed-reduction function reduces the drive engine revolutions to idling if the working equipment remains inactivated during 10 seconds.

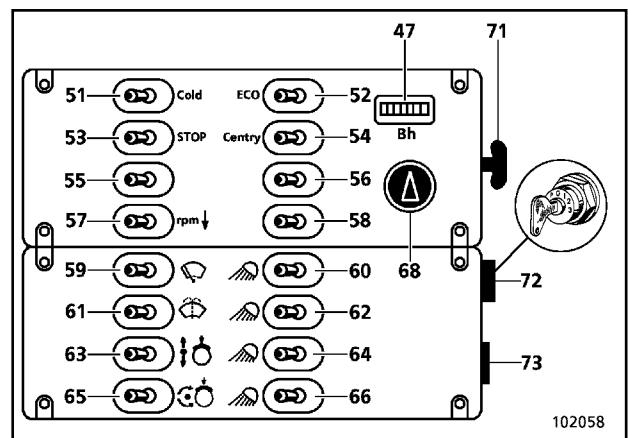

Fig. 3

To switch on the speed-reduction function:

- Press toggle switch (57, Fig. 3) to the left.

Monitoring lamp (23, Fig. 4) lights up when the speed-reduction function is activated.

To switch off the speed-reduction function:

- Press toggle switch (57) to the right.

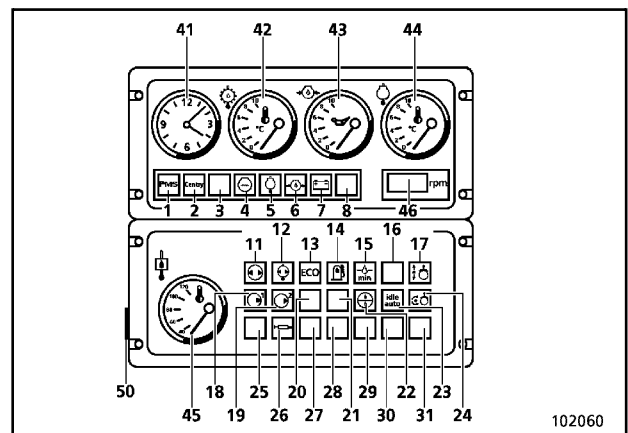

Fig. 4

CLICK HERE TO **DOWNLOAD** THE COMPLETE MANUAL

- Thank you very much for reading the preview of the manual.
- You can download the complete manual from: www.heydownloads.com by clicking the link below



- Please note: If there is no response to CLICKING the link, please download this PDF first and then click on it.

CLICK HERE TO **DOWNLOAD** THE COMPLETE MANUAL

Inspection and servicing plans - Instructions

Intervals

The inspection and servicing plan lists all jobs which have to be done on the machine at regular intervals.

The individual inspection and servicing plans are marked with letters providing a link between the operating hours (OH) recorded by the hours-run meter of the machine and the inspection and servicing plans.

| Plan | Do all jobs |
|-------------------------------------------------------------------|--------------------------------------------------------------------|
| V | once prior to initial commissioning. |
| N | after initial commissioning and during the running-in period. |
| T | every 10 OH or every working shift ¹⁾ . |
| W | every 50 OH or weekly ¹⁾ . |
| A | after every 250 OH. |
| B | after every 500 OH. |
| C | after every 1000 OH. |
| D | after every 3000 OH. |
| E | after every 6000 OH. |
| ¹⁾ Whichever comes first. OH = Bh = Operating hours | |

Change of engine oil

The intervals stated for **changing the engine oil** apply to fuels with a sulphur content of $\leq 0.5\%$ and a permanent ambient temperature down to -10°C .

In case of higher sulphur content and/or a permanent ambient temperature of below -10°C , shorter intervals are required.

If the engine oil change intervals are not reached within **6 month** the oil must be changed **after 6 months at the latest** .

Air-intake system

The air filter must be serviced only if the vacuum-meter so indicates.

Oils / Greases

For the specification of oils and greases to be used refer to the "Lubricants" section.

The numerals mentioned in the "Oil / Grease" column in the inspection and servicing plans have the following meaning:









| | |
|-----|---------------------------------------------|
| I | Oils for combustion engines and compressors |
| II | Oils for hydraulic systems |
| III | Oils for gearboxes |
| V | Greases for bearings and slewing rings |
| VII | Oils for refrigerating compressors |

Cleaning jobs

Cleaning jobs, especially on cooling systems, must be done at shorter intervals if the machine is exposed to severe dust build-up.

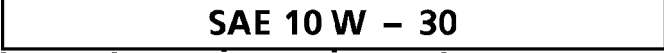

III. Oils for gearboxes (selection)

| Ambient temperature | | °F | -22 | -4 | +14 | +32 | +50 | +68 | +86 | +104 | +122 |
|----------------------|----------------|-------------------------------------------------------------------------------------------------------------------------------------------------------------------------------------------------------------------------------------------------------------------------------------------------------------------------------------------------------------|-----|-----|-----|-----|-----|-----|-----|------|------|
| | | °C | -30 | -20 | -10 | 0 | +10 | +20 | +30 | +40 | +50 |
| Specification | | | | | | | | | | | |
| API | MIL - L | | | | | | | | | | |
| GL 5 | 2105 C |  O&K Multigrade Gear-Oil P/No.1 589 636 | | | | | | | | | |
| GL 5 GL 4 | 2105 B 2105 |    | | | | | | | | | |
| API | MIL - L |  | | | | | | | | | |
| CD | 2104 C |     | | | | | | | | | |

8003081

Cooling liquid



Read and observe the "Inspection and servicing - Safety instructions" chapter.

Risk of scalding caused by hot cooling liquid.

The cooler itself may also be hot.

Wear protective gloves and firm working clothing.

Collect escaping cooling liquid and discard without polluting the environment.

Change the cooling liquid regularly and after 2 years at the latest.

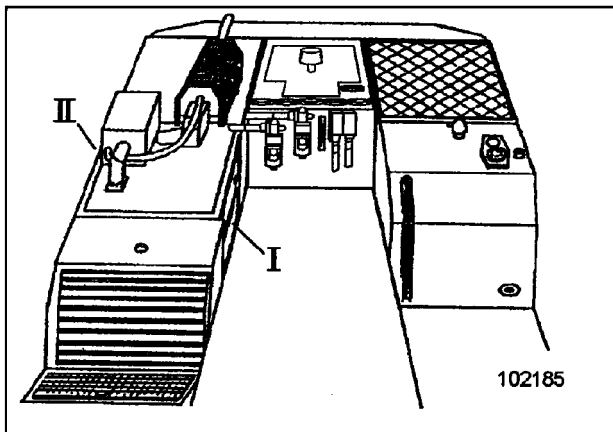

Fig. 2

To do so:

- Prepare a collecting recipient for used cooling liquid. Choose the required recipient capacity in accordance with the "Refilling quantities - Other" table.
- Shut off the engine.
- Open hatch II (Fig. 2).
- Unscrew plug (arrow, Fig. 3) and drain off cooling liquid completely.
- Fill in cooling liquid after having re-inserted the plug with a new sealing ring.

The engine operating instructions describe in detail how to prepare cooling water and how to check the cooling liquid. Check in case of imminent frost whether the concentration of the anti-freeze compound added to the cooling liquid at the factory is sufficient for the temperatures to be expected.

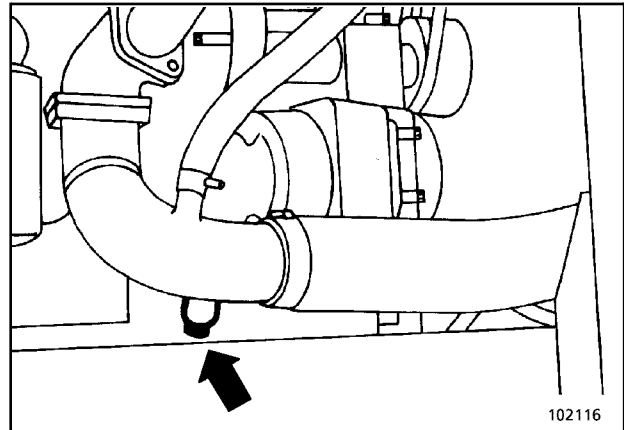

Fig. 3

Checking the cooling liquid

Check the cooling liquid in the cooling system regularly to ensure that the water-filter change interval resp. the DCA4-concentration is sufficient to prevent corrosion under the existing operating conditions.

Checking the battery charge

The acid temperature must be 20°C.

- Unscrew caps of the battery (Fig. 4).
- Measure the acid density of the battery using a commercial acid tester (Fig. 4).

The acid density measured is in direct correlation with the battery charge.

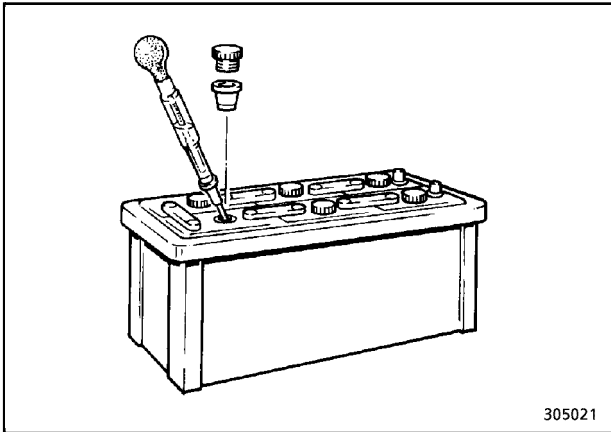

Fig. 4

| Acid density | | |
|-------------------------|---------------------|----------------------------------|
| in kg / dm ³ | | Charge |
| Normal conditions | Tropical conditions | |
| 1.28 | 1.23 | fully charged |
| 1.20 | 1.12 | half charged, recharge |
| 1.12 | 1.08 | discharged, recharge immediately |

Removing and installing the battery



Read and observe the "Inspection and servicing - Safety instructions" chapter.

Wear protective gloves and firm working clothing.

Shut off the engine before removing the batteries to avoid damaging the alternator and the regulator.

Turn key in key-switch to position "0" and withdraw.

Set battery main switch (Fig. 5) to position II "OFF".

Disconnect and reconnect the terminal clamping lugs in the prescribed order.

Disconnecting and connecting in the wrong order may cause short-circuits.

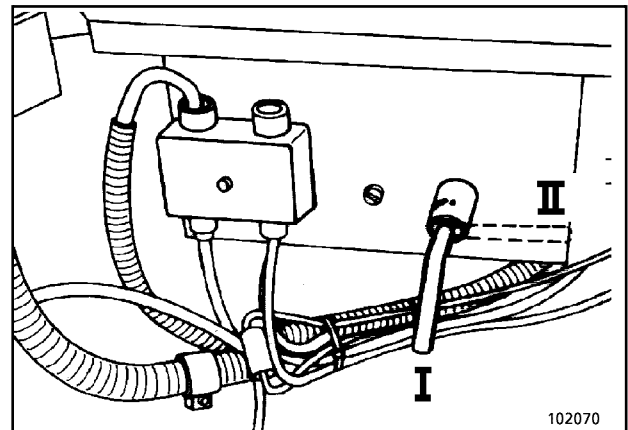

Fig. 5

Changing the hydraulic oil



Read and observe the "Inspection and servicing - Safety instructions" chapter.

Shut off the engine.

Risk of scalding caused by hot hydraulic oil.

The hydraulic reservoir itself may also be hot.

Avoid skin contact.

Contact with hydraulic oil can cause skin injury.

Wear protective gloves and firm working clothing.

Collect escaping oil and discard without polluting the environment.



Do not start up the drive engine when the hydraulic oil reservoir is empty. The hydraulic pumps may be destroyed if they are allowed to run dry.

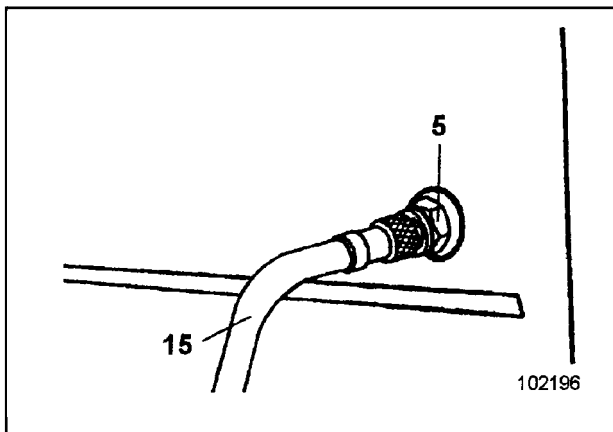

Fig. 16

Draining off the hydraulic oil

- Bring the hydraulic oil to operating temperature (abt. 50°C).
- Position the machine with a slight inclination towards the drain valve (5, Fig. 16). The drain valve is located at the back of the hydraulic oil reservoir and accessible from the bottom.
- Retract the hydraulic cylinders as far as possible and stand the working equipment on the ground.
- Shut off the engine.
- Place a suitable recipient under the drain valve of the hydraulic oil reservoir (5). Choose the required capacity of the recipient in accordance with the "Refilling quantities - Oil" table.
- Connect hose (15) to drain valve (5) and drain off used oil completely. Draining is facilitated if the breather filter (6, Fig. 17) is removed during the process. The use of the oil draining hose is described in the "Draining hose for oil changes" section. When the machine is in operation, the hose (15, Fig. 16) must be stowed away in the tool box.
- Remove hose. The drain valve closes automatically.

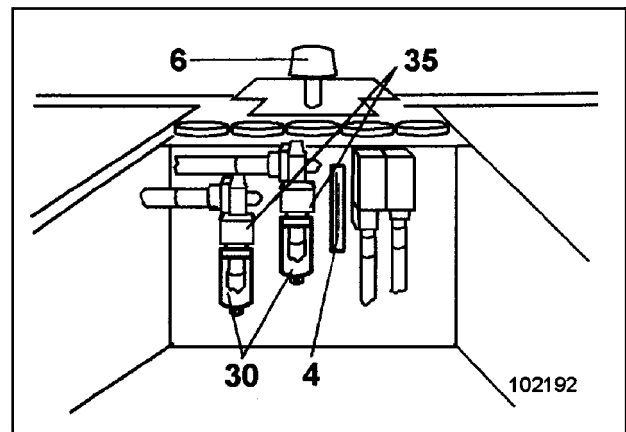

Fig. 17

Track pads

Check fastening screws (5, Fig. 4) regularly for tightness:

- Tighten screws with a torque wrench to the prescribed tightening torque (cf. table "Tightening torques").

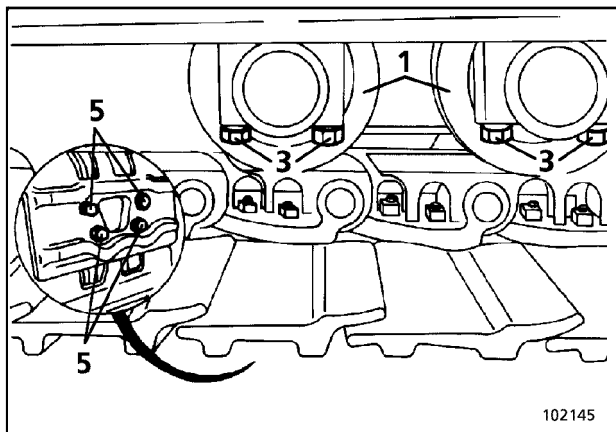

Fig. 4

Track tensioner

System configuration

The tracks are tensioned automatically when a travel movement is initiated. In this case, oil and a required pressure from the servo pump are diverted via a corresponding hydraulic switching device to the track-tensioning circuit. Figs. 5 and 6 show parts of the tracks and the tensioner:

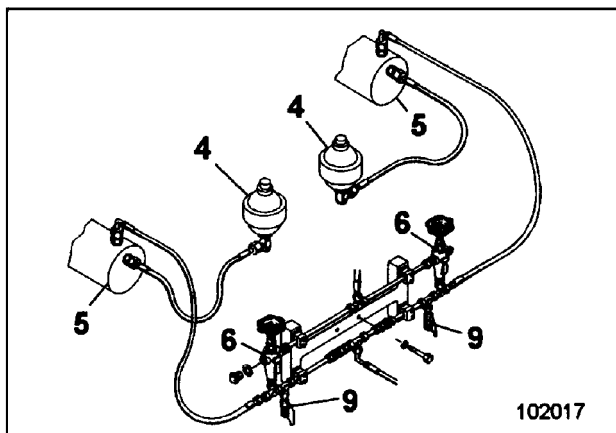

Fig. 5

- 4 Diaphragm accumulator
- 5 Pressure cylinder
- 6 Pressure-limiting valve
- 9 Mini-measuring port
- 10 Idler
- 11 Sprocket
- 12 Track roller
- 13 Track
- 14 Support roller

Technical data

| | |
|-------------------------------------------------------------------|--------------|
| Track tensioning pressure | ca. 100 bars |
| Pressure limiting valve | 250 bars |
| Gas pressure in diaphragm accumulator (nitrogen filling pressure) | 80 bars |

Function

The tensioning system is under a permanent pressure of ca. 100 bars which keeps both tracks permanently tensioned. Pressure losses are compensated as soon as the track drives are switched on. Retensioning is not required.

For cleaning and servicing work, the tracks can be slackened.

To do so:

- stop the engine
- open both pressure limiting valves (6, Fig. 5) to slacken the tracks.
- After the work, screw down the pressure limiting valves (6) to the limit stop.

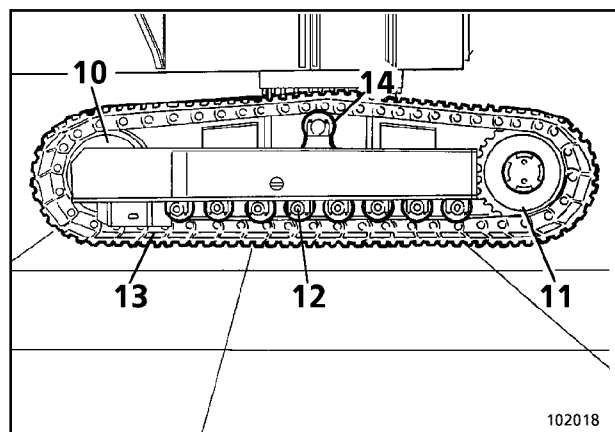

Fig. 6

The pressure-limiting valves (6) are preset to a pressure of 250 bars and sealed in this position. The lead seal must not be removed and the pressure setting of 250 bars must not be changed.

The track tensioners are otherwise maintenance-free.

PUTTING THE EXCAVATOR OUT OF OPERATION AND RECOMMISSIONING

Putting the excavator out of operation

- Park excavator on firm and level ground.
- Stand working equipment on the ground retracting the piston rods of the hydraulic cylinders as far as possible.
- Set all control levers to position "0".
- Clean the machine.
- Lock the superstructure.
- Carry out a visual inspection of the excavator.
- Remove gross dirt, snow and ice from the fins and the fan wheel of the hydraulic oil cooler.
- Carry out engine preservation.
- Protect all bright metal parts (e.g. piston rods) against rust and dirt.
- Check anti-freeze concentration of the cooling liquid to avoid freezing during the cold season.
- Fill up the fuel tank.
- Remove the batteries. Cf. also **Battery storage**.
- Secure the machine against unauthorized starting by:
 - withdrawing the key from the key-switch
 - setting the battery main switch to OFF and withdrawing the key handle
 - locking the cab door
 - securing all lockable hatches.
- Cover up openings.

Battery storage

During prolonged downtimes of the machine, remove the batteries and store in a dry room at ca. 20°C ambient temperature. Observe the following maintenance points:

- Clean the batteries.
- Check acid density and battery fluid level once a fortnight.
- Recharge the batteries at the latest when the acid density has fallen to 1.23 kg/dm³.
- Keep the outside of batteries clean and dry.

Recommissioning

- Remove covers.
- Degrease resp. clean all protected components.
- Remove engine preservative in acc. with the engine operating instructions.
- Unlock the superstructure.
- Check the fuel level in the tank.
- Check tensioning of the tracks (visual inspection).
- Check level and condition of the cooling liquid in the cooling system.
- Check grease filling in grease container.
- oil level
 - drive engine
 - slewing gearbox
 - pump transfer gearbox
 - travel gearboxes
- Check oil level in hydraulic oil reservoir.
- Check acid density and battery fluid level.
- Install the batteries and reconnect.
- Set battery main switch to ON.
- Control and monitoring elements:
carry out a function check of all monitoring and warning lamps and the buzzer by turning the key-switch to the respective position.
- Function checks:
 - superstructure holding brake
 - track brake
 - lighting system
 - signalling equipment
- Check the vacuummeter.
- Vent the hydraulic system. □

WELDING OPERATIONS

Welding operations - Safety instructions

2413692



Never perform welding operations unless you are qualified to do so.

Observe the accident prevention regulations.

Any work on receptacles that contain or have contained substances which are

- combustible or which encourage combustion, which
- are susceptible to explosion, or which
- may develop health-hazardous gases, vapours, mist or dust during welding operations

must be carried out only under expert supervision and only by experienced persons authorized to do such work.

Detailed information on the correct execution of welding operations is given in the technical manual "Welding for maintenance and repair".

Should you have any problems or queries, apply to the O&K after-sales service department.

If parts of the machine have to be dismantled, read and take note of the following sections:

"Assembling attachments, safety instructions",
"Inspection and servicing, safety instructions",
"Repair, safety instructions".



Prior to any welding operations on the machine:

- Set battery main switch to OFF

Protect the disconnected terminals and plugs from short-circuiting and soiling by covering them with foil or adhesive tape.

Attach the welding-current pincers close to the welding zone (max. 2 - 3 m)

The welding current must not flow via the ball resp. the roller bearing slewing ring, via pin couplings, articulated joints or hydraulic cylinders.

An electric current flowing over an air gap (in an articulated joint, for instance) generates sparks that damage metallic surfaces.

On completion of the welding operation, restore all electrical connections.

- Set battery main switch to ON

□



CLICK HERE TO **DOWNLOAD** THE COMPLETE MANUAL

- Thank you very much for reading the preview of the manual.
- You can download the complete manual from: www.heydownloads.com by clicking the link below



- Please note: If there is no response to CLICKING the link, please download this PDF first and then click on it.

CLICK HERE TO **DOWNLOAD** THE COMPLETE MANUAL