

Operating Instructions

CE

Hydraulic Excavator

RH 120E No.

Bucyrus HEX GmbH



CLICK HERE TO **DOWNLOAD** THE COMPLETE MANUAL

- Thank you very much for reading the preview of the manual.
- You can download the complete manual from: www.heydownloads.com by clicking the link below



- Please note: If there is no response to CLICKING the link, please download this PDF first and then click on it.

CLICK HERE TO **DOWNLOAD** THE COMPLETE MANUAL

1 INTRODUCTION

	Operating instructions	Target group
Part 1	INTRODUCTION FUNDAMENTAL SAFETY INSTRUCTIONS	Operating personnel + Inspection and servicing personnel + Repair personnel
Part 2	OPERATION	Operating personnel The operating personnel must have know-how relevant to the operation and the application of this or comparable machines.
Part 3	INSPECTION AND SERVICING	Inspection and servicing personnel The inspection and servicing personnel must have know-how relevant to the inspection and servicing of this or comparable machines.
Part 4	REPAIR WORK	Repair personnel The repair personnel must have know-how and experience relevant to the repair of this or comparable machines.
Part 5	ANNEX	Operating personnel + Inspection and servicing personnel + Repair personnel
Part 6	INDEX	Operating personnel + Inspection and servicing personnel + Repair personnel



Gas, dust, steam and smoke

Always start and operate the engine in a well-ventilated area;

If in an enclosed area, vent the exhaust to the outside;

Do not modify or tamper with the exhaust system

California Proposition 65 WARNING

Diesel engine exhaust and some of its constituents are known in the state of California to cause cancer, birth defects, and other reproductive harm.

Operate fuel-operated heating systems only on adequately ventilated premises. Before starting the machine on enclosed premises, make sure that there is sufficient ventilation.

Observe the regulations in force at the respective site.

Carry out welding, flame-cutting and grinding work on the machine only if this has been expressly authorized, as there may be a risk of explosion and fire.

Before carrying out welding, flame-cutting and grinding operations, clean the machine and its surroundings from dust and other inflammable substances and make sure that the premises are adequately ventilated (risk of explosion).

Hydraulic equipment

Check all lines, hoses and screwed connections regularly for leaks and obvious damage. Repair damage immediately. Splashed oil may cause injury and fire.

Depressurize all system sections and pressure pipes (hydraulic system) to be removed in accordance with the specific instructions for the unit concerned before carrying out any repair work.

Hydraulic lines must be laid and fitted properly. Ensure that no connections are interchanged. The fittings, lengths and quality of the hoses must comply with the technical requirements.

Noise

During operation, all sound baffles of the machine must be closed.

Always wear the prescribed ear protectors.

Oil, grease and other chemical substances

When handling oil, grease or other chemical substances, observe the product-related safety regulations (see safety specifications).

Be careful when handling hot consumables (risk of burning or scalding).

Transporting and recommissioning

The machine must be loaded and transported only in accordance with the operating instructions.

Use only appropriate means of transport and lifting gear of adequate capacity.

The recommissioning procedure must be strictly in accordance with the operating instructions.

Excavator layout

Fig. 2-1:

Undercarriage

- 1 - Track drive
- 2 – Idler
- 3 - Track roller
- 4 - support roller
- 5 - Crawler track
- 6 - Track tensioner
- 7 - Slewing ring
- 8 - Ladder

Superstructure

- 10 - Engine
- 11 - Radiator (engine cooling liquid)
- 11 - Reservoir (cooling liquid)
- 13 - Air-intake system
- 14 - Exhaust system
- 15 - Fuel tank
- 16 - Hydraulic oil reservoir
- 17 - Hydraulic oil cooler
- 18 - Engine oil reservoir (optional)
- 19 - Pump transfer gearbox
- 20 - Working pump
- 21 - Cooling oil pump
- 22 - Servo system pump
- 23 - Servo system pump
- 24 - Gearbox circulating pump
- 25 - Slewing pump
- 26 - Fan drive pump (cooler, hydraulic oil)
- 27 - Fan drive pump (radiator, engine cooling liquid)
- 28 - Air compressor drive (air conditioning system)
- 29 – Slewing gear
- 30 – Travel block and rotor
- 31 – Driver` cab
- 32 – Control stand with BCS
- 33 – Control cabinet
- 34 – Air conditioner (optional)

- 35 – Fire-extinguisher
- 36 – Control cabinet with battery main switch
- 37 - Batteries
- 38 - Service-station, (tanklift)
- 39 - Ladder
- 40 - Ladder
- 41 - Grease container for central lubricating system
- 42 - Tool cabinet (optional)
- 43 - Counterweight
- 44 - On-board crane (optional)
- 45 - Drive unit (onboard crane, optional)

Loading bucket

- 51 – Boom
- 52 - TriPower linkage
- 53 – Stick
- 54 - Bottom-dump bucket
- 55 - Boom cylinder
- 56 - Stick cylinder
- 57 - Tipping cylinder
- 58 - Bottom-dump cylinder
- 64 - Control valves
- 65 - Quick-action valve

Backhoe bucket

- 53 - Stick
- 55 - Boom cylinder
- 56 - Stick cylinder
- 59 - Monoblock boom
- 60 - Backhoe bucket
- 61 - Backhoe cylinder
- 62 - Toggle link
- 63 - Toggle lever
- 64 - Control valves
- 65 - Quick-action valve

Driver's seat

The driver's seat (Fig. 2-24:) can be adjusted in inclination, height and fore-and-aft position. The seat suspension can be adjusted to suit the driver's weight.



Never adjust the seat while driving. Concentrate on the road to avoid accidents.

Before carrying out any seat adjustments:

- stop the machine
- set the control lever to "0"

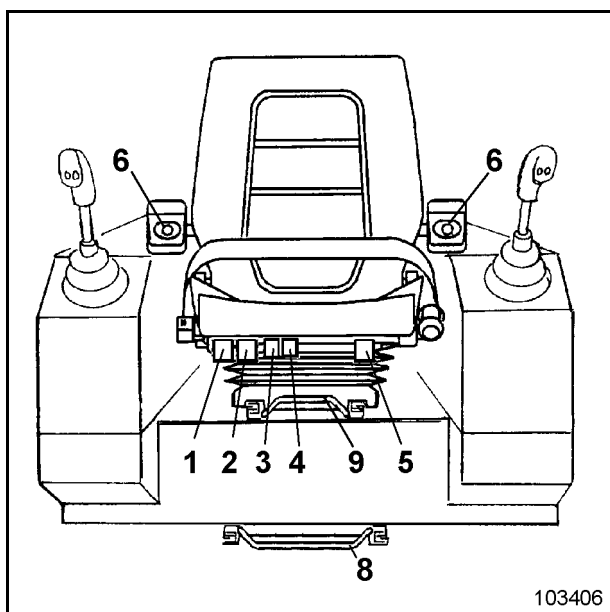

Fig. 2-24:

Adjusting the backrest

Adjust the inclination of the backrest with button (5) verstellen. Lean against the backrest or move your body forwards to bring the backrest into the desired position. Release button (5).

Adjusting the lumbar support

The backrest is equipped with an upper and a lower air chamber.

Pull knob (7) upwards - the lower chamber is inflated with air

Pull knob (3) upwards - the upper chamber is inflated with air

Push knobs (3 and 7) downwards - the air chambers are deflated

Adjusting the seat cushion

Adjust the inclination of the seat cushion with buttons (1 and 2).

Button (1) – lower frontside of cushion

Button (2) – lower backside of cushion

Bring the seat cushion into the desired position by moving the body forwards or backwards. Release button (1 or 2).

Adjusting the armrests

The armrests can be raised or lowered as required.

To adjust the armrest inclination, turn knobs (6) to the right or left.

Fore-and-aft position

The fore-and-aft position of the seat can be adjusted with lever (9).

Pull lever (9) upwards, slide seat to the desired position and allow lever (9) to engage.

Fore-and-aft adjustment of the seat plate

The fore-and-aft position is adjusted with lever (8).

Pull lever (8) upwards, slide seat plate to the desired position and allow lever (8) to engage.

Fig. 2-44

No.	Element	Function	Symbol
31	Botton Emergency OFF	Shuts off the whole electrical system	
32	Key-switch	Switches the electrical system on and off	
33	Buzzer	<p>Gives an acoustic warning signal if a fault is reported</p> <ul style="list-style-type: none"> ▪ Fault in engine system (engine 1 and/or 2; left and/or right) ▪ Coolant level (engine 1 and / or 2; left and / or right) too low ▪ Engine oil pressure (engine 1 and / or 2; left and / or right) too low ▪ Engine oil temperature (engine 1 and / or 2; left and / or right) too high ▪ Hydraulic oil level too low ▪ Distributor gearbox temperature (1 and / or 2; left and / or right) too high ▪ Slewing pump temperature (1 and / or 2; left and / or right) too high ▪ Slewing gearbox temperature (1 and / or 2) too high ▪ Fault in lubricating system <p> Lower the equipment to the ground and shut off engine immediately if the buzzer (33) sounds and the BCS indicates a fault. The buzzer (33) continues to sound until the fault has been retified.</p>	

Fig. 2-49:





















No.	Element	Function	Symbol
71	Switch Travel motors	Preselection: CW: 1st gear stage forward / reverse travel CCW: 2nd gear stage (fast gear) Only parallel forward travel is possible. When the switch is in this position and another travel function (e.g. reverse travel) is switched on, there is an automatic change to 1st gear.	
72	Switch Undercarriage holding brake	CCW: brake permanently applied The excavator can not be driven CW: Every time the excavator stops, the undercarriage brake is automatically applied after approx. 8 sec. The undercarriage brake is automatically released when the travel function is activated.  Actuate switch only when the excavator is stationary. Do not use as service brake.	
73	Taster Reset	Activate after a fault in the central lubricating system	
74	Switch Electronic excavator control	Switches on the electronic servo control	
75	Switch ECO (Power Control)	Adjusts the hydraulic power (flow rate) CCW – 80 % of hydraulic power CW 100 % of hydraulic power	
76	Cigarette lighter		
77	Switch Engine speed reduction	CCW: normal operation with automatic diesel engine speed reduction; active during operation pauses. CW: automatic speed reduction off	

Fig. 2-54:

No.	Element	Function	Symbol
131	Pressure gauge Engine oil pressure (engine 1 left)	Indicates the oil pressure in the diesel engine lubricating system	
132	Thermometer Engine temperature (engine 1 left)	Indicates the cooling-water temperature	
133	Pressure gauge Engine oil pressure (engine 2 right)	Indicates the oil pressure in the diesel engine lubricating system	
134	Thermometer Engine temperature (engine 2 right)	Indicates the cooling-water temperature	
135	Warning lamp Alternator (engine 1 left)	Lits up when the batteries are not recharged	
136	Warning lamp Engine oil pressure (engine 1 left)	Lits up when the engine oil pressure is too low	
137	Warning lamp IDLE-Auto (engine 1 left)	Lights during the engine's run-down phase of 5 minutes	
138	Warning lamp Engine temperature (engine 1 left)	Lits up when the engine temperature is too high	
139	Warning lamp Cooling water level (engine 1 left)	Lits up when the cooling-water level is too low	
140		free for optional	
141	Warning lamp Alternator (engine 2 right)	Lits up when the batteries are not recharged	
142	Warning lamp Engine oil pressure (engine 2 right)	Lits up when the engine oil pressure is too low	
143	Warning lamp IDLE-Auto (engine 2 right)	Lights during the engine's run-down phase of 5 minutes	
144	Warning lamp Engine temperature (engine 2 right)	Lits up when the engine temperature is too high	
145	Warning lamp Cooling water level (engine 2 right)	Lits up when the cooling-water level is too low	
146		free for optional	

Assemblies resp. reservoirs	Measuring device	Remarks
Fuel tank	BCS fuel indicator (Fig. 2-63:)	<p>Stop filling when the fuel tanks are full (service station shuts off automatically by counter-pressure).</p> <p>Optional</p> <p>The fuel level is also indicated on the fuel level gauges (21, Fig. 2-64:) for the right fuel tank and (22) for the left fuel tank.</p> <p>When the battery main switches are in position OFF the immersed tube sensors in both tanks are then electrical activated by toggle switch (23).</p> <p>This is necessary to check the fuel level in both tanks after all.</p>

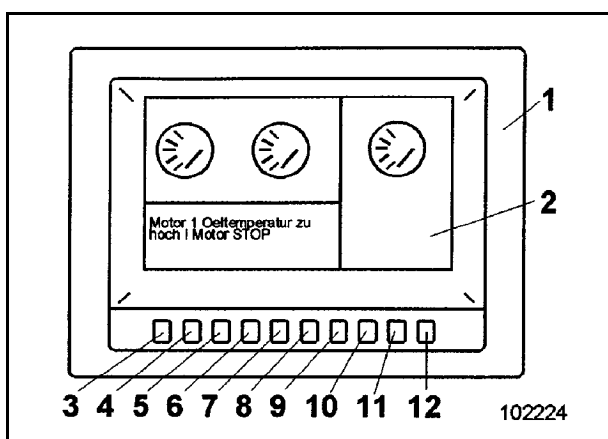

Fig. 2-63:

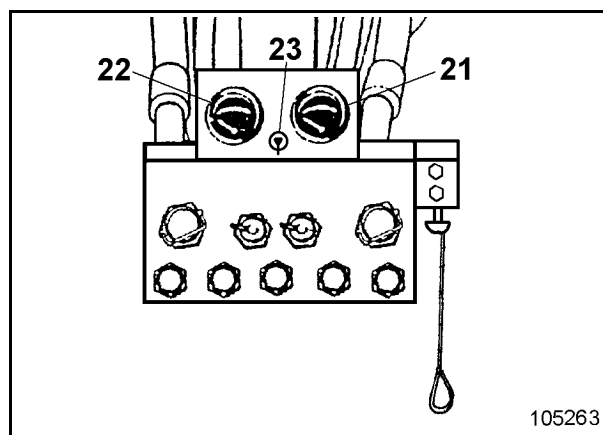

Fig. 2-64:

Back-up heating (option)

The back-up heating control elements are located in the satellite (182, Fig. 2-85:).

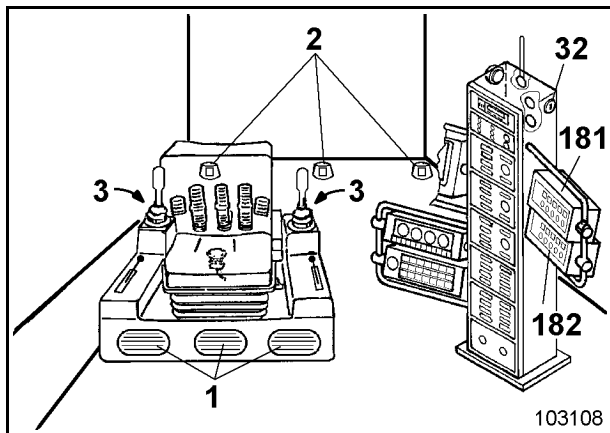
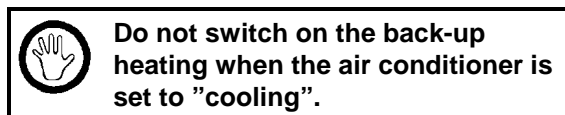

Fig. 2-85:



Control panel (Eberpächer)

(Fig. 2-86:)

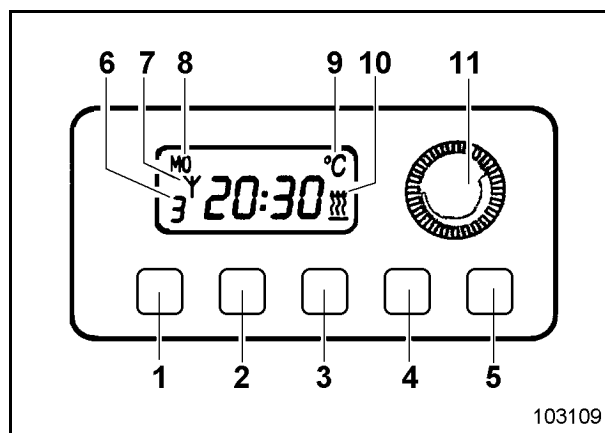

Fig. 2-86:

- | | | |
|----|------------|--------------------------|
| 1 | Pushbutton | set heating time |
| 2 | Pushbutton | heating time preselect |
| 3 | Pushbutton | heating on / off |
| 4 | Pushbutton | change set data |
| 5 | Pushbutton | Einstelldaten verändern |
| 6 | Symbol | change set data |
| 7 | Symbol | radio remote-control |
| 8 | Symbol | time and day of the week |
| 9 | Symbol | temperature |
| 10 | Symbol | operation |
| 11 | Selector | temperature |



TRANSPORTING THE MACHINE

Transport - Safety instructions

The machine must be loaded and transported only after all safety regulations have been observed and complied with.

Entrust loading and transporting of the machine to a company experienced in the transport of heavy equipment.

The responsibility for loading and transporting lies with the transport company or their representative.

Remove oil, grease, soil, mud, snow, ice and other materials from the excavator's crawler tracks and from ramps and loading platforms of the transport vehicle to minimize slipping.

Secure the transport vehicle against rolling away.

Use only tying equipment of sufficient strength (the weights and dimensions of the excavator are set out in the "Technical specifications").

Transport

The dimensions and the service weight of the fully assembled excavator do not allow the excavator to be transported in an undismantled state on a low-bed trailer over public roads.

Therefore, the following components and modules must be dismantled beforehand.

Weights and suspensions points are marked on the modules.

FIRE AND EXPLOSION HAZARD

Safety Instructions

Avoid smoking and open fire on, next to and below the machine.

Combustible and easily flammable substances or liquids increase the fire and explosion hazard.

Do not store such substances on the excavator.

Clean the excavator thoroughly, if possible, with a steam jet (rubber parts and electric components with compressed air - refer to information label), when, for example, oil, grease, fuel or cleaner was spilled.

Such substances may spontaneously ignite if they get into the vicinity of hot units or objects such as turbo superchargers.

Even battery gases can ignite in open flames or fire.

Avoid parking the excavator in places where

- combustible substances such as coal dust or tar are present.
- open or smouldering fire may occur.

Remove the excavator from such an area where combustible or easily flammable liquids have spilled from the excavator onto the ground.

Flying sparks may cause fire on the ground that can spread to the excavator.

CLICK HERE TO **DOWNLOAD** THE COMPLETE MANUAL

- Thank you very much for reading the preview of the manual.
- You can download the complete manual from: www.heydownloads.com by clicking the link below



- Please note: If there is no response to CLICKING the link, please download this PDF first and then click on it.

CLICK HERE TO **DOWNLOAD** THE COMPLETE MANUAL



Plan A – E

Plan A - after every 250 OH
 (at 250, 750, 1250 ... OH)

Plan B - after every 500 OH
 (at 500, 1500, 2500 ... OH)

Plan C - after every 1000 OH
 (at 1000, 2000, 3000, 4000 ... OH)

Plan D - after every 5000 OH
 (at 5000, 15000, 25000 ... OH)

Plan E - after every 10000 OH
 (at 10000, 20000, 30000, ... OH)

Location	Servicing work	Menge / No.	Plan A	Plan B	Plan C	Plan D	Plan E
Servicing in acc. with W or T			●	●	●	●	●
Monitoring, warning and control elements							
- Joystick							
- Control spool	oil lightly	2 x 4 ⁵			●	●	●
- Pedal							
- Control spool (machine with loading shovel)	oil lightly	3 x 2 ⁵			●	●	●
- Control spool (machine with backhoe bucket)	oil lightly	2 x 2 ⁵			●	●	●

⁵ apply a thin layer of hydraulic oil

Lubricating chart – Grease / Backhoe bucket (legend)

No.	Greasing point	Number	Lubricant properties	Grease every operating hours
1	Central lubricating system – grease container	1	V ¹⁶	10
3	Ramp-type ladder (optional)			
	- Deflecting roller	3	V ¹⁶	1000
	- Locking bolt	1	I ¹⁶	1000
4	On-board crane			250
	- Bearing	4	V ¹⁶	250
	- Joint (column / boom)	2		250
	- Cylinder bearing	5		250
	- Slewing ring	1	Graphitspray	250
5	Monitoring, warning and control elements			
	- Joystick	2 x 4 ¹⁷	II ¹⁶	1000
	- Pedal	3 x 2 ¹⁷		1000

All other greasing points are supplied with grease by the central lubricating system.

Filling quantities - Grease

Greasing point	Lubricant properties	Filling quant.	
		kg	lb
Central lubricating system – grease container	V ¹⁶	500	1102
Internal gearing – Roller-bearing slewing ring		150	330.7
Idler (permanent grease filling)	Tribol Terex O&K part no. 2764564	2 x 4.4	2 x 9.7
Track rollers (permanent grease filling)		14 x 14	14 x 30.9
Support rollers (permanent grease filling)		4 x 1.3	4 x 2.9

¹⁶ see "LUBRICANTS" section.

¹⁷ apply a thin layer of hydraulic oil

III.c Oils for travel gearboxes

Ambient temperature	°F	-58	-40	-22	-4	+14	+32	+50	+68	+86	+104	+122
	°C	-50	-40	-30	-20	-10	0	+10	+20	+30	+40	+50
Specification: Mineral oil: DIN 51 517-3: CLP ISO 6743-6: CKC Synthetic oil: DIN 51 517-3: CLP ISO 6743-6: CKC FZG Test > 12	TM Special Gearoil CLP 220 PLUS Terex O&K P/N 2 482 891											
	CLP 220											
	TM Gearoil CLP 220 LT Terex O&K P/N 6 002 885											

8003121

Fig. 3-8:

Centrifuge (optional)

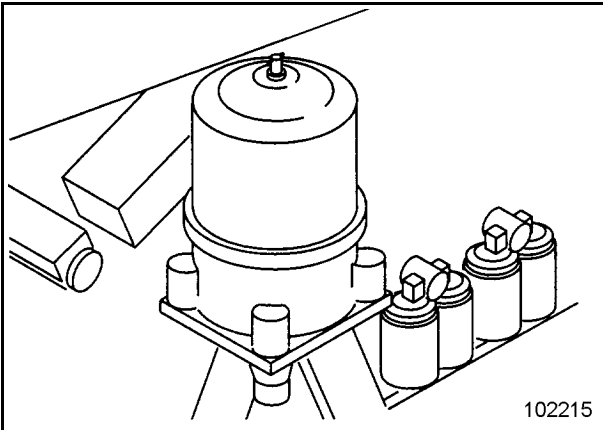
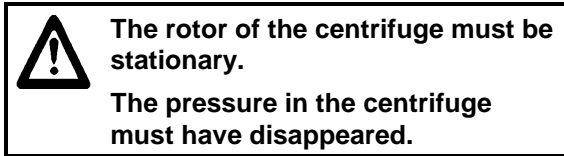

Fig. 3-27:

The centrifuge (Fig. 3-27:) filters out engine oil impurities in the bypass line by centrifugal forces.

Servicing

- Shut off the engines
- Wait 5 minutes



The centrifuge may also be hot.

Wear protective gloves and firm working clothing.

- Loosen clamp (2, Fig. 3-28:) and withdraw housing (1).
- Check housing seal (8) and replace, if required.
- Unscrew knurled nut (3) and draw off rotor cap (4).
- Remove dirt from the rotor cap by tapping lightly against the cap.
- Clean rotor cap (4) and vertical tube (5) thoroughly with white spirit and dry.

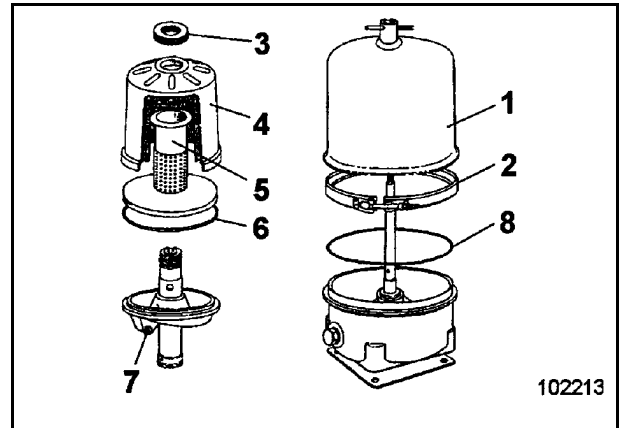
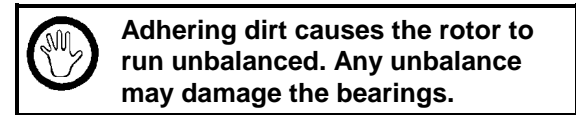
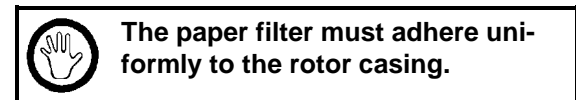

Fig. 3-28:



- Replace seal (6) inserting it slightly smeared with oil.
- Check nozzle (7) for free passage. If necessary, open up nozzle with a wire or with compressed air.
- Place paper filter into the rotor cap.



Thereafter

- Allow engines to run for short while and check centrifuge for tightness and leaks before shutting off the engines.
- Check oil level after abt. 10 minutes and top up, if required.

Venting the fuel system

The fuel tanks are vented with breather valves (3, Fig. 3-46:).

Clean breather valves regularly.

- Remove breather valve, flush with paraffin oil and blow clean with compressed air.

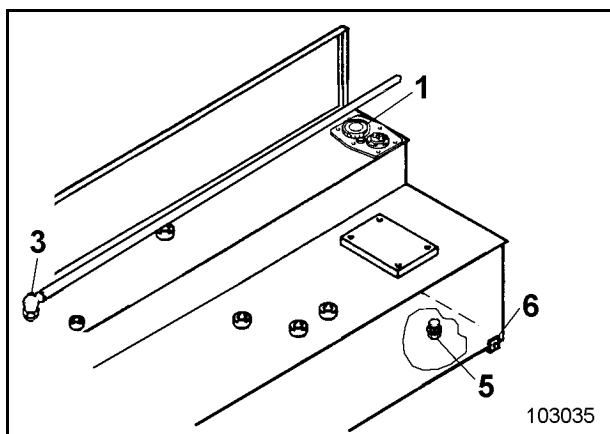

Fig. 3-46:

Cleaning the fuel tanks



Explosion hazard.
Read and observe the "Inspection and servicing. Safety instructions" chapter.

Do not use white spirit, paraffin oil or other solvents.
For flushing and cleaning use diesel fuel.
Avoid skin contact.
Skin contact with diesel fuel may cause skin injury.
Wear firm working clothing.
Wear protective gloves or use a barrier cream.



Fuel must be prevented from penetrating into the soil. Keep fuel for re-use or discard without polluting the environment.

- Use up as much fuel as possible.
- Check how much fuel remains in the tank and place a collecting recipient of sufficient size under the drain plugs of the tanks.
- Loosen drain plug (6) at fuel the tank and drain off fuel.
- Flush tank with diesel fuel.
- Screw automatic drain plug backs (6) in place.

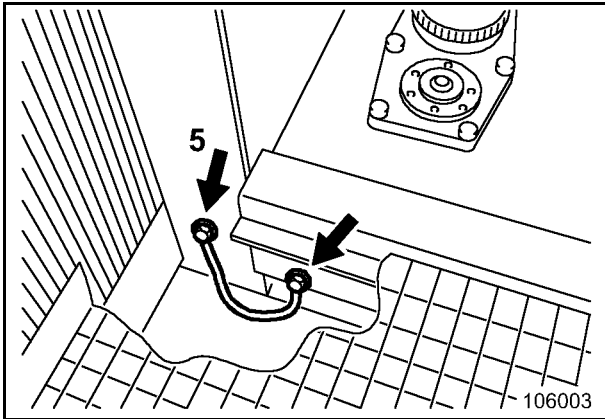

Fig. 3-63:

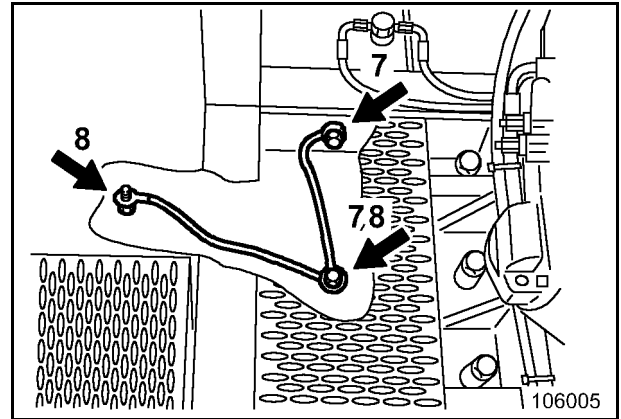

Fig. 3-65:

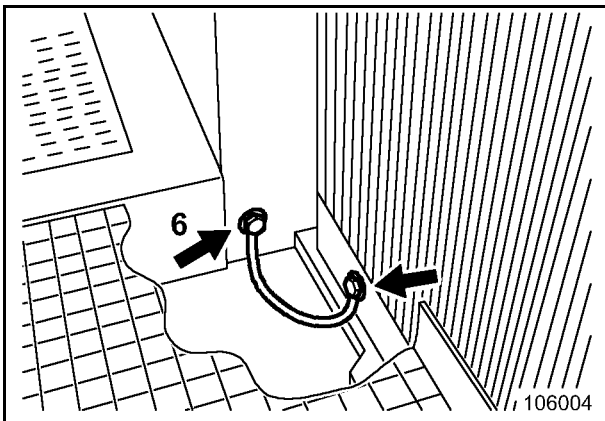

Fig. 3-64:

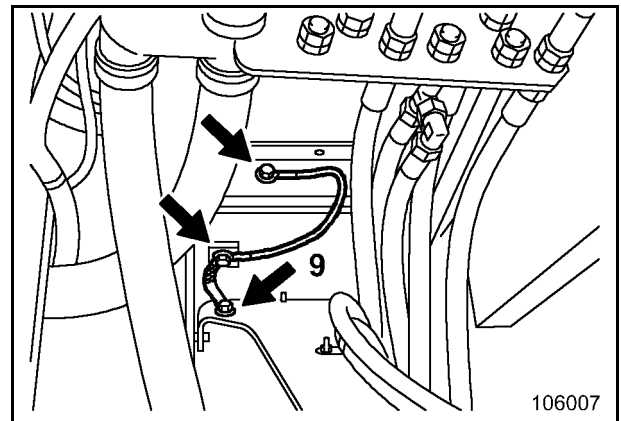
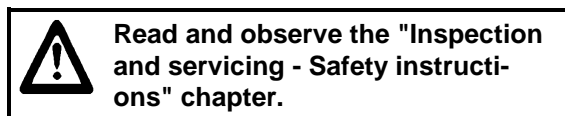

Fig. 3-66:

Filter (control circuit and auxiliary control circuit)

Each of the control circuits is equipped with a high-pressure filter (Fig. 3-85:)



Shut off the engines.

Risk of scalding caused by hot hydraulic oil.

The filter housings may also be hot.

Avoid skin contact.

Skin contact with hydraulic oil may cause skin injury.

Wear protective gloves and firm working clothing.

Replacing the filter element

Change filter element regularly and when the BCS indicates a contamination.

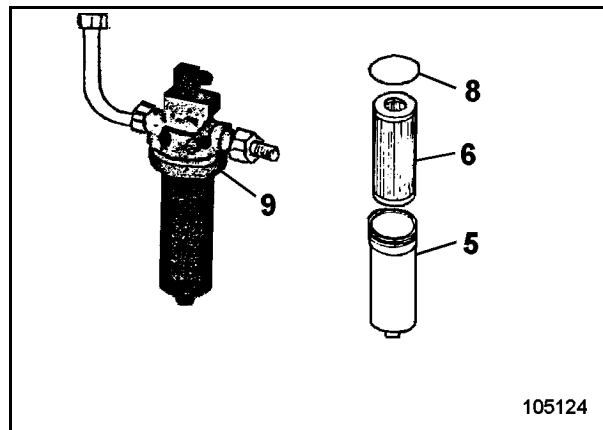

Fig. 3-85:

- Unscrew filter housing (5, Fig. 3-85:).
- Withdraw filter element (6) from filter housing (5).
- Clean filter housing (5) and the sealing face at the filter head (9) with white spirit or paraffin oil.
- Check seals (10 and 14) and replace, if required.
- Insert new filter element into filter housing (5) and refit to the filter head with new, lightly oiled sealing ring (8).
- Check for leaks after putting the filter into operation.

PUMP TRANSFER GEARBOX

7



Read and observe: "Inspection and servicing - Safety instructions."
Shut off the engines
The gearbox housings may be hot, too.
Secure the machine as described in the "Securing the machine" section.
Protect the skin from contact with gearbox oil.
Skin contact with cooling liquid is a potential health hazard.
Wear protective gloves and firm working clothing.

Checking the gearbox oil level / Topping up with oil

Park the machine as described in the "Securing the machine" section.

- Unscrew dipstick (1, Fig. 3-103:) and wipe.
- Insert dipstick (1) fully again and withdraw a second time.
Oil level should lie between the two dipstick markers. Top up with oil if required.
- Screw in dipstick (1) again.

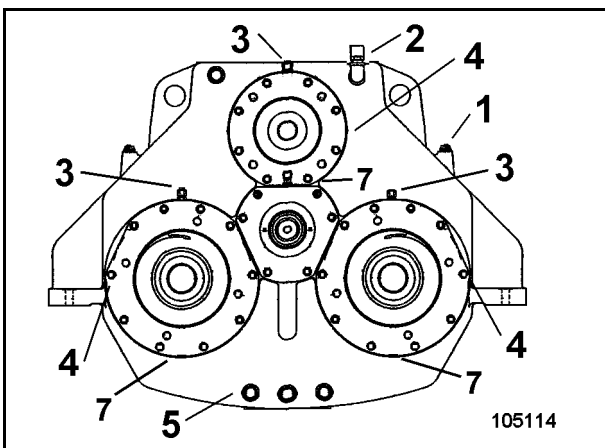

Fig. 3-103:

Pre-chamber

Checking oil level

The oil level in the pre-chambers is visually at the inspection glass (3, Fig. 3-104) in expansion reservoir (1).

The oil level should reach up at least to the middle of the inspection glass (3). Top up with gearbox oil, if required.

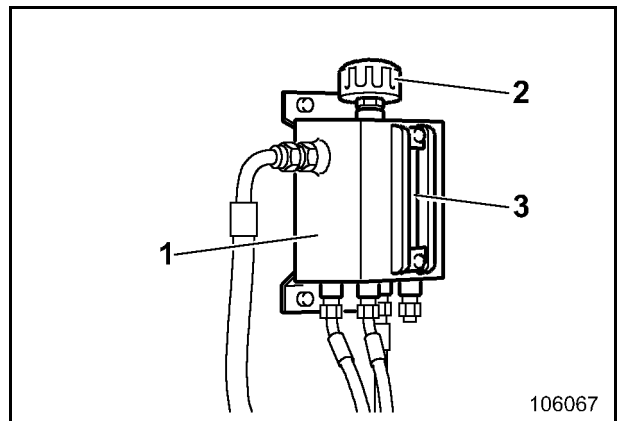

Fig. 3-104

Track roller, Support roller

Inspect all track and support rollers visually for leaks and free movement at regular intervals.

Track roller fastening

Check fastening screws (4 Fig. 3-121:) regularly for tightness:

- Tighten screws with a torque wrench to the prescribed tightening torque (see "Technical Handbook").

Support roller fastening

Check fastening screws (3, Fig. 3-121:) regularly for tightness

Tighten screws with a torque wrench to the prescribed tightening torque (see "Technical Handbook").

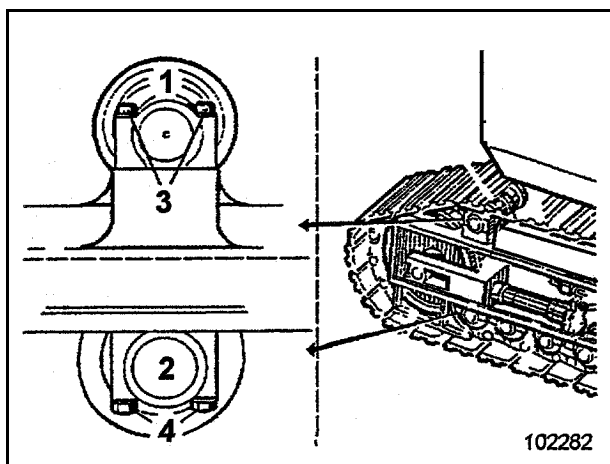
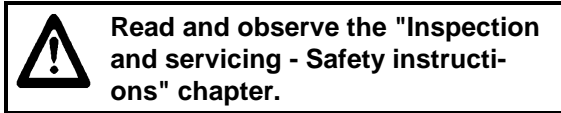

Fig. 3-121:

Oilfilter (hydraulic circuit grease pump))



Shut off the engines.

Risk of scalding caused by hot hydraulic oil.

The filter housings may also be hot.

Avoid skin contact.

Skin contact with hydraulic oil may cause skin injury.

Wear protective gloves and firm working clothing.

For filtering of the hydraulic oil, high pressure filter (11, Fig. 3-139:).is installed in the pumping line.

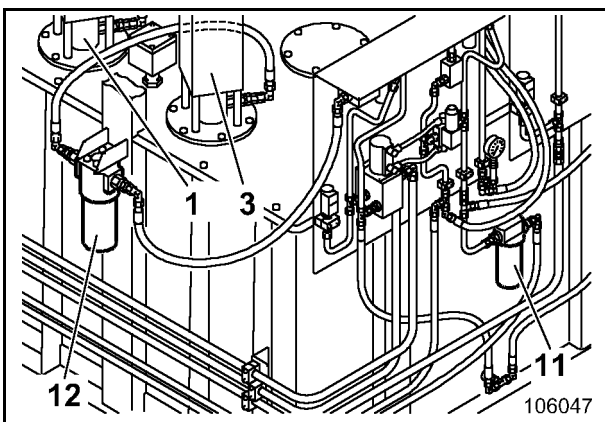

Fig. 3-139:

Replacing the filter element

Change filter element regularly and when the BCS indicates a contamination.

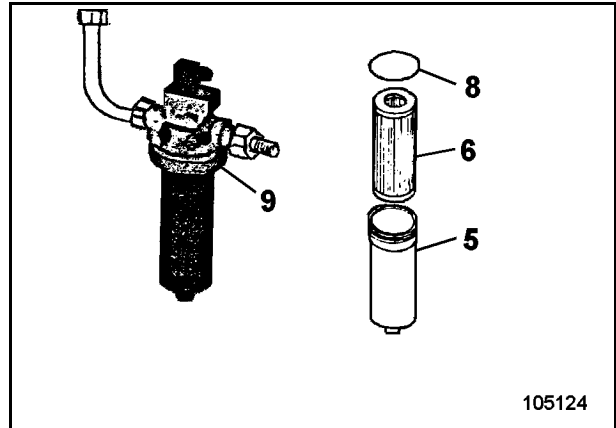

Fig. 3-140:

- Unscrew filter housing (5, Fig. 3-140:).
- Withdraw filter element (6) from filter housing (5).
- Clean filter housing (5) and the sealing face at the filter head (9) with white spirit or paraffin oil.
- Check seals (10 and 14) and replace, if required.
- Insert new filter element into filter housing (5) and refit to the filter head with new, lightly oiled sealing ring (8).
- Check for leaks after putting the filter into operation.



NOTIZEN

A series of horizontal dotted lines spanning the width of the page, intended for handwritten notes.



HYDRAULIC SYSTEM

Repair

Always depressurize the hydraulic system before disconnecting any hydraulic hoses.

Replace damaged or leaking hydraulic hoses by new ones. Use original Terex|O&K spare parts. These parts are specially suitable for the respective function. Do not re-use used hoses.

Dispose of spilt oil and oily wastes without polluting the environment. These wastes must not be allowed to penetrate into the soil.

Hydraulic hoses should be replaced after a service life of 6 years.

Read and observe also the "Inspection and servicing - Safety instructions" chapter.



Working hydraulics – Fault table

Fault		Remedial action	
Working and slewing functions not operational		Check	P
No boom function		Adjust	E
No bucket function		Replace	W
No backhoe function		Top up	A
No stick function		Reduce	S
Working movements too slow		Clean	R
Power loss in working hydraulics		1) Contact the Terex O&K Service	
Uncontrolled working movements			
Cause		Abschnitt	
•	Electronic excavator control not activated/defective	Working	P
•••••	Malfunction of pressure-relief valve		1)
•	Servo system pump defective		1)
•••••	Malfunction of primary / secondary pressure-relief valves		1)
	Engine speed too low		P
	ECO-power switch in 80%-position		P
	Fuel filter contaminated	Fuel filter	P/W
	Insufficient engine power	Engine malfunction	1)
	Hydraulic oil temperature too high (warning lamp lit, PMS fault indicator lamp lit) oil cooler contaminated	Hydraulic oil cooler cleaning	P/R
	Engine coolant temperature too high (warning lamp lit and PMS fault indicator lamp flashing)		1)
	Malfunction of solenoid valves		1)
	Malfunction of control spool		1)
•	Engine coupling defective		

RH 120-E



Hydraulic Mining Excavator

General Data

Operating weight

Face shovel	283 t	312 sht
Backhoe	285 t	314 sht

Engine output SAE J 1995

Caterpillar	1,044 kW	1,400 HP
Cummins	1,008 kW	1,350 HP

Standard bucket capacity

Face shovel (SAE 2:1)	15.0 m ³	19.6 yd ³
Backhoe (SAE 1:1)	15.0 m ³	19.6 yd ³

Features

- ▶ TriPower shovel attachment
- ▶ Independent oil cooling system
- ▶ Spacious walk-through machine house
- ▶ 5-circuit-hydraulic system
- ▶ Electronic-hydraulic servo control
- ▶ Board Control System (BCS)
- ▶ Torque control in closed-loop swing circuit
- ▶ Automatic central lubrication system
- ▶ Xenon working lights

General Dimensions

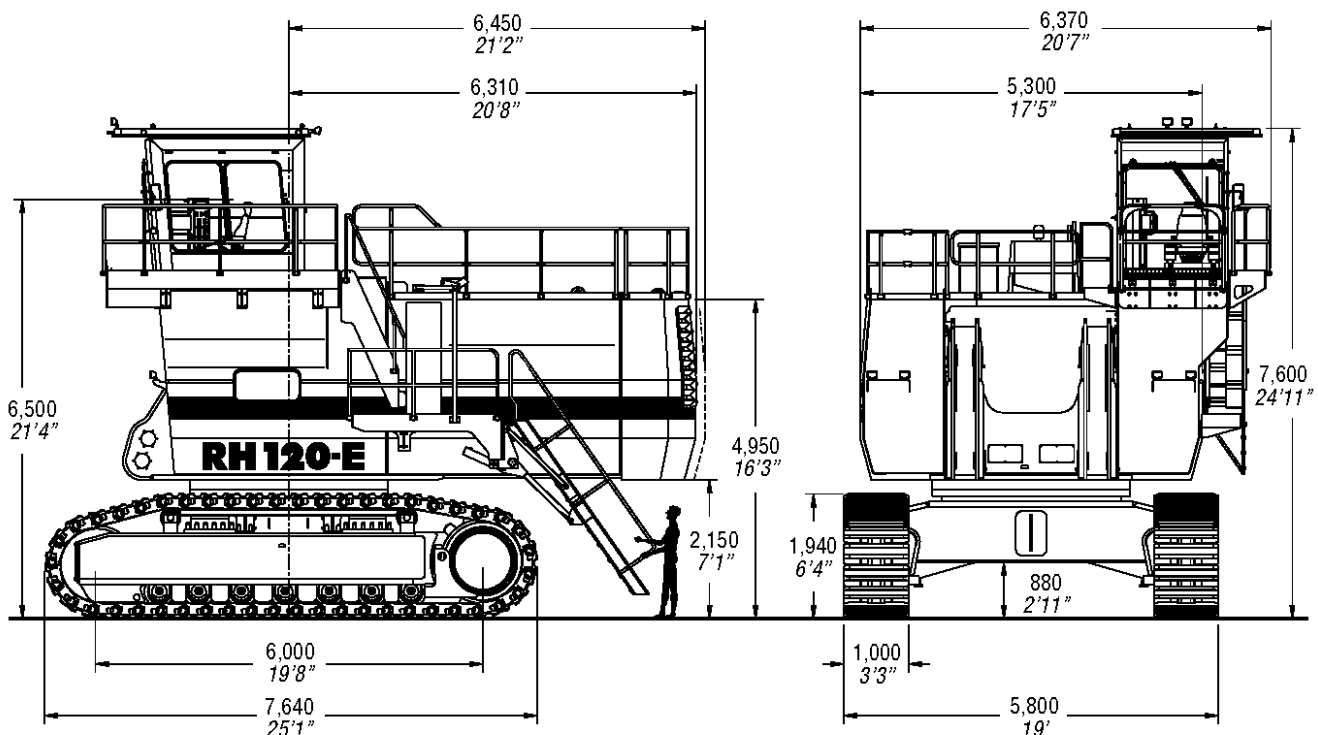

Operating Weight - Shovel

Standard track pads	1,000 mm	3'3"
Operating weight	283,000 kg	623,900 lbs
Ground pressure	21.2 N/cm ²	30.7 psi
Further track pads on request		

Operating Weight - Backhoe

Standard track pads	1,000 mm	3'3"
Operating weight	285,000 kg	628,310 lbs
Ground pressure	21.3 N/cm ²	30.9 psi
Further track pads on request		

CLICK HERE TO **DOWNLOAD** THE COMPLETE MANUAL

- Thank you very much for reading the preview of the manual.
- You can download the complete manual from: www.heydownloads.com by clicking the link below



- Please note: If there is no response to CLICKING the link, please download this PDF first and then click on it.

CLICK HERE TO **DOWNLOAD** THE COMPLETE MANUAL