



Technical Manual

CLICK HERE TO **DOWNLOAD** THE COMPLETE MANUAL

- Thank you very much for reading the preview of the manual.
- You can download the complete manual from: www.heydownloads.com by clicking the link below



- Please note: If there is no response to CLICKING the link, please download this PDF first and then click on it.

CLICK HERE TO **DOWNLOAD** THE COMPLETE MANUAL

 **CAUTION:** Many of the component parts of the 1370W are heavy, bulky items. Extreme caution should be used when lifting these items. Personnel should be certain of the weights of components before attempting to lift them, either manually or with some lifting device. All applicable safety rules should be followed when using cranes or other lifting equipment. Be sure of the load, lifting height and radius, and capacity of the machine before lifting a load. Failure to follow all applicable safety rules when lifting heavy parts can cause serious or fatal injury.

8. Drain the first reduction gearcase.
9. To remove the first reduction gearcase cover:
 - a. Remove the motor shaft end cover bolts and end cover (figure 8). Remove the O-ring from the end cover.
 - b. Remove the bolts securing the bearing retainer, on the coupling end, to the gearcase.
 - c. Remove the intermediate shaft end cover bolts and remove the end cover from the gearcase (figure 9). Remove the O-ring from the cover.
 - d. Remove the bolts securing the inner seal retainer to the gearcase.
 - e. Remove the rod bolts and dowel bolts securing the gearcase cover to the gearcase. Remove the gearcase cover.
10. With the overhead crane, lift the motor input shaft from the gearcase.
11. To disassemble the motor input shaft (figure 8), remove the half coupling and key from the shaft. Remove the bearing spacer.
12. Slide the bearing retainer assembly from the shaft. Remove the O-ring, seal retainer and oil seal from the retainer.
13. Remove the bearing retainer from the other end of the shaft. Remove the bearings from both ends of the shaft.

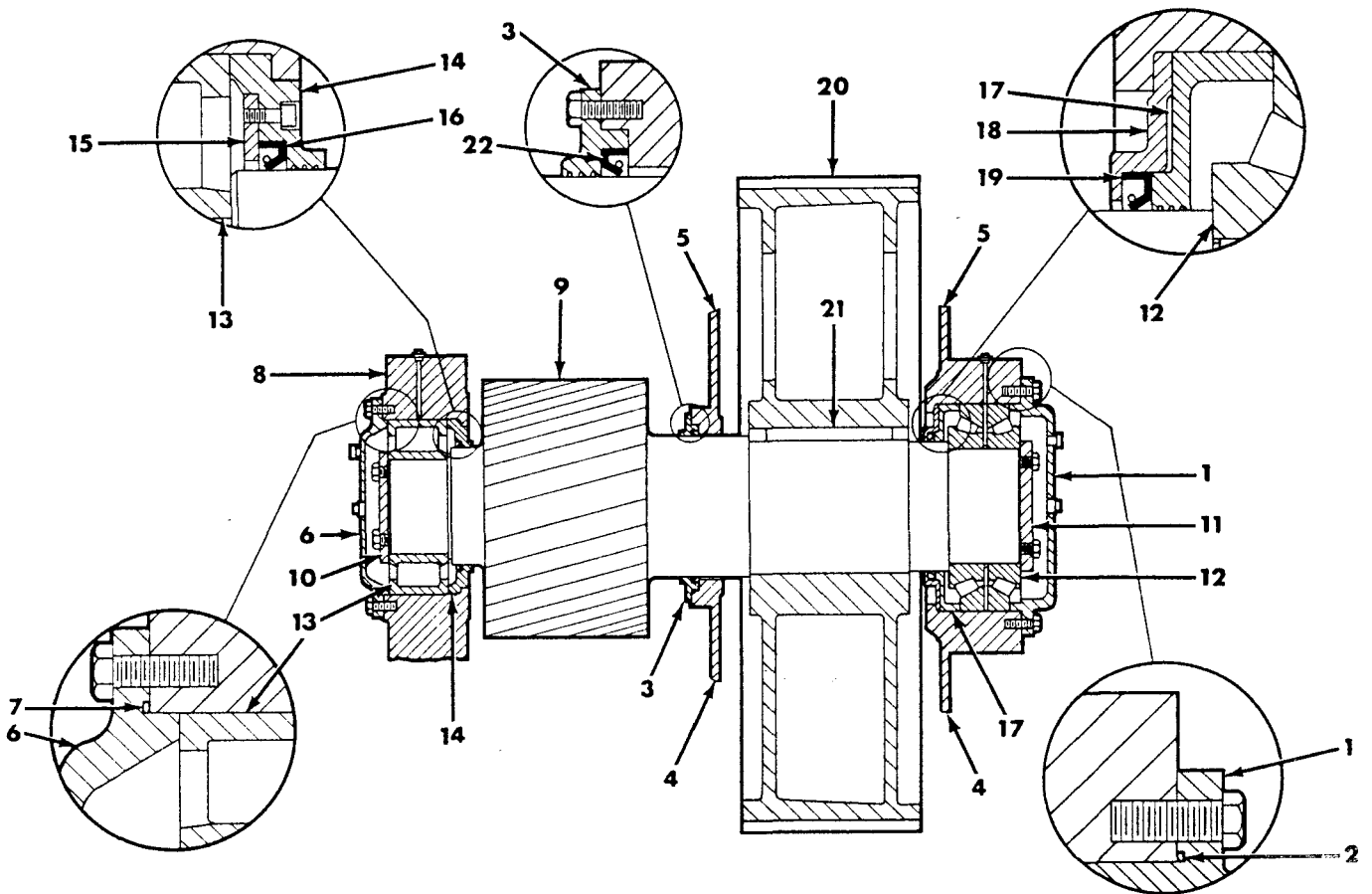

1. END COVER
2. END COVER O-RING
3. INNER SEAL RETAINER
4. GEARCASE COVER
5. GEARCASE COVER
6. END COVER
7. END COVER O-RING
8. BEARING CAP

9. INTERMEDIATE SHAFT
10. BEARING RETAINER
11. BEARING RETAINER
12. BEARING
13. BEARING
14. INNER RETAINER
15. SEAL RETAINER
16. OIL SEAL

17. INNER RETAINER
18. SEAL RETAINER
19. OIL SEAL
20. INTERMEDIATE GEAR
21. GEAR KEY
22. RETAINER OIL SEAL

HOIST AND DRAG INTERMEDIATE SHAFT

FIGURE 9

1. BEARING CARRIER
2. FIELD ASSEMBLY FIXTURE
3. LOWER BEARING
4. VERTICAL SHAFT
5. FIELD ASSEMBLY SPACER
6. BEARING SLEEVE
7. PINION RETAINER
8. LOWER RETAINER
9. RETAINER GASKET

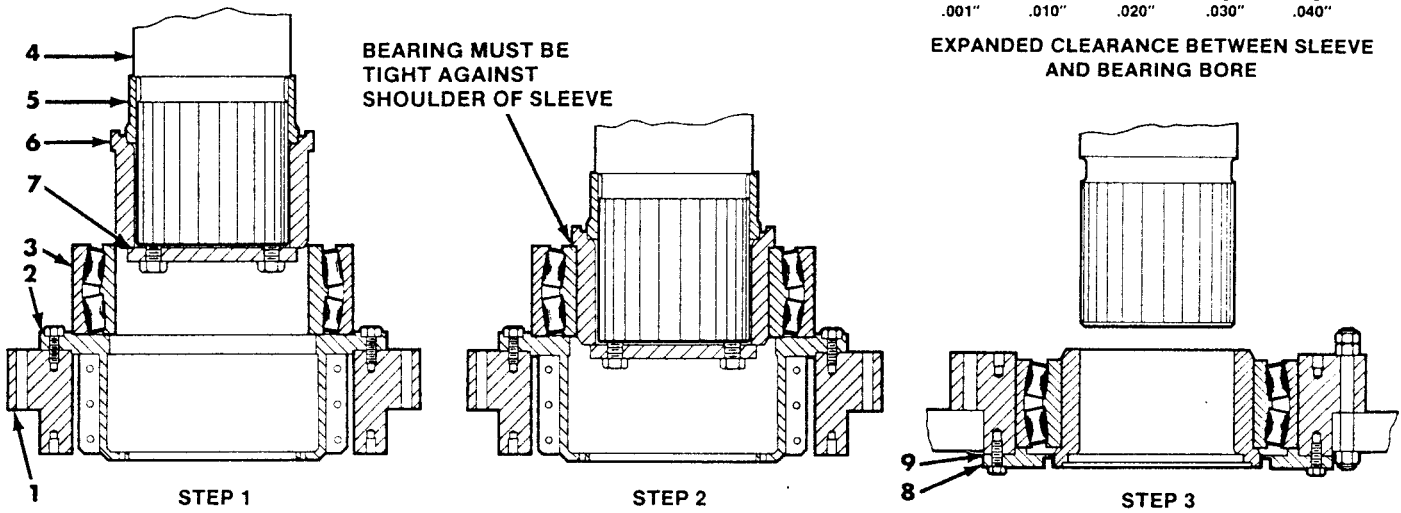
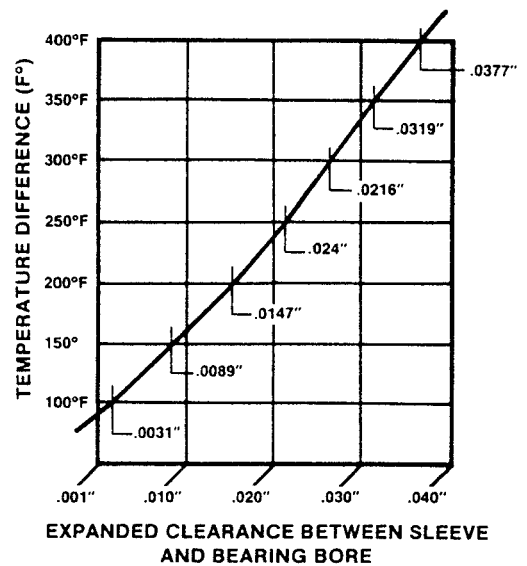

LOWER BEARING ASSEMBLY

FIGURE 18

- i. Install the bearing lower retainer and gasket on the bearing carrier. Lower the shaft until the bearing rests on the retainer. Remove the pinion retainer and lift the shaft high enough to remove the field assembly spacer.
 - j. Reinstall the remaining retainers, seals and gaskets on the lower bearing (figure 12). When installing the bearing upper retainer, check the gap between the retainer and the carrier. If the gap exceeds .055 inches add an additional gasket.
3. Vertical Shaft (figure 12)
- a. When replacing the vertical shaft, use sufficient shims at the top of the shaft to obtain 1/4 inch pinion to rack overlap.
 - b. If the shaft safety bolt was removed, install it at this time.
 - c. When installing the shaft pinion, torque the bolts until the belleville washers are

flat, then back off 1/4 turn. Lockwire the bolts.

4. Intermediate Shafts (figure 12)

- a. The lower bearing inner race is interference fit and must be heated in an oil bath to 250°F prior to assembly.
- b. Check the fit of gear key to gear and shaft. The gear is interference fit and the bore must be heated to 250°F prior to installation. For the "Y" shaft, be sure the spacer is installed before installing the gear.
- c. The upper bearing is interference fit to the shaft. Assemble the bearing spacer (and gear spacer on "Z" shaft) on the shaft. Assemble the upper bearing to the bearing carrier and assemble the seal and seal retainer to the carrier. Be sure the seal lip is facing toward the bearing. Cool the shaft upper end with dry ice prior to installing bearing assembly.

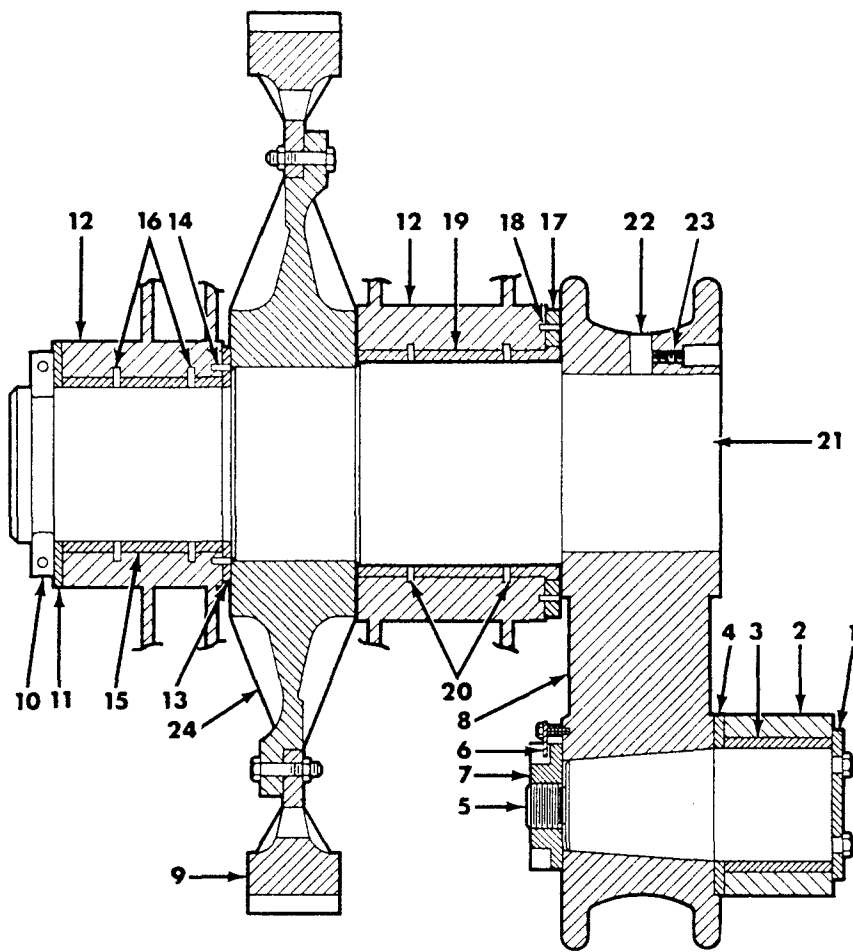

- 1. RETAINER
- 2. CAM GUIDE ROLLER
- 3. ROLLER BUSHING
- 4. THRUST WASHER
- 5. ROLLER PIN
- 6. NUT LOCK BAR
- 7. ROLLER PIN NUT
- 8. CAM
- 9. GEAR
- 10. SHAFT CLAMP COLLAR
- 11. THRUST WASHER
- 12. GIRDER
- 13. THRUST WASHER
- 14. DOWEL
- 15. BUSHING
- 16. DOWEL
- 17. THRUST WASHER
- 18. DOWEL
- 19. BUSHING
- 20. DOWEL
- 21. CAM SHAFT
- 22. CAM RETAINING PIN
- 23. PIN SET SCREW
- 24. GEAR SPIDER

CAM SHAFT
FIGURE 29

align, the bushing may be rotated 15° and new holes drilled. The bushings must be shrunk fit to the hubs and bearing sleeve. Be sure all dowels are flush with or slightly below the face of the bushings. Coat the bushing bores with a film of Molykote® Type "G".

2. On the front gear train, the shaft may be inserted and then the gear installed, but on the rear gear train, the gear must be positioned and cribbed so that the bore of the gear aligns with bushing bores prior to installing the shaft. Also, the gear thrust washer must be supported in place prior to positioning the gear.

c. Second Intermediate Shaft (figure 27)

1. If an outside crane is available for assembly, the second intermediate gear can be assembled and mounted to the shaft prior to installing the shaft. If

not, then the gear rim will have to be installed after the shaft has been installed.

2. The gib keys should be checked as to fit to the shaft and the gear. There should be at least 80% contact on all surfaces.
3. When installing the bushings in the girder or pedestal and the bearing sleeve, new dowel holes will have to be drilled. Since the dowels fit in the end of the bushings, check for 10,020 minutes running clearance. If necessary, scrape high points.
4. When installing the gear or spider on the shaft, insert the gib keys but do not drive them tight. The keys are driven tight only after the gear and shaft are completely assembled in the pedestal or girder. In the case of the second intermediate shaft pedestal mounted, the keys cannot be driven in until the

ADJUSTMENT

As the brake linings wear, the brake will have to be adjusted to maintain proper braking. After several adjustments or as the thickness of the shoe lining approaches 5/16 inch, the linings will have to be replaced. The brake is adjusted as follows:

1. When the spring length reaches A-max loosen the jam nut and tighten the special nut until the spring length reaches A-min dimension.
2. Also adjust the adjusting screw to shorten the B dimension 3/8 inch each time the spring is readjusted. This will prevent the cylinder from bottoming out and possibly preventing the brake from setting.
3. Release brake, check for equal clearance of lining to drum, and readjust jaw set screws for 1/64 inch clearance.

DRAG ROPE SUPPORT

Periodically inspect the base and shaft mountings of the drag rope support (figure 47). Check for cracks in the supports as well as the dirt deflectors and repair weld as required. Lubricate all grooves and bearings of the sheaves to insure smooth rotation and sliding movement. If it is necessary to

replace the bearings of a sheave, use the following procedure.

1. Secure the drag rope so that it does not rest on the sheave. Securely crib under the sheave.
2. Remove the sheave shaft retainer and pull the shaft from the supports and sheave.
3. Remove the sheaves from the cribbing and dismantle as follows:
 - a. Remove the bearing retainers from each end of the sheave. Remove the wipers from the retainers.
 - b. Remove the bearings from the sheave. The bearings are interference fit to the sheave and will require a bearing puller for removal.
4. Reassemble the sheave by pressing the bearings into the sheave. Be sure the bearings are tight against the shoulder in the sheave. Install new wipers in the retainers and bolt the retainers to the sheave.
5. Check the sheave shaft and clean up all nicks or burrs with a fine tooth file.
6. Position the sheave on the cribbing and install the shaft. Install the shaft retainer. Release the drag rope.

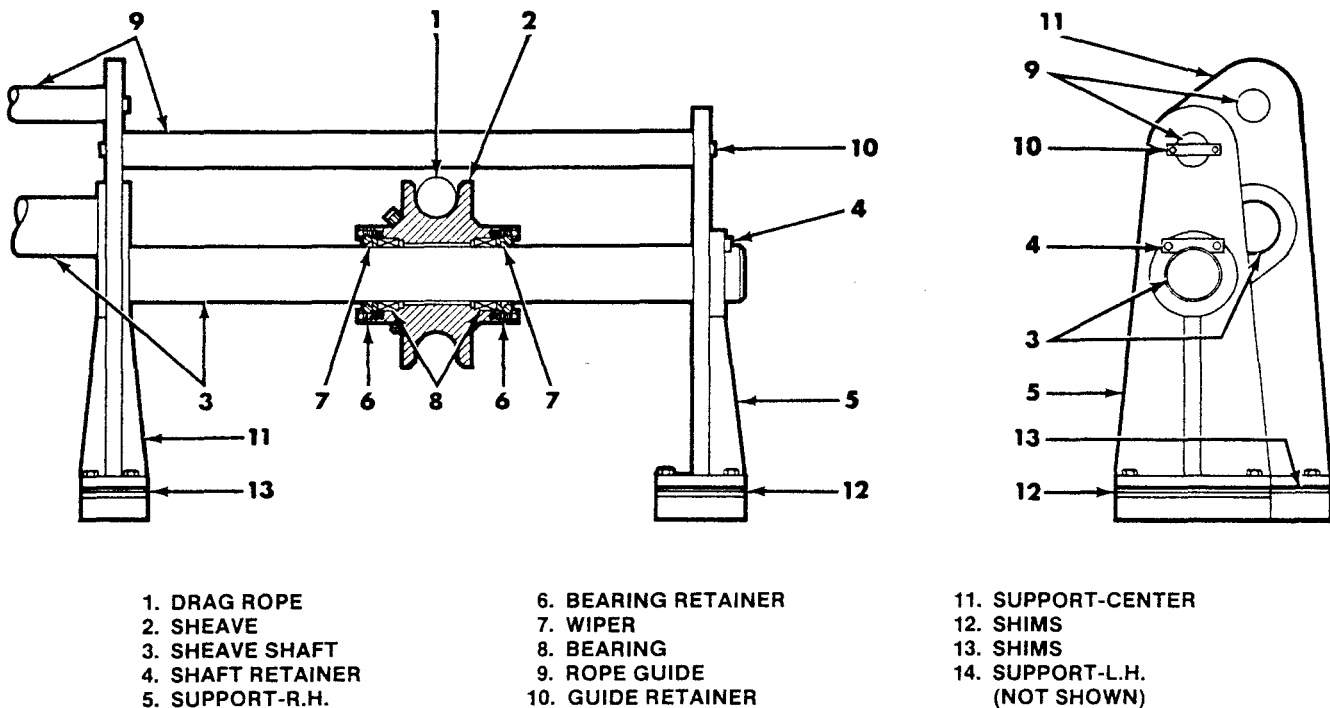

DRAG ROPE SUPPORT

FIGURE 47

2. Remove the lock nut and lock washer from the opposite end of the screw.
3. Remove the bolts securing the end plate to the guide and remove the end plate. Separate the labyrinth seal and bearing from the end plate.
4. Remove the nut and lock washer from the coupling end of the screw.
5. Slide the screw and roller unit from the guide. Separate the screw from the roller unit. Separate the screw nut and flange from the roller unit. Remove the cotter pins and remove the washers and rollers from the roller unit.
6. Remove the capscrews securing the bearing housing to the guide and remove the bearing housing from the guide. Separate the labyrinth seal, bearing carrier and bearing from the housing.

7. Inspect all parts and repair or replace all damaged or worn parts.
8. Reassemble in reverse of disassembly and lubricate the screw and bearings.

NOTE: When reassembling the unit, tighten the lock nuts only enough to remove all end play. Do not bind the bearings.

WINDSHIELD WIPER

The windshield wiper (figure 57) on the front window of the cab has an adjustable crank which will vary the horizontal length of travel of the wiper. Make sure the crank is set so the wiper will swing freely across the window without interference with the window frame. Check the wiper blades, linkage and spring for proper operating condition.

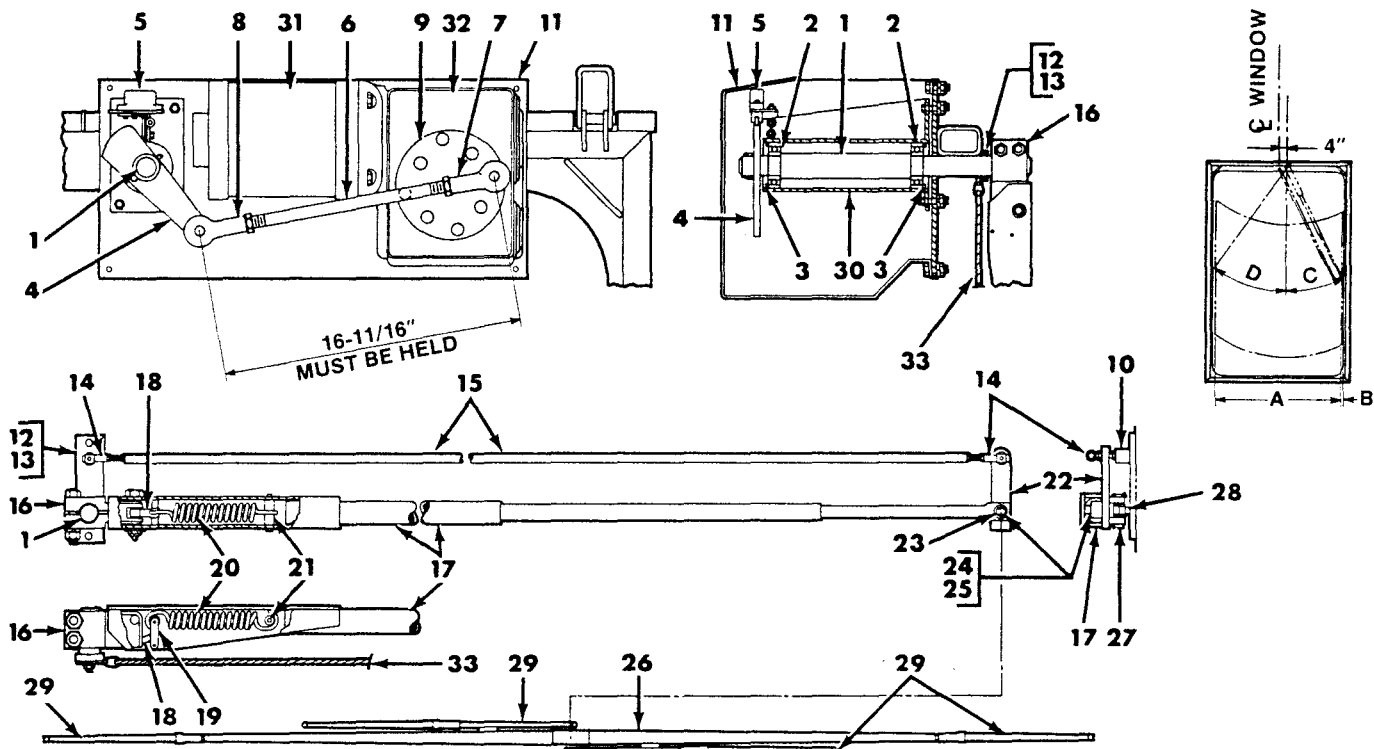

- | | | |
|-------------------|--------------------|---------------------|
| 1. SHAFT | 12. SEAL SUPPORT | 23. ARM TIP BUSHING |
| 2. BEARING | 13. SEAL PACKING | 24. ARM TIP WASHER |
| 3. RETAINING RING | 14. BALL JOINT | 25. ARM TIP SCREW |
| 4. CAM LEVER | 15. PANTOGRAPH ARM | 26. WIPER HOLDER |
| 5. LIMIT SWITCH | 16. MOUNTING HUB | 27. HOLDER PIN |
| 6. CONNECTING ROD | 17. WIPER ARM | 28. SUPPORT SHIM |
| 7. ROD END | 18. LINK | 29. WIPER BLADE |
| 8. ROD END | 19. LINK | 30. HOUSING |
| 9. CRANK | 20. SPRING | 31. MOTOR |
| 10. ROD END STAND | 21. SPRING ANCHOR | 32. REDUCER |
| 11. GUARD | 22. YOKE | 33. WINDOW |

CRANK ARM RADIUS	A	B	C*	D*
2-3/8	55-7/8	1-7/8	26.3°	36.3°
2-7/16	57-3/8	1-1/8	27.2°	37.3°
2-1/2	58-7/8	3/8	28.1°	38.3°
2-9/16	60-5/8	-5/8	29.0°	39.3°

* WITH WIPER PATH CENTERED

WINDSHIELD WIPER

FIGURE 57

CLICK HERE TO **DOWNLOAD** THE COMPLETE MANUAL

- Thank you very much for reading the preview of the manual.
- You can download the complete manual from: www.heydownloads.com by clicking the link below



- Please note: If there is no response to CLICKING the link, please download this PDF first and then click on it.

CLICK HERE TO **DOWNLOAD** THE COMPLETE MANUAL

- | | | |
|--|--|---|
| <ol style="list-style-type: none"> 1. INTAKE AIR FILTER 2. ANTI-FREEZER 3. AIR COMPRESSOR 4. AIR COMPRESSOR MOTOR 5. INTERCOOLER 6. CENTRIFUGAL UNLOADER 7. GATE VALVE 1-1/4" 8. CHECK VALVE 9. RADIATOR (ON SOME MACHINES) 10. AIR TANK 11. DRAIN VALVE 12. AIR PRESSURE GAUGE 13. RELIEF VALVE (SET AT 165 PSI) 14. DRAIN COCK 1/4" 15. PRESSURE SWITCH
(START COMPR. AT 145 PSI)
(STOP COMPR. AT 165 PSI) 16. FILTER 17. REGULATOR AND GAUGE
(SET AT 130 PSI) 18. LUBRICATOR 19. RELIEF VALVE (SET AT 135 PSI) 20. SOLENOID VALVE | <ol style="list-style-type: none"> 21. GLOBE VALVE 3/8" 22. HORN 23. GLOBE VALVE 24. PRESSURE SWITCH
(OPEN CIRCUIT AT 95 PSI)
(CLOSE CIRCUIT AT 110 PSI) 25. FILTER 1-1/4" 26. REGULATOR & GAUGE
(SET AT 70 TO 90 PSI) 27. LUBRICATOR 1-1/4" 28. SOLENOID OPERATED FLOW
CONTROL VALVE 29. THREE WAY BALL VALVE 30. PROPEL TRANSFER SWITCH
AIR CYLINDER 31. SHUT-OFF COCK 1/2" 32. GATE VALVE 1/2" 33. LUBRICATOR 1/2" 34. SOLENOID VALVE 35. FILTER 1/2" 36. QUICK RELEASE VALVE 1" 37. HOIST BRAKE AIR CYLINDER 38. DRAG BRAKE AIR CYLINDER | <ol style="list-style-type: none"> 39. SWING BRAKE AIR CYLINDER 40. DRAIN COCK 1/2" 41. QUICK RELEASE VALVE 3/4" 42. PROPEL BRAKE AIR CYLINDER 43. LUBRICATOR 1" 44. WINCH 45. FILTER 1-1/4" 46. LUBRICATOR 1" 47. GATE VALVE 1" 48. FAIRLEAD RESTRICTION BRAKE 49. GLOBE VALVE 1/2" 50. AIR DRYER 51. AIR PRESSURE GAUGE
(SET AT 95 PSI) 52. RELIEF VALVE
(SET AT 95 PSI) 53. PRESSURE SWITCH
(OPEN CIRCUIT AT 55 PSI)
(CLOSE CIRCUIT AT 70 PSI) 54. AIR PRESSURE GAUGE 55. RELIEF VALVE (SET AT 35 PSI) 56. PRESSURE SWITCH
(CLOSE CIRCUIT AT 15 PSI) |
|--|--|---|

TYPICAL AIR SCHEMATIC

FIGURE 81 (cont.)

AIR TANK

Check the air tank for damage. Check all the connections to the air tank. Tighten if necessary.

AIR LINE LUBRICATOR

Daily check that the lubricator is full of oil and operating correctly. Add oil if required.

AIR LINE FILTER

Daily check the filter for accumulation of moisture and drain any moisture by opening the drain cock in the bottom of the bowl. A visible coating of dirt or condensation on the filter cone or an excessive pressure drop indicates the filter cone needs cleaning.

AIR LINE REGULATOR

Daily check the regulator for reduced pressure, unsteady pressure or deviations in excess of normally observed setting. If any of these conditions exist the filter could be dirty or the shutoff valve could be partially closed. Check the filter and valve. If this does not solve the problem repair or replace the regulator.

ANTI-FREEZER — ALCOHOL TYPE (Optional)

Before freezing weather sets in the wicks of the anti-freezer should be checked and cleaned or replaced as required. During freezing weather keep the level of the alcohol at a maximum. Check level at dipstick and fill as required using dipstick hole. The container holds about one quart. Before filling the anti-freezer stop the compressor.



CAUTION: When filling the anti-freezer with alcohol no open flame or smoking is allowed in the area. Alcohol is highly flammable and if ignited could cause serious burns.

The rate of evaporation is changed by raising or lowering the control rod in the top of the anti-freezer. Lowering the rod increases the rate of evaporation, raising the rod will decrease it. Completely removing the rod will stop the evaporation.

SOLENOID VALVES

The brakes and air horn of the air system of the model 1370W Dragline are controlled by electro-mechanical solenoid valves.

The solenoid valves should be checked daily for correct operation and for air leaks.

PRESSURE SWITCHES

There are eight pressure switches located in the air system. These switches should be checked regularly to see that they are operating correctly. If they do not function properly readjust them or have them replaced by an electrician.

The pressure switch and their correct settings are as follows:

1. AIR COMPRESSOR START-STOP SWITCH.
The switch should close and the compressor start when the air pressure in the air tank drops to 145 psi or below. The switch should open and shut off the air compressor when the air tank reaches 160 psi.

ANTI-FREEZER

Clean the wicks (figure 92) with a nonflammable solvent before freezing weather sets in. During freezing weather keep the level of the alcohol at a maximum. The chamber holds about one quart. Before filling the Anti-Freezer, vent the line for the pressure line type. Stop the compressor for the atmospheric type.

The wick carries the alcohol by capillary action into the air passage where it evaporates into the airstream. The alcohol vapor is then distributed to all parts of the system.

The rate of evaporation is changed in the atmospheric type by raising or lowering the control rod in the top of the Anti-Freezer. Lowering the control rod increases the rate of evaporation. With the control rod completely removed, the evaporation stops.

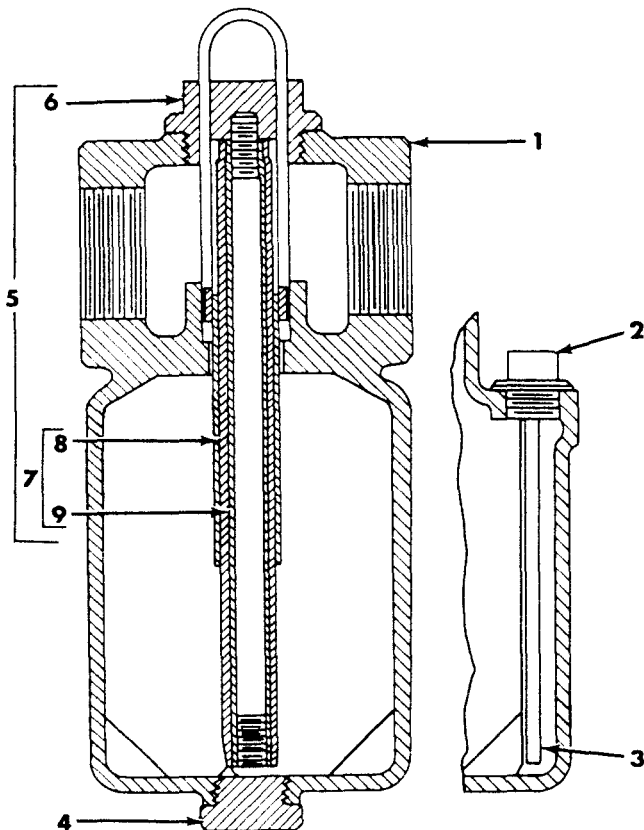

1. BODY
2. CAP NUT
3. CONTROL ROD
4. CAP NUT
5. SUPPORT & SLEEVE ASSEMBLY
6. ADJUSTING SLEEVE
7. WICK SUPPORT
8. OUTER WICK
9. INNER WICK

ANTI-FREEZER

FIGURE 92

AIR REGULATOR

Adjusting to the desired downstream pressure can be done only with live pressure applied to the regulator (figure 93).

CAUTION: Before turning on the air supply, turn the adjusting screw counterclockwise until compression is released from the pressure spring.

The regulator then acts as a shut-off valve. Turn on air pressure and adjust to the desired downstream pressure by turning the adjusting screw clockwise. This allows pressure to slowly build up which prevents any unexpected operation of devices in the line. Be sure all controls are in off or neutral position before opening air regulator.

To increase regulator pressure, turn the adjusting screw clockwise. Adjustment can be made with or without air flowing. Make the adjustment to the required pressure under typical operating conditions. When the desired setting has been reached, securely tighten the locknut.

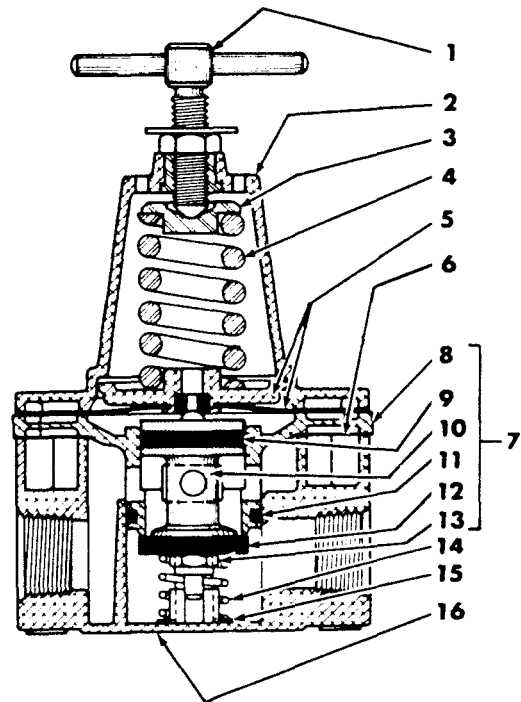

- | | |
|--------------------|-----------------------|
| 1. ADJUSTING SCREW | 9. PISTON SEAL |
| 2. BONNET | 10. PISTON ASSEMBLY |
| 3. SPRING SEAT | 11. CARTRIDGE O-RING |
| 4. CONTROL SPRING | 12. POPPET |
| 5. DIAPHRAGM | 13. LOCKNUT |
| 6. GASKET | 14. COMPENSATING RING |
| 7. CARTRIDGE ASSY. | 15. GAUGE PORT SHIELD |
| 8. CARTRIDGE | 16. BODY |

AIR REGULATOR

FIGURE 93

The SYSTEM-B also serves as a control and pumping station for systems C, E, F and G.

SYSTEM-C

This system lubricates the house roller bushings. It is a satellite of SYSTEM-B and is semi-automatic. The system should be activated semi-annually and the injectors set at maximum delivery.

SYSTEM-D

This system will lubricate the following bearings of the hoist, drag, swing and propel machinery.

1. Hoist intermediate shaft bearings.
2. Hoist drum shaft bearings.
3. Drag intermediate shaft bearings.
4. Drag drum shaft bearings.
5. Swing motor pinion shaft upper bearings.
6. Swing intermediate shaft upper bearings.
7. Swing vertical shaft lower bearings.
8. Propel motor input shaft seals.
9. Propel 1st intermediate shaft bearings.

This system has one control panel and pump station. The control panel has two electric timers to control frequency, one for the hoist, drag and swing machinery and one for the propel machinery. For the hoist, drag and swing machinery the system will be activated once every 4 hours. The injectors should be set for maximum delivery.

For the propel machinery when activated, the system will pre-lube the bearings before start of the walking cycle and then once every four hours during propelling. The injectors should be set for maximum delivery.

SYSTEM-E

This system will lubricate the following sheave and link bushings in the mast head.

1. Boom hoist sheave bushings.
2. Structural strand link bushings.
3. Mast head cross tie.
4. Intermediate structural strand anchor lug bushings.

This system is connected to the control panel and pumping station of SYSTEM-B and the frequency

of lubrication is regulated by the timer of SYSTEM-B. The injectors should be set for maximum delivery for the bushings.

SYSTEM-F

This system will lubricate the following bushings, bearings and thrust washers at the boom point.

1. Boom point sheave bearings.
2. Swivel trunnion bushings.
3. Swivel trunnion thrust washers.

This system is connected to the control panel and pumping station of SYSTEM-B and the frequency of lubrication is regulated by the timer of SYSTEM-B. The injectors should be set for maximum delivery for bushings and thrust washers and 1/2 maximum delivery for bearings.

SYSTEM-G

This system will lubricate the following bushings in the A-frame head.

1. Boom hoist sheave bushings.
2. Structural strand link bushings.
3. A-frame rear leg pin.

This system is connected to the control panel and pumping station of SYSTEM-B and the frequency of lubrication is regulated by the timer of SYSTEM-B. The injectors for the bushings should be set for maximum delivery.

SYSTEM-H

This system is a gear spray system for the following gear reductions of the hoist, drag, swing and propel machinery.

1. Hoist drum gear and pinions (2nd reduction).
2. Drag drum gear and pinions (2nd reduction).
3. Swing pinions and rack (3rd reduction).
4. Cam gear and pinions (4th reduction).
5. Propel (3rd reduction).
6. Propel (2nd reduction).

This system will have one control panel and pumping station. An electric timer will activate the system so it will spray the gear at predetermined intervals of time and only when the machinery is in motion.

PROBLEM	CAUSE	CORRECTIVE ACTION
AIR SYSTEM – AIR COMPRESSOR (continued)		
	b. Head valves not seating.	b. Reseat or replace valves.
	c. Blown head gasket.	c. Replace. (Remove all traces of old gaskets.)
	d. Restriction in head, coils, or check valve.	d. Remove and clean.
	e. Lack of oil.	e. Maintain correct oil level. Be sure oil feeder rings turn freely.
	f. Dirt in coil and cylinder fins. Poor cooling air circulation.	f. Clean.
4. Noisy operation.	a. Loose external parts.	a. Tighten only loose parts.
	b. Pulley striking coils.	b. Be sure pulley is located on shaft correctly and is tight. Bend coils to clear.
	c. Foreign matter such as carbon, metal, chips, etc. on pistons striking head at top of stroke.	c. Remove head and clean.
	d. Retainer or seat not tightened flush with head and allowing piston to strike it.	d. Remove head and tighten.
	e. Piston extends above cylinder at top of stroke.	e. Remove cylinder and add base gasket (not head gasket).
	f. End play in crankshaft.	f. Remove end cover, take out one end cover gasket or shim and replace. Do not remove too many gaskets or binding may result.
	g. Loose or worn internal parts (pistons, connecting rods, wrist pins, insert bearings).	g. Overhaul pump.
5. Slow pumping.	a. Clogged filter element	a. Clean.
	b. Leaks in air line valves or fittings.	b. Replace or tighten threaded parts.
	c. Compressor too small.	c. Add to compressor capacity.
	d. Leaky head valves.	d. Reseat or replace valves.
6. Excessive oil consumption.	Worn or inferior grade of oil.	Use correct oil.

SHAFT DIAMETER	PINION OR COUPLING		PINION ADVANCE	EST. TEMP. DIFFERENCE PINION		COUPLING ADVANCE	EST. TEMP. DIFFERENCE COUPLING	
	INCHES	D INCHES		X INCHES	INCHES		DEG. C	DEG. F
1.750	1.7435	3.00	.011-.014	70	157	.010-.015	68	155
2.000	1.9935	3.50	.013-.018	70	157	.011-.016	63	145
2.500	2.4935	4.00	.017-.022	70	157	.013-.018	54	130
3.000	2.9935	4.50	.020-.025	70	157	.015-.020	49	120
3.250	3.2435	4.50	.027-.032	80	177	.016-.021	46	115
3.625	3.6185	5.00	.037-.045	95	202	.017-.025	42	107
4.250	4.2435	5.00	.045-.055	100	212	.019-.027	38	100
4.625	4.6185	5.50	.055-.065	115	242	.021-.029	38	100
5.000	4.9935	6.00	.065-.075	125	257	.022-.030	37	98
5.875	5.8685	6.75	.070-.080	120	247	.027-.037	37	98
6.250	6.2435	7.25	.075-.085	120	247	.028-.038	35	95
7.000	6.9935	9.25	.080-.090	120	247	.031-.041	35	95

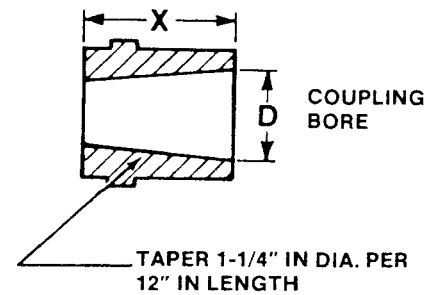
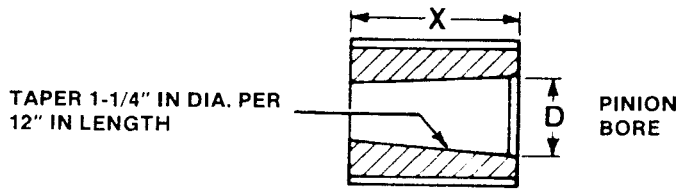

TABLE A1

B.E. Steel Specification SD-	STANDARD MACHINES			COLD WEATHER MACHINES			CASTINGS ALL MACHINES	
	3116	3155	3156	3116	3155	3156		SD-
BASE Bottom Plate All Other Plates	X	X		X	X		BASE Center Pintle	3510B
REVOLVING FRAME Walking Girder Bottom Plate		X				X	REVOLVING FRAME Lift Hook Support Lugs All Other Castings	3520B 3510B
Outer Cam Girder Vertical Exposed Plate	X					X		
Cam Girder Top Plate Outside Machinery House (80 foot Base Machine Only)	X					X	WALKING EQUIPMENT Walking Equipment Guides Walking Equipment Frames Cam Pin Ball Links Sliding Shoe	3520F 3510B 3520BF 3520G 3526BZ
Front Girder Fairlead Support Vertical Plates	X					X		
Vertical Attachment Plates For A-Frame Back Legs	X					X		
All Other Plates	X			X				
A-FRAME Back Legs Front Legs	X	X		X		X	A-FRAME All Castings	3510B
SHOES Bottom Plate All Other Plates	X	X		X	X		SHOES All Castings	3510C
BOOM AND MAST Foot — Thick Plates Foot — All Other Plates Point — All Plates Boom Point Swivel Suspension Links	X	X X X	X	X	X X	X X	BOOM AND MAST All Castings	3510B
SHIELDED METAL ARC WELDING ELECTRODE	STEEL SD 3116 SD 3155 SD 3156			ELECTRODE E7018 E7018 E8018-C1			STEEL SD 3510 SD 3520 SD 3526	ELECTRODE E7018 E8018-C1 E8018-C1
MINIMUM PREHEAT REQUIREMENT	THICKNESS Up to 1-1/2 Inch 1-1/2 Inch to 2-1/2 Inch Over 2-1/2 Inch			TEMPERATURE 70°F 150°F 225°F			STEEL SD 3510 SD 3520 SD 3526	TEMPERATURE 225°F 300°F 400°F

Viscosity Recommendations

1. Air Line Lubricant

AMBIENT TEMPERATURE	SAE NUMBER
Below 10°F	5W
Above 10°F	10W

2. Hand Oil Can - Viscosity to be suitable for application and temperature.

These performance requirements are benchmarks and not a specification. Therefore, meeting these limits as described above does not relieve the supplier of the responsibility associated with brand name products.

OGL — OPEN GEAR LUBRICANT

Scope

Lubricant performance requirements for the lubrication of open gearing.

Application

Lubrication between mating teeth in an open gear drive.

Methods of Application

1. Heated and either poured or hand sprayed on the gear teeth.
2. Sprayed or dripped on the gear teeth by means of an automatic lubrication system.
3. Applied by means of a cartridge gun.

General Requirements

The following are the requirements of the lubricant at the ambient temperature of the open gear drive.

1. **ADHESIVE** - Maintain film lubricity and be highly resistant to squeeze at contact points of mating surfaces.
2. **FLEXIBILITY** - The coating on the surface of the gear teeth must remain pliable.
3. **EXTREME PRESSURE** - Must withstand the high rolling and sliding contact pressures and have the ability to flow under loads.
4. **CONSISTENCY** - Should maintain consistency.
5. **WATER RESISTANCE** - Ability to resist water washout.

Types of Lubricants

1. **PETROLEUM RESIN AND ASPHALTIC TYPES**
 - a. Hot Melt Type

NOTE: *Since this type must be heated and melted before it is applied to the gears, safety codes should be checked before it is used.*

- b. Diluted Type

This should contain a fast drying diluent such as or equivalent to trichloroethylene. The diluted viscosity must be such that the lubricant can be applied by either spraying or dripping at the ambient temperature of the open gear drive.

Flange wear has the EFFECT of decreasing the roller diameter by virtue of the fact that as the inside flange wears, the roller moves outward from the center of rotation.

A replacement roller as received from Bucyrus-Erie Company must be matched as closely as possible with the adjacent rollers. This can usually be accomplished by machining the inside flange. If the replacement roller was to be installed without this modification it would more than likely fail prematurely due to overloading and or cause damage to the rails and rail supports.

To modify a replacement roller it is recommended that a template be made using the adjacent rollers as a pattern as shown on figure 2. The inside flange of the replacement roller should then be machined accordingly before installation.

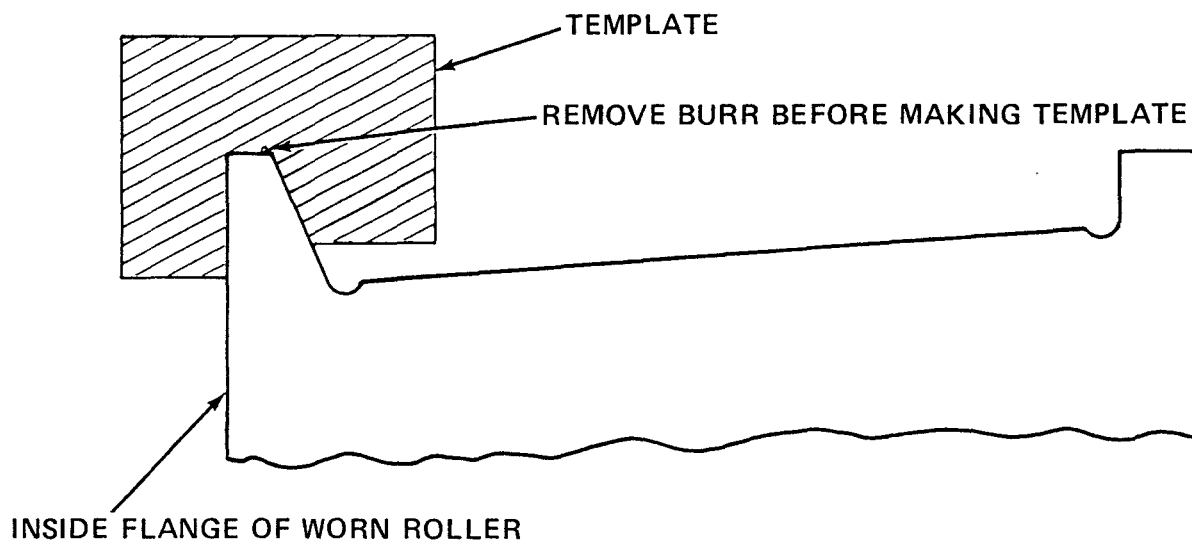

FIGURE 2

In some cases, on older installations, it may also be necessary to modify the rolling surface as well as the inside flange. This case however, is the exception rather than the rule.

SERVICE ASSISTANCE: If additional information or assistance is required, contact:

BUCYRUS-ERIE COMPANY
SERVICE DEPARTMENT
P.O. BOX 56
SOUTH MILWAUKEE, WISCONSIN 53172
PHONE: 414-768-4000

CLICK HERE TO **DOWNLOAD** THE COMPLETE MANUAL

- Thank you very much for reading the preview of the manual.
- You can download the complete manual from: www.heydownloads.com by clicking the link below



- Please note: If there is no response to CLICKING the link, please download this PDF first and then click on it.

CLICK HERE TO **DOWNLOAD** THE COMPLETE MANUAL