



Repair

Manual

Tier III

Print No. 87704086A
English

**ENGINES
CNH NEF**

F4CE - F4DE - F4GE - F4HE

6 Cylinders, Mechanical
and Electronic
Drive Common Rail



**ENGINES
CNH
NEF**

F4CE - F4DE - F4GE - F4HE

**6 Cylinders, Mechanical and
Electronic Drive Common Rail**

**Repair
Manual**

Tier III

CLICK HERE TO **DOWNLOAD** THE COMPLETE MANUAL

- Thank you very much for reading the preview of the manual.
- You can download the complete manual from: www.heydownloads.com by clicking the link below



- Please note: If there is no response to CLICKING the link, please download this PDF first and then click on it.

CLICK HERE TO **DOWNLOAD** THE COMPLETE MANUAL



Put on, where required by the intervention, garments and protections provided in accident prevention rules; contact with moving parts can cause serious injuries. Use suitable, preferably tight-fitted garments, and avoid to use jewels, scarves, etc.

Do not leave the engine in motion at workshop locations not provided with a pipe to scavenge exhaust gas outside.

Avoid to breathe fumes coming from heating or from paint welding because they can cause damages to health; operate outdoors or in suitably ventilated areas. Put on proper inspirator if paint powder is present.

Avoid contact with hot water or steam coming from the engine, radiator and pipings because they could cause serious burns. Avoid direct contact with liquids and fluids present in vehicle systems; where an accidental contact has occurred, refer to 12-point cards for provisions to make.



Clean the assemblies and carefully verify that they are intact prior to overhauling. Tidy up detached or disassembled parts with their securing elements (screws, nuts, etc.) into special containers.

Check for the integrity of the parts which prevent screws from being unscrewed: broken washers, dowels, clips, etc. Self-locking nuts with an insert made of nylon must always be replaced.

Avoid contact of rubber parts with diesel oil, petrol or other not compatible substances.

Before washing under pressure mechanical parts, protect electric connectors, and central units, if present.

Tightening screws and nuts must always be according to prescriptions; FPT commercial and assistance network is available to give all clarifications necessary to perform repair interventions not provided in this document.

Before welding:

- Disconnect all electronic central units, take power cable off battery positive terminal (connect it to chassis bonding) and detach connectors.
- Remove paint by using proper solvents or paint removers and clean relevant surfaces with soap and water.
- Await about 15 minutes before welding.
- Equip with suitable fire resistant protections to protect hoses or other components where fluids or other materials flow which may catch fire easily on welding.

Should the vehicle be subjected to temperatures exceeding 80°C (dryer ovens), disassemble drive electronic central units.



The disposal of all liquids and fluids must be performed with full observance of specific rules in force.

EDC 7 OPERATION

Engine preheating element control

Pre-post heating is activated when even just one of the water, air or fuel temperature sensors detects a temperature ≤ 5 °C.

Phase recognition

By means of signals transmitted by the camshaft and crankshaft sensors, the cylinder into which fuel must be injected is determined at the time of starting.

Injection control

On the basis of information transmitted by the sensors, the control unit administrates the pressure regulator and modifies the pre-injection and main injection mode.

On F4 engines pre-injection is activated at all engine speeds.

Injection pressure closed loop control

On the basis of the engine load, as determined by processing of data transmitted by the various sensors, the control unit administrates the regulator to maintain injection pressure at constantly optimal values.

Pilot and main injection advance control

On the basis of signals transmitted by the various sensors, the control unit determines the optimum injection point on the basis of internal mapping.

Idle speed control

The control unit processes signals transmitted by the various sensors and adjusts the quantity of fuel injected.

It also controls the pressure regulator and modulates injection duration of the electro-injectors.

Within specific limits, the control unit also monitors battery voltage.

Overheating protection

If the water temperature reaches 110 °C, the control unit reduces engine performance.

When the temperature returns below 100 °C, the engine resumes normal operation, (in some applications, the over boosting temperature is the reference temperature).

Maximum engine speed limiting

Depending on the application, the control unit memory can contain appropriate engine speed limits. When the engine speed surpasses these limits the control unit activates power reduction strategies by controlling energization time of the electro-injectors. In some applications the maximum limiting response consists in stopping the engine.

Cut Off

Fuel cut-off in release phases is managed by the control unit with the following logical interventions:

- disactivation of the electro-injectors;
- reactivation of electro-injectors immediately prior to arrival at idle speed;
- control of fuel pressure regulator.

Smoke control under acceleration

With intense load demands, in accordance with signals received from the air inlet meter and the engine speed sensor, the control unit manages the pressure regulator and modulates the activation time of the electro-injectors to prevent the emission of smoke from the exhaust.

After Run

After the engine is stopped, the control unit microprocessor saves various parameters to the EEPROM memory, including the faults log so that they will be available the next time the engine is started.

Control of working speed in normal operating conditions

Each time work load varies, the control unit adjusts torque so as to maintain the engine in maximum power conditions. If the load causes a reduction in power, the control unit increases torque i.e. it increases the amount of fuel injected in order to restore the engine to maximum power.

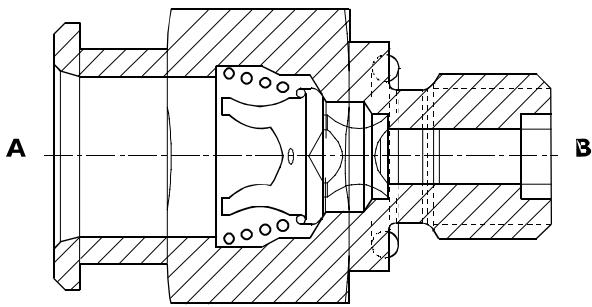
Recovery strategies

Recovery strategies are characterized by certain differences as application varies, i.e.

- Control of fuel leaks
In the case of fuel supply problems, the system controls the engine with suitable constant power values obtained with a low number of revs and high torque values in order to inject the maximum quantity of fuel.
- Control of pressure in the rail
When the pressure in the rail exceeds safety values, the engine reduces power.
- Synchronism problems
In the case of synchronism problems, faulty rev sensors, the system controls the engine by increasing the number of revs in order to improve interpretation of the signals.
- Power restrictions as operating temperature increases
When the temperature of the supercharging air rises above 88 °C, power reduction is started; when a temperature of 120 °C is reached, performance is further reduced and is comparable to that of the same engine if it were aspirated.
- Reduction of power as reference temperature varies
In normal operating conditions, the system knows the supercharging air, oil and water temperatures. If the temperature of the engine water is not available, the system takes the temperature of the oil as reference and when this reaches the threshold of 103 °C, it starts to reduce the power available. On reaching 113 °C, power is reduced to 50%.

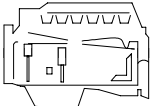

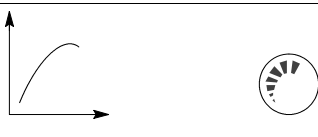
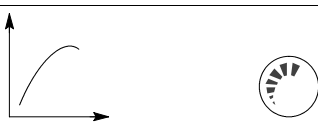


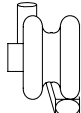


PRESSURE LIMITER FOR FUEL RETURN

It is housed on the rear of the cylinder head, and adjusts the pressure of fuel returning from injectors at a pressure 1.3 and 2 bars. By guaranteeing this pressure to the return fuel, the fuel vapours formation inside injectors is avoided, optimising fuel spraying and combustion.

Figure 15

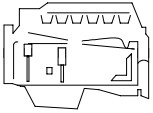





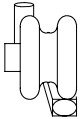


70507

A To tank – B From injectors

	Type	F4HE9684E*J100	
	Compression ratio	17.5 : 1	
	Max. output	kW (HP)	169 (230)
		rpm	2000
	Max. torque	Nm (kgm)	1002 (102)
		rpm	1500
	Loadless engine idling	rpm	-
	Loadless engine peak rpm	rpm	-
	Bore x stroke	104 x 132	
	Displacement	6728	
	TURBOCHARGING	with intercooler	
	Turbocharger type	HOLSET HX35	
	LUBRICATION	Forced by gear pump, relief valve single action oil filter	
	Oil pressure (warm engine)		
	- idling	bar	
	- peak rpm	bar	0.7 3.5
	COOLING	By liquid Through belt	
	Water pump control		
	Thermostat	81 ± 2	
	- start of opening	°C	
	FILLING		
15W40 ACEA E3	engine sump	liters	-
	engine sump + filter	liters	-

NOTE Data, features and performances are valid only if the technician fully complies with all the installation requirements provided by CNH.

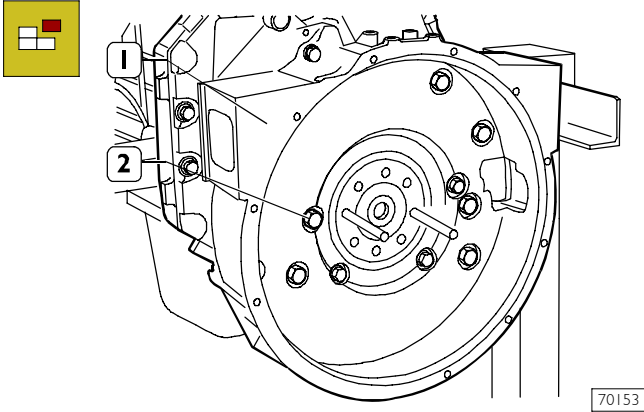
Furthermore, the use of the unit after overhaul should conform to the original specified power and engine rev/min for which the engine has been designed.

	Type	F4HE9684G*J101	
	Compression ratio	17.5 : 1	
	Max. output	kW (HP)	190 (258)
		rpm	2100
	Max. torque	Nm (kgm)	1070 (109)
		rpm	1500
	Loadless engine idling	rpm	-
	Loadless engine peak rpm	rpm	-
	Bore x stroke	104 x 132	
	Displacement	6728	
	TURBOCHARGING	with intercooler	
	Turbocharger type	HOLSET HX35	
	LUBRICATION	Forced by gear pump, relief valve single action oil filter	
	Oil pressure (warm engine)		
	- idling	bar	0.7
	- peak rpm	bar	3.5
	COOLING	By liquid Through belt	
	Water pump control		
	Thermostat	81 ± 2	
	- start of opening	°C	
	FILLING		
15W40 ACEA E3	engine sump	liters	15
	engine sump + filter	liters	15 + 1

NOTE Data, features and performances are valid only if the technician fully complies with all the installation requirements provided by CNH.

Furthermore, the use of the unit after overhaul should conform to the original specified power and engine rev/min for which the engine has been designed.

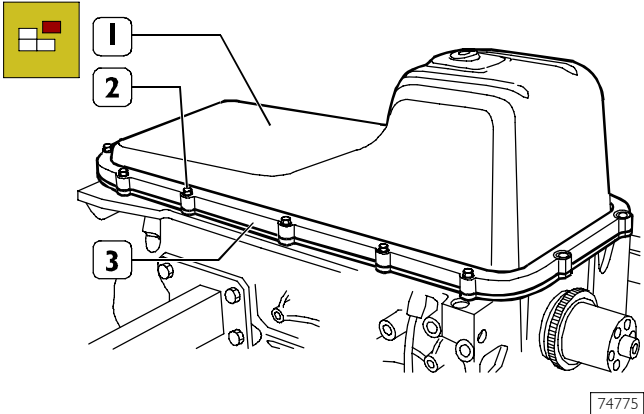
Figure 31



Remove the screws (2) and take out the rear cover (1).

NOTE Take note of screw (2) assembling positions since they have different sizes.

Figure 32



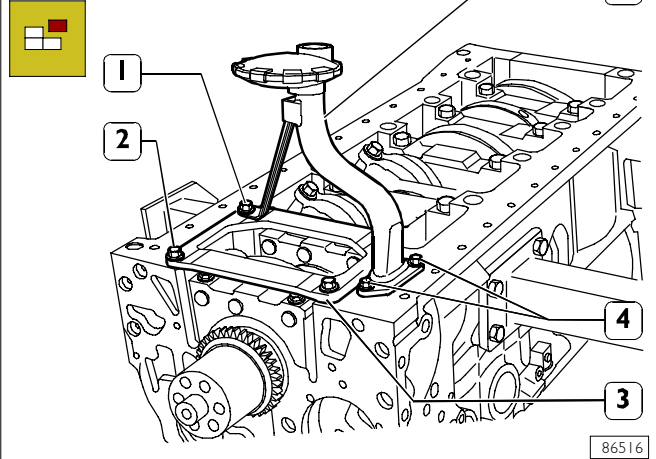
Overtum the engine.

Remove the screws (2), disassemble the plate (3) and disconnect the oil sump (1).

NOTE The shape and the dimensions of the oil pan and of the suction tube may vary according to the duty of the engine. The relevant pictures of the instructions are therefore providing an outline of the intervention to be executed.

However the procedures described are still applicable.

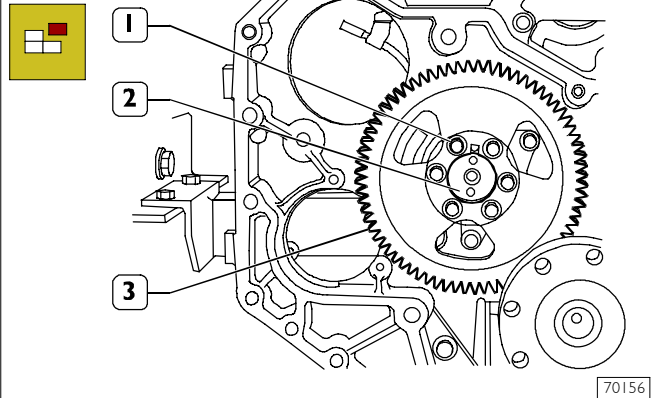
Figure 33



Remove the screws (1 and 4) and disassemble the oil suction tube (5). Remove the screws (2) and disassemble the stiffening plate (3).

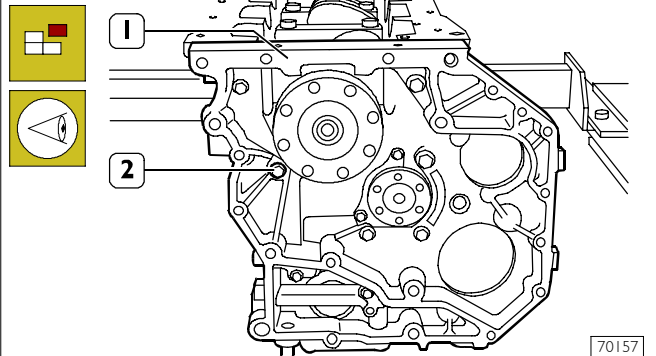
NOTE For engines the stiffening plate (4) has a single element.

Figure 34



Remove the screws (1) and remove the gear (3) from the camshaft (2).

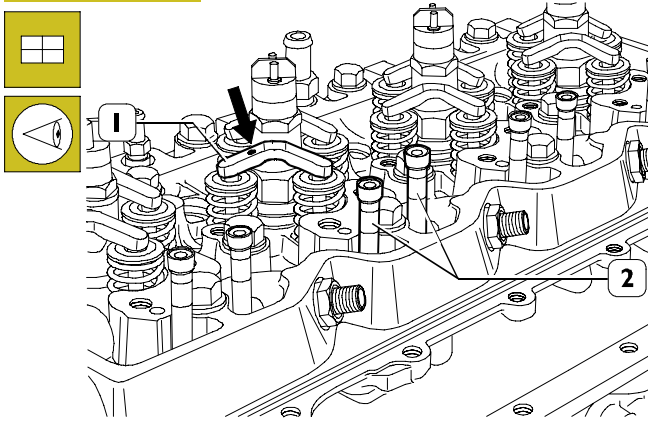
Figure 35



Remove the screws (2) and disconnect the timing gear case (1).

NOTE Take note of screw (2) assembling positions since they have different sizes.

Figure 78

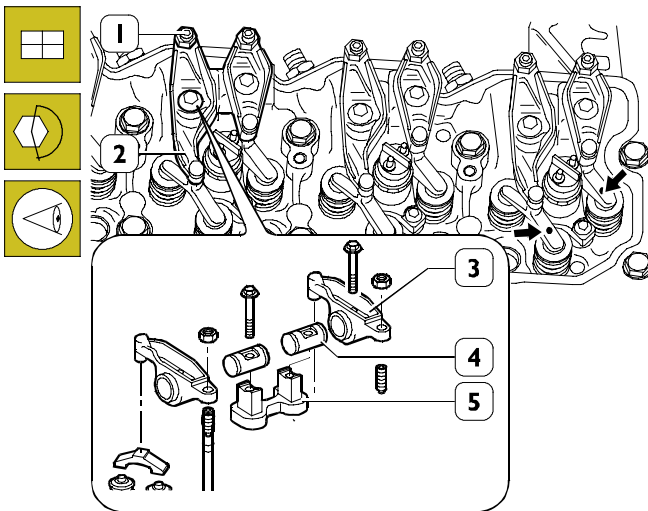


70345

Fit the rods (2).

Position jumpers (1) on valves with marks (→) facing the exhaust manifold.

Figure 79

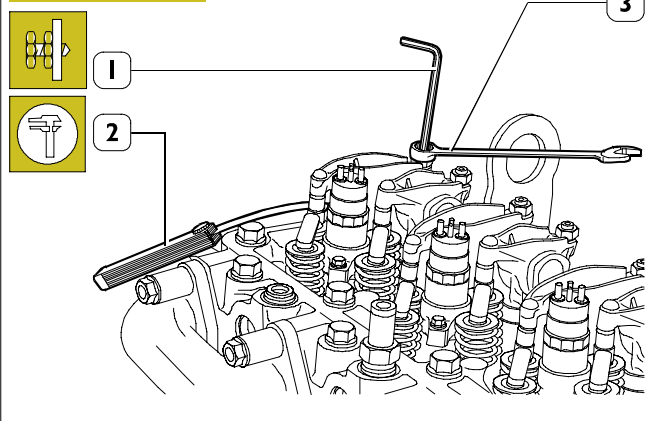


70346

Check that tappet adjusters (1) are loose to prevent their balking on the rods (2, Figure 78) when refitting the rocker assembly.

Then refit the rocker assembly consisting of: bracket (5), rockers (3), shafts (4) and secure them to the cylinder head by tightening the fastening screws (2) to 36 Nm torque.

Figure 80



70520

Adjust clearance between rockers and valves using setscrew wrench (1), box wrench (3) and feeler gauge (2).

Clearance shall be as follows:

- intake valves 0.25 ± 0.05 mm
- exhaust valves 0.50 ± 0.05 mm.

NOTE On TIER 3 engines, due to the additional lobe for the INTERNAL E.G.R., it is not possible to use the valve clearance adjustment procedure that requires adjusting the clearance of all the valves by positioning the crankshaft 2 times only. Each cylinder must be checked by taking it to the T.D.C. (top dead centre) at the end of compression and adjusting the clearance of both valves on the cylinder in question.

Injectors connector (A)

ECU PIN	FUNCTION
1	Cylinder 5 injector
2	Cylinder 6 injector
3	Cylinder 4 injector
4	Cylinder 1 injector
5	Cylinder 3 injector
6	Cylinder 2 injector
7	-
8	-
9	Pressure regulator
10	Pressure regulator
11	Cylinder 2 injector
12	Cylinder 3 injector
13	Cylinder 1 injector
14	Cylinder 4 injector
15	Cylinder 6 injector
16	Cylinder 5 injector

Sensors connector (C)

ECU PIN	ECU PIN
1	-
2	-
3	-
4	-
5	-
6	-
7	-
8	-
9	Timing sensor
10	Timing sensor
11	-
12	Negative for rail temperature and pressure sensor
13	Positive for rail temperature and pressure sensor
14	Signal from rail temperature and pressure sensor
15	Coolant temperature sensor
16	-
17	-
18	Signal from fuel temperature sensor
19	Engine rpm sensor
20	-
21	-
22	-
23	Engine rpm sensor
24	Negative for engine oil pressure and temperature sensor
25	Negative for air temperature and pressure sensor
26	Coolant temperature sensor
27	Signal from engine oil pressure sensor
28	Signal from engine oil temperature sensor
29	-
30	-
31	-
32	Positive for engine oil pressure and temperature sensor
33	Positive for air temperature and pressure sensor
34	Signal from air pressure sensor
35	Negative for fuel temperature sensor
36	Signal from air temperature sensor

Checks not included in maintenance planning-daily checks

It is a good habit to execute, before engine start, a series of simple checks that might represent a valid warranty to avoid inconveniences, even serious, during engine running. Such checks are usually up to the operators and to the vehicle's drivers.

- Level controls and checks of any eventual leakage from the fuel, cooling and lubricating circuits.
- Notify the maintenance if any inconvenience is detected or if any filling is necessary.

After engine start and while engine is running, proceed with the following checks and controls:

- check presence of any eventual leakage from the fuel, cooling and lubricating circuits.
- Verify absence of noise or unusual rattle during engine working.
- Verify, using the vehicle devices, the prescribed pressure temperature and other parameters.
- Visual check of fumes (colour of exhaust emissions)
- Visual check of cooling liquid level, in the expansion tank.

MAINTENANCE PROCEDURES

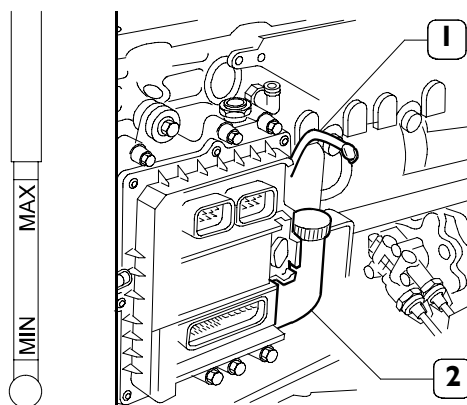
Checks and inspections

Engine oil level check

The check must be executed when the engine is disconnected and possibly cool.

The check can be made using the specially provided flexible rod (1) placed on the right hand side of the EDC.

Figure 110



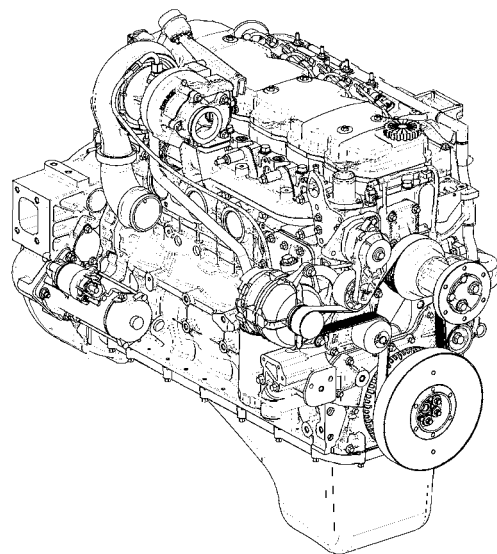
74174

Draw off the rod from its slot and check that the level is within the etched tags of minimum and maximum level.

Whether it should be difficult to make the evaluation, proceed cleaning the rod using a clean cloth with no rag grinding and put it back in its slot. Draw it off again and check the level.

In case the level results being close to the tag showing minimum level, provide filling lubrication of the engine's components.

Figure 111



108540

To provide filling, operate through the upper top or through the lateral top (2, Figure 110). During filling operation, the tops must be removed as well as the rod in order to make the oil flow easier'.

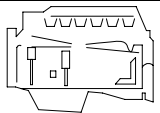
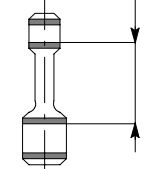
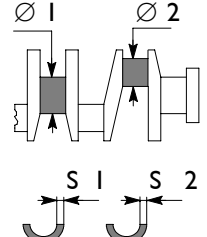
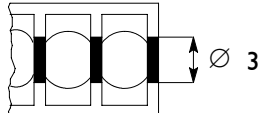



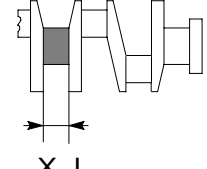
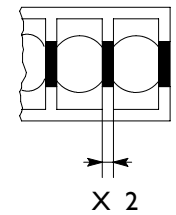
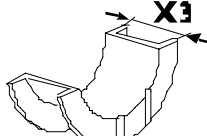



The engine oil is highly polluting and harmful.



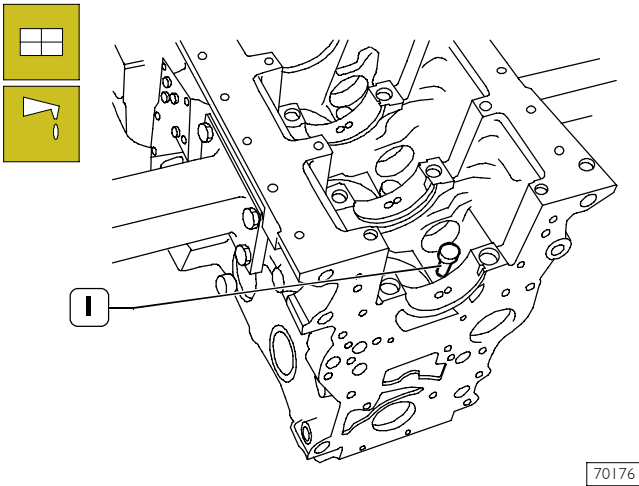
In case of contact with the skin, rinse well with water and detergent.

Adequately protect the skin and the eyes, operate in full compliance with safety regulations. Disposal must be carried out properly, and in full compliance with the law and regulations in force.

 Type	6 CYLINDERS	
CYLINDER UNIT AND CRANKSHAFT COMPONENTS		
mm		
	Size X Max. tolerance on connecting rod axis alignment =	- -
	Journals Ø 1 Crankpins Ø 2 Main half bearings S 1 Big end half bearings S 2	82.99 to 83.01 68.987 to 69.013 2.456 to 2.464 1.955 to 1.968
	Main bearings No. 1-7 Ø 3 No. 2-3-4 Ø 3	87.982 to 88.008 87.977 to 88.013
	Half bearings – Journals No. 1-7 No. 2-3-4-5-6	0.041 to 0.119 0.041 to 0.103
	Half bearings - Crankpins	0.033 to 0.041
	Main half bearings Big end half bearings	0.250 to 0.500
	Shoulder journal X 1	37.475 to 37.545
	Shoulder main bearing X 2	32.180 to 32.280
	Shoulder half-rings X 3	37.28 to 37.38
	Output shaft shoulder	0.095 to 0.265

Fitting tappets – camshaft

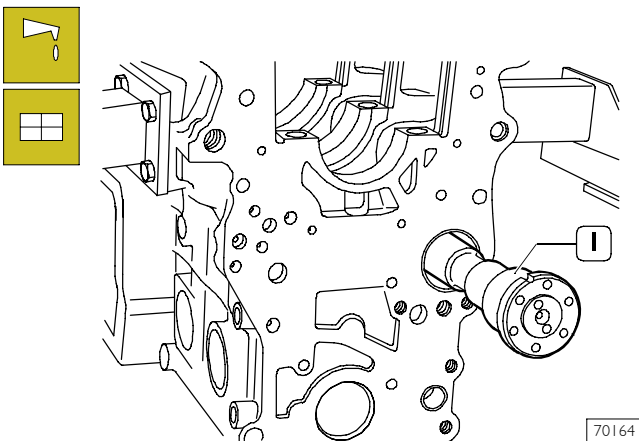
Figure 18



70176

Lubricate the tappets (1) and fit them into the relevant housings on the engine block.

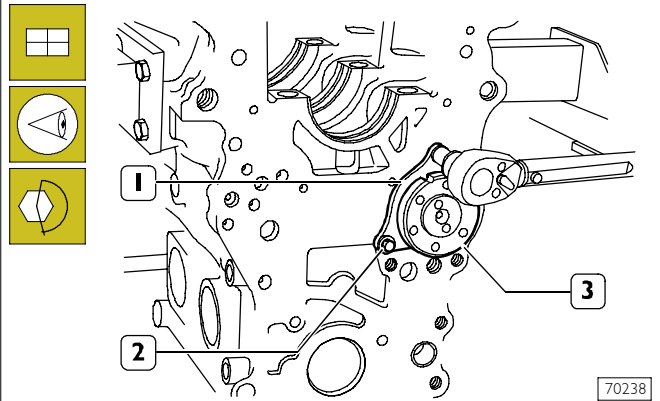
Figure 19



70164

Lubricate the camshaft bush and fit the camshaft (1) taking care not to damage the bush or the housings.

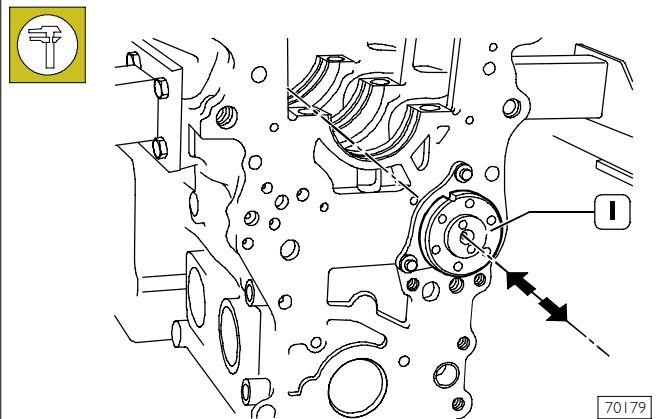
Figure 20



70238

Set camshaft (3) retaining plate (1) with the slot facing the top of the engine block and the marking facing the operator, then tighten the screws (2) to the specified torque.

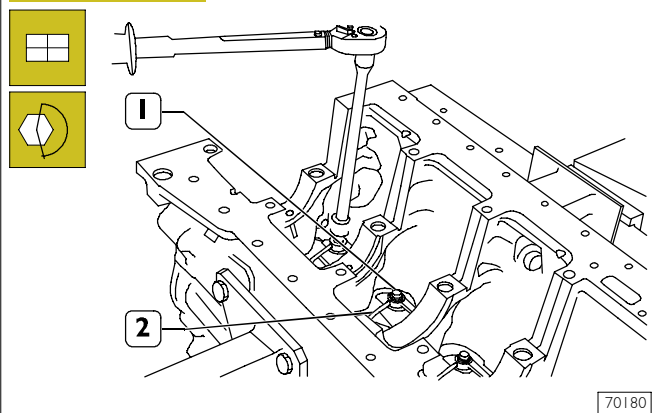
Figure 21



70179

Check camshaft end float (1).
It shall be 0.23 ± 0.13 mm.

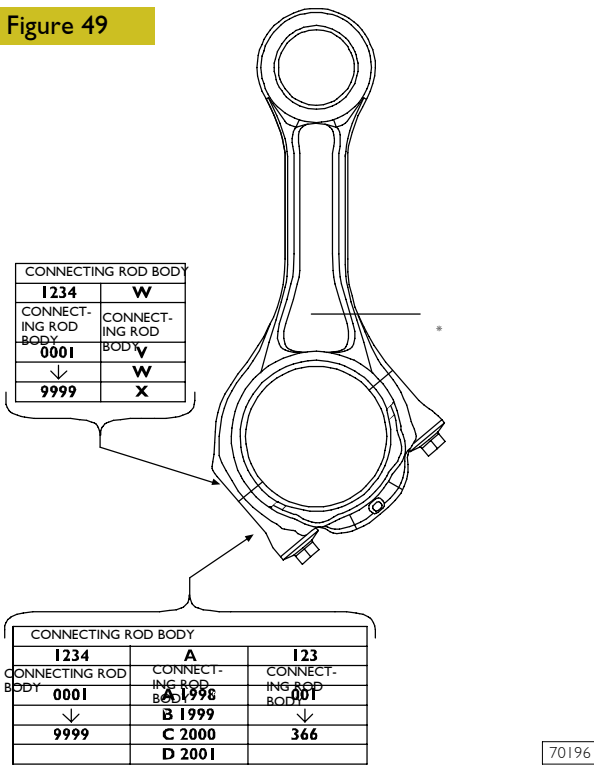
Figure 22



70180

Fit nozzles (2) and tighten the fastening screws (1) to the specified torque.

Figure 49



70196

NOTE Every connecting rod is marked as follows:

- ❑ On body and cap with a number showing their coupling and the corresponding cylinder. In case of replacement it is therefore necessary to mark the new connecting rod with the same numbers of the replaced one.
- ❑ On body with a letter showing the weight of the connecting rod assembled at production:
 - V, 1820 to 1860 (yellow marking);
 - W, 1861 to 1900 (green marking);
 - X, 1901 to 1940 (blue marking);

Spare connecting rods are of the W class with green marking*.

Material removal is not allowed.

Bushes

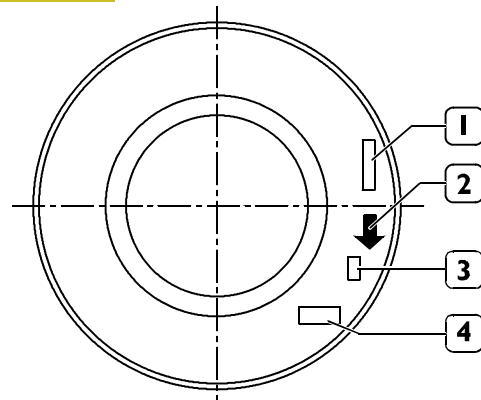
Check that the bush in the connecting rod small end is free from scoring or seizing and that it is not loosen. Otherwise replace.

Removal and refitting shall be performed using the proper beater.

When refitting take care to make coincide the oil holes set on the bush with those set on the connecting rod small end. Grind the bush to obtain the specified diameter.

Fitting connecting rod-piston assembly
Connecting rod-piston coupling

Figure 50

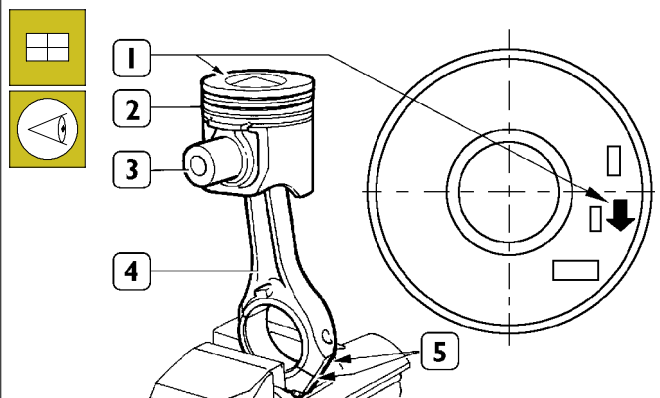


70198

The piston crown is marked as follows:

1. Part number and design modification number;
2. Arrow showing piston assembling direction into cylinder barrel, this arrow shall face the front key of the engine block;
3. Manufacturing date.
4. Marking showing 1st slot insert testing;

Figure 51

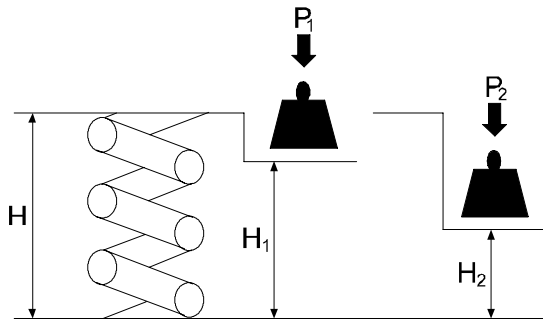


108597

Connect piston (2) to connecting rod (4) with pin (3) so that the reference arrow (1) for fitting the piston (2) into the cylinder barrel and the numbers (5) marked on the connecting rod (5) are read as shown in the figure.

VALVE SPRINGS

Figure 77



50676

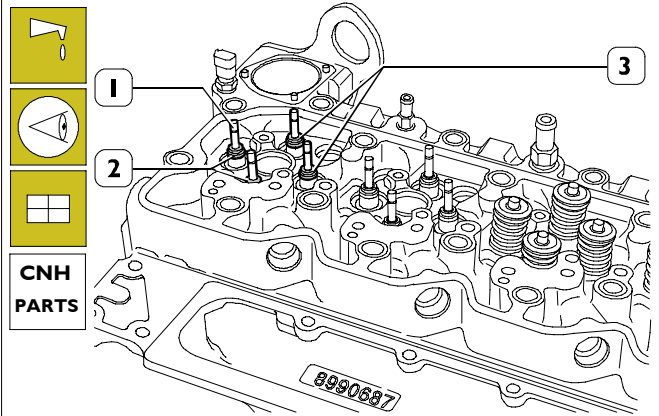
MAIN DATA TO CHECK INTAKE AND EXHAUST VALVE SPRINGS

Before refitting use tool to check spring flexibility. Compare load and elastic deformation data with those of the new springs shown in the following table.

Height	Under a load of	
mm	N	
H	47.75	Free
H ₁	35.33	P 339.8 ± 19 N
H ₂	25.2	PI 741 ± 39 N

FITTING CYLINDER HEAD

Figure 78



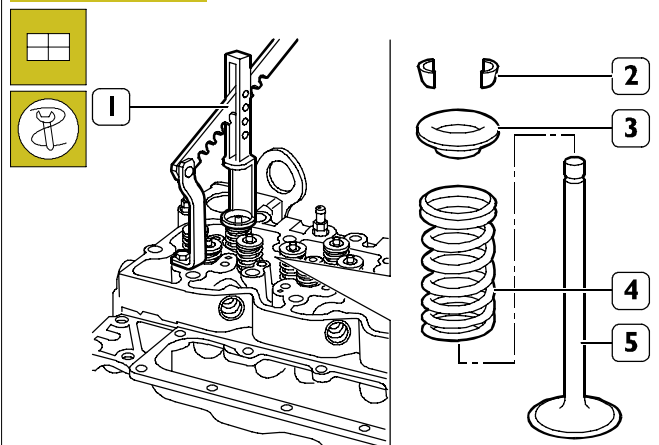
70334

Lubricate the valve stems (1) and fit them into the relevant valve guides according to the position marked at removal.

Fit the sealing rings (2 and 3) on the valve guide.

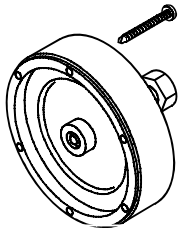
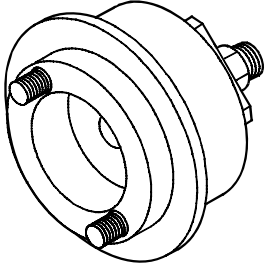
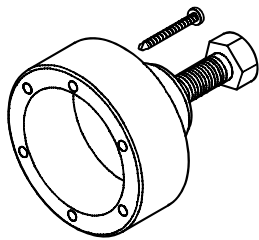
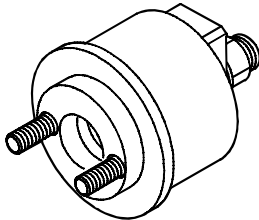
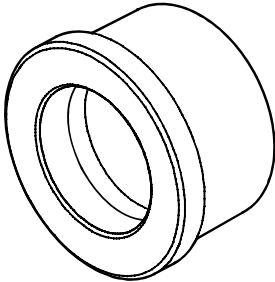
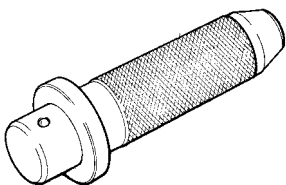
NOTE Sealing rings (2) for intake valves are yellow and sealing rings (3) for exhaust valves are green.

Figure 79



770321

Position on the cylinder head: the spring (4), the upper cap (3); use tool 380000302 (1) to compress the spring (4) and lock the parts to the valve (5) by the coppers (2).

TOOL NO.	DESCRIPTION
380000663	Tool to remove output shaft rear gasket
	
380000664	Tool for fitting output shaft rear gasket
	
380000665	Tool to remove output shaft front gasket
	
380000666	Tool for fitting output shaft front gasket
	
380000667	Beater for removing/refitting camshaft bushes (to be used with 380000668)
	
380000668	Handgrip for interchangeable beaters
	

SECTION I**General specifications**

	Page
LUBRICATION	3
OIL VAPOUR RECIRCULATING SYSTEM	4
COOLING SYSTEM	5
AIR INDUCTION - BOOST DIAGRAM	6
<input type="checkbox"/> Description	6
EXHAUST GAS RE-CIRCULATION SYSTEM (EGR)	7

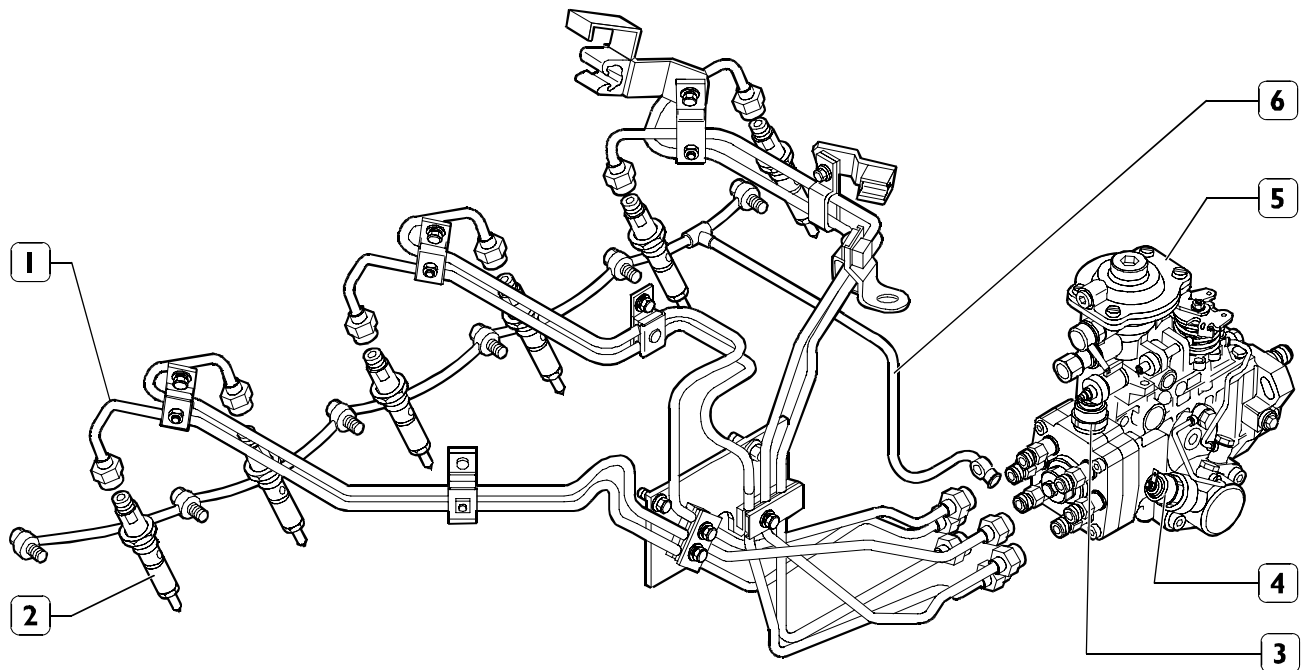
INJECTION FEED SYSTEM BY MECHANICAL ROTARY PUMP

General information

Fuel feed system is composed by:

- Fuel tank (placed on the machine)
- Fuel delivery and back-flow to tank
- Fuel pre-filter (if available, it is usually placed close to the engine on the machine frame)
- Priming pump, assembled to the engine and driven by the camshaft
- Fuel filter (assembled to the engine in different positions according to equipment application and duty)
- Fuel feed rotary pump
- Injector feed pipeline (from fuel feed pump to injectors)
- Injectors

Figure 1

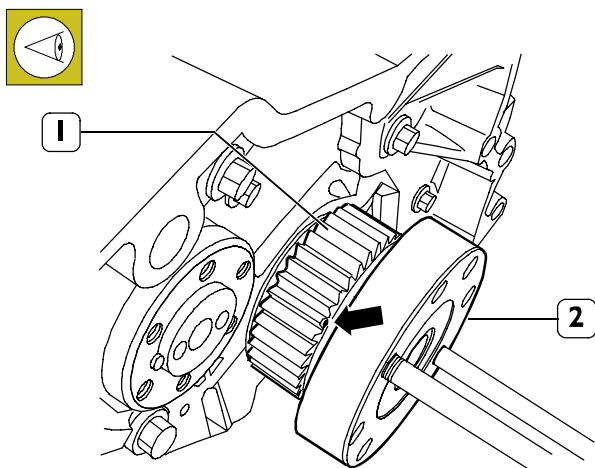


1. Injector feed pipes - 2. Injector - 3. Electro-valve - 4. KSB thermal bulb - 5. Fuel feed rotary pump - 6. Fuel exhaust pipes from injectors.

PART ONE - MECHANICAL COMPONENTS

Installation of application components

Figure 34

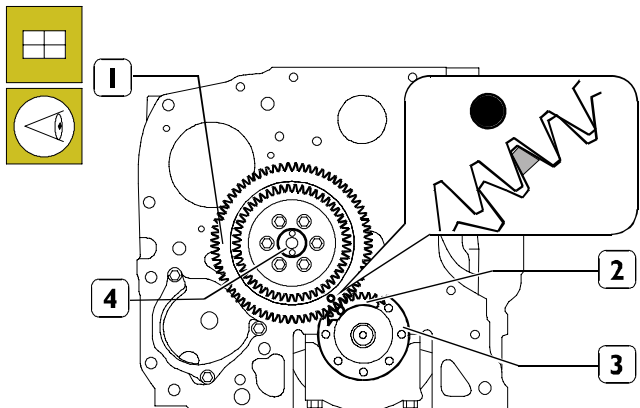


70211

- With a felt-tip pen, highlight the conducting gear tooth (1) mounted on the engine shaft (2) upon the side surface of which a groove has been created for the ignition timing.

NOTE Screw up two pins to facilitate operation of engine drive shaft rotation.

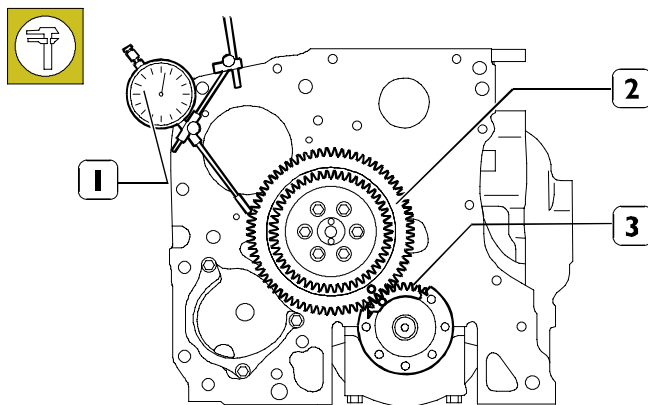
Figure 35



116355

- Turn the engine shaft (3) and the distribution shaft (4) so that by mounting the bevel gear on the latter (1) the stencilled mark on the gear (1) coincides with the groove on the gear tooth (2).

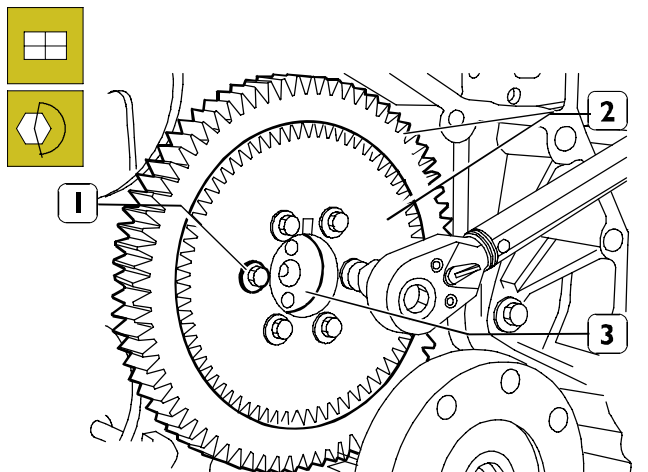
Figure 36



87653

- Place the dial gauge (1) on the timing gear (2) and check that the slack between the gears (2) and (3) is included in the range between $0,076 \pm 0,280$ mm.

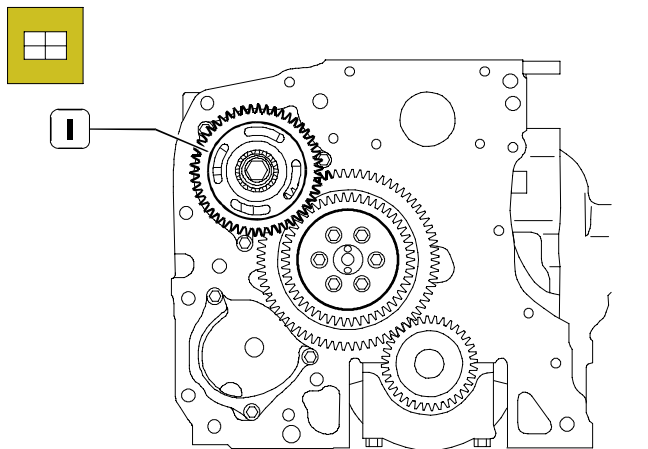
Figure 37



87654

- Fit the screws (1) fastening the gears (2) to the camshaft (3) and tighten them to the prescribed pair.

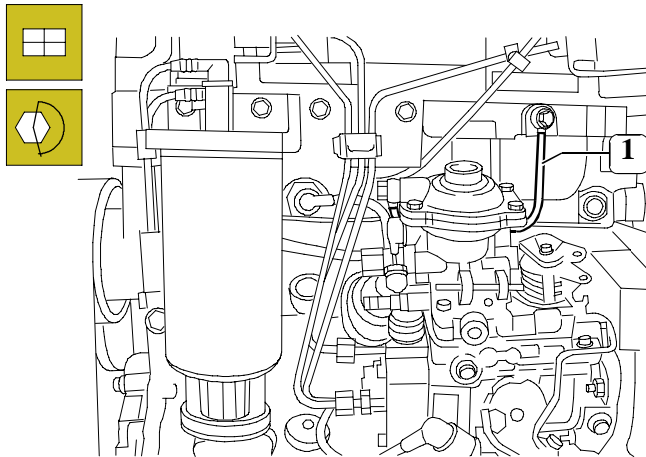
Figure 38



87655

- Spline the gear (1) transferring motion to the ignition pump.

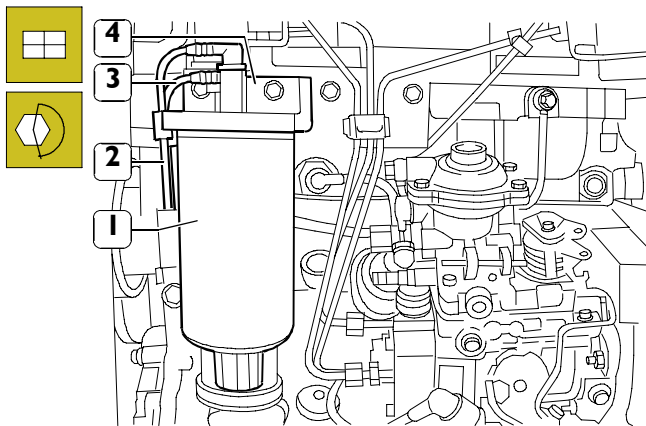
Figure 78



87405

- Fix the LDA pipeline (1) to the engine head and to the feed pump.

Figure 79



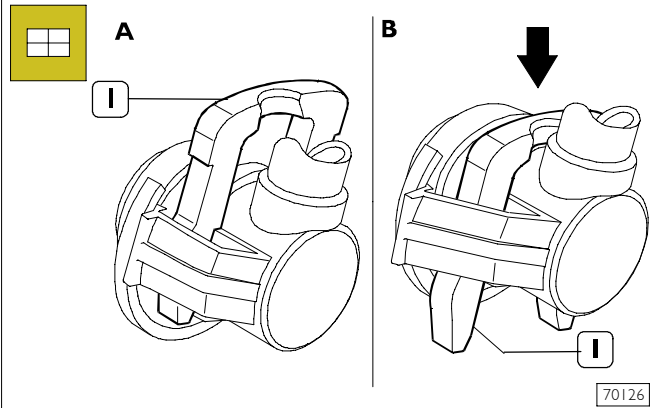
87404

- Assemble the fuel filter bearing (4) to the bracket fixed to the engine head.
- Connect the fuel pipelines (2 and 3) respectively from priming pump to filter bearing and from this last one to feed pump.
- Using 380000670 equipment assemble fuel filter (1).

NOTE The filter shall be priority filled with fuel to facilitate feed system bleed operations.

For the versions requiring it, connect the electrical connections of the sensor detecting presence of water, and of the heater.

Figure 80

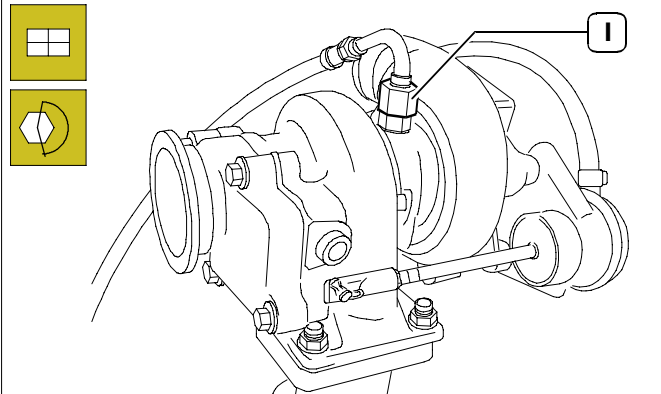


70126

NOTE To connect fuel pipelines (2 and 3, Figure 79) in low pressure from the relating connection unions it is necessary to press the locking fastener (1) as shown in picture B.

After having connected the pipeline, reset the fastener (1) into block position as shown in picture A.

Figure 81



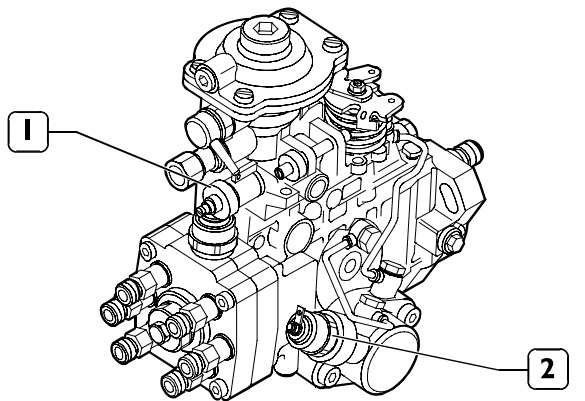
75675

Proceed assembling the turbocharger:

- Hold the turbocharger and place it on the exhaust manifold after having interposed the gasket.
- Screw up the fixing nuts of the turbocharger to the exhaust manifold tightening them to the prescribed couple.
- Tighten the lubrication pipe fixing ring. Operate in the same way on the other end of the pipe. Connect it to the upper part of the heat exchanger.

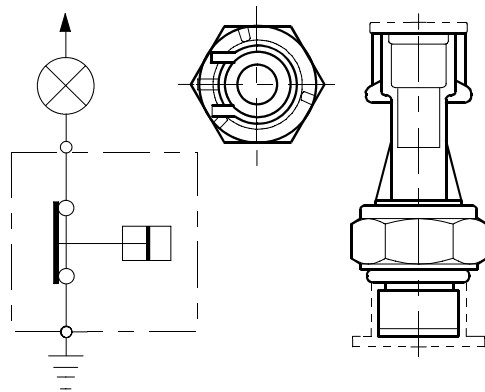
To complete engine assembly it is necessary to remove it from the turning stand.

- Using rocker arm 380000216 hold the engine and loosen the screws fixing the brackets to the turning stand 380000301.
- Disassemble the brackets from the engine after having properly put it on a wooden bearing.

Electromagnets assembled to feed pump**Figure 101**

88321

1 - Hydraulic head Electro-magnet; 2 - KSB Electro-magnet

Oil pressure switch**Figure 103**

75722

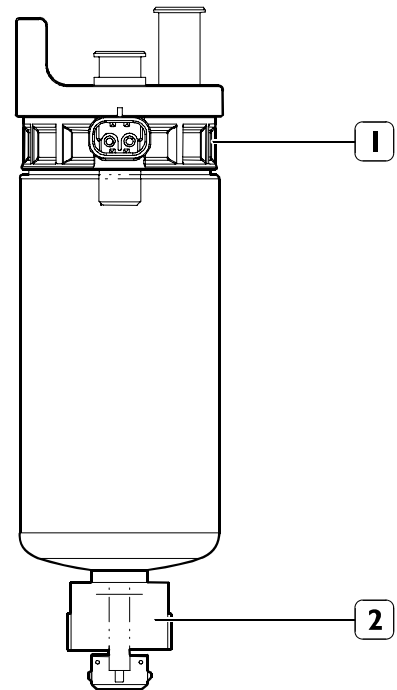
It is assembled to the block on the engine's left hand side.

Specifications:

Working tensions: 12 ÷ 24 V

Contact closure upon lower pressure: 0.6 bar

Contact opening upon higher pressure: 0.9 bar

Fuel filter**Figure 102**

88319

1. Heater - 2. Water detecting sensor.

On the basis of the fuel filter there is a sensor detecting the presence of water. For the use requiring it (use in cold climate conditions) a heater provided with connector for heat resistance of the fuel filter may be interposed between the filter support and the filtering cartridge.

PART FOUR - MAINTENANCE PLANNING

GENERAL SPECIFICATIONS

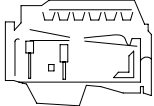
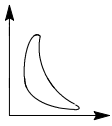
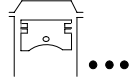
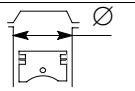
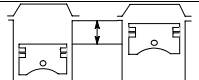
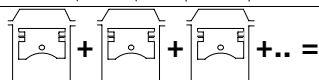
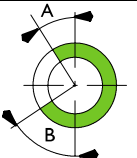

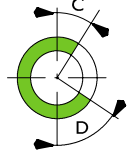

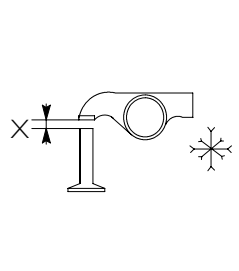
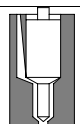
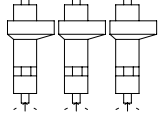
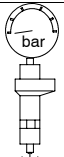
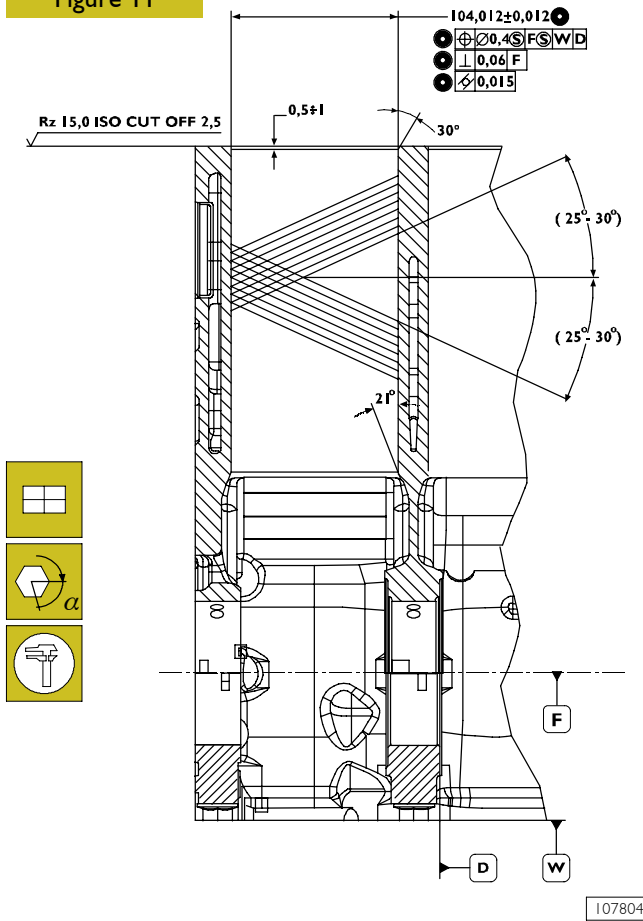
	Type	6 CYLINDERS	
	Cycle	Four-stroke diesel engine	
	Power	Turbocharged with intercooler	
	Injection	Direct	
	Number of cylinders	6	
	Bore	mm	104
	Stroke	mm	132
	Total displacement	cm ³	6728
TIMING			
	 start before T.D.C. end after B.D.C.	A B	15° 35°
	 start before B.D.C. end after T.D.C.	D C	69° 21°
	Checking timing	X	mm
	Checking operation	X	mm
FUEL FEED			
	Injection Type:	Bosch	VE 6/12F ...
	Nozzle type	DSL A 145 P	
	Injection sequence	1 - 5 - 3 - 6 - 2 - 4	
	Injection pressure bar	-	

Figure 11



NOTE In case of regrinding, all barrels shall have the same oversize (0.4 mm).

Check main bearing housings as follows:

- fit the main bearings caps on the supports without bearings;
- tighten the fastening screws to the specified torque;
- use the proper internal gauge to check whether the housing diameter is falling within the specified value.

Replace if higher value is found.

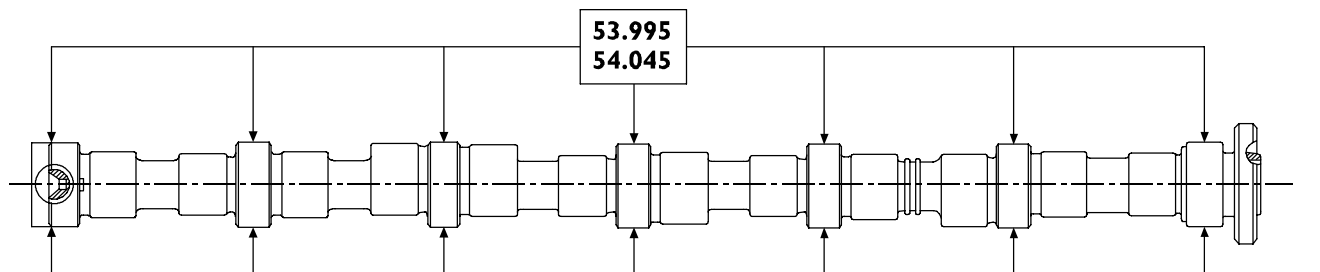
Checking head supporting surface on cylinder unit

When finding the distortion areas, replace the cylinder unit. Planarity error shall not exceed 0.075 mm.

Check cylinder unit operating plug conditions, replace them in case of uncertain seal or if rusted.

TIMING SYSTEM
Camshaft

Figure 12



70512

CAMSHAFT MAIN DATA (6 cyl.)
The data reported refer to standard diameter (dimensions in mm) of pins

Figure 46

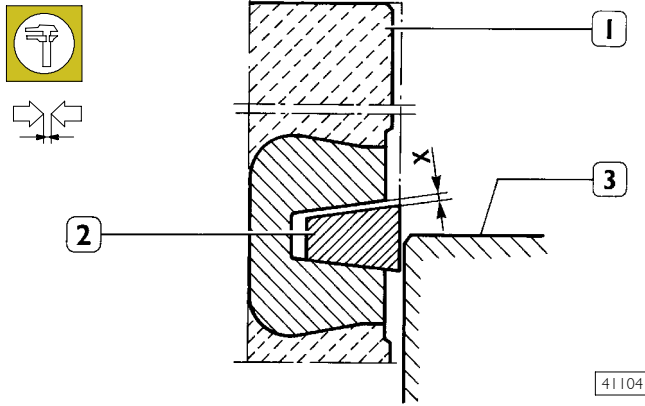
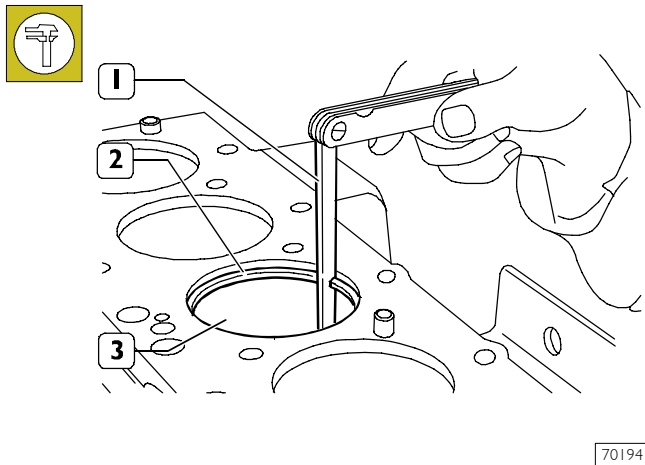


DIAGRAM FOR MEASURING THE CLEARANCE X BETWEEN THE FIRST PISTON SLOT AND THE TRAPEZOIDAL RING (supercharged engines only)

Since the first sealing ring section is trapezoidal, the clearance between the slot and the ring shall be measured as follows: make the piston (1) protrude from the engine block so that the ring (2) protrudes half-way from the cylinder barrel (3).

In this position, use a feeler gauge to check the clearance (X) between ring and slot: found value shall be the specified one.

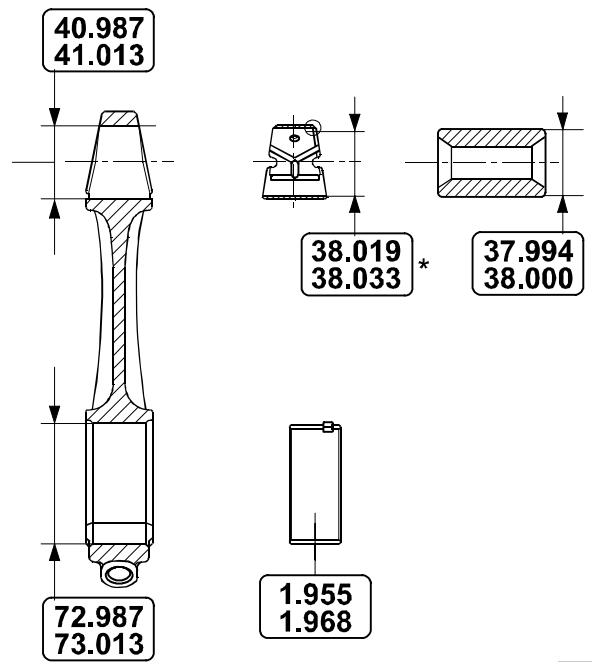
Figure 47



Use feeler gauge (1) to measure the clearance between the ends of the split rings (2) fitted into the cylinder barrel (3).

Connecting rods

Figure 48



MAIN DATA FOR CONNECTING ROD, BUSH, PISTON PIN AND HALF BEARINGS

* Value for inside diameter to be obtained after driving in connecting rod small end and grinding.

NOTE The surface of connecting rod and rod cap are knurled to ensure better coupling. Therefore, it is recommended not to smooth the knurls.

CLICK HERE TO **DOWNLOAD** THE COMPLETE MANUAL

- Thank you very much for reading the preview of the manual.
- You can download the complete manual from: www.heydownloads.com by clicking the link below

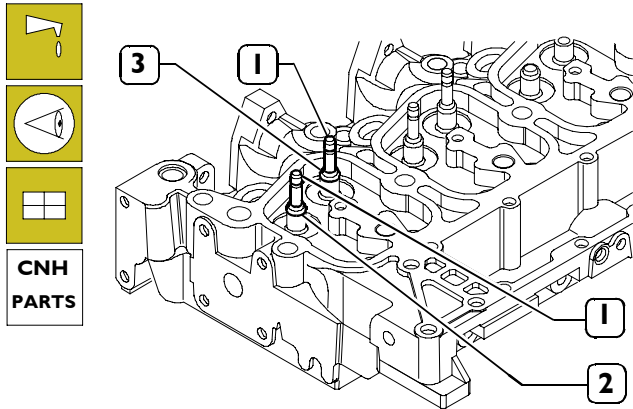


- Please note: If there is no response to CLICKING the link, please download this PDF first and then click on it.

CLICK HERE TO **DOWNLOAD** THE COMPLETE MANUAL

FITTING CYLINDER HEAD

Figure 78

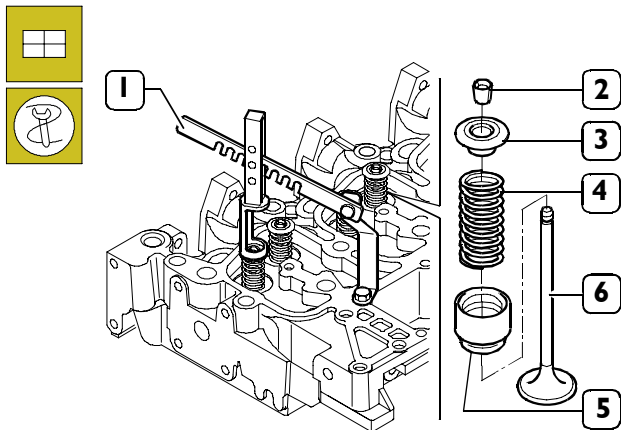


75759

Lubricate the valve stems (1) and fit them into the relevant valve guides according to the position marked at removal.

Fit the sealing rings (2 and 3) on the valve guide.

Figure 79

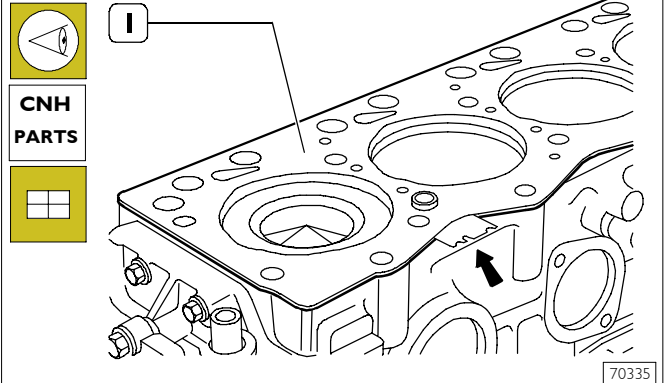


75751

Position on the cylinder head: the protection cap (5), the spring (4), the upper cap (3); use tool 380000302 (1) to compress the spring (4) and lock the parts to the valve (6) by the cotters (2).

Refitting the cylinder head

Figure 80



70335

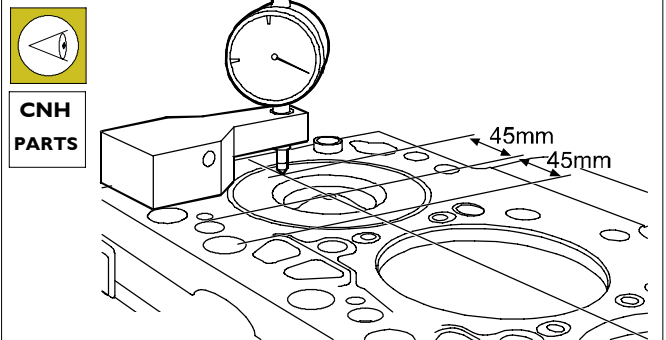
Check cleanness of cylinder head and engine block coupling surface.

Take care not to foul the cylinder head gasket.

Set the cylinder head gasket (1) with the marking "TOP" (1) facing the head.

The arrow shows the point where the gasket thickness is given.

Figure 81



88775

There are two types of head seals for F4AE04.., F4AE06.. and F4HE06.. engines, for the thickness (1.25 mm Type A and 1.15 mm Type B) take the following measures:

□ for each piston detect, as indicated on Figure 81, at a distance of 45 mm from the centre of the piston overhangs S1 and S2 in relation to the engine base upper plane then calculate the average:

$$S_{cil1} = \frac{S1 + S2}{2}$$

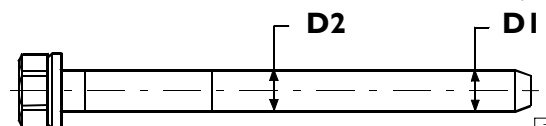
Repeat the operation for pistons 2, 3, 4, 5 and 6 and calculate the average value.

$$S = \frac{S_{cil1} + S_{cil2} + S_{cil3} + S_{cil4} + S_{cil5} + S_{cil6}}{6}$$

If S is > 0,40 mm use seal type A.

If S is < 0,40 mm use seal type B.

NOTE Before using the fixing screws again, measure them twice as indicated in the picture, checking D1 and D2 diameters:
 if D1 - D2 < 0,1 mm the screw can be utilised again;
 if D1 - D2 > 0,1 mm the screw must be replaced.

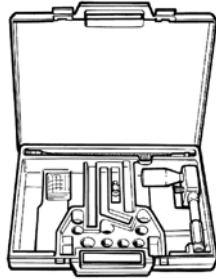


75703

TOOLS

TOOL NO.

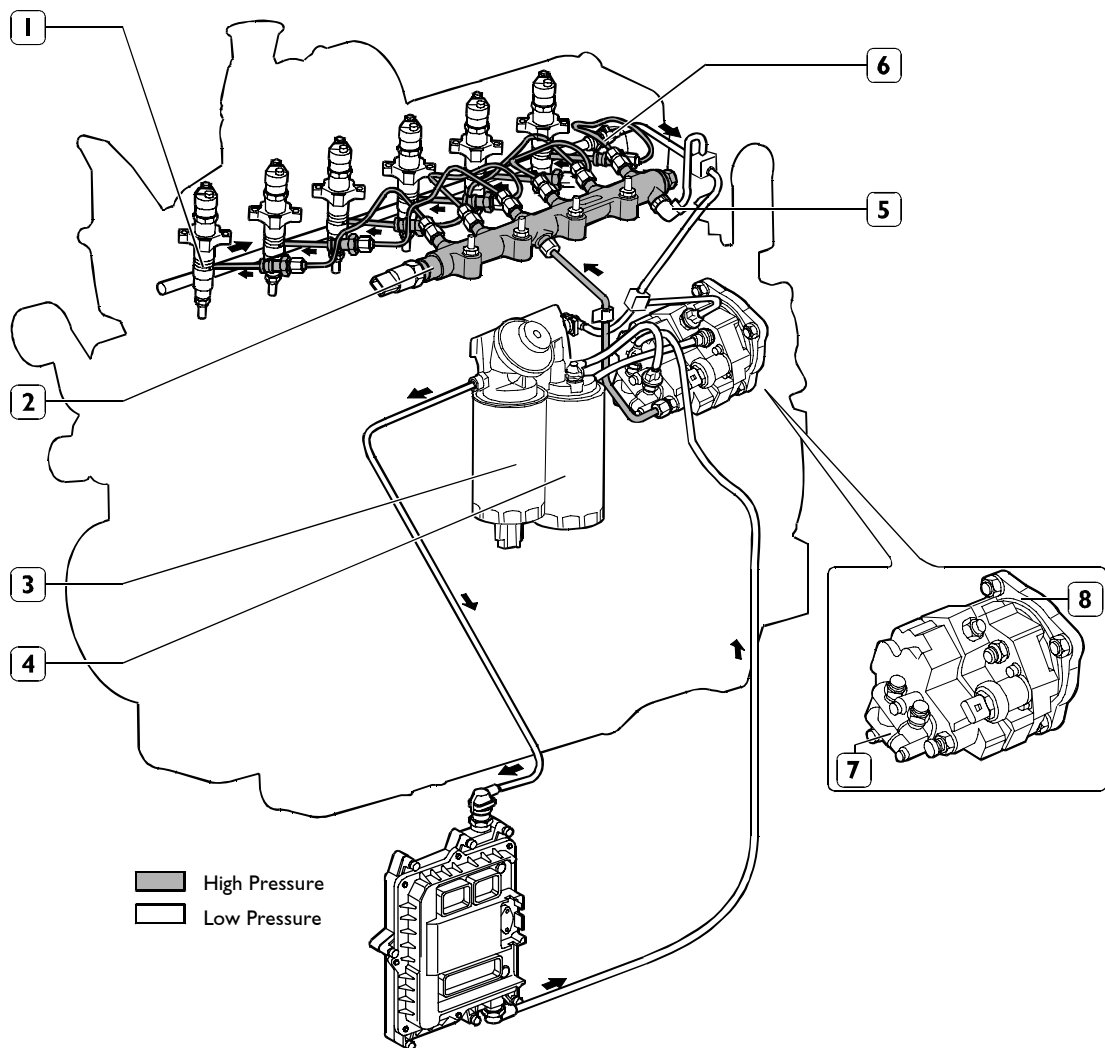
DESCRIPTION

380001006

Dial gauge (0 – 5 mm)

SECTION I**General specifications**

	Page
LUBRICATION	3
COOLING SYSTEM	4
AIR INDUCTION BOOST DIAGRAM	5
<input type="checkbox"/> Description	5
EXHAUST GAS RE-CIRCULATION SYSTEM (EGR)	6

WORKING PROCESS**Figure 2**

1. Injector - 2. Common Rail - 3. Pressure limiter for fuel return - 4. Rail overpressure valve - 5. Prefilter assembled on chassis - 6. High-pressure pump - 7. Mechanical rotor pump - 8. Fuel filter.

The Common Rail system has a special pump that continuously keeps fuel at high pressure, independently from stroke and cylinder that has to receive the injection and accumulates fuel in a common duct for all injectors.

Therefore, fuel at the injection pressure computed by the ECU is always available at the injectors inlet.

When an injector solenoid valve is energised by the electronic control unit, the injection of fuel directly taken from rail takes place in the related cylinder.

The hydraulic system is implemented by a low-pressure circuit and a high-pressure circuit.

The high-pressure circuit is composed of the following pipings:

- piping connecting high-pressure pump outlet to rail;
- pipings supplying injectors from rail.

The low-pressure circuit is composed of the following pipings:

- fuel suction piping from tank to prefilter;
- pipings supplying the mechanical supply pump through the control unit heat exchanger, manual priming pump and prefilter;
- pipings supplying the high-pressure pump through the fuel filter.

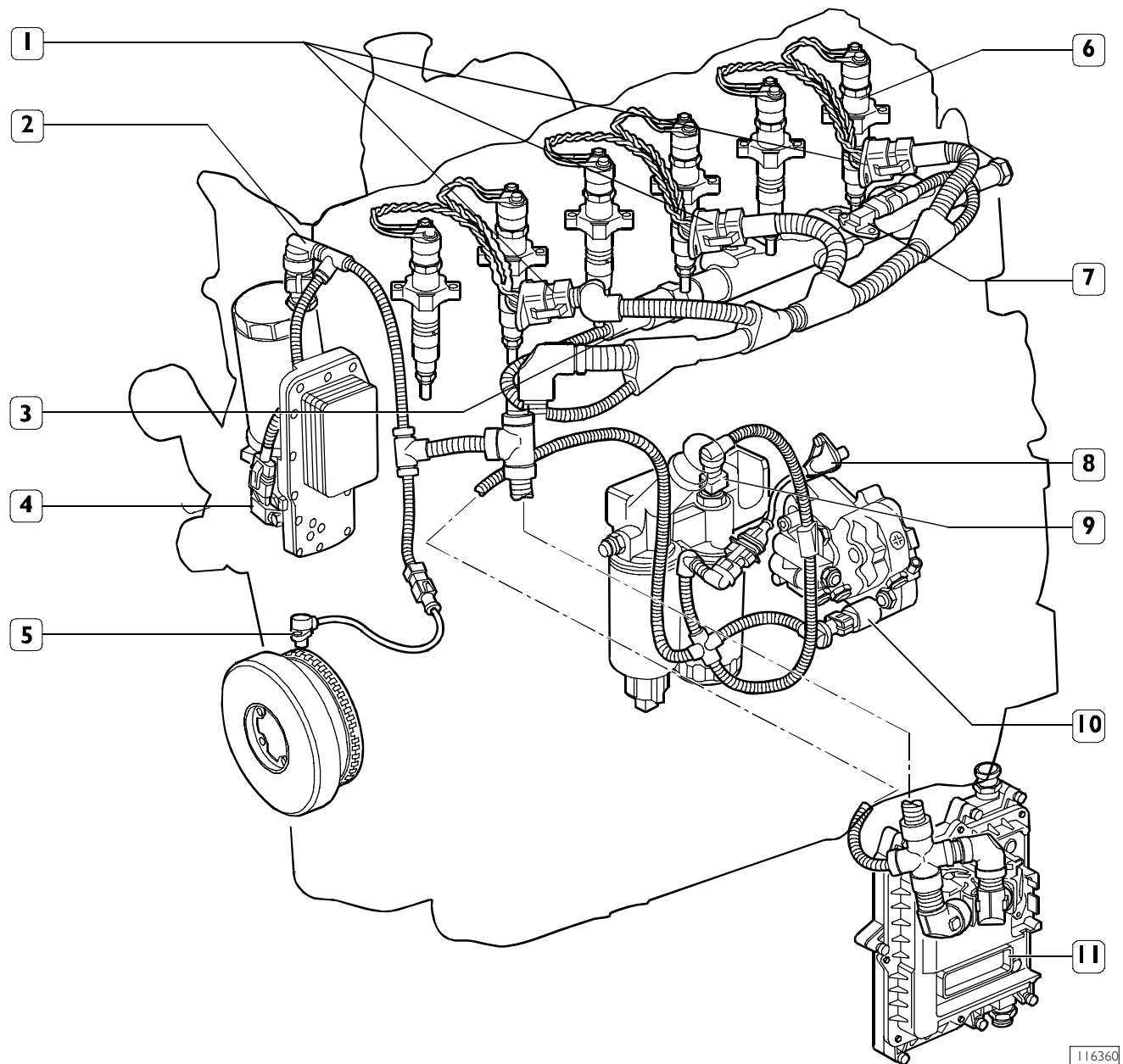
The fuel draining circuit from rail and from injectors and the high-pressure pump cooling circuit complete the system.

SECTION 3**Industrial application**

	Page
GENERAL SPECIFICATIONS	3
<input type="checkbox"/> Section pictures of complete engine - common rail version	3
<input type="checkbox"/> Clearance data - 6 cyl.	4
PART ONE - MECHANICAL COMPONENTS .	7
ENGINE OVERHAUL	9
<input type="checkbox"/> Preface	9
<input type="checkbox"/> Engine setting operations for the assembly on turning stand	9
<input type="checkbox"/> Disassembly of application components	11
<input type="checkbox"/> Assembly of application components	18
<input type="checkbox"/> Completion of the engine	28
<input type="checkbox"/> Checks and inspections	29
PART TWO - ELECTRICAL EQUIPMENT	31
LOCATION OF MAIN ELECTRICAL COMPONENTS	33
<input type="checkbox"/> EDC7 ECU	34
<input type="checkbox"/> Connector to injectors (A)	35
<input type="checkbox"/> Feed connector (B) to components and to functions of the specific equipment	36
<input type="checkbox"/> Connector to sensors (C)	37
<input type="checkbox"/> Temperature and air-pressure sensor	38
<input type="checkbox"/> Sensor of engine's oil temperature and pressure	38
<input type="checkbox"/> Driving shaft sensor	38
<input type="checkbox"/> Timing system sensor	38
<input type="checkbox"/> Fuel pressure sensor	39

Disassembly of application components

Figure 7

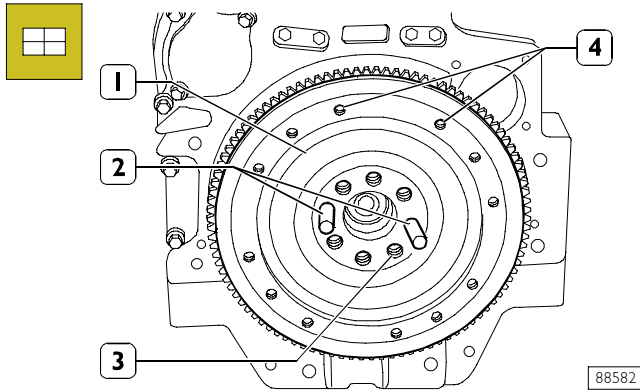


1. Connections for Electro-injectors - 2. Engine cooling liquid temperature's sensor - 2. Cable of the fuel pressure sensor -
 4. Sensor of engine's oil temperature and pressure - 5. Driving shaft sensor -
 6. Electro-injector - 7. Temperature - air pressure sensor - 8. Timing system sensor - 9. Cable of fuel heater and fuel
 temperature's sensor - 10. Cable of pressure regulating gauge - 11. EDC 7 electronic module.

Disconnect the engine's cable from the connectors (1, Figure 7) wiring harness to Electro-injectors (6); (7) air pressure/temperature sensor; (3) fuel pressure sensor; (11) engine control module; (10) high pressure pump sensor; (8) timing system sensor; (2) Thermostat sensor of engine cooling liquid's temperature; (5) sensor of engine's revolutions.

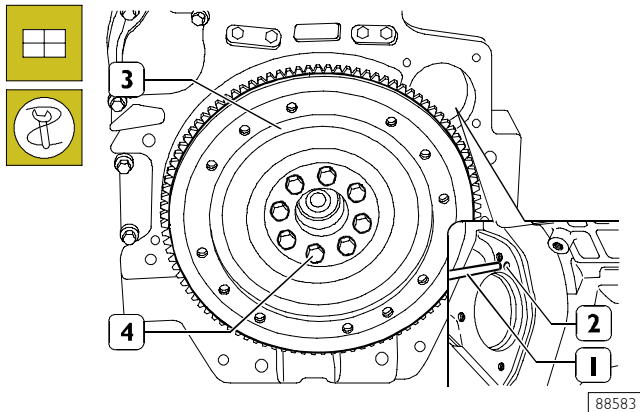
Disassemble the engine from the engine block removing the fixing clamps.

Figure 46



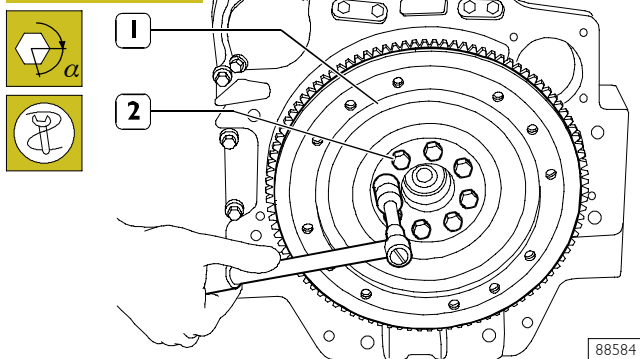
Screw two manoeuvring hooks or lunettes on flywheel (1) using holes (4).
 With the help of a hoist bring the flywheel closer to its seat inside the flywheel housing box.
 Screw two pins (2) with proper length for shaft holes (3) and use them as guides, assemble engine flywheel (1) by arranging it properly in the flywheel housing box.

Figure 47



Screw engine flywheel (3) fixing screws (4) on the engine shaft. Put the tool in the proper hole (2) in order to block engine flywheel rotation.

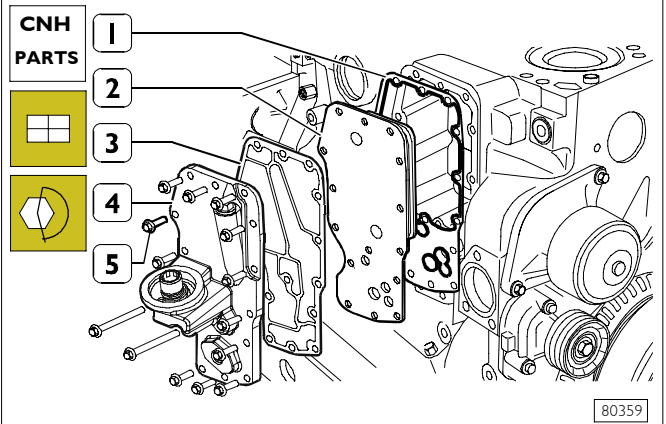
Figure 48



Tighten engine flywheel (1) fastening screws (2).

NOTE Tightening to angle is performed using tool 380000304. Before any assembly operation always verify that the hole and screw threads have no evidence of wear or dirt.

Figure 49

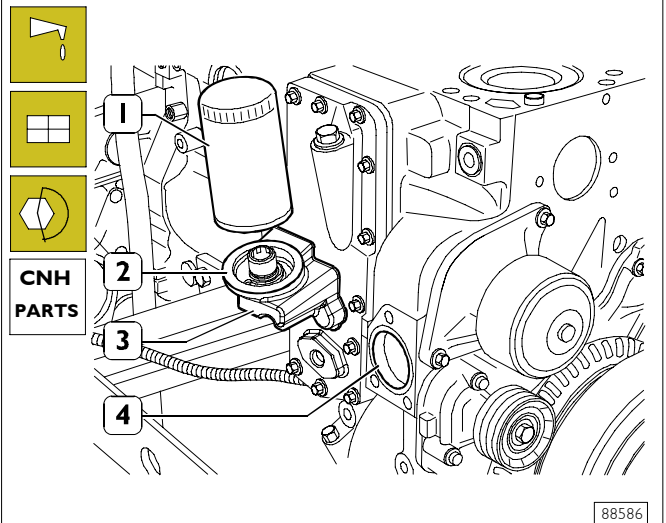


Fit on the engine block: a new gasket (1), the heat exchanger (2) a new gasket (3) and the oil filter support (4).

Tighten the screws (5) to the specified torque.

NOTE Before any assembly operation always verify that the hole and screw threads have no evidence of wear or dirt.

Figure 50



Lubricate the sealing ring (2) with engine oil and set it on the oil filter (3).

Screw manually to seat the oil filter (3) on the support connection (1) and then screw again the oil filter (3) by 3/4 turn.

Apply a new sealing ring on the oil temperature/pressure sensor (4) and fit it on the support (1).

Tighten the screws (5) to the specified torque.

Fit a new sealing ring (6) in the engine block seat.

PART TWO - ELECTRICAL EQUIPMENT

PART THREE - TROUBLESHOOTING

MAINTENANCE PLANNING

Recovery

To ensure optimised working conditions, in the following pages we are providing instructions for the overhaul control interventions, checks and setting operations that must be performed on the engine at due planned dates.

The frequency of the maintenance operations is just an indication since the use of the engine is the main characteristic to determine and evaluate replacements and checks.

It is not only allowed but recommended that the staff in charge of the maintenance should also carry out the necessary maintenance and controlling operations even if not being included in the ones listed here below but that may be suggested by common sense and by the specific conditions in which the engine is run.

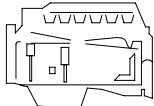
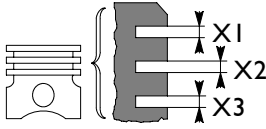

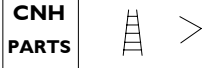
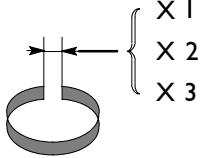
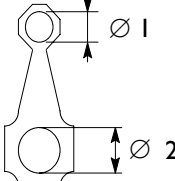
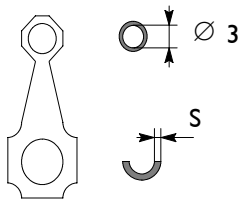


Regular maintenance and inspection planning

Checks and periodical inspections	Frequency (hours)
Visual check of engine	Daily
Inspection presence of water in fuel filter or pre-filter	Daily
Inspection of belt wear status	-
Inspection and setting of tappet clearance	4000
EDC	-
Replacement of engine's oil and filter	500
Replacement of pre-filter	1000
Replacement of fuel filter	500
Replacement of belt	1500

NOTE The frequency of the maintenance operations is just an indication since the use of the engine is the main characteristic to determine and evaluate replacements and checks.

The maintenance operations are valid only if the setter fully complies with all the installation prescriptions provided by CNH.

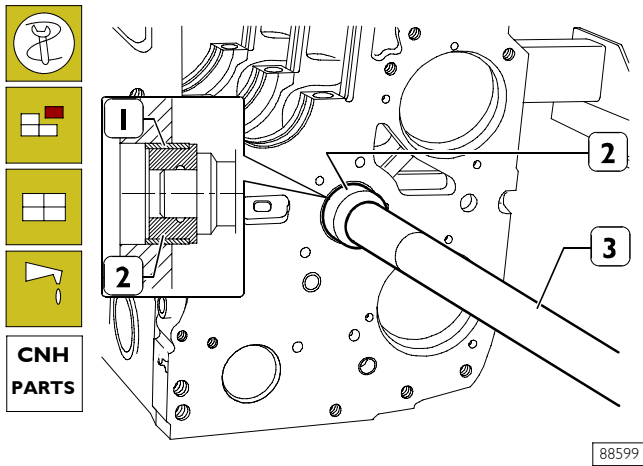
Furthermore, the users assembled by the setter shall always be in conformance to couple, power and number of turns based on which the engine has been designed.

		Type	6 CYLINDER
CYLINDER UNIT AND CRANKSHAFT COMPONENTS			mm
	Split ring slots	X1* X2 X3 * measured on 101 mm Ø	2.705 to 2.735 2.440 to 2.460 / 2.420 to 2.440 (•) 4.030 to 4.050
	Split rings	S 1 S 2 S 3	2.560 to 2.605 2.350 to 2.380 3.970 to 3.990
	Split rings - slots	1 2 3	0.100 to 0.175 0,060 to 0,110 / 0.040 to 0.090 (•) 0.040 to 0.080
	Split rings		0.4
	Split ring end opening in cylinder barrel:	X 1 X 2 X 3 X 1 X 2 X 3	0.30 to 0.40 0.60 to 0.80 0.30 to 0.55
	Small end bush housing Big end bearing housing	Ø 1 Ø 2	40.987 to 41.013 72.987 to 73.013
	Small end bush diameter Inside Big end half bearings	Ø 3 Ø 3 S	38.019 to 38.033 1.955 to 1.968
	Piston pin – bush		0.019 to 0.033
	Big end half bearings		0.250 ; 0.500

(•) Valid for engines F4DE9684B
 F4DE9684L
 F4DE9684N
 F4DE9684S

Bush replacement

Figure 16

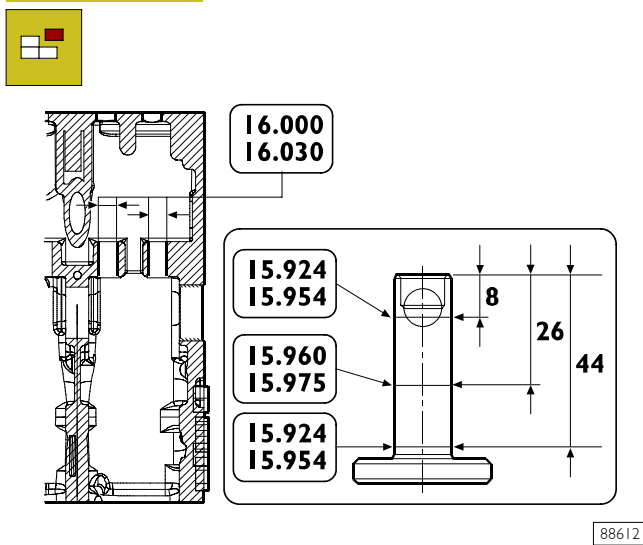


To replace bush (1), remove and refit it using the beater 380000667 (2) and the handgrip 380000668 (3).

NOTE When refitting the bush (1), direct them to make the lubricating holes (2) coincide with the holes on the block housing.

Tappets

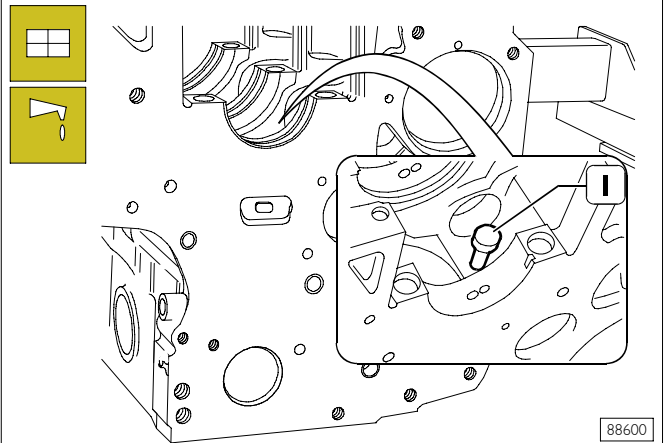
Figure 17



MAIN DATA CONCERNING THE TAPPETS AND THE RELEVANT HOUSINGS ON THE ENGINE BLOCK

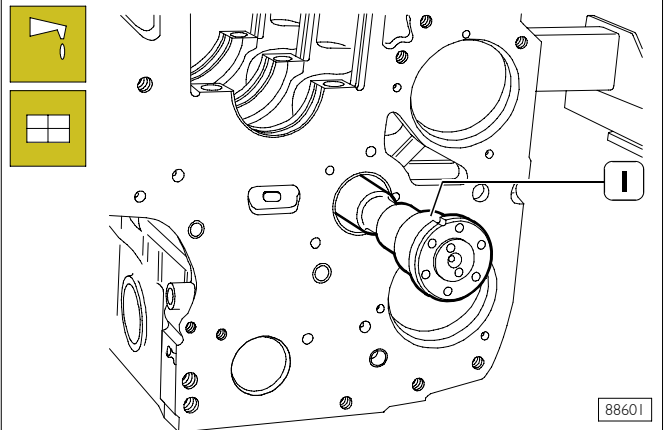
Fitting tappets – camshaft

Figure 18



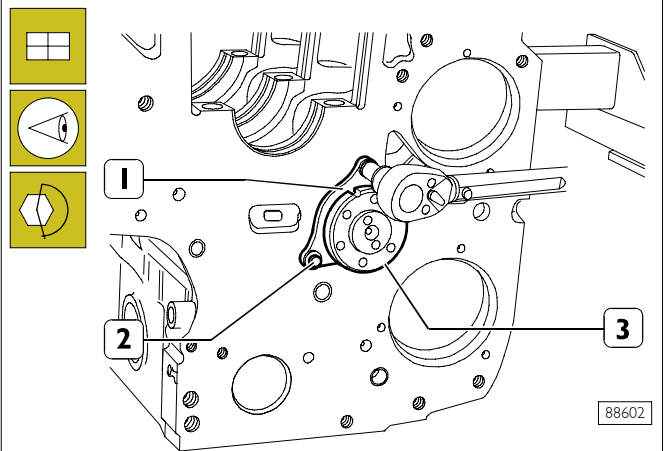
Lubricate the tappets (1) and fit them into the relevant housings on the engine block.

Figure 19



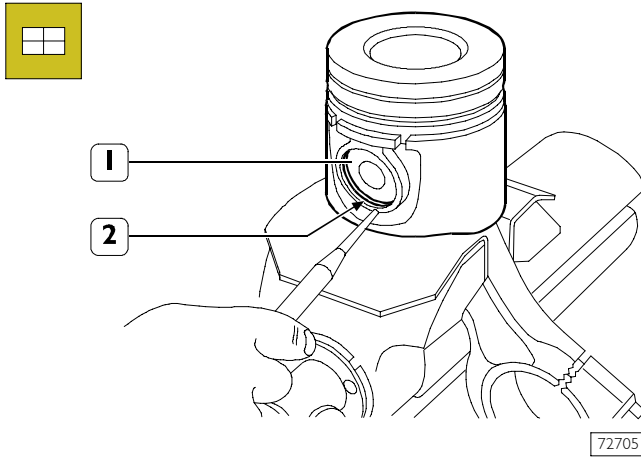
Lubricate the camshaft bush and fit the camshaft (1) taking care not to damage the bush or the housing.

Figure 20



Set camshaft (3) retaining plate (1) with the slot facing the top of the engine block and the marking facing the operator, then tighten the screws (2) to the specified torque.

Figure 52

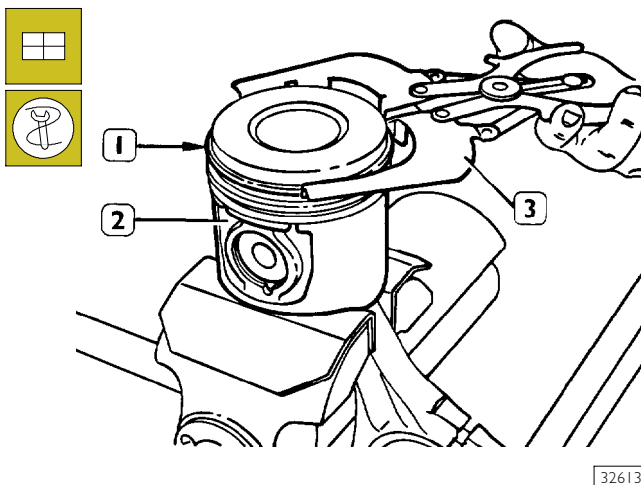


Position the piston (1) on the connecting rod according to the diagram shown in the figure, fit the pin (3) and stop it by the split rings (2).

72705

Fitting split rings

Figure 53



Use pliers 380000221 (3) to fit the split rings (1) on the piston (2).

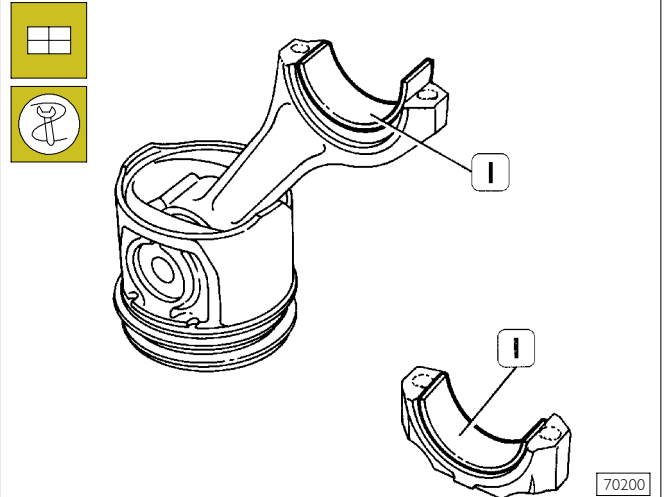
Split rings shall be fitted with the marking "TOP" facing upwards and their openings shall be displaced with each other by 120°.

32613

NOTE Split rings are supplied spare with the following sizes:

- standard;
- 0.4 mm oversize.

Figure 54



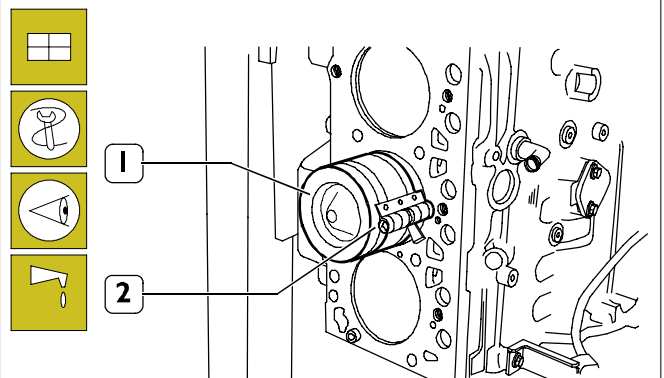
Fit half bearings (1) on connecting rod and cap.

70200

NOTE Refit the main bearings that have not been replaced, in the same position found at removal. Do not try to adapt the half bearings.

Fitting connecting rod-piston assembly into cylinder barrels

Figure 55



Lubricate accurately the pistons, including the split rings and the cylinder barrel inside.

Use band 380000220 (2) to fit the connecting rod-piston assembly (1) into the cylinder barrels and check the following:

- the number of each connecting rod shall correspond to the cap coupling number.

70201

TIGHTENING TORQUE

COMPONENT	TORQUE		
	Nm	kgm	
Bench fixing screws:	1 st step	50 ± 6	5 ± 0.6
	2 nd step	80 ± 6	8 ± 0.6
	3 rd step	90° ± 5°	
Connecting rod cap:	1 st step	30 ± 3	3 ± 0.3
	2 nd step	60 ± 5	6 ± 0.5
	3 rd step	60° ± 5°	
Engine cover fixing nuts (M8x125)	25 ± 5	2.5 ± 0.5	
Engine flywheel fixing screws:	1 st step	30 ± 4	3 ± 0.4
	2 nd step	60° ± 5°	
Pulleys and dampener fixing screws	110 ± 5	11 ± 0.5	
Screws used to fix the injectors on the cylinder heads	110 ± 5	11 ± 0.5	
P.A.P. gear fixing nut:	105 ± 7	10.5 ± 0.7	
Compressor gear fixing nut:	125 ± 19	12.5 ± 1.9	
Distribution gear fixing screws:	36 ± 4	3.6 ± 0.4	
Piston lubricating nozzle fixing unions:	15 ± 3	1.5 ± 0.3	
Distribution box fixing screws	M8 1.25x40	24 ± 4	2.4 ± 0.4
	M10 1.5x30	47 ± 5	4.7 ± 0.5
Front cover fixing screws	24 ± 4	2.4 ± 0.4	
Bench cap fixing screws M12x1.50	1 st step	50 ± 6	5.0 ± 0.6
	2 nd step	80 ± 6	8.0 ± 0.6
	3 rd step	+ 90° ± 5°	
Ladder Frame fixing screws M10 1.5x25	43 ± 5	4.3 ± 0.5	
Hoisting bracket fixing screws:	M12 1.75x25	70 ± 12	7 ± 1.2
	M10	43 ± 5	4.3 ± 0.5
Heat exchanger fixing screws	M8 1.25x35	25 ± 5	2.5 ± 0.5
	M8 1.25x100	25 ± 5	2.5 ± 0.5
	M12 Connector	25 ± 5	2.5 ± 0.5
M8 valve cap fixing screws	24 ± 4	2.4 ± 0.4	
Engine exhaust fixing (Ccv)	M8 1.25x45	24 ± 4	2.4 ± 0.4
	M8 1.25x35	24 ± 4	2.4 ± 0.4
Oil sump fixing screws	50 ± 5	5 ± 0.5	
Screws No. 26-23 M10 1.5x45	70 ± 5	7 ± 0.5	
Screws No. 3+10; 13+20; 24-25 M10 1.5x90	70 ± 5	7 ± 0.5	
Screws No. 1-2-21-22 M10 1.5x125	70 ± 5	7 ± 0.5	
Screws No. 11-12 M10 1.5x190	70 ± 5	7 ± 0.5	
Screws / Caps on Head	1/2" Nptf	24 ± 4	2.4 ± 0.4
	3/4" Nptf	36 ± 5	3.6 ± 0.5
	1/4 Inch Nptf	12 ± 2	1.2 ± 0.2
Cylinder head fixing screws	Screws No. 16-15-8-7-1-2-9-10-17-18 M12 1.75x150	55 ± 5	5.5 ± 0.5
	Screws No. 12-11-4-3-5-6-13-14 M12 1.75x130	35 ± 5	3.5 ± 0.5
Angle closure	+ 90° ± 5° + 180° ± 5°		
M6 heater grid fixing screws	10 ± 2	1.0 ± 2	
Intake manifold fixing screws:	M8 1.25x25	25 ± 5	2.5 ± 0.5
	M8 1.25x60	25 ± 5	2.5 ± 0.5

Appendix

	Page
SAFETY PRESCRIPTIONS	3
<input type="checkbox"/> Standard safety prescriptions	3
<input type="checkbox"/> Prevention of injury	3
<input type="checkbox"/> During maintenance	3
<input type="checkbox"/> Respect of the Environment	4

LUBRICATION

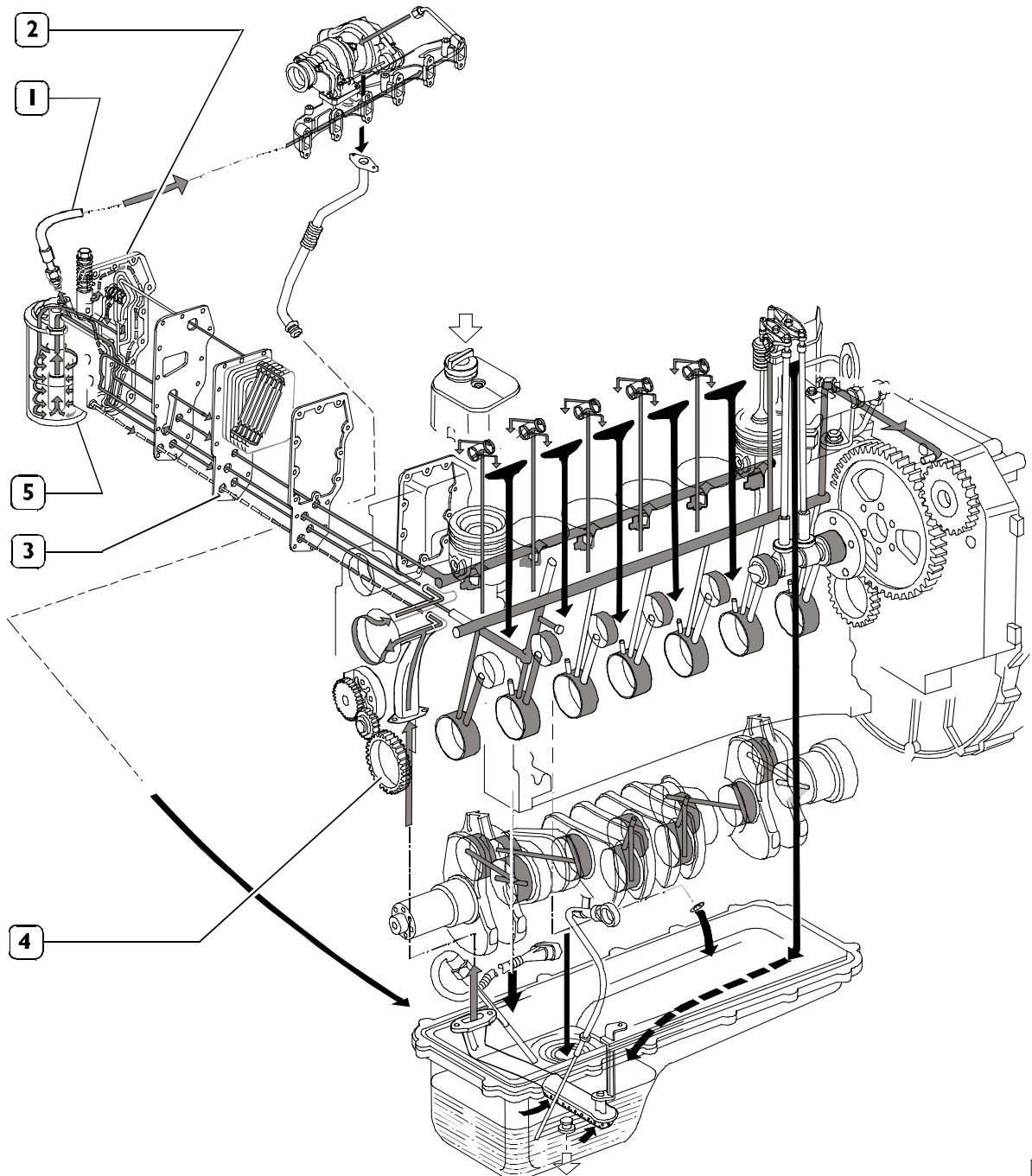
Lubrication by forced circulation is achieved through oil rotary expansion pump, placed in the front part of the basement, driven by the straight-tooth gear splined to the shaft's bar hold.

From the pan, the lubrication oil flows to the driving shaft, to the camshaft and to the valve drive.

Lubrication involves the heat exchanger (2,3), the turboblower for turbocompressed versions, and for any compressed air system.

All these components may often vary according to the specific duty.

Figure 1



LUBRICATION SYSTEM LAYOUT

1. Lubrication oil pipe to supercharger - 2. Heat exchanger body - 3. Heat exchanger - 4. Oil rotary expansion pump - 5. Oil filter.

FEED PUMP

The rotary type pump is driven by a gear mating the camshaft's one.

Example of identification

V = Distribution rotary plunger

E = Pump dimensions

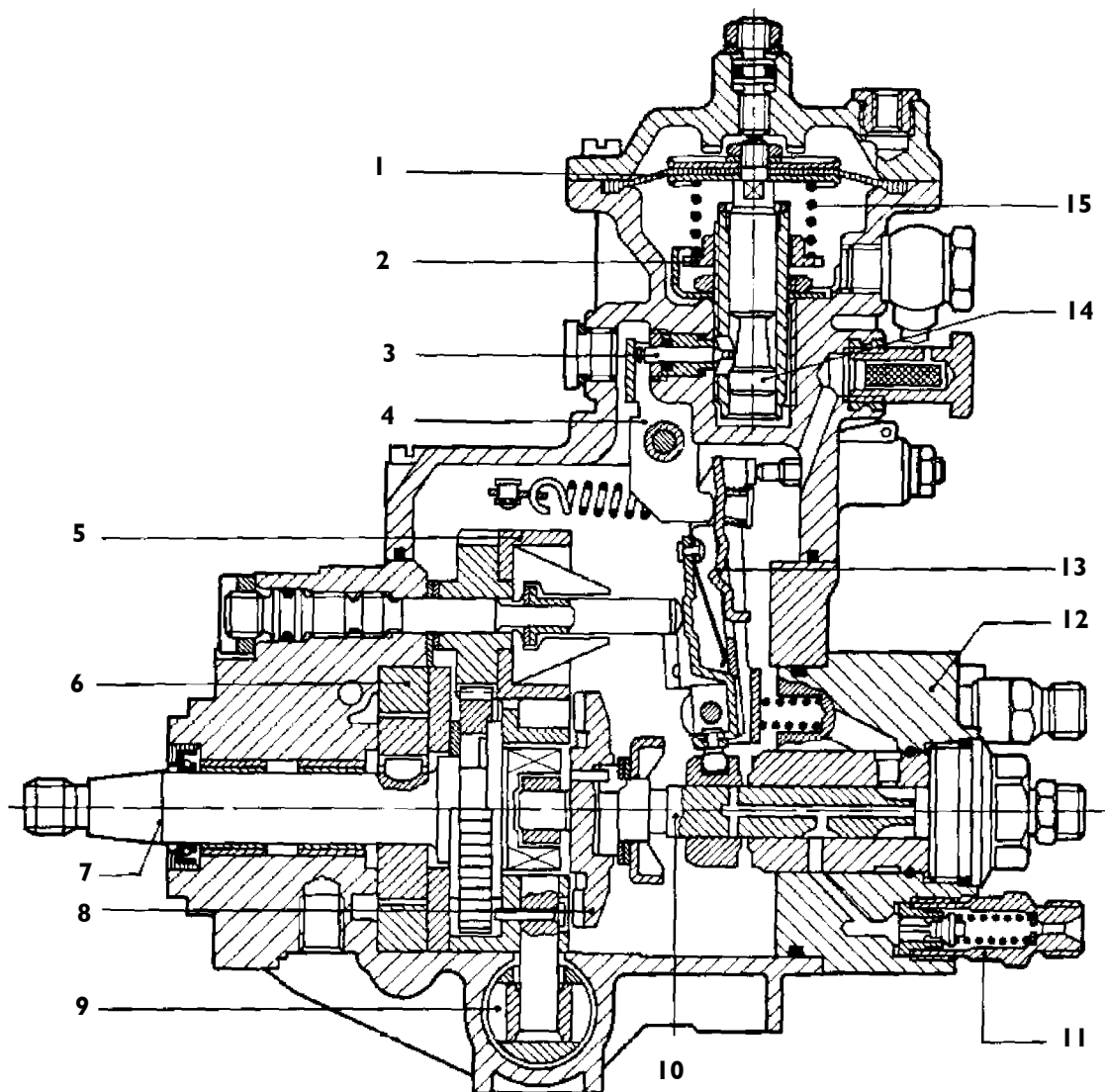
4 = 4 cylinders engine

12 = Distribution plunger in mm.

1150 = N°. of pump revolutions per minute

LV = Left direction of rotation

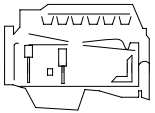
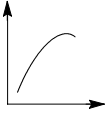

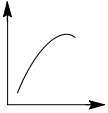



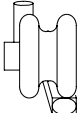


Figure 3



Injection pump longitudinal section

1. Diagram - 2. Locking nut - 3. Pivot - 4. Drive lever - 5. Speed gauge - 6. Transfer pump - 7. Drive shaft - 8. Cam disk - 9. Advance converter - 10. Distribution plunger - 11. Delivery pipe fitting - 12. Hydraulic head - 13. Drive plate - 14. Gauge pin - 15. Counteracting spring.

6-cylinder engines

	Type	F4GE9684D*J600
Q	Compression ratio	17.5:1
 	Max. output kW (HP) rpm	107 (145) 2300
 	Max. torque Nm (kgm) rpm	620 (63) 1300
	Loadless engine idling rpm	-
	Loadless engine peak rpm rpm	-
	Bore x stroke Displacement	mm cm ³ 104 X 132 6728
	SUPERCHARGING Turbocharger type	with intercooler HOLSET HX35
	LUBRICATION Oil pressure (warm engine) - idling - peak rpm	Forced by gear pump, relief valve single action oil filter bar bar 0.70 3.50
	COOLING Water pump control Thermostat - start of opening °C	By centrifugal pump, regulating thermostat, heat exchanger, intercooler Through belt 81 ± 2
 15W40 ACEA E3	FILLING engine sump* engine sump + filter* * First filling operation	liters liters - -

NOTE Data, features and performances are valid only if the setter fully complies with all the installation prescriptions provided by CNH.

Furthermore, the users assembled by the setter shall always be in conformance to couple, power and number of turns based on which the engine has been designed.

OVERHAUL OF THE 6 CYLINDER ENGINE PROVIDED WITH MECHANICAL ROTARY PUMP

Preface

Part of the operations illustrated within this section can be partially executed while the engine is assembled on the vehicle, depending on the room available for access to the engine and on the equipment application as well.

NOTE With regard to the engine disassembly operations, please apply for information consulting the specific manual. All operations of engine disassembly operations as well as overhaul operations must be executed by qualified engineers provided with the specific tooling and equipment required.

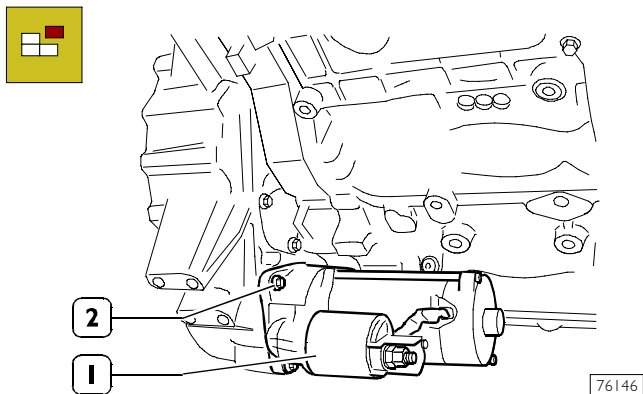
The following information relate to the engine overhaul operations only for what concerns the different components customising the engine, according to its specific duties.

NOTE For specific application exigencies, some units can be assembled to the engine in different positions.

Within "General overhaul" section, all the operations of engine block overhaul have been contemplated. Therefore the above mentioned section is to be considered as following the part hereby described.

Engine setting operations for the assembly on turning stand

Figure 2

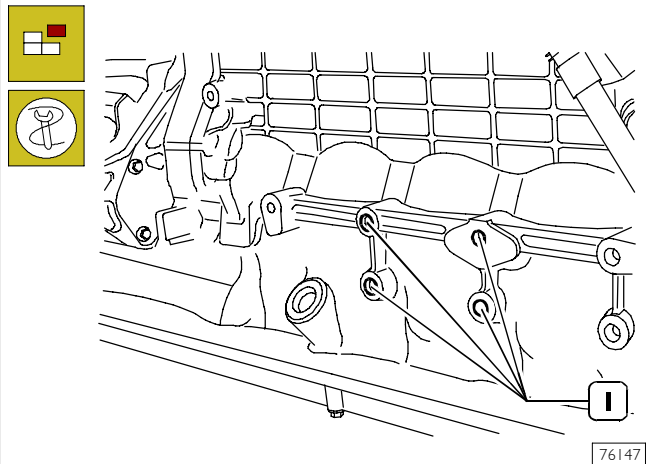


In order to apply to the engine crankcase, the engine fixing brackets 380000661 to trestle 380000301 and to carry out an adequate revision, proceed in the following manner.

From the left-hand side:

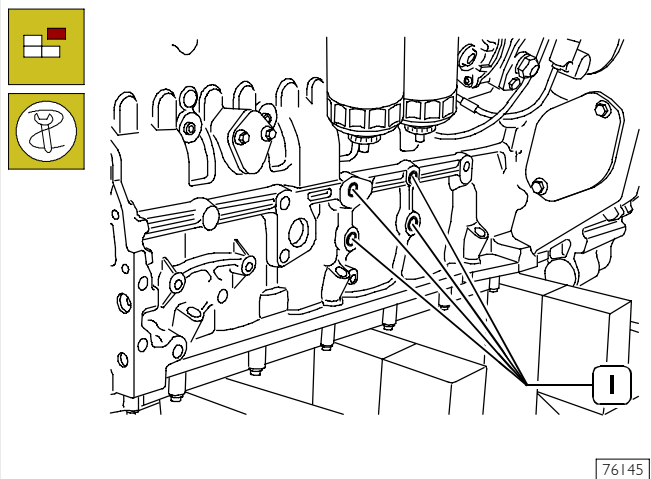
- Disassemble the starting engine (1); opportunely support the starting engine (1) and unscrew the fastening screws (2).

Figure 3



- Assemble the bracket bearing 380000661 using the four screw threaded ports (1).

Figure 4



- Assemble the second bracket 380000661 throughout the screw-threaded ports (1).
- Lift the engine using the rocker arm 380000216 and put it on the turning stand 380000301.
- Drain the oil through the cap underneath the plug.

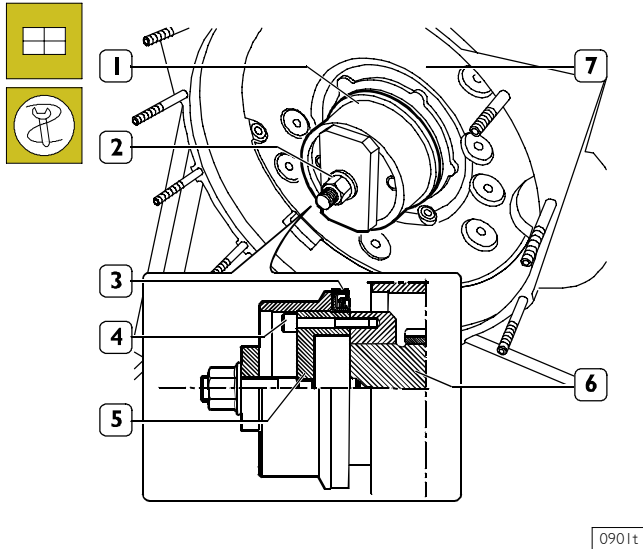


Warning: avoid contact of engine oil with the skin: in case of skin contamination, rinse in running water.



Engine oil is highly pollutant: provide for disposal in compliance with the law and regulations in force.

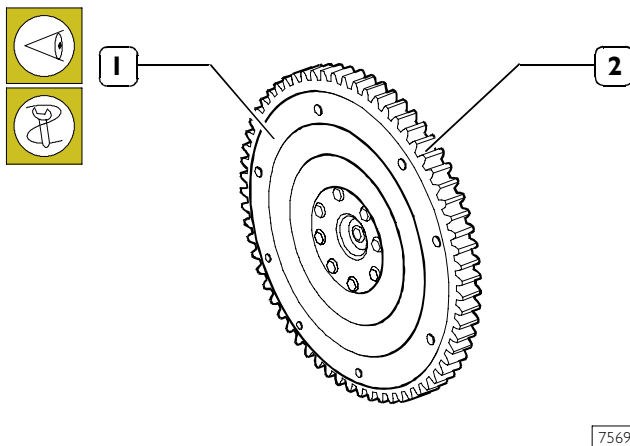
Figure 40



0901t

- Apply to engine drive shaft rear tang (6), the detail (5) of the tool 380000666, fix it tightening the screws (4) and key the new holding ring on it (3).
- Place detail (1) on detail (5), tighten the screw nut (2) until complete assembly of the fixing ring (3) into the flywheel cover box (7).

Figure 41

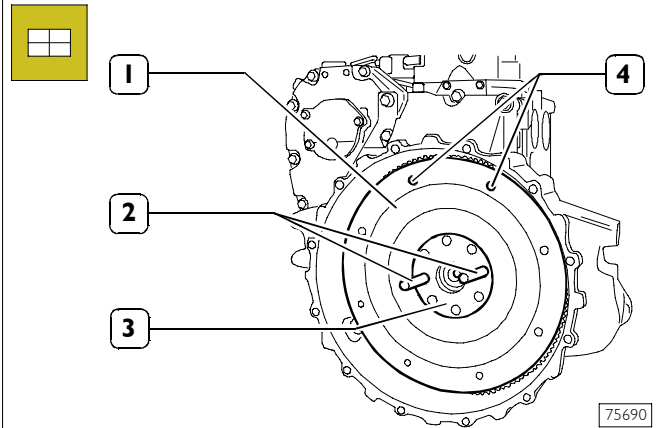


75696

- Check the contact surface (1) of the clutch plate and if it is scratched, proceed with turning.
- Check ring gear teeth (2), if breakage or excessive wear is found remove the ring gear from the engine flywheel (1) using a suitable hammer and fit the new one, previously heated to 150°C for 15 to 20 minutes. Chamfering on ring gear inside diameter shall be facing the engine flywheel.

Flywheel installation

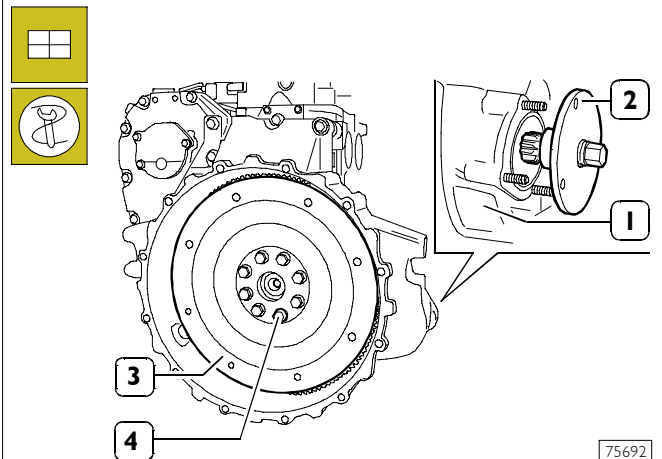
Figure 42



75690

- Screw up two hooks or trail rings in the flywheel (1) threaded ports (4) for handling .
- Using a hoist, handle the flywheel to place it in its housing inside the flywheel cover box.
- Screw up to pins (2) having appropriate length, in the shaft ports (3) and using them as guide, assemble the engine flywheel (1) properly placing it inside the flywheel cover box.

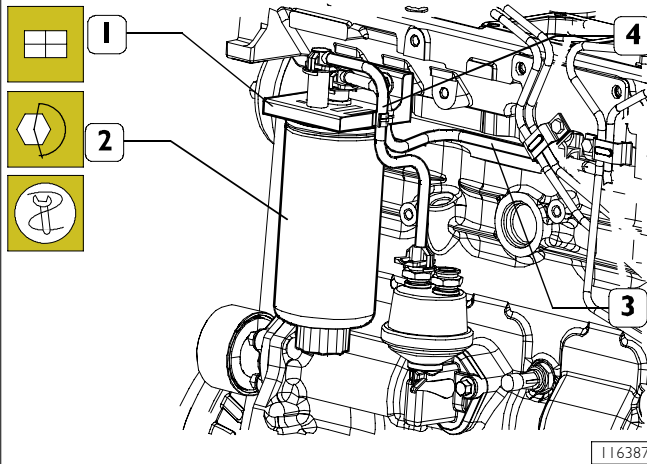
Figure 43



75692

- Tighten the screws (4) fixing the engine flywheel (3) to the engine shaft. Use tool 380000988 (2) to operate on the flywheel cover box (1) to block engine flywheel rotation.

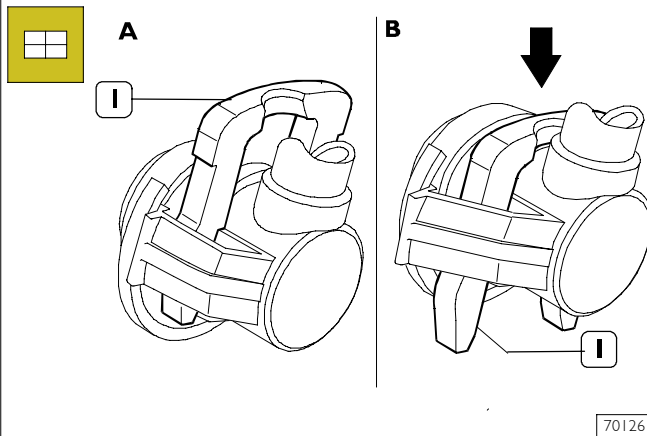
Figure 83



- Assemble the fuel filter bearing (1) to the bracket fixed to the engine head.
- Connect the fuel pipelines (4 and 3) respectively from priming pump to filter bearing and from this last one to feed pump.
- Using 380000670 equipment assemble fuel filter (2).

NOTE The filter shall be priory filled with fuel to facilitate feed system bleed operations.

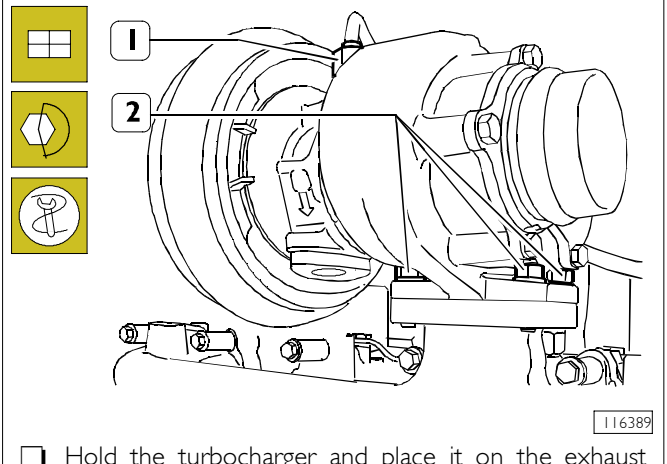
Figure 84



NOTE To connect fuel pipelines (3 and 4, Figure 83) in low pressure from the relating connection unions it is necessary to press the locking fastener (1) as shown in picture B.

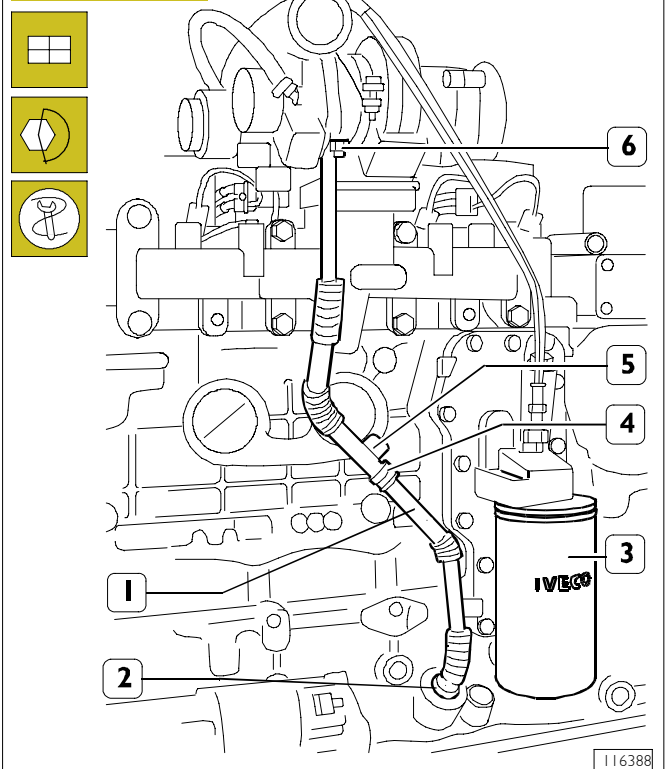
After having connected the pipeline, reset the fastener (1) into block position as shown in picture A.

Figure 85



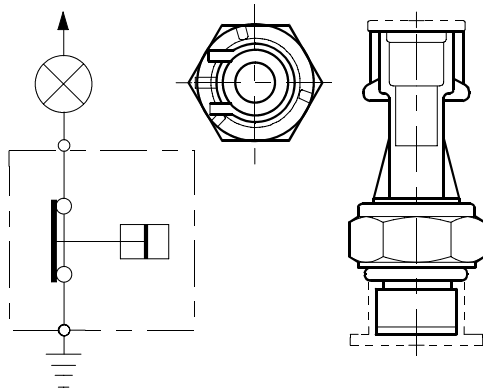
- Hold the turbocharger and place it on the exhaust manifold after having interposed the gasket.
- Screw up the fixing nuts (2) of the turbocharger to the exhaust manifold tightening them to the prescribed couple.
- Tighten the lubrication pipe fixing ring (1). Operate in the same way on the other end of the pipe. Connect it to the upper part of the heat exchanger.

Figure 86



Assemble the lubricating oil discharge pipe (1) coming from the turbo-blower:

- Insert the junction (2) into the engine crankcase;
- Tighten the two screws (6) underneath the turbo-blower;
- Tighten the screw (5) which holds the piping to the monoblock by means of the cylinder bracket (4).
- Assemble the oil filter using tool 380000670 (3).

Oil pressure sensor**Figure 105**

75722

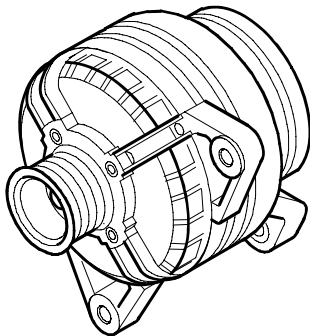
It is assembled to the block on the engine's left hand side.

Specifications:

Working tensions: 12 ÷ 24 V

Contact closure
upon lower pressure: 0.2 bar

Contact opening
upon higher pressure: 0.9 bar

Alternator**Figure 106**

75725

It is place front view on the right hand side of the engine, and is driven by tooth belt.

Engines F4GE9684B*J601, F4GE9684C*J600,
F4GE9684D*J600

Specifications:

Rated tensions: 14 V

Current delivered: 120A (at 4000 rpm)

Absorption in stand-by: ≤ 1mA

Sense of rotation: clockwices

Engines F4GE9684E, F4GE9684F, F4GE9684G

Specifications:

Rated tensions: 28 V

Current delivered: 70A (at 6000 rpm)

Absorption in stand-by: ≤ 1mA

Sense of rotation: clockwices

Engines F4GE968R

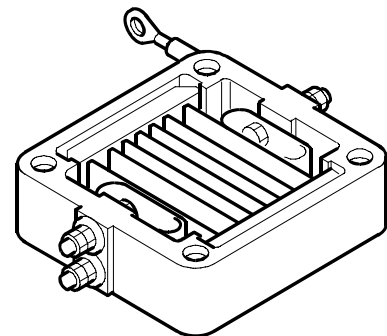
Specifications:

Rated tensions: 14 V

Current delivered: 120A (at 6000 rpm)

Absorption in stand-by: -

Sense of rotation: clockwices

Pre-post heating resistor (where provided)**Figure 107**

75723

It is a resistor assembled to the suction collector and is utilised to heat the air during pre-post heating operations.

It is fed by a tele-switch usually placed very close to the engine.

Specifications:

Working tension: 24 V

Maximum possible
air flow: 2 cc / min
(pressure 138 kPa)

PART FOUR - MAINTENANCE PLANNING

GENERAL SPECIFICATIONS

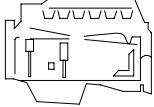
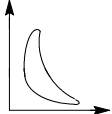
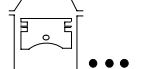
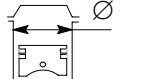
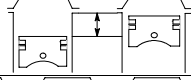

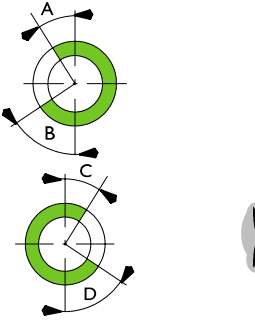


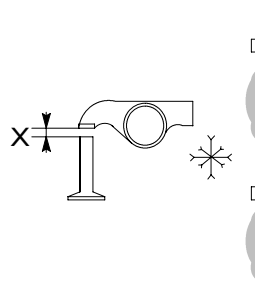




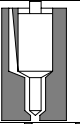
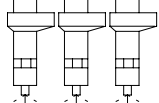
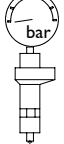
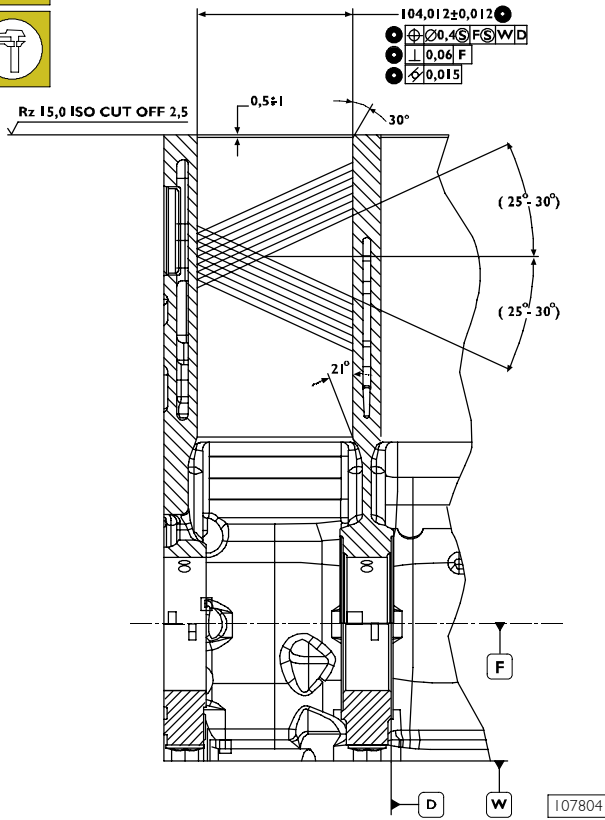
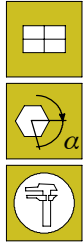
	Type	6 CYLINDERS
	Cycle	Four-stroke diesel engine
	Power	See properties described in Section 3
	Injection	Direct
	Number of cylinders	6 in-line
	Bore mm	104
	Stroke mm	132
	Total displacement cm ³	6728
	<p>TIMING</p> <p>  start before T.D.C. A end after B.D.C. B </p> <p>  start before B.D.C. D end after T.D.C. C </p>	<p>-</p> <p>-</p> <p>-</p> <p>-</p>
	<p>Checking timing</p> <p>  × { mm  × { mm </p> <p>Checking operation</p> <p>  × { mm  × { mm </p>	<p>-</p> <p>-</p> <p>0.25 ± 0.05</p> <p>0.50 ± 0.05</p>
<p>FUEL FEED</p>		
	Type: rotary Bosch	VE 6/12 F
	Nozzle type	-
	Injection sequence	1 - 5 - 3 - 6 - 2 - 4
	Injection pressure bar	-

Figure 11



NOTE In case of regrinding, all barrels shall have the same oversize (0.4 mm).

Check main bearing housings as follows:

- fit the main bearings caps on the supports without bearings;
- tighten the fastening screws to the specified torque;
- use the proper internal gauge to check whether the housing diameter is falling within the specified value.

Replace if higher value is found.

Checking head supporting surface on cylinder unit

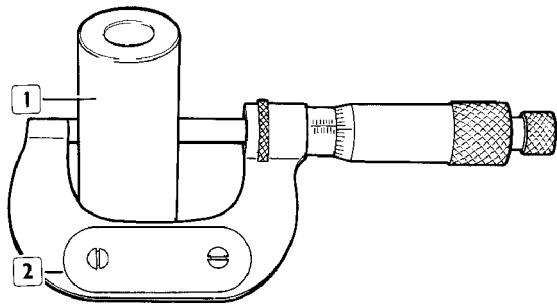
When finding the distortion areas, replace the cylinder unit.

Planarity error shall not exceed 0.075 mm.

Check cylinder unit operating plug conditions, replace them in case of uncertain seal or if rusted.

Piston pins

Figure 41

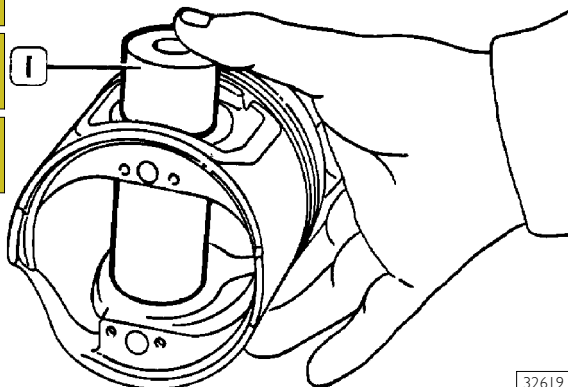


18857

To measure the piston pin (1) diameter use the micrometer (2).

Conditions for proper pin-piston coupling

Figure 42

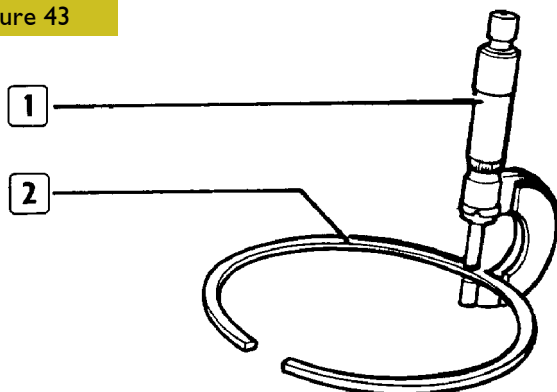


32619

Lubricate the pin (1) and its seat on piston hubs with engine oil; the pin shall be fitted into the piston with a slight finger pressure and shall not be withdrawn by gravity.

Split rings

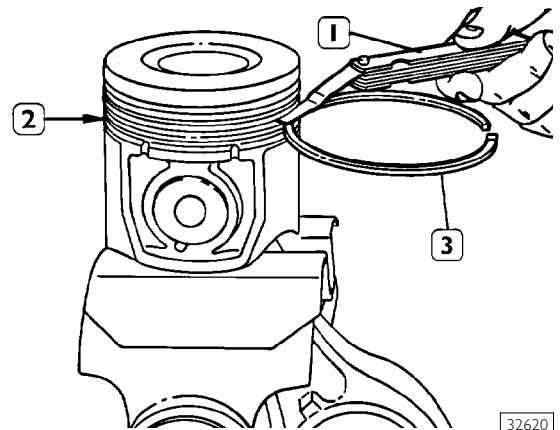
Figure 43



16552

Use a micrometer (1) to check split ring (2) thickness.

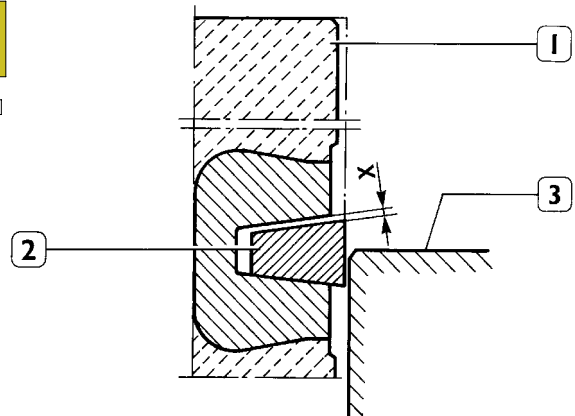
Figure 44



32620

Check the clearance between the sealing rings (3) of the 2nd and 3rd slot and the relevant housings on the piston (2), using a feeler gauge (1).

Figure 45



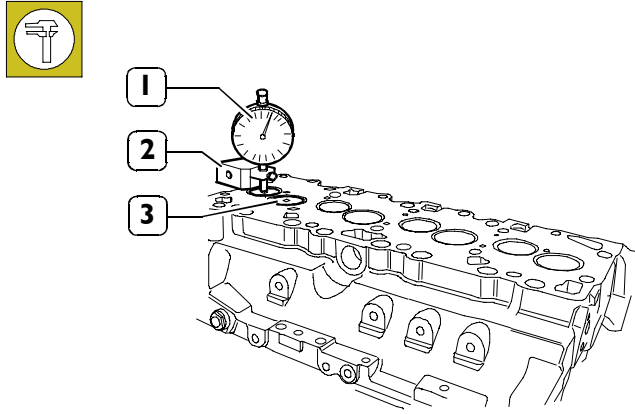
41104

DIAGRAM FOR MEASURING THE CLEARANCE X BETWEEN THE FIRST PISTON SLOT AND THE TRAPEZOIDAL RING

Since the first sealing ring section is trapezoidal, the clearance between the slot and the ring shall be measured as follows: make the piston (1) protrude from the engine block so that the ring (2) protrudes half-way from the cylinder barrel (3).

In this position, use a feeler gauge to check the clearance (X) between ring and slot: found value shall be the specified one.

Figure 74

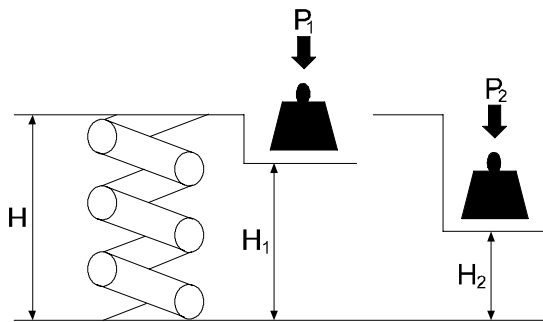


75758

After regrounding, check that valve (3) sinking value is the specified one by using the base 380000364 (2) and the dial gauge 380000228 (1).

VALVE SPRINGS

Figure 75



50676

MAIN DATA TO CHECK INTAKE AND EXHAUST VALVE SPRINGS

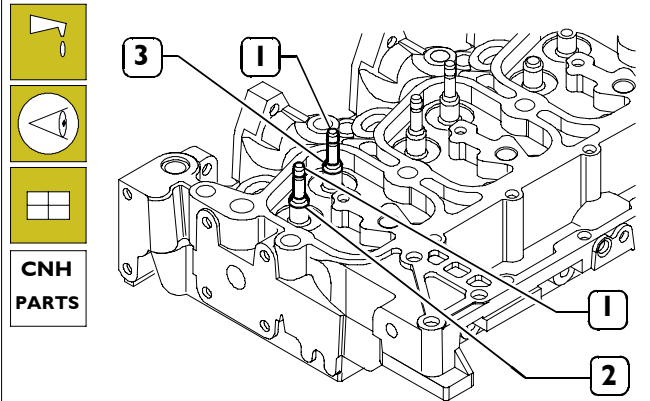
Before refitting use adequate tool to check spring flexibility. Compare load and elastic deformation data with those of the new springs shown in the following table.

Height	Under a load of	
mm	N	
H (free)	63.50*/63.69	0
H ₁	49.02	329
H ₂	38.20	641

* Engine F4GE9684B
F4GE9684R
F4GE9684G

FITTING CYLINDER HEAD

Figure 76



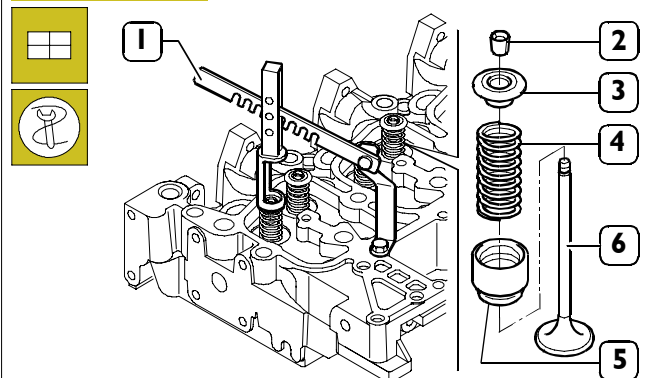
75759

Lubricate the valve stems (1) and fit them into the relevant valve guides according to the position marked at removal.

Fit the sealing rings (2 and 3) on the valve guide.

NOTE Sealing rings (2) for intake valves are yellow and sealing rings (3) for exhaust valves are green.

Figure 77



75751

Position on the cylinder head: the spring (4), the upper cap (3); use tool 380000302 (1) to compress the spring (4) and lock the parts to the valve (5) by the cotter (2).

CLICK HERE TO **DOWNLOAD** THE COMPLETE MANUAL

- Thank you very much for reading the preview of the manual.
- You can download the complete manual from: www.heydownloads.com by clicking the link below



- Please note: If there is no response to CLICKING the link, please download this PDF first and then click on it.

CLICK HERE TO **DOWNLOAD** THE COMPLETE MANUAL