

en

Operator's manual

Crawler dozer

Document ID

	ORIGINAL OPERATOR'S MANUAL
Order number:	93517588
Issued:	01.01.2021
Version:	02
Author:	LWT / Technical Documentation Department

Product ID

Manufacturer:	Liebherr-Werk Telfs GmbH
Type:	PR 766
Type no.:	1681 05_G8.0, 1681 4F_G8.0 (USA / CAN)
From Serial no.:	18190

Contact

Liebherr-Werk Telfs GmbH
Hans Liebherr-Straße 35
A – 6410 Telfs

CLICK HERE TO **DOWNLOAD** THE COMPLETE MANUAL

- Thank you very much for reading the preview of the manual.
- You can download the complete manual from: www.heydownloads.com by clicking the link below



- Please note: If there is no response to CLICKING the link, please download this PDF first and then click on it.

CLICK HERE TO **DOWNLOAD** THE COMPLETE MANUAL

3.7.2	Towing the machine	233
3.7.3	Jump start procedure	242
4	Operating problems	245
4.1	Servicecodes	245
4.1.1	Service code - Display unit	245
4.2	Problems - Cause - Remedy	247
4.2.1	Diesel engine	247
4.2.2	Hydraulic system	252
4.2.3	Undercarriage	253
4.2.4	Electrical system	253
4.2.5	Heating	253
4.2.6	Working attachment	254
4.2.7	Electronic immobiliser (option)	254
4.2.8	Central lubrication system (option)	254
4.3	Problem remedy	256
4.3.1	Changing fuses	256
5	Maintenance	265
5.1	Maintenance and inspection schedule	265
5.2	Fill quantities and lubrication chart	271
5.2.1	Recommended lubricants	271
5.2.2	Recommended fuel and operating fluids	272
5.2.3	Lubrication chart	272
5.2.4	Symbols in the lubrication chart	274
5.3	Lubricants and fuels	275
5.3.1	General information about lubricants and fuels	275
5.3.2	Diesel fuels	275
5.3.3	Engine oils	276
5.3.4	Coolant	278
5.3.5	Diesel exhaust fluids	279
5.3.6	Hydraulic oils	280
5.3.7	Lube oils for splitterboxes	281
5.3.8	Lube oils for travel gearbox	282
5.3.9	Oil for duo cone (slipring) seal Travel gear	284

- Can be adjusted to the operator

1.2.9 Undercarriage

Design: undercarriage with oscillating track rollers and idlers

Bearing: support axles and equaliser bar

Tracks: oil-lubricated, single grouser track pads, track tension by means of spring tensioner and grease tension cylinder

Description	Unit	Value
Track links per side		43
Track rollers per side		8
Carrier rollers per side (option)		1
Sprocket segments per side		5
Track pads (standard)	ft-in	2'
Track pads (option)	ft-in	2' 2"
Track pads (option)	ft-in	2' 4"
Track pads (option)	ft-in	2' 6"

1.2.10 Pull force

Description	Unit	Value
Maximum	lb _r	156,020
At 1 mph	lb _r	137,580
At 2 mph	lb _r	71,490
At 4 mph	lb _r	35,300
At 6 mph	lb _r	23,830

1.2.11 Basic machine dimensions

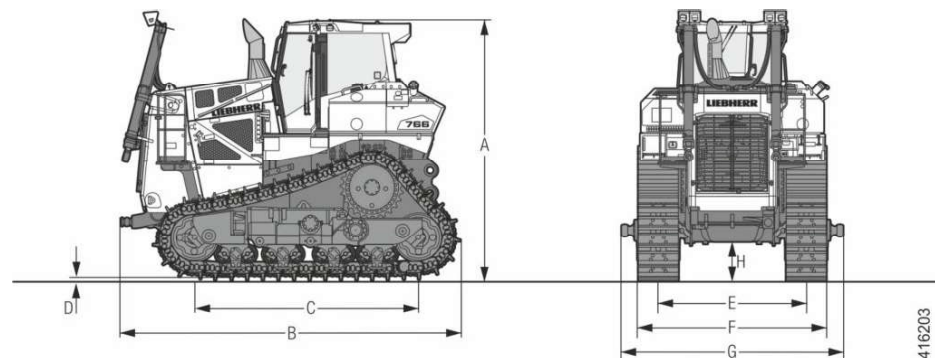

Fig. 3: Basic machine dimensions

Metric standard thread and fine thread				Metric standard thread and fine thread							
At least one element of the screwed connection (screws, washers, nuts, ...) with following surface: flZn = zinc coating (LH standard 10021432, LH standard 10215295 flZnnc-480h-L valid ≥M6)				All elements of the screwed connection (screws, washers, nuts, ...) with following surface: black oxide or phosphated zinc plated (LH standard 10215295 Fe//ZnNi(12)5//Cn//T2)							
Minimum total coefficient of friction $\mu_G = 0.09$				Minimum total coefficient of friction $\mu_G = 0.11$							
Thread	Grade	Assembly prestressing forces F_M in lb_f	Tightening torques M_A in ft-lb	Thread	Grade	Assembly prestressing forces F_M in lb_f	Tightening torques M_A in ft-lb				
				M 4	8.8	1,010	2				
					10.9	1,480	3				
					12.9	1,730	4				
								M 5	8.8	1,640	4
									10.9	2,410	6
									12.9	2,810	7
M 6				M 6	8.8	2,320	7				
					10.9	3,420	11				
					12.9	3,980	12				
M 7				M 7	8.8	3,370	12				
					10.9	4,950	17				
					12.9	5,850	21				
M 8				M 8	8.8	4,250	18				
					10.9	6,290	26				
					12.9	7,190	30				
M 8 x 1				M 8 x 1	8.8	4,610	18				
					10.9	6,740	27				
					12.9	7,870	32				
M 9 x 1				M 9 x 1	8.8	6,070	27				
					10.9	8,770	39				
					12.9	10,340	46				
M 10				M 10	8.8	6,740	35				
					10.9	9,890	50				
					12.9	11,690	59				
M 10 x 1				M 10 x 1	8.8	7,640	38				
					10.9	11,240	55				
					12.9	13,260	65				

LWT193517568/02/01_01_2021/en

The operator may only carry out work with the crawler tractor if there are no persons in the hazard zone.

In the event of danger to persons, the operator must stop the dangerous movement and give warning signs.

The operator must give warning signs (e.g. sounding the horn, light signals) in the event of danger to persons.

The operator must suspend operation if persons do not leave the hazard zone despite the warning.

The operator may only swing the work equipment over occupied operator platforms, operating stations and work stations of other equipment if these areas are secured against work equipment or loads falling by means of resistant protective roofs.

2.3.5 Operating conditions

Temperature range (ambient temperature)	-8 °F to 113 °F
---	-----------------

Tab. 16: Operating conditions

Danger to life

Operation in the event of thunderstorms or bad weather

- If possible, suspend operation prior to the onset of a thunderstorm or bad weather.
- Put the working attachment down on the ground as flat as possible.
- Properly secure the machine.
- Close the windows.
- Turn diesel engine off.
- Set the starting switch to **0**.
- Make sure there is nobody in the area around machine.

Lightning strike

- Remain in the operator's cab.
- Do not leave the machine until all components are de-energised.



Contact with high voltage wiring

- Do not move the machine or working attachment.
- Remain in the operator's cab.
- Do not leave the machine until all components are de-energised.
- Ensure that all persons keep their distance from the machine and the high voltage wiring.
- Allow the voltage to shut down.

Damage

Improper operation if operating conditions deviate from the intended use

- Equip the machine according to the operating conditions.

	Safety sign	Meaning
5		<p>ROPS/FOPS</p> <p>Warns of risk of accidents potentially resulting in death or very severe injuries. Structural changes (such as welding, drilling) on the ROPS/FOPS operator's cab are not permitted without prior consultation with Liebherr customer service.</p>
6		<p>Downhill travel</p> <p>Warns of risk of accidents potentially resulting in death or very severe injuries. Always adapt the travel speed to the working conditions. When driving downhill, drive only at low travel speed.</p>

Tab. 18: Safety signs in the operator's cab

2.5.2 Information signs

Information signs denote specific points relating to the operation, maintenance and characteristics of the machine.

NOTICE

Non-observance of the information signs!
Damage to machine.

- ▶ Observe the information signs.
 - ▶ Check the condition of the information signs regularly.
 - ▶ Replace incomplete, illegible or missing information signs immediately.
-

10. Carefully check out transport route beforehand, especially in regards to width, height and weight limitations.
11. Check that there is enough clearance underneath all electrical lines, bridges, underpasses and in tunnels.
12. During unloading procedure, proceed with same caution as during loading procedure.
Procedure:
 - Remove all chains and wedges. Start engine as outlined in operator's manual.
 - Carefully drive off loading platform down ramp.
 - Have another person guide and signal you.

2.6.9 Safety instructions for towing machine

1. Always follow the correct procedure according to the instructions in the **operator's manual**, refer to section "Towing the machine".
2. The machine may only be towed in exceptional circumstances, for example to move the machine from a dangerous area for repair.
3. If the sun gears are removed, the machine starts to roll by itself from an incline of 2°. Before removing and installing the sun gears, secure the machine to prevent it from rolling off.
4. If the sun gears are removed, the service brake and parking brake are without function.
5. Before pulling or towing, check all towing and pull devices for safety and stability.
6. The rod, which is used to tow the machine must be adequate to pull the machine and must be connected to the appropriate bores and towing devices. Damage or accidents which occur when towing machine cannot be covered by manufacturer's guarantee under any circumstances.
7. During towing procedure, keep within required transport position, permissible speed and distance.
8. When returning machine to operation, proceed only as outlined in operator's manual.
9. After the towing procedure, re-establish the series condition of the machine.

2.6.10 Safety instructions for maintenance

1. Never perform any maintenance or repairs for which you are not qualified or you do not understand.
2. Observe stated intervals or time periods for repeat checks and inspections as outlined in operator's manual. Always use appropriate tools to carry out maintenance work.
3. Chart in this operator's manual defines exactly who must or can carry out which type of work. Operator can exclusively carry out work marked in maintenance and inspection schedule with by "maintenance staff". Remaining tasks can exclusively be carried out by specialist staff with appropriate training.
4. Spare parts must meet technical requirements set forth by manufacturer. This is always ensured by using original spare parts. Spare parts, which do not meet technical requirements of manufacturer can impact safety and function of machine.
5. Always wear safe work clothing when performing maintenance. For certain work, safety glasses and work gloves are required, in addition to a hard hat and safety shoes.
6. Keep unauthorized personnel away from machine during maintenance.
7. Secure a wide-ranging area for service, as necessary.

9. While working, it is **imperative** that following described measures be observed:
- After opening clean side of fuel system, do not use pressurized air for cleaning.
 - Remove loose dirt during installation work with a suitable suction device (industrial vacuum cleaner).
 - Use only lint-free cleaning cloths on fuel system.
 - When removing and installing components, do not use materials such as rags, cartons or wood, since they could secrete particles and fibers.
 - If paint chips are created when releasing connections (due to possible excess paint application), then remove these paint chips carefully before releasing fittings all way.
 - Close off all removed parts on clean side of fuel system **immediately** on their connection ports with suitable caps. Capping material must be packed dust-free until used and must be disposed after one-time use.
 - Store removed parts carefully in a clean, closed off container.
 - **Never** use previously used cleaning or test fluids for removed parts.
 - Remove new parts from their original packaging just immediately before use.
 - Carry out work on removed components only on a workstation which is equipped for this purpose.
 - To ship removed parts, always use original packaging of new part.

Menu bar

The menu bar is displayed permanently at the lower edge of the screen. The menu items available may be called up directly at any time independently of the screen content currently selected. A symbol highlighted in black identifies the active menu.

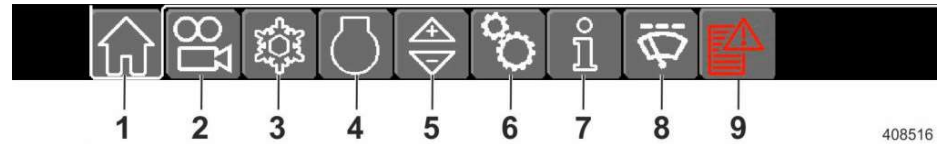

408516

Fig. 94: Menu bar

- | | | | |
|---|--|---|--------------------------|
| 1 | Main menu | 6 | Functions |
| 2 | Camera system | 7 | Information |
| 3 | Heating, ventilation, air conditioning ⁷⁾ | 8 | Windscreen wiper |
| 4 | Units ⁸⁾ | 9 | Messages (service codes) |
| 5 | Settings | | |

Main menu

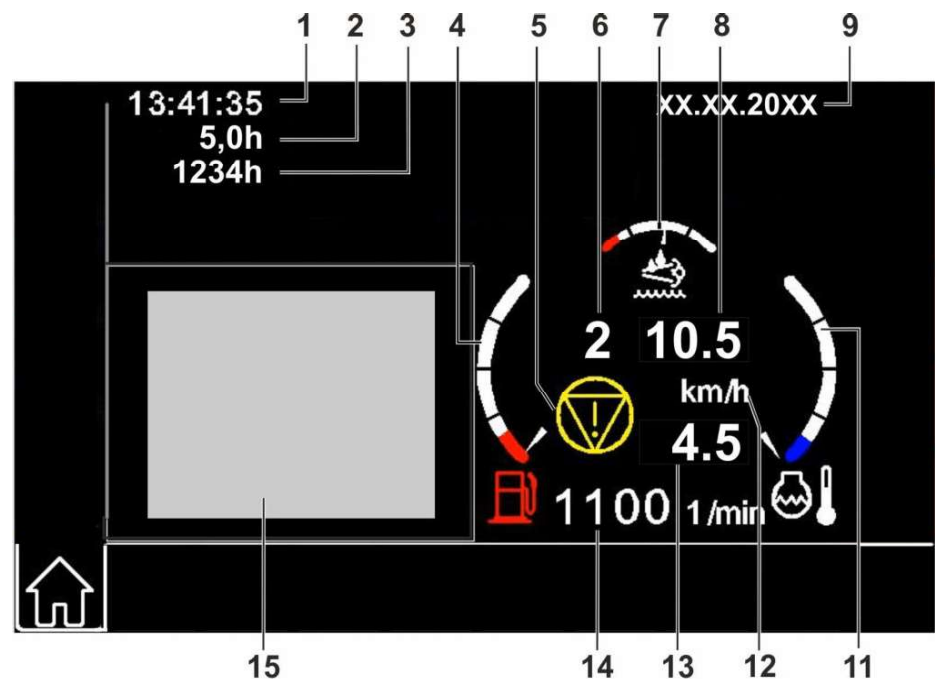

408519

Fig. 95: Main menu

- | | | | |
|---|-----------------------|----|----------------------|
| 1 | Time | 8 | Forward travel speed |
| 2 | Daily operating hours | 9 | Date |
| 3 | Operating hours | 11 | Coolant temperature |
| 4 | Fuel tank content | 12 | Speed unit |

See next page for continuation of the image legend

⁷⁾ Only PR736 to PR756

⁸⁾ Option

4 Travel gearbox - temperature monitoring¹⁸⁾

Travel gearbox, left



408341

- Display if temperature is too high in the left travel gearbox.

Travel gearbox, right



408340

- Display if temperature is too high in the right travel gearbox.

Travel gearbox left and right



408342

- Display if temperature is too high in the left and right travel gearbox.

5 Diesel engine stop



408550

- Display in the case of problems with the diesel engine or the machine. If the display lights up, turn the diesel engine off immediately and remedy the problem.

6 Diesel engine problem



408874

- Display in the case of a malfunction with the diesel engine. If the display lights up, turn the diesel engine off immediately and remedy the problem.

7, 8 Exhaust gas treatment malfunction¹⁹⁾

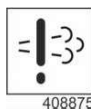

408875

- Symbol colour yellow
Display in case of malfunctions with exhaust gas treatment. If the display lights up, turn the diesel engine off immediately and remedy the problem.
- Symbol colour red
Display in case of malfunctions with exhaust gas treatment. Turn the diesel engine off immediately and remedy the problem.

9 Regeneration - exhaust gas treatment²⁰⁾

When steering and working under a low load hydrocarbons are deposited which need to be expelled after a certain period of time.

The exhaust treatment system regenerates itself automatically, when necessary, at a standstill provided that the parking switch or seat contact switch are activated.

¹⁸⁾ Except for PR716/PR726 and LR626/LR636

¹⁹⁾ Except for PR776, RL46 and RL56/RL66 emission stage IV/tier 4f

²⁰⁾ Only PR716 and LR626

Setting language

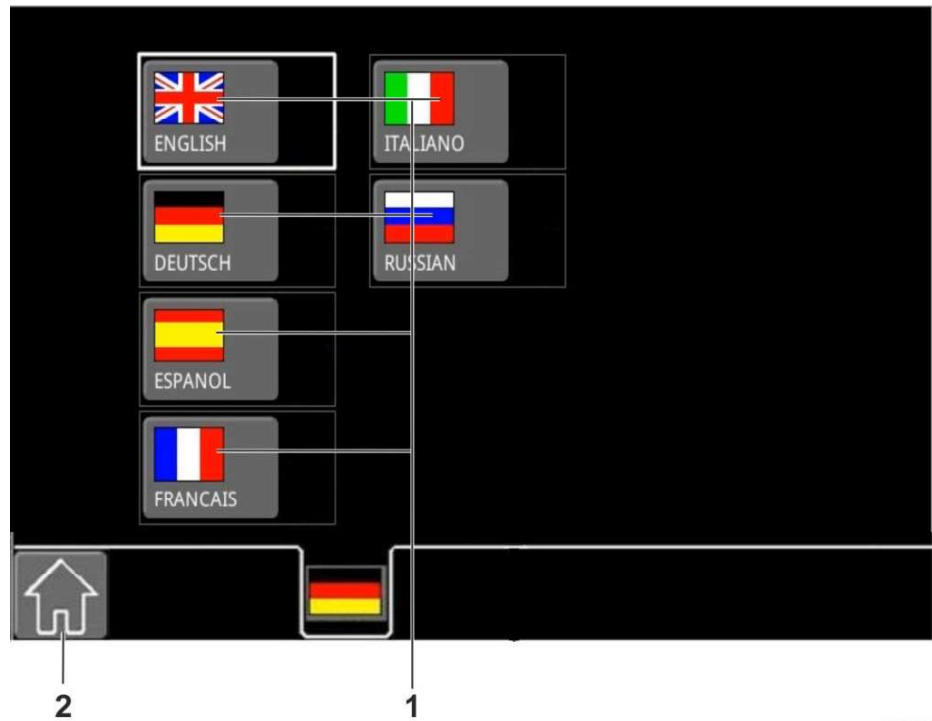

408309

Fig. 174: Setting the display language

- 1 Language selection 2 Main menu symbol
- Select the desired language via symbol 1.
 - Leave the menu via the main menu 2 symbol.

Setting reversible fan (option)

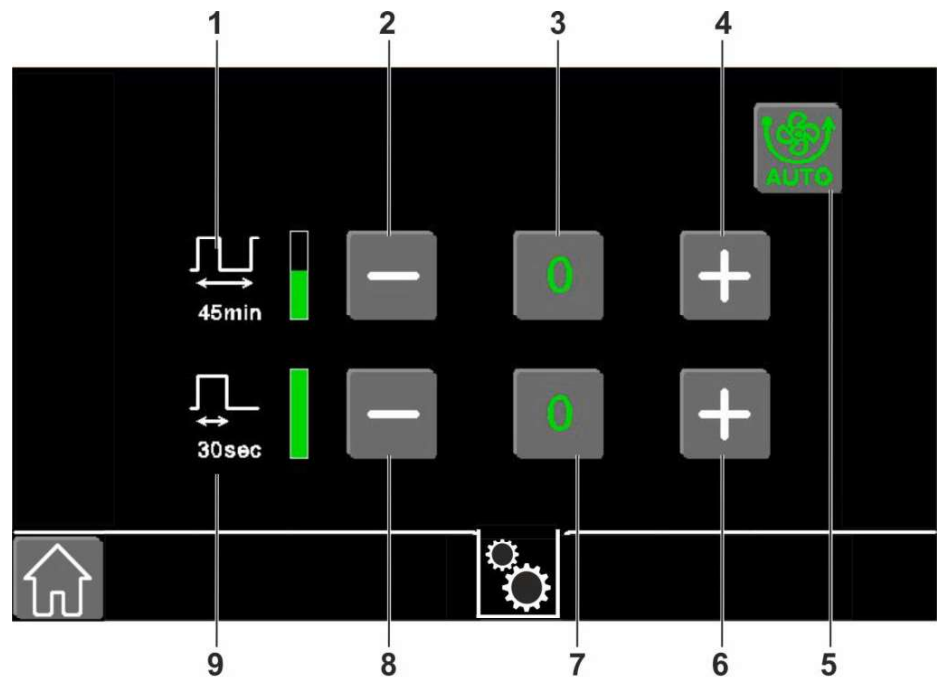

410530

Fig. 184: Setting reversible fan









- | | | | |
|---|---|---|-------------------------|
| 1 | Reverse interval | 6 | Reverse duration long |
| 2 | Reverse interval short | 7 | Reverse duration medium |
| 3 | Reverse interval medium | 8 | Reverse duration short |
| 4 | Reverse interval long | 9 | Reverse duration |
| 5 | Turn automatic reverse operating on and off | | |

The reverse interval can be shorted by 10 minutes or extended by 15 minutes.

The reverse duration can be shorted by 10 seconds or extended by 15 seconds.

– Set reverse interval and reverse duration.

By turning the reversible fan off via symbol **5**, the reversible fan and the button in the cab are deactivated.

Symbol	System status	Limitation
 414580 Diesel exhaust fluid level: yellow  414615 Warning sound	Stage 1: Diesel exhaust fluid level < 10% or malfunction of the exhaust treatment system 0 to 60 min	No limitation
 414576 Exhaust gas treatment malfunction: yellow  414580 Diesel exhaust fluid level: yellow  414615 Warning sound	Stage 2: Diesel exhaust fluid level < 5% or malfunction of the exhaust treatment system 60 to 180 min	– The performance is reduced by up to 25% via a time ramp. – Possible to move the machine out of the danger area.
 414576 Exhaust gas treatment malfunction: yellow  414581 Diesel exhaust fluid level: red  414615 Warning sound	Stage 3: Diesel exhaust fluid level < 2.5% or malfunction of the exhaust treatment system 180 to 210 min	– The performance is reduced by up to 80% via a time ramp. – No longer possible to move machine out of danger zone due to position and soil characteristics.

LWT193517568/02/01_01_2021/en

Adjust the backrest incline



Fig. 222: Adjust the backrest incline

2 Backrest inclination lever

- ▶ Pull the lever 2 up as far as it will go.
- ▶ Bring the backrest into the desired incline.
- ▶ Release the lever 2.

Adjusting the seat heater and seat climate control²⁸⁾

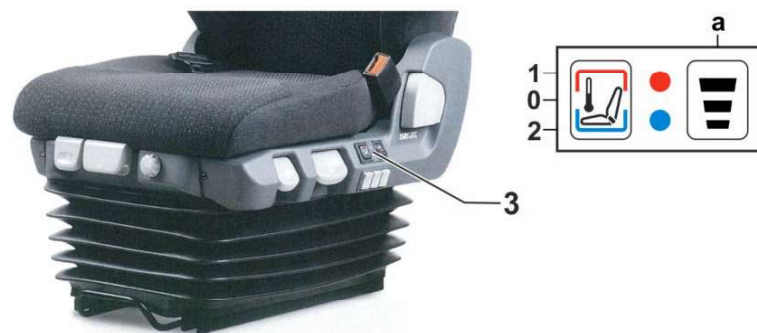

Fig. 223: Adjusting the seat heater and seat climate control

3 Switch Seat heater and seat climate control

The active seat climate control ensures a dry seat surface.

Any body moisture in the contact area with the seat is removed. This provides a comfortable cool and dry seat.

- ▶ To turn the seat heater and the seat climate control on actuate the switch 2.
 - ▷ Position 0: Seat heater and seat climate control turned off
 - ▷ Position 1: Seat heater switched on
 - ▷ Position 2: Seat climate control switched on
- ▶ Use the switch -a- to set the seat heater and seat climate control to the desired output stage.

²⁸⁾ Option

410814

410818

LWT193517568/02/01_01_2021/en

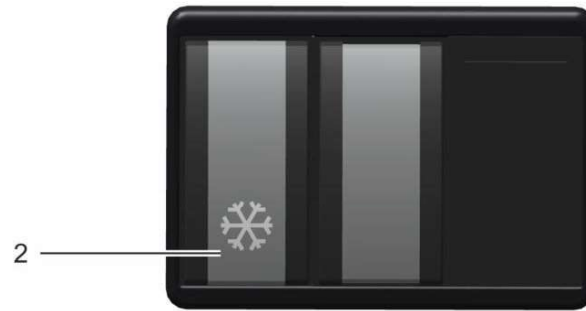

414812

Fig. 242: Air conditioner master switch

2 Air conditioner master switch

- ▶ Push air conditioner master switch **2** down.
 - ▷ Heating and air conditioning are turned on.

Adjusting the temperature



414813

Fig. 243: Temperature switch

1 Temperature switch

- ▶ Turn the temperature switch **1** clockwise.
 - ▷ The outflow temperature is increased.
- ▶ Turn the temperature switch **1** anti-clockwise.
 - ▷ The outflow temperature is reduced.

Acoustic reversing warning device

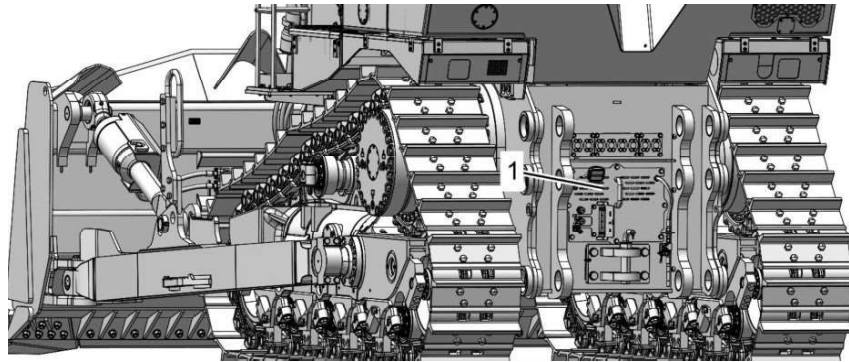

414815

Fig. 265: Reversing alarm

1 Reversing alarm

The reversing alarm sounds automatically when the machine is reversing. The sound level is set automatically.

Checking the acoustic reversing warning device

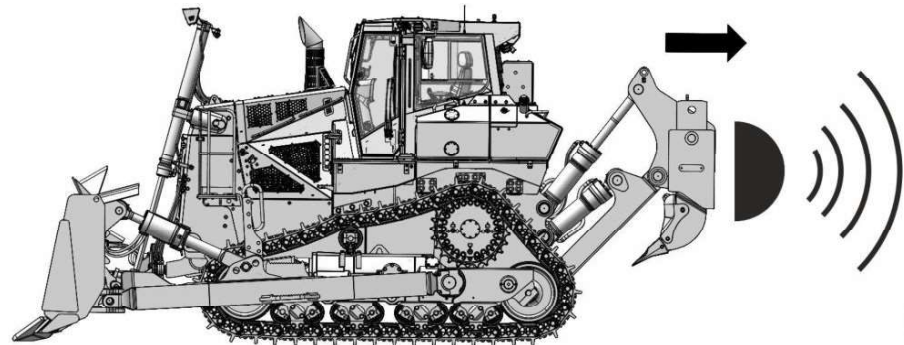

414816

Fig. 266: Checking the acoustic reversing warning device



WARNING

Restricted visibility!
Danger to life.

- ▶ Make sure there is nobody in the danger area around the machine.
- ▶ Start the machine.
- ▶ Put parking switch in operating position.
- ▶ Move the travel joystick backward.
 - ▷ Acoustic warning signal sounds.

CLICK HERE TO **DOWNLOAD** THE COMPLETE MANUAL

- Thank you very much for reading the preview of the manual.
- You can download the complete manual from: www.heydownloads.com by clicking the link below



- Please note: If there is no response to CLICKING the link, please download this PDF first and then click on it.

CLICK HERE TO **DOWNLOAD** THE COMPLETE MANUAL

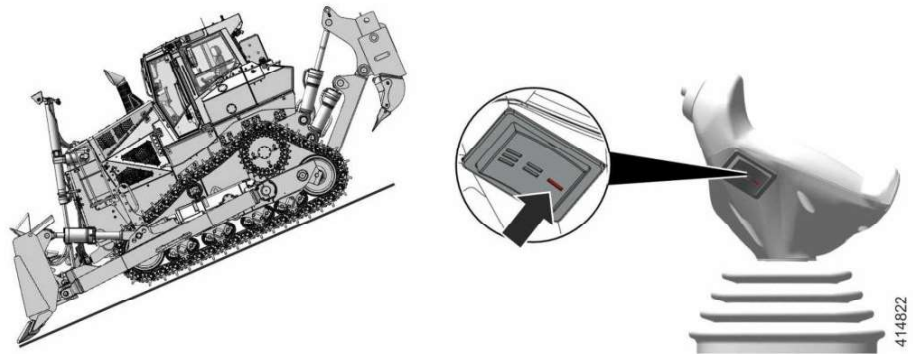

Fig. 302: Downhill travel

**WARNING**

Uncontrolled travel behaviour!
Danger to life.

- ▶ Move the switch on the travel joystick to I before driving on slopes.
- ▶ Travel at not more than 2 mph.
- ▶ Set engine speed controller to full load.

Travel mode with engaged travel joystick

Adjusting travel speed

The travel speed can be reduced or increased in 0 mph increments both before and while driving by using a button on the engaged travel joystick. The travel speed can be set separately for forward and reverse travel. After turning the diesel engine off, the travel speed is reset to the standard setting of 2 mph.

Name	Value
Adjustable travel speed	2 to 7 mph

Tab. 33: Adjustable travel speed

**Note**

To make optimum use of machine power:
▶ Carry out heavy pulling work at max. 2 mph.

3.3.7 Using the emergency stop button to stop and continue the operation

Using the emergency stop button to stop the operation

In dangerous or unclear situations, the machine can be stopped immediately by pressing the emergency stop button.



WARNING

Always wear a safety belt!
Injury.

- ▶ Always wear safety belt before putting machine into service.

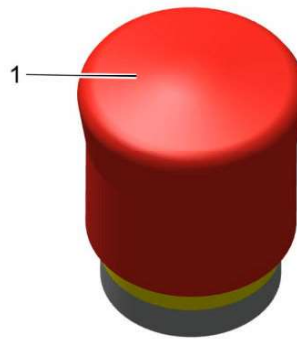

414728

Fig. 321: Emergency stop button

1 Emergency stop button

- ▶ Press the emergency stop button 1.
 - ▷ The machine comes to an abrupt stop.
 - ▷ The diesel engine is turned off.
 - ▷ Working attachment can still be moved.

Continuing the operation

- ▶ Set travel joystick to neutral position.
- ▶ To unlock emergency stop button 1: pull out emergency stop button 1 to the stop.
- ▶ Start diesel engine.

3.3.8 Using external emergency stop button to stop and continue the operation (option)

Using external emergency stop button to stop the operation

In dangerous or unclear situations, the machine can be stopped immediately by pressing the external emergency stop button.

Quick tilt of the dozer blade

Quick tilt of the dozer blade to the left



Fig. 339: Quick tilt of the dozer blade to the left

- Move the blade control lever to the left to the stop via the pressure point.

Quick tilt of the dozer blade to the right

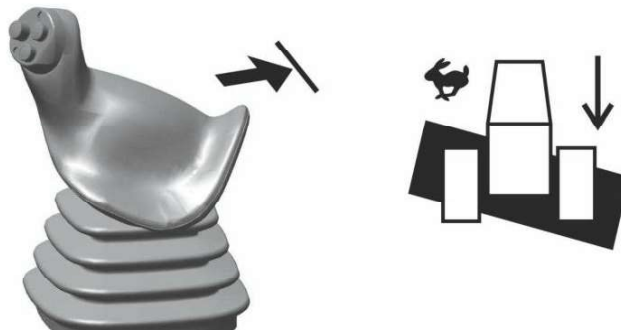

Fig. 340: Quick tilt of the dozer blade to the right

- Move the blade control lever to the right to the stop via the pressure point.

Mechanical cutting angle adjustment

The cutting angle of the dozer blade can be adapted to the current ground conditions by changing the strut as well as the tilt cylinder position in three stages.



414836

Fig. 361: Steep tooth angle

2 Steep tooth angle button

- ▶ Press the *Steep tooth angle* button **2** until the marking for pinning is visible.
 - ▷ The tooth is shortened.
- ▶ If necessary, move the machine slightly forward or backward so that the tooth does not twist in the guide.
- ▶ Knock in the pin on the ripper tooth and secure with ring and hex head screw.

Adjusting the tooth length hydraulically

The length of the ripper tooth on the single tooth ripper can be adjusted in 3 positions to match it to the respective conditions.



WARNING

Danger of accident if the ripper tooth falls out!

- ▶ Adjust the tooth length only on solid ground.
- ▶ It is prohibited to remain in the hazard zone.



414836

Fig. 362: Steep tooth angle

2 Steep tooth angle button

- ▶ Press the *Steep tooth angle* button **2** until the tooth angle adjustment cylinders are fully extended.
- ▶ Lower the ripper tooth to the ground.

- ▶ If necessary, rip the ground crosswise.
- ▶ On slopes, always rip while driving downhill.

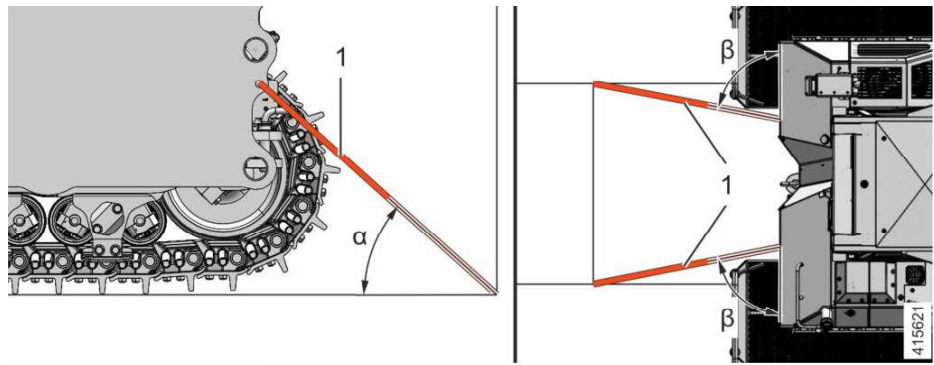

Fig. 421: Rear anti-tipping angle

1 Rigging chain

Name	Value
Vertical anti-tipping angle α	$60^\circ < \alpha < 90^\circ$
Horizontal anti-tipping angle β	$0^\circ < \beta < 90^\circ$

Tab. 40: Anti-tipping angle

- ▶ Fasten rigging chain **1** to marked anti-tipping points while adhering to the anti-tipping angle (see: tab. 40, page 231) .
- ▶ Pretension rigging chain **1** with max. 220 lb_r.
- ▶ Rig machine with min. 4,050 lb_r per chain.

Unloading the machine



DANGER

Person giving signals in danger area!
Danger to life.

- ▶ Make sure there are no unauthorised persons in danger area.
- ▶ Always maintain visual contact with person giving signals.

- ▶ Remove rigging chains and chocks.
- ▶ Access machine using a suitable access aid.
- ▶ Drive machine off of loading surface.
- ▶ Take the machine out of service.

3.6.2 Loading the machine with a crane

Observe the safety instructions for loading the machine with a crane. (For more information see: 2.6.13 Safety guidelines for loading machine with a crane, page 64)

Pay attention to the weight and dimensions of the machine. (For more information see: 1.2 Technical data, page 17)

Ensure that following requirements are met:

- The machine is cleaned.
- The machine is out of service.

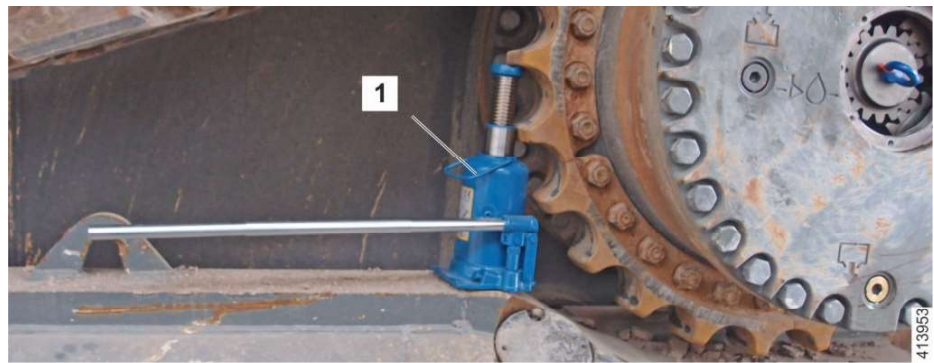

Fig. 438: Positioning the hydraulic lift

- ▶ Position the hydraulic lift **1** on the sprocket segment.



Fig. 439: Pushing in the sun gear

- ▶ Slide the sun gear carefully into the gear teeth in the gear.

Troubleshooting

The sun gear cannot be pushed in?

- ▶ Lift the sun gear slightly so that it can be pushed in.
 - ▶ Actuate the hydraulic lift on the sprocket segment until the sun gear can be pushed in.
-
- ▶ Remove the eyebolt from the sun gear.
 - ▶ Install a new seal on the gear cover.

Malfunction / error	Cause	Remedy
Exhaust gases are blue.	Oil level too high in diesel engine	▶ Correct the oil level.
	Engine oil gets burnt in the combustion chambers.	▶ Contact Liebherr customer service.
	Compression-side seal on exhaust turbo charger defective	▶ Contact Liebherr customer service.
	Exhaust gas-side seal on exhaust turbo charger defective	▶ Contact Liebherr customer service.
	Crankcase housing vent defective	▶ Check the crankcase housing vent. ▶ Change the crankcase housing vent if necessary.
	Piston rings defective	▶ Contact Liebherr customer service.
	Valve stem seals defective	▶ Contact Liebherr customer service.
Exhaust gases are white.	Injection delayed	▶ Contact Liebherr customer service.
	Heater flange (temperature < 14 °F)	▶ Check the heater flange. ▶ Change the heater flange if necessary.
	Coolant in combustion chamber	▶ Contact Liebherr customer service.
Diesel engine rattles.	Combustion problems	▶ Contact Liebherr customer service.
Diesel engine knocks.	Valve clearance too large	▶ Adjust the valve clearance.
	Injector damaged or carbonised	▶ Contact Liebherr customer service.
	Bearing damage	▶ Contact Liebherr customer service.
	Piston rings worn; piston rings broken; piston seized	▶ Contact Liebherr customer service.
Abnormal noises	Leaks on the intake lines and exhaust pipes cause whistling sounds.	▶ Rectify the leaks. ▶ Change the seal if necessary.
	Foreign bodies in the compressor or turbine	▶ Contact Liebherr customer service.
	Scraping of turbine gear or compressor gear on housing	▶ Contact Liebherr customer service.
	Seized bearings of the rotating parts	▶ Contact Liebherr customer service.

LWT93517568/02/01_01_2021/en

Fuse	Value	Unit	Name / Function
F157	5	A	Fuse for wireless preparation ^{A)}

Tab. 45

A) Option

- ▶ Check corresponding fuse.
- ▶ Replace fuse if necessary.

Fuse for the radio (option)

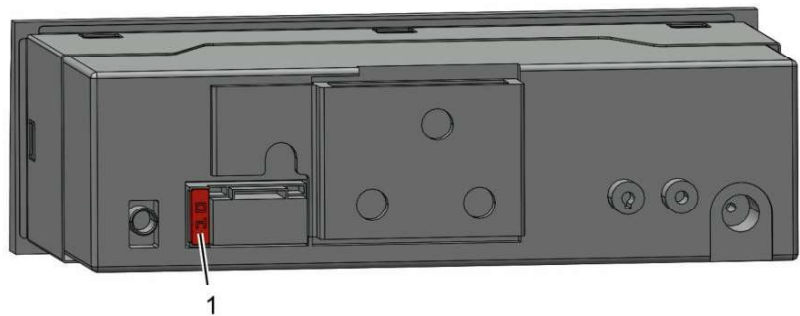

414529

Fig. 448: Fuse for the radio

1 Fuse

If the radio is not functioning:

- ▶ Remove the radio.

Fuse	Value	Unit	Name / Function
F400	10	A	Radio fuse

Tab. 46







- ▶ Check fuse 1 and replace if necessary.
- ▶ Replace fuse 1 if necessary.

Checking the fuses

On the main circuit board in the central electronic compartment, there is one test base to check for any potential defective fuses.

5.2 Fill quantities and lubrication chart

5.2.1 Recommended lubricants

Name	Recommended lubricant	Symbol	Quantity
Diesel engine (with filter change)	Liebherr Motoroil 5W-30 Liebherr Motoroil 5W-30 low ash ^{A)}		17.17 gal
	Liebherr Motoroil 10W-40 Liebherr Motoroil 10W-40 low ash ^{A)}		
Hydraulic system	Liebherr Hydraulic Basic 68		
	Liebherr Hydraulic Basic 100 Liebherr Hydraulic HVI Liebherr Hydraulic Plus Liebherr Hydraulic Plus Arctic		
System content			134.73 gal
Tank contents			71.33 gal
Splitter box	Liebherr Hypoid 85W-140 EP		2.25 gal
	Liebherr Syntogear Plus 75W-90 Liebherr Gear Basic 90 LS		
Travel gearbox (both left and right)	Liebherr Hypoid 85W-140 EP		9.51 gal
	Liebherr Syntogear Plus 75W-90		
Travel gearbox duo cone (slip ring) seal	see hydraulic system		4.23 gal
Undercarriage carrier (both left and right)	Liebherr Hypoid 85W-140 EP		9.51 gal
Axle bearing (both left and right)	see hydraulic system		2.3 gal
Bearings and track tensioner	Liebherr Universal grease 9900		11.02 lb
	Liebherr Universal grease Arctic		

Tab. 48: Recommended lubricants

A) For machines with stage V diesel engines.

		Dust intensive use	Normal use
Bio use (oil analysis required)	Liebherr PAO biodegradable	At the time of transfer, then every 250 h thereafter, at least once a year	At the time of transfer, then every 1000 h thereafter, at least once a year
	Liebherr Hydraulic Plus		
	Liebherr Hydraulic Plus Arctic		

Tab. 69: Oil analysis

Filter change

	Dust intensive use	Normal use
Liebherr return filter	Every 250 h	Once after 500 h, then every 1000 h thereafter
Liebherr breather filter	Every 500 h	Every 2000 h

Tab. 70: Filter change

Oil change

	Without oil analysis	With oil analysis ⁴⁰⁾
Liebherr Mineral oil	Every 3000 h	Every 6000 h
Liebherr Hydraulic Basic 68		
Liebherr Hydraulic Basic 100		
Liebherr Hydraulic HVI		
Liebherr PAO biodegradable	Every 4000 h ⁴¹⁾	Every 10000 h
Liebherr Hydraulic Plus		
Liebherr Hydraulic Plus Arctic		

Tab. 71: Oil change

5.3.7 Lube oils for splitterboxes



Quality

Recommended lubricant	Specification
Liebherr Hypoid 85W-140 EP	API: GL5
	MIL-L: 2105 D, PRF-2105 E

⁴⁰⁾ Change the oil after a negative oil analysis.

⁴¹⁾ An oil analysis is prescribed for bio use.

5.6.3 Carrying out the maintenance and inspection for the optional equipment in the scope of delivery according to the manufacturer's operator's manual or manufacturer's data

- ▶ Determine the maintenance and inspection requirements for the optional equipment in the scope of delivery.
- ▶ Carry out the maintenance and inspection for the optional equipment in the scope of delivery according to the manufacturer's operator's manual or manufacturer's data.

- ▶ Check the water separator **3** of the fuel pre-filter.

If there is water in the water separator **3** of the fuel pre-filter:

- ▶ Place a receptacle under the drain hose **4**.
- ▶ Loosen the bleeder screw **2** by two turns in an anti-clockwise direction.
- ▶ To open drain valve **1**: turn drain valve **1** anti-clockwise.
 - ▷ Water drains.

When the water has drained:

- ▶ To close drain valve **1**: turn drain valve **1** clockwise.
- ▶ Tighten the bleeder screw **2** with 4 ft-lb.

5.9.3 Fuel tank: draining condensation and sediment

Ensure that following requirements are met:

- Machine is in maintenance position.
- A suitable receptacle is available.

The shut-off valve for the fuel system is accessible via the right engine compartment door.

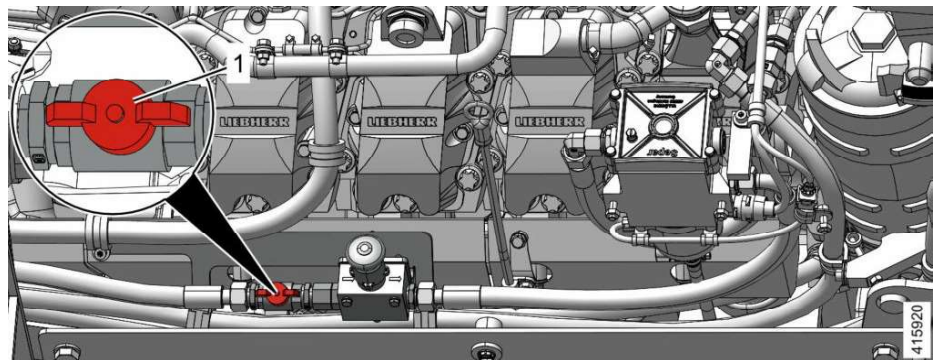

Fig. 510: Fuel system shut-off valve

- 1** Shut-off valve

- ▶ Close the shut-off valve **1** for the fuel system.

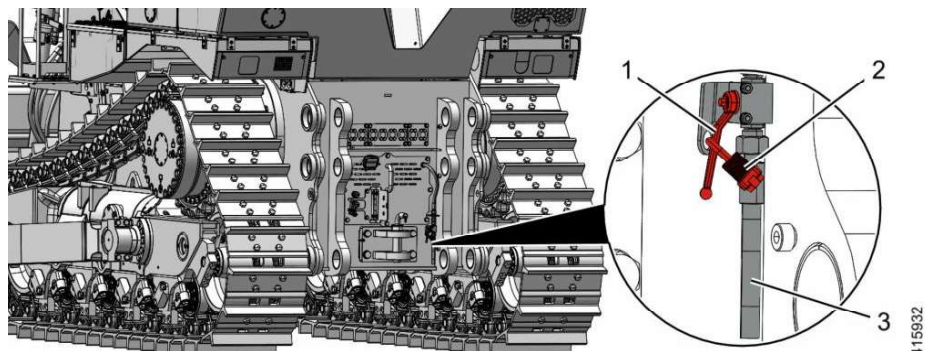

Fig. 511: Fuel tank drain valve

- 1** Shut-off valve
- 2** Lock

- 3** Drain hose

- ▶ Place a suitable receptacle under the drain hose **3**.

5.12 Hydraulic system

5.12.1 Checking oil level in the hydraulic tank and topping up oil

Checking the oil level in the hydraulic tank

Ensure that following requirements are met:

- Machine is in maintenance position.
- The hydraulic oil is cold.

The sight gauge of the hydraulic tank is located on the left of the refuelling pump container.

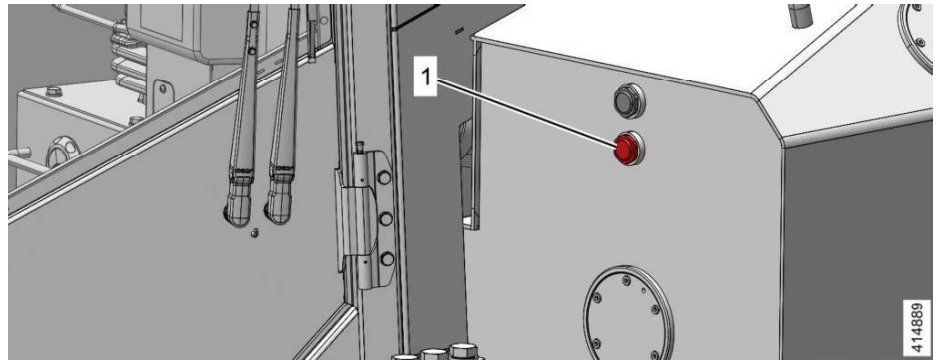

Fig. 525: Sight gauge

1 Sight gauge

- ▶ Check oil level.

If oil level is below centre of sight gauge 1:

- ▶ Top up hydraulic oil.

Topping up hydraulic oil

Ensure that following requirements are met:

- Machine is in maintenance position.
- The hydraulic oil is cold.
- Hydraulic oil as per the specification is available. (For more information see: [5.3.6 Hydraulic oils, page 280](#))

5.17.2 Checking the track tension and adjusting, if necessary

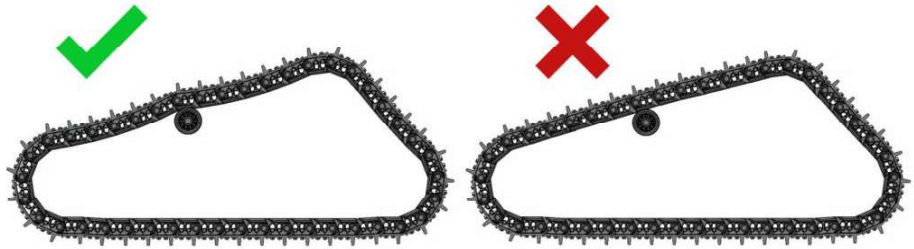

416110

Fig. 536: Track tension

Check the track tension regularly and retension the track, if necessary, otherwise the undercarriage wear increases. An excessively tensioned track increases dirt build up and wear. An insufficiently tensioned track can jump over and, as a result, damage the drive train.

Checking the track tension

Make sure the following preconditions are met:

- Machine is in maintenance position.
- A ruler is to hand.
- ▶ To relieve pressure on the track: drive the machine forward and backward.
- ▶ Place a ruler in the area between the idler and the travel drive.

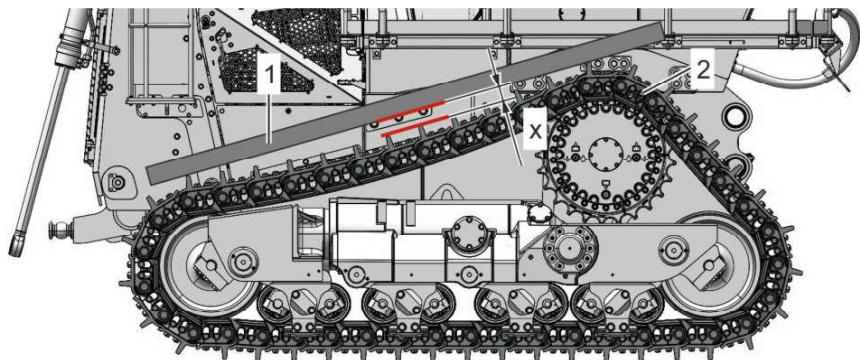

416113

Fig. 537: Checking the track tension

- | | | | | |
|---|-------|--|---|-----|
| 1 | Ruler | | x | Sag |
| 2 | Track | | | |

- ▶ Measure the sag **x** between the lower edge of the ruler **1** and the track grouser.

Under operating conditions the sag **x** between the idler and travel drive must be $5.12'' \pm 0.39''$ in.

If the sag **x** is larger or smaller:

- ▶ Adjust the track tension in the manner described below and by taking the operating conditions into account.

5.19 Cleaning the machine

5.19.1 Wet cleaning machine

Cleaning machine

NOTICE

Incorrect cleaning!
Damage to painted surfaces.

- ▶ Only carry out high-pressure cleaning at more than 200.15 psi if 30 days have passed since delivery or repainting.
 - ▶ In the first 30 days following delivery or repainting, only clean with low pressure.
-

NOTICE

Incorrect cleaning!
Damage to electrical components.

- ▶ Only clean electrical components with low pressure.
-

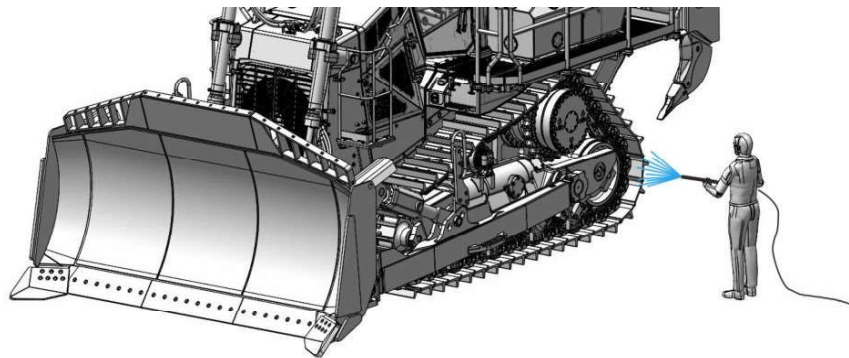

416163

Fig. 550: Wet cleaning

- ▶ Wet clean the machine.
- ▶ Lubricate all lubricating points on the machine.

Cleaning diesel engine

NOTICE

Incorrect cleaning!
Damage to electrical components.

- ▶ Only clean electrical components with low pressure.
-
- ▶ Clean the diesel engine carefully.
 - ▶ To dry diesel engine: bring diesel engine to operating temperature.

CLICK HERE TO **DOWNLOAD** THE COMPLETE MANUAL

- Thank you very much for reading the preview of the manual.
- You can download the complete manual from: www.heydownloads.com by clicking the link below



- Please note: If there is no response to CLICKING the link, please download this PDF first and then click on it.

CLICK HERE TO **DOWNLOAD** THE COMPLETE MANUAL