



# Technical Manual

CLICK HERE TO **DOWNLOAD** THE COMPLETE MANUAL

- Thank you very much for reading the preview of the manual.
- You can download the complete manual from: [www.heydownloads.com](http://www.heydownloads.com) by clicking the link below



- Please note: If there is no response to CLICKING the link, please download this PDF first and then click on it.

CLICK HERE TO **DOWNLOAD** THE COMPLETE MANUAL

## SUGGESTIONS FOR INSPECTING

### **PREVENTIVE MAINTENANCE MEANS PEAK PRODUCTION AND LONGEVITY.**

Open pit mining equipment undergoes tremendous shock and stress. Marion's design considers these loads. This machine, built with an ample reserve of power and strength, will meet the demands of its task. Marion's engineers cannot foresee the conditions imposed by abuse, neglect and mismanagement. These factors damage any piece of equipment more than years of continuous operation and normal wear. Care, sound judgement and reason govern the economic need in the operation of power equipment.

Downtime exists, but an ongoing program of inspection and evaluation minimizes it. Awareness of unusual conditions generally warns personnel before breakdown occurs. Normal wear of machinery parts escapes exact definition. Parts do not suddenly expire. Wear takes place at varying degrees over time. Constant checking indicates a wear pattern. An alert maintenance crew checks ALL structural members for evidence of stressed, broken or loose parts.

Minor cracks occur in steel structures. It's true of ALL machines. This is NOT SERIOUS when weld repaired while SMALL. Cold weather causes faster expansion and brittleness than warm weather. Early detection and quick repair prevents failure. A stretch, bend or defect often shows up in condition of surface paint. A collection of dust along a line may indicate a crack in the metal. Look closely at areas around openings where angles are cut out. Also check gusset connections and points where thin and heavy metals join. The good crew watches for loose bolts, nuts, cap screws, lock washers and other locking devices. Rod bolts are important too. Signs of scuffed paint, worn or bright spots next to any part indicates movement and becomes second nature to most personnel. Retighten ALL bolts shortly after initial start-up.

Replacement and maintenance schedules may conform to planned shutdowns. Lack of proper lube, poor adjustments and abuse cause and speed up wear. These facts show up as the MAIN reasons for breakdown. If any part shows wear or distortion beyond expected normal wear, order replacement and quickly install. The cost of parts is minimal when compared to breakdown cost and loss of man hours and production.

Production machines operating 24 hours, 7 days every week deserve an 8 hour inspection and cleaning every 10 days. Cleaning before inspection eliminates dirt and dust falling into machinery parts when inspection plates and covers are removed.

On the upper frame, a solvent makes removal of the accumulation of grease around bearings, gears, motors and the like easier.

**EXCITATION – START AND STOP PUSHBUTTONS.** These buttons energize (Start) or de-energize (Stop) the operating control circuits (primary controls). This enables the operator to temporarily disconnect the controls without shutting down the machine. The “Start” button is illuminated green when the button is depressed and remains lit until the “Stop” button is actuated. The “Stop” button should be depressed before the operator leaves his seat for any reason.

**CONTROL PANEL –** Located on the slopping part of the left hand console, contains four switches, three pushbuttons, thirteen red warning lights and the steering lever.

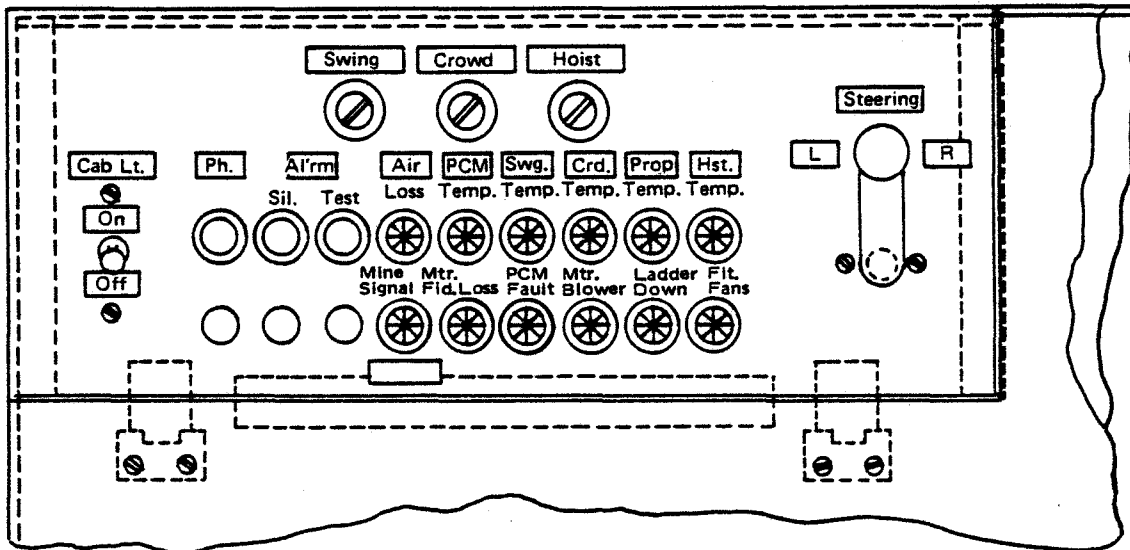

**SWING BRAKE –** Two position switch, SET or REL (Release) the swing brake on each rotating gear case motor.

**CROWD BRAKE –** Two position switch, SET or REL (Release) the crowd brake on each crowd motor located on the boom.

**HOIST BRAKE –** Two position switch, SET or REL (Release) the hoist brake located on the hoist motor.

**NOTE:** The brakes are holding brakes ONLY and are not intended to stop or retard the rotating of the motor armature and/or machine motion, except in emergency.

**CAB LIGHT –** This toggle switch turns ON or OFF the lights in the operator’s cab.

**PHONE –** When the pushbutton is depressed, a signal bell will ring in the electrical compartment at rear of machine.

**SLOWLY** start the swing and gently accelerate to avoid excessive side thrust on boom and handle. Approaching dumping point reverse the swing controls to bring the dipper smoothly over the desired spot and and stop. When the swing stops at the dump point, return lever to neutral position.

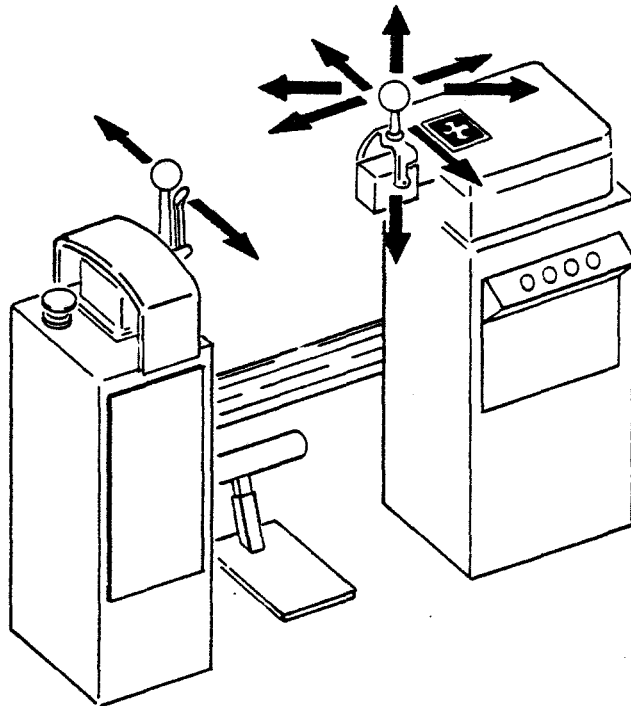

Trip the dipper door by pressing the thumb latch on the crowd lever. Only hold the latch in long enough for the latch bar to extract from the dipper latch plate.

After the material has dumped, **SLOWLY** move the swing control to the desired direction of rotation. While returning to the pick up area lower the dipper to shut the dipper door.

On reaching the pick up area, be sure to stop the swing motion before the dipper enters the bank. Use both control levers as required to repeat the digging cycle.

**PROPELLING THE MACHINE** — Before operating the propel mechanism ensure that:

- A. The dipper should be under boom point, with the handle in a horizontal position to improve machine stability.
- B. The hoist and crowd brakes selector switches must be in "Set" position.

CODE OR SYMBOL NO.		ASTM or TEST	MO	OILS PO
Viscosity @ 210°F. SUS	- Summer	D-446	60-68	43
	Winter		51-55	43
Viscosity Index, Min.		D-567	90	101
Rust Test - 48 hrs., Syn. Sea Water		D-665	None	—
SAE Viscosity No.	- Summer	—	30	10
	Winter		20W	10
Aniline Point Min.		D-611	—	215

**GL—GEAR LUBRICANTS (OIL TYPE)**

CODE OR SYMBOL NO.	ASTM or TEST	GL-90	GL-140	GL-200	GL-250
Pour Point °F. Max.	D-97	0	10	20	30
Flash Point °F. Min.	D-92	410	410	410	410
Viscosity @ 100°F. SUS (Min.)	D-446	1100	2000	3500	4500
Viscosity @ 210°F. SUS	D-446	80-120	120-180	180-210	210-260
Viscosity Index (Min.)	D-567	80	80	80	80
Equiv. AGMA Lubricant No.	—	6 EP	7-8 EP	8 EP	8a
SAE Viscosity No.	—	90	140	140/250	250
EP Timken, Min. OK	—	65	65	65	65
Copper Corrosion Max.	D-130	2	2	2	2

Gear Lubricant	Oil Temperature °F.	
	Min.	Max.
GL-90	0	105
GL-140	10	125
GL-200	20	140
GL-250	30	150

**NOTES.**

---

<b>Section 4 – Mechanical Adjustments (cont.)</b>	<b>Page</b>
Operation and Adjustment of Cams (Table 1) .....	4-50
Vernier Adjustment .....	4-51
Maintenance .....	4-51
Hoist Machinery Module .....	4-54
Hoist Drum .....	4-54
To Remove Drum and Drum Gear .....	4-54
To Remove Hoist Drum Bearings .....	4-60
Inspection of Drum .....	4-60
To Install Hoist Drum Bearings .....	4-60
Installation of Drum Gear and Drum .....	4-61
Bolting Procedure for Hoist Gear .....	4-61
Hoist Intermediate Gear .....	4-63
Hoist Intermediate Shaft Assembly .....	4-63
To Remove and Disassemble Intermediate Shaft Assembly .....	4-64
To Reassemble and Reinstall Intermediate Shaft Assembly .....	4-64
Hoist Motor Pinion Shaft .....	4-68
To Remove Motor Pinion Shaft .....	4-68
To Install Motor Pinion Shaft .....	4-68
Hoist Brake .....	4-70
Auxiliary Winch .....	4-71
Hoist Ropes .....	4-71

by the judgement of the inspector. Where corrosion is present, all the known methods for estimating the remaining strength of a wire rope become useless. It is, therefore, absolutely essential that corrosion be controlled, which can be done by proper and sufficient lubrication so that additional safe rope service may be obtained.

It is not possible to estimate definitely the remaining strength for all conditions of service. From the examination of worn ropes from a particular installation, together with actual tests for remaining strength of the worst worn rope lay, data can be accumulated which will eventually allow reasonably close estimates to be made.

The number of broken wires which develop in a wire rope is the usual reason for removal. This can be considered the "safety value" that should be evident by visual inspection. The rope lay containing the greatest number of broken wires is usually the weakest section of the rope and is comparable to the "weak link" in a chain, except that the condition is visible.

Experience has indicated that the condition of the worst rope lay is a safe guide for rope removal. A rope lay is that length of rope in which one strand makes one complete revolution about the core. The examinations of this worst lay for abrasion and broken wires should give sufficient information to permit a close estimate of the remaining strength. The estimate can be checked by an ultimate strength test.

Refer to Section 7 of this manual for additional information on the care of wire rope.

#### **TO REPLACE BOOM SUPPORT ROPES.**

1. Jack the boom by crowding the dipper into the ground to slacken support ropes and set the crowd brakes.

**NOTE:** All four ropes should be replaced; but, no more than one at a time should be disconnected during replacement.

2. Attach crane whip line to support rope at either end. Remove hardware and pin and lower rope to ground. Repeat procedure at other end of rope.
3. Pick up one end of new rope with whip line, lift it into place and pin. Pick up and pin opposite end of rope. Repeat procedure for each rope to be replaced. Equalizers will adjust for any difference in rope lengths.

## CROWD SYSTEM —

**CROWD MACHINERY** is located on the boom. It's function is to mechanically move the dipper away from the boom (crowd motion) or toward the boom (retract motion) during the dig cycle. Two pinions, splined to the shipper shafts, mesh with the dipper handle racking on the underside of the handle. As the pinions rotate the dipper handle moves in and out guided by the yoke block.

The **YOKE BLOCK** is pinned to two bearing housings mounted on boom trunnions. Wear pads, inside the yoke block, provide replaceable wearing surfaces and keep the dipper handle racks in mesh with the shipper shaft pinions. There are two wear pads at the top of the yoke block, two wear pads on each side of the forward end, and one wear pad on each side at the rear end.

Two electric motors drive the crowd machinery thru double reduction gearing. Each motor drives an intermediate gear shaft and pinion assembly which in turn, drives the shipper shaft gear and shipper shaft.

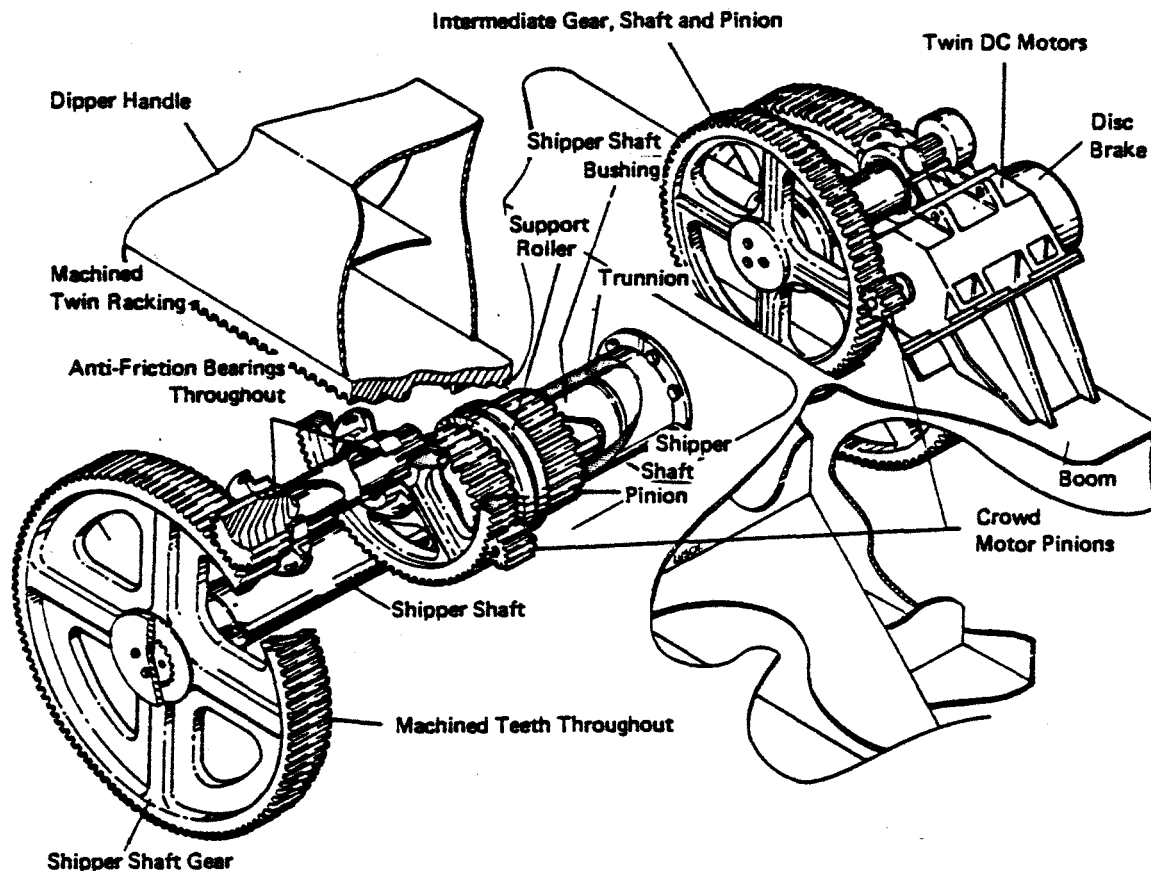

**CROWD MACHINERY**

**TO REMOVE SHIPPER SHAFT AND/OR ROLLER AND CROWD PINION (Refer to figures titled " REMOVAL OF SHIPPER SHAFT, STEPS 1 and 2"):**

**NOTE:** Procedure applies to either left-hand or right-hand shipper shaft.

1. Move dipper handle to vertical position, with dipper resting on ground, to relieve handle weight. Place a wedge or spacer between bottom of handle and yoke block to hold handle away from crowd pinion.
2. Disconnect electrical power from machine.
3. Remove shipper shaft gear guard.
4. Remove gear retainer plate and temporarily remove shipper shaft gear.
5. Remove bearing retainer plate.
6. Re-install gear on shipper shaft splines, except position gear hub 4-1/2 inches from bearing housing and insert two pull rods into end of shipper shaft.
7. Tack weld two temporary spacers to gear hub and re-install gear retainer over pull rods.
8. Install nuts on pull rods and tighten them until shaft moves far enough to free bearing.



**CAUTION:** Support shaft gear, roller and pinion as shaft is withdrawn. Roller will be free at this point; continued shaft movement will release pinion.

9. Remove shaft completely by straight pull on shaft gear.

**TO INSTALL SHIPPER SHAFT, ROLLER AND PINION:**

1. Install shaft bearing. See Section 7 for information on bearing installation. Pre-lube bearing, shaft splines and bushing, and roller bushing. Insert shaft through boom housing, pinion and roller.
2. Install bearing retainer, shaft gear, gear retainer and gear guard.

**NOTE:** Prior to assembly, remove two temporary spacers from gear by burning off and grinding.

If dimension is LESS than 4.562 inches (11.587 cm) adjustment is done as given below. If dimension is greater, reinstall shield, as adjustment is not necessary at this time.

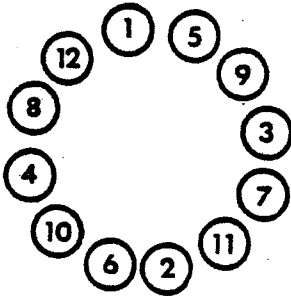

1. Remove locknuts in alternating sequence, as shown in sketch, in increments of 1/4 of the exposed stud thread length. If a stud comes loose from the mounting flange, clean stud threads thoroughly. Apply Loctite 277, or equivalent. Stud must be threaded back into the mounting flange hole until it bottoms.

2. With locknuts removed, the end plate, spring housing and pressure plate can be removed as an assembly.
3. Remove the wear spacers from the studs.
4. Reassemble the end plate, spring housing and pressure plate as an assembly on the studs with the wear spacers now located on the outside of the spring housing.

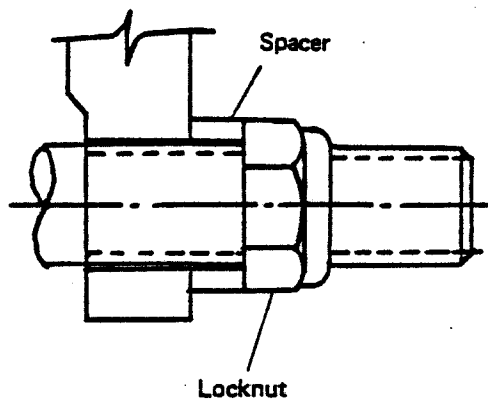

5. Lubricate stud threads with 30 weight oil or "Never Seez". Assemble locknuts on studs and torque to 200 foot-pound (271 Nm) using the same sequence as they were removed.



**CAUTION:** After adjustment, a minimum of 0.040 inch (0.1016 cm) running clearance must exist between each friction disc and each disc.

6. Reinstall shield.

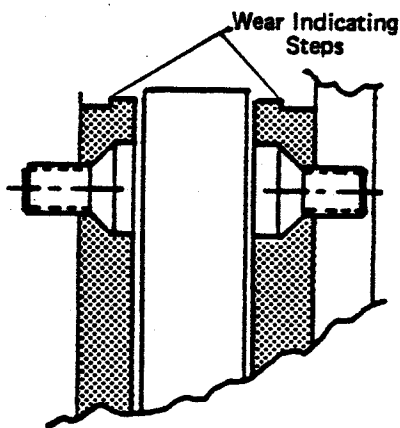

**FRICION DISC** – To determine if friction discs need to be replaced, release air (engage brake), remove shield, and check if the wear indicating step on the friction discs is still visible. Also, check if oil or grease has contaminated the surfaces. If the step is visible and the surfaces are NOT oil or grease contaminated, replace the shield as no replacement is necessary. If the step is not visible, or if surfaces are oil or grease contaminated, the friction disc must be replaced.

**CROWD LIMIT – TWO STAGE CROWD LIMIT** consists of two independent sets of limits: an initial limit and a final limit. The purpose of the initial limit is to terminate reference in both the crowd and retract directions. Should the initial limit be over-traveled, the final limit is actuated, which sets the crowd motor brakes. The working ranges between the limits are depicted below.

In the crowd direction, when the shipper shaft pinion reaches position "C" on the rack, the initial crowd limit (cam No. 1) should be set to terminate reference. Cam No. 3 should be set to trip at position "D" on the rack, applying the crowd brakes. Similarly, for the retract direction, cam No. 2 should be set to terminate reference at position "A" and the final crowd limit, cam No. 4, should apply the crowd brakes at position "B".

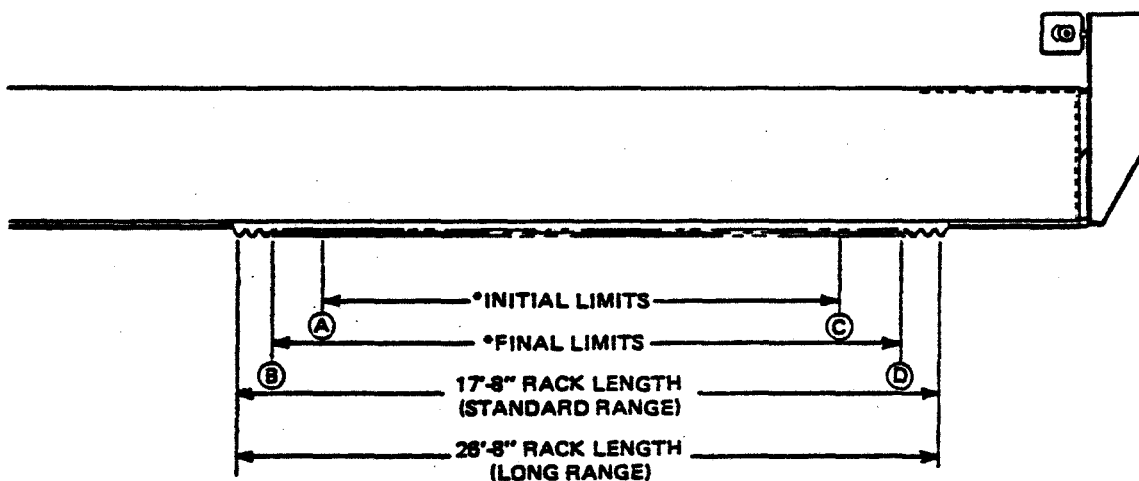

**NOTE:** \*Actual working ranges are to be determined in the field for each particular application.

**CROWD LIMIT SWITCH** (General Electric IC 9446-C220DA) is a rotating-cam type designed for continuous rotation in either the clockwise or counterclockwise direction. Contacts are provided for controlling four circuits.

Each set of contacts is actuated by means of cams which are supported on a separate disk welded to the main shaft. As the shaft rotates, these cams cause the contacts to open and close. The sequence of operation of the contacts depends on the position of the various cams with respect to the shaft.

The torque requirements of the switch are a maximum of 12 inch-pounds to open one contact. The contacts are forced open by direct cam action and are spring closed. This provides a fail-safe condition because opening of the circuit is not dependent on springs or other parts that could fail. This switch is furnished with snap-action contact blocks.

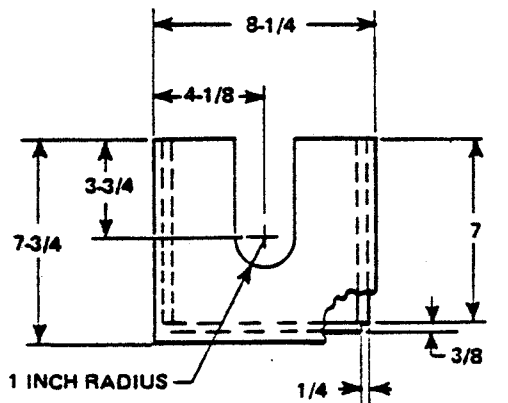

NOTE: SAME BASE USED FOR PULLING YOKE  
BLOCK BEARING HOUSING PINS – SEE CROWD  
SYSTEM SECTION OF THIS MANUAL

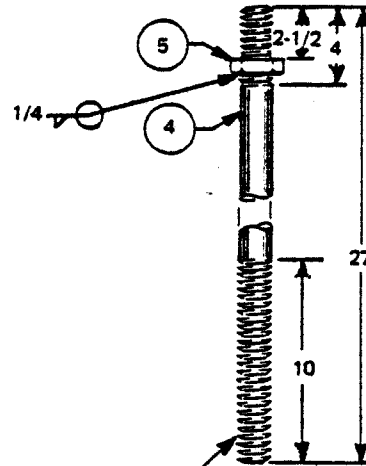
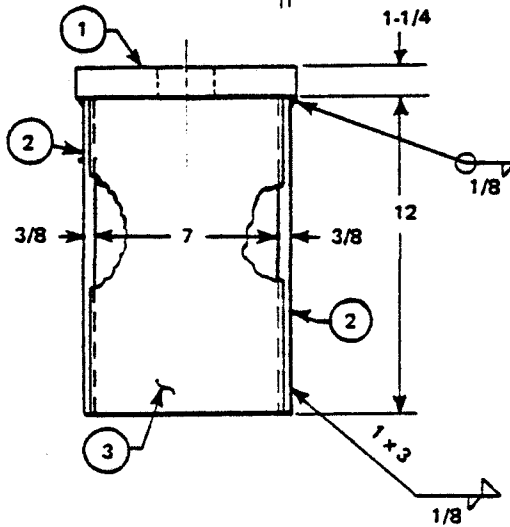

1-1/2 – 6 UNC THREADS BOTH ENDS

PORTABLE BASE FOR JACK				
QTY	ITEM	NAME	SIZE	MAT'L
1	1	BASE PLATE	1-1/4 x 7-3/4 x 8-1/4	STEEL
2	2	SIDE PLATE	3/8 x 7 x 12	STEEL
1	3	END PLATE	3/8 x 7-1/4 x 12	STEEL
1	4	PULL ROD	1-1/2 x 27	
1	5	JAM NUT	1-1/2 – 6UNC	PUR.
1	6	FULL NUT	1-1/2 – 6UNC	PUR.

MANUFACTURING DETAILS – PORTABLE BASE AND PULL ROD  
USED TO PULL HOIST DRUM SHAFT PINS

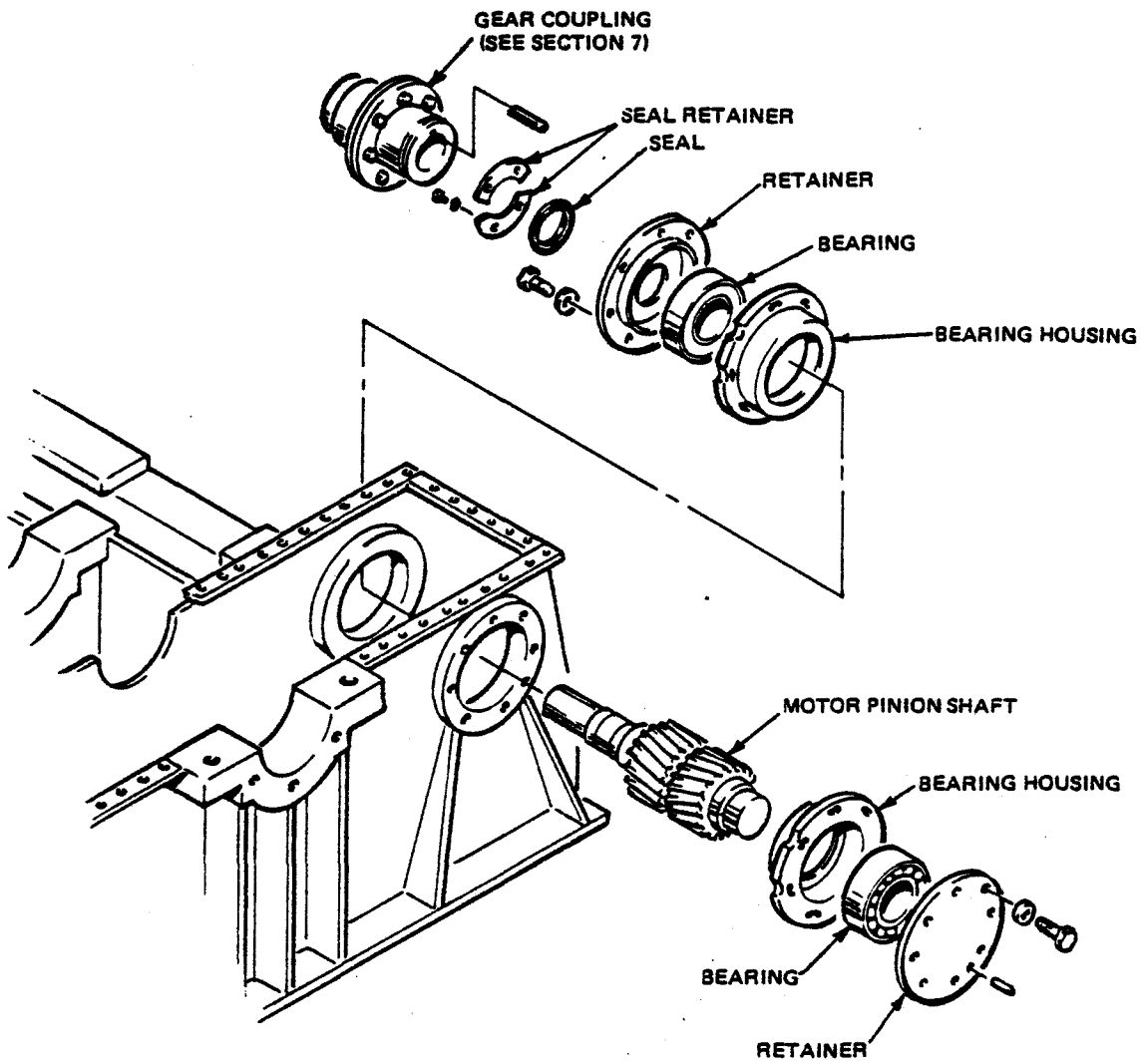

**REMOVAL OF MOTOR PINION SHAFT**

Reinstall bearing retainer, swing pinion and pinion retainer. Wire lock all cap screws (See Engineering Data, Section 7). Reinstall pinion gear guard. Close gear case drain valve and plug shaft housing drain.

Refill gear case with 190 gallons of gear oil.

If a seal is not available and a solid seal is to be installed, proceed as follows: after swing pinion has been removed, support shaft with jacks and cribbing.



**WARNING:** Do not remove bearing retainer screws without supporting shaft to prevent shaft from dropping out of mesh in gear case.



**WARNING:** Disconnect electric power to the swing motors by opening the circuit breaker and attach danger tag.

Remove house roof hatches in area over swing motor. Disconnect air line and electrical wiring and remove swing motor. Reach into gear case and screw eyebolt into end of main shaft. Attach suitable cable to eyebolt and take a strain sufficient to support shaft in installed position. Shaft weight is 1,746 pounds.

**REMOVAL OF MAIN SHAFT AND SWING MOTOR** – Swing the machine to position the swing pinion at the front of the lower frame. Open the globe drain valve and drain gear case oil into a suitable container (190 gallons). Drain the shaft housing by removing the pipe plug located in the side of the bearing housing.

Remove swing pinion guard. Support pinion on cribbing with hydraulic jacks positioned so that they will not block removal of the pinion retainer. Remove pinion retainer and lower pinion onto support cribbing.



**WARNING:** Do not remove bearing retainer screws without supporting shaft to prevent shaft from dropping out of mesh in gear case.



**WARNING:** Disconnect electric power to the swing motors by opening the circuit breaker and attach danger tag.

Remove house roof hatches in area over swing motor. Disconnect brake air line and electrical wiring and remove motor (brake and motor have combined weight of 4,080 pounds). Reach into gear case and screw eyebolt into end of main shaft. Attach suitable lifting cable to eyebolt. Remove twelve cap screws which secure bearing retainer to bearing housing at bottom of shaft. Remove retainer.

Pull shaft up and out of gear case. Bearings will come out with shaft. Shaft weight is 1,746 pounds.

CLICK HERE TO **DOWNLOAD** THE COMPLETE MANUAL

- Thank you very much for reading the preview of the manual.
- You can download the complete manual from: [www.heydownloads.com](http://www.heydownloads.com) by clicking the link below



- Please note: If there is no response to CLICKING the link, please download this PDF first and then click on it.

CLICK HERE TO **DOWNLOAD** THE COMPLETE MANUAL



**WARNING:** High voltage in this area. Turn OFF electrical power to the machine before entering this area.

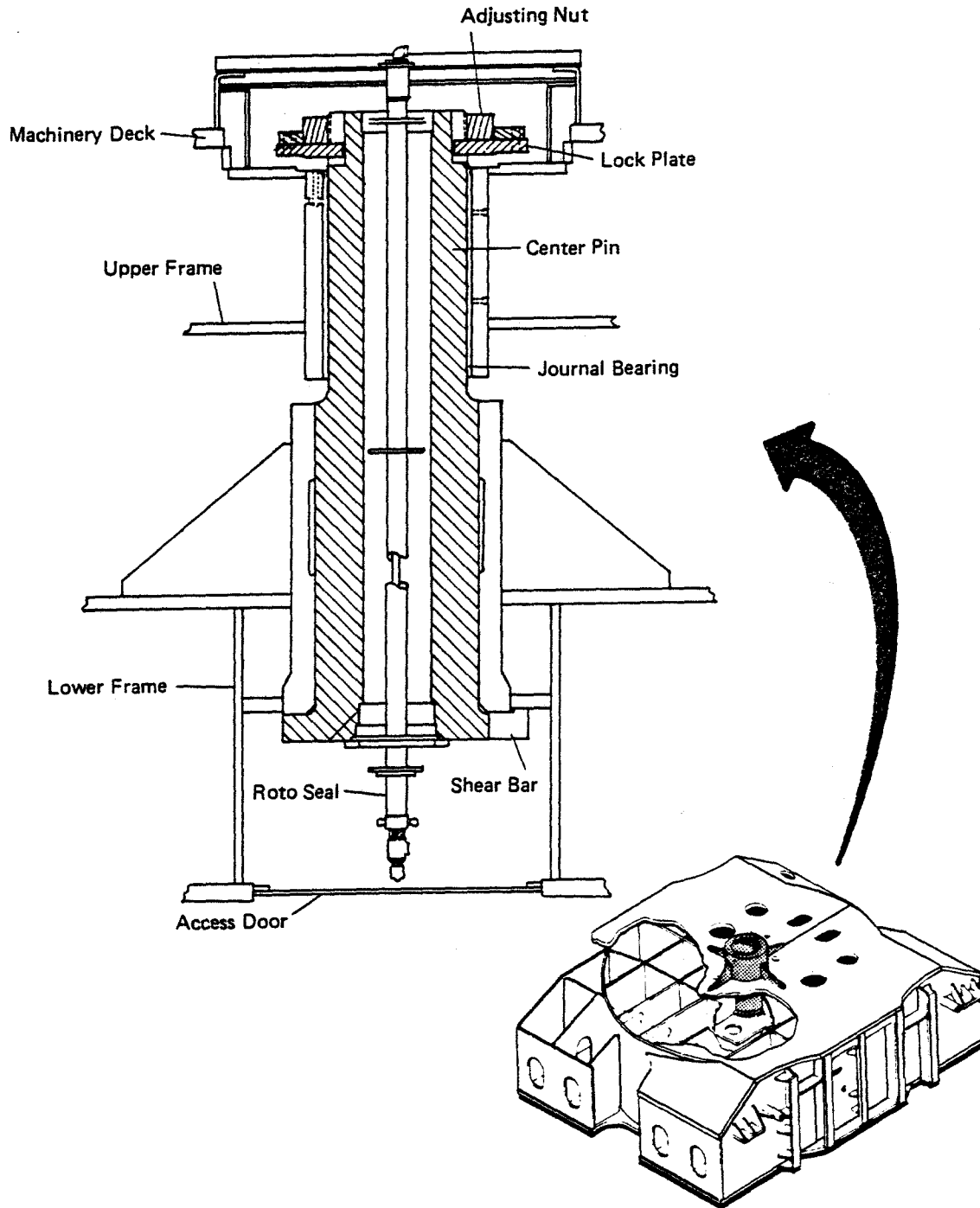

**CENTER JOURNAL**

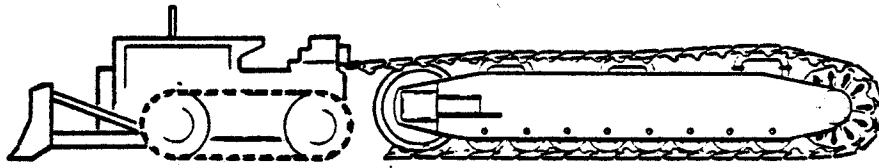

sprocket. Propel machine forward and winch belt over top of crawler side frame and slide bars. Pull belt ends together and connect with pins. Re-adjust belt tension as previously described in this section.

### REPLACEMENT OF LOAD ROLLERS –

Eight load rollers are on the bottom of each crawler side frame. These rollers distribute the weight of the machine evenly on the crawler belt. Each roller turns independently on a

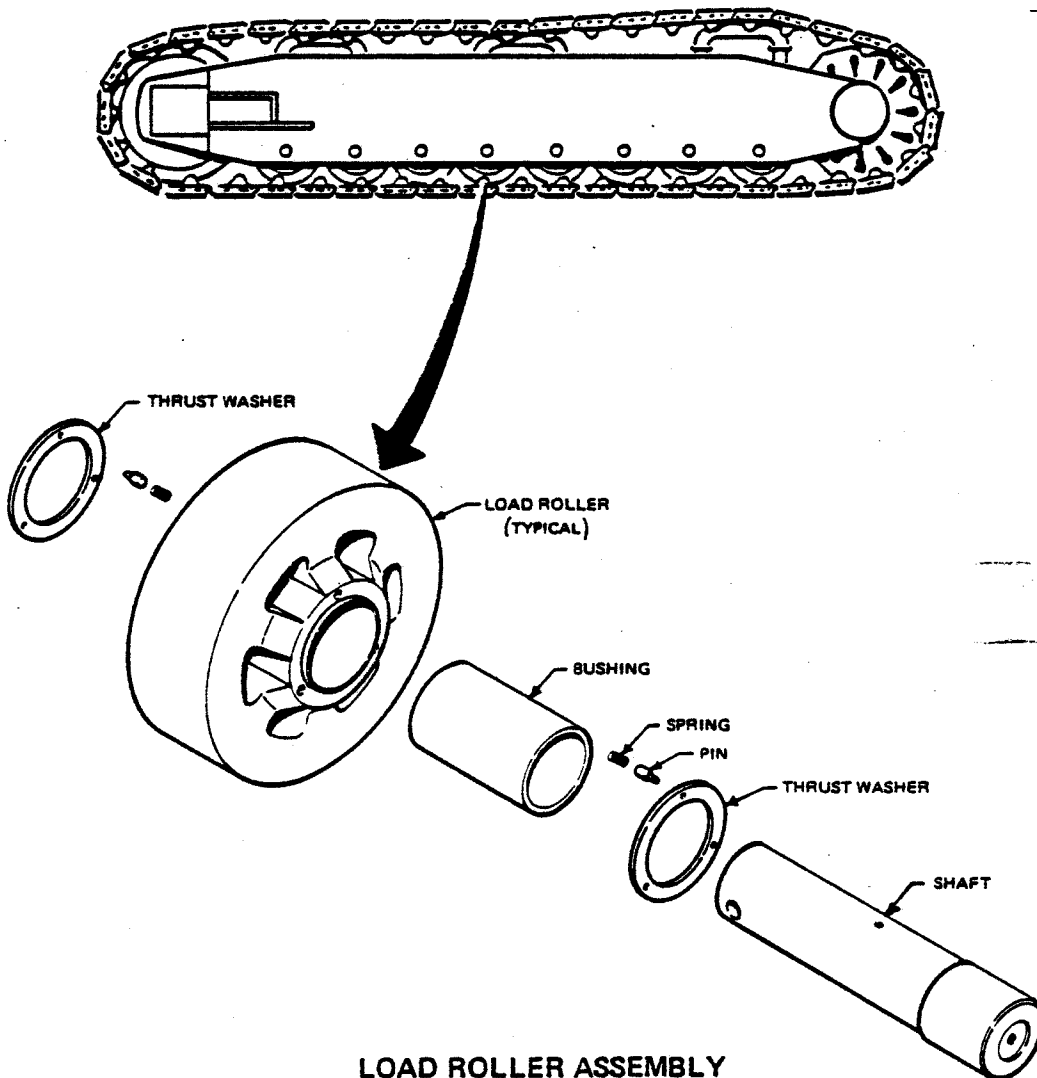

LOAD ROLLER ASSEMBLY

The first intermediate gear set consists of a large spur gear splined to a quill shaft with an integral pinion. The quill shaft turns around the main propel shaft to drive the second intermediate gear set.

The second intermediate gear set consists of a large spur gear splined to a stub shaft with an integral pinion. The pinion drives the main propel shaft gear.

The main propel shaft consists of the main propel gear and two shaft sections connected by a flanged coupling. There is a steering clutch on both ends of the main shaft. These clutches are engaged with the propel pinion shaft to propel and/or steer the machine.

The propel pinion shaft drives the propel gear which is splined to the crawler drive sprocket shaft.

To remove the propel gear case from the lower frame, first swing the machine to the side to get maximum working space above gear case. Disconnect power cable and remove cable reel from machine. Block under machine.

Pull the clevis pin from the right side steering clutch shifter fork and move the clutch ring completely off the main propel shaft clutch. Remove right hand steering shifter lever and link. Detach steering lever bracket, spring and spring retainers from the top of the gear case at the machine centerline.

Drain gear case of 120 gallons of gear lube. Separate the main propel shaft coupling at the left side of the gear case. Separate the coupling between the motor drive shaft and pinion shaft.

Crib up the gear case. The cribbing must extend far enough to allow sliding the gear case clear of the rotating frame. When clear of the frame, the gear case can be moved with a crane or other suitable lifting device. The weights of the gear case and installed main components are approximately as follows:

Gear Case Structure . . . . .	6000 lbs.
Motor Pinion Shaft . . . . .	300 lbs.
First Intermediate Shaft Assembly . . . . .	2300 lbs.
Second Intermediate Shaft Assembly . . . . .	3550 lbs.
Main Propel Shaft . . . . .	<u>6750</u> lbs.
Total Weight . . . . .	18900 lbs.

If these items are not located correctly, check the individual components against manufacturing drawing to determine problem and correct.

- B. Check the propel steer mechanism in a straight ahead travel or digging position. The steering clutch engages both the pinion shaft and the main propel shaft.

Both cylinders are de-energized and fully retracted. The 4.00 adjustment, (if necessary) is accomplished by adjusting the effective length of the cylinder bolts.

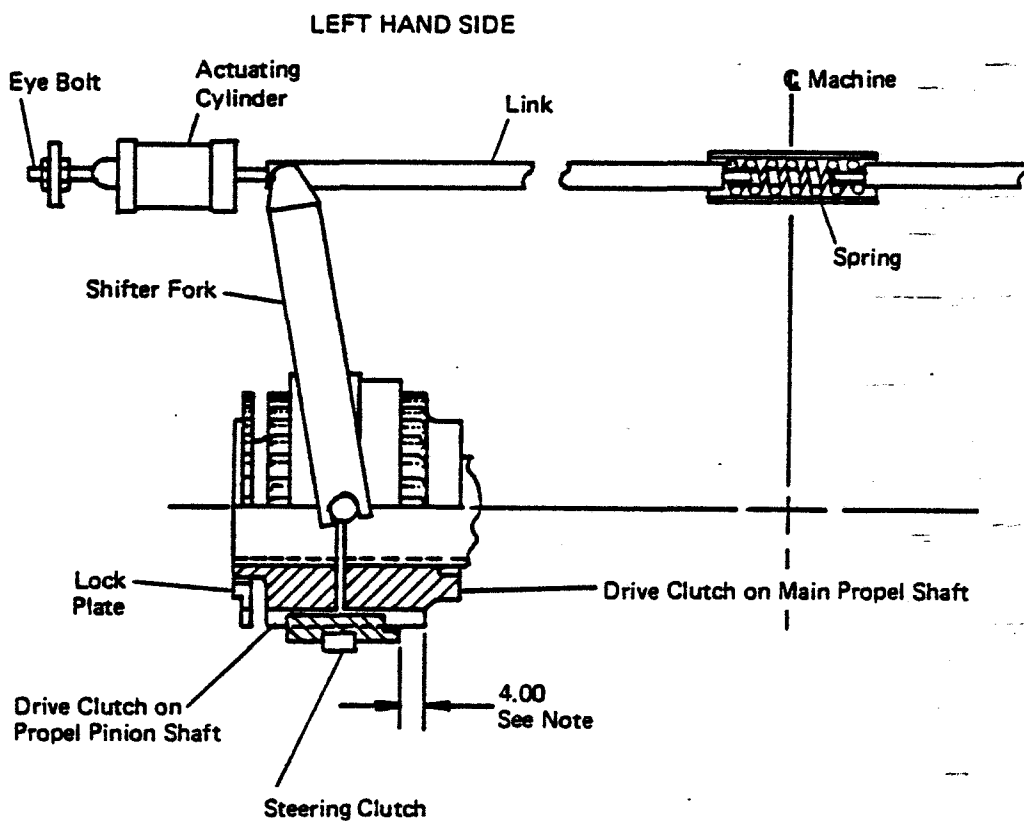

NOTE: Clutch Collar Installed With Counterbored End Toward Center of Machine.

4.00 Setup Dimension May Vary Due to Part and Assembly Tolerance.

- C. Check position of steering clutch for steering mode. Energize the left hand cylinder. The left hand steering clutch will slide to the left, fully engaging the lock plate located on the crawler side frame.

## TROUBLE SHOOTING GUIDE FOR AIR COMPRESSOR

**A. CONDITION:** Excessive noise.

**CAUSE:** Loose flywheel or motor pulley.

**REMEDY:** Tighten.

**CAUSE:** Loose valve.

**REMEDY:** Inspect valve for damage and tighten valve, both plug and cover.

**CAUSE:** If noisy only during starting check for loose belts.

**REMEDY:** Tighten until no slippage is apparent, allowing some slack.

**CAUSE:** Vibration of belt guard, piping or loose components.

**REMEDY:** Tighten.

**CAUSE:** Intercooler or aftercooler tubes out of place or not clamped securely.

**REMEDY:** Position properly and clamp tightly.

**CAUSE:** Improper level and grade of oil in crankcase.

**REMEDY:** See Lubrication of Compressor in this section.

**CAUSE:** Carbon or other foreign material on piston head.

**REMEDY:** Clean off piston tops. Inspect and clean valves.

**CAUSE:** Excessive motor or compressor shaft end play.

**REMEDY:** Check pulley or flywheel for lateral movement.

**REMEDY:** Read Item No. 1. Change oil frequently — avoid cylinder rusting and ring wear.

**O. CONDITION:** Excessive water in the air receiver or tank.

**CAUSE:** Condensation in the air receiver.

**REMEDY:** This is the natural result of compressing air and is not due to faulty equipment. This condition can be corrected by draining the air receiver daily.

**P. CONDITION:** Unloader pilot chatters or does not operate properly.

**CAUSE:** Dirt on screen in lower end of body.

**REMEDY:** Clean and repair as necessary.

**CAUSE:** Valve disc of the damaged valve seat will cause the pilot valve to chatter.

**REMEDY:** Replace pilot or parts. See Service Bulletin 31.101.

**CAUSE:** Pilot is at the bottom of the air receiver.

**REMEDY:** Install pilot valve in the center of the tank to prevent contaminants from clogging the valve.

**Q. CONDITION:** Unloader mechanism in the intake valves chatter or air pressure drops even though no air is being used. See "Automatic Unloader" under "Operation."

**CAUSE:** Broken or bent forks in compressor unloader mechanisms doesn't unload the compressor, although pilot is operating.

**REMEDY:** Repair or replace as necessary.

**CAUSE:** Dirt, chips or damaged valve plunger.

**REMEDY:** Clean and repair as necessary.

The domed end plate is disassembled by completely removing the locking screw and pulling the valve lever out of the end plate. The valve lever is located under the cover plate.

To assemble the CPR reverse the disassembly procedure. Coat the inside of the ball cup assembly and the ball cage with the crankcase oil. Heavy grease will retard the action of the CPR and should not be used.

On several compressors an adapter casting known as a pressure release housing is installed between the (CPR) and the crankcase. It is essential that the oil port for lubricating the (CPR) mechanism be pointing toward the bottom of the crankcase.

**SAFETY VALVES** — Safety valves on air receivers are set at the factory to a pressure approximately 15 lbs. higher than the rated pressure of the outfit to protect the air receiver against excessive pressure.

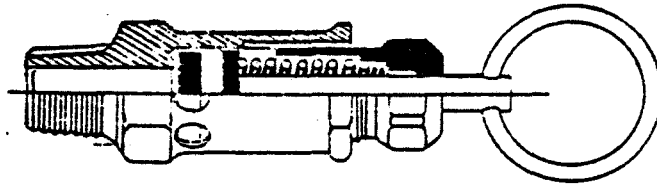

The safety valve is set at 50 to 55 lbs. on each innercooler casting. The valves serve to protect and prevent excess pressure from building up inside the innercooler. A heavy accumulation of carbon in the innercooler or possibly a carboned or leaking valve assembly in the compressor head will cause frequent popping of the safety valve. The reason for "popping" is usually not the fault of the safety valve.

**AUTOMATIC UNLOADER** — Compressors with unloaders can run constantly and maintain air pressure within set limits. The compression is removed when maximum desired pressure is achieved and the compression is automatically resumed when the minimum desired pressure is reached.

The automatic unloader is used when frequent starts and stops are impractical as with a gasoline engine or when air receiver capacity is so small, as with portable compressor outfits.

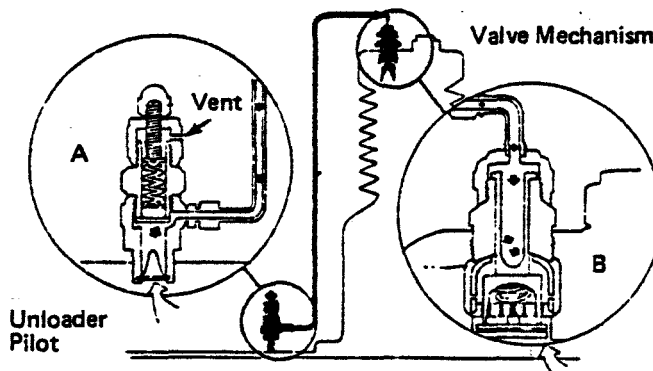

**RUNNING CLEARANCE FOR BRONZE BUSHINGS**  
All Dimensions in Inches

Nom. Diam.	Shaft		Running Clearance	Nom. Diam.	Shaft		Running Clearance
		O.D.				O.D.	
1	1.000	.006	.010	5	5.000	.011	.020
	.999				4.998	.020	
1-1/4	1.250	.005	.010	5-1/4	5.250	.011	.020
	1.249				5.248	.020	
1-1/2	1.500	.008	.013	5-1/2	5.500	.012	.020
	1.499				5.498	.020	
1-3/4	1.750	.008	.013	5-3/4	5.750	.012	.021
	1.749				5.748	.021	
2	2.000	.007	.012	6	6.000	.012	.021
	1.999				5.998	.021	
2-1/4	2.250	.006	.013	6-1/4	6.250	.012	.021
	2.248				6.248	.021	
2-1/2	2.500	.006	.013	6-1/2	6.500	.012	.021
	2.498				6.498	.021	
2-3/4	2.750	.008	.015	6-3/4	6.750	.013	.022
	2.748				6.748	.022	
3	3.000	.008	.015	7	7.000	.013	.022
	2.998				6.998	.022	
3-1/4	3.250	.008	.015	7-1/4	7.250	.013	.022
	3.248				7.248	.022	
3-1/2	3.500	.008	.015	7-1/2	7.500	.014	.022
	3.498				7.498	.022	
3-3/4	3.750	.011	.019	7-3/4	7.750	.016	.024
	3.748				7.748	.024	
4	4.000	.011	.019	8	8.000	.015	.024
	3.998				7.998	.024	
4-1/4	4.250	.010	.019	8-1/4	8.250	.015	.024
	4.248				8.248	.024	
4-1/2	4.500	.010	.019	8-1/2	8.500	.016	.025
	4.498				8.498	.025	
4-3/4	4.750	.014	.022	8-3/4	8.750	.016	.025
	4.748				8.748	.025	

Tighten nuts progressively from fixed edge to free edge. This achieves tension and prevents loosening under most severe conditions.

**TORQUE METHOD:** The recommended torque values listed in the following TABLE apply to non-plated fasteners as received from manufacturer with no special lubricants applied.

Also, the values are based on "Unified Course" threads.

### TORQUE VALUES

Fastener Dia. (in.)	Grade 5		Grade 8		Hex Socket Head	
	Ft.-Lb.	Nm	Ft.-Lb.	Nm	Ft.-Lb.	Nm
5/16 - .31	17	23	24	33	38	52
3/8 - .38	30	41	43	58	50	68
7/16 - .44	48	65	70	95	80	109
1/2 - .50	75	102	105	142	125	170
5/8 - .62	150	203	210	285	240	325
3/4 - .75	265	359	375	509	425	576
1 - 1.00	645	875	905	1,227	1,015	1,376
1-1/4 - 1.25	1,200	1,519	1,820	2,468	2,050	2,780
1-1/2 - 1.50	1,950	2,644	3,160	4,285	3,565	4,834
1-3/4 - 1.75	2,285	3,098	4,990	6,766	5,600	7,593
2 - 2.00	3,440	4,664	7,500	10,170	8,450	11,458
2-1/4 - 2.25	5,030	6,820	10,970	14,875	12,350	16,746
2-1/2 - 2.50	6,875	9,322	15,000	20,339	16,875	22,881
2-3/4 - 2.75	9,320	12,637	17,800	24,136	22,900	31,051
3 - 3.00	12,315	16,698	23,510	31,878	30,225	40,983

the strand or perpendicular to the rope center. Lang lay provides a greater area of wire to resist abrasion. The internal friction of lang lay rope is less also.

Wire rope with independent wire rope core (IWRC) offers substantially greater support to rope interior and resists crushing or distortion when rope pulls over a sheave or drum.

The proper fit of the sheave and spiral drum groove supports the rope and prevents creating an elliptical shape as rope bends around sheave or drum.

The final wire rope selection for any particular application on excavators requires the balance of several characteristics that satisfies the greatest number of needs.

The vulnerability to abuse and mishandling may cause a new rope permanent damage during installation. Improper removal from reel or coil often causes kinks. Pulling on rope until loop radius reduces to point where rope wire bends beyond the metal elastic limit creates these kinks. Pulling rope over a small sized sheave causes a kink also. Even when kink appears straightened, the strand damage and weakness remains.

Abrasion or nicks caused by pulling a rope over sharp objects weakens the rope. Wire rope needs protection from possible damage when a winch or lifting device attaches to strands forming a dogleg bend in the rope.

A coil of rope correctly unwound is rolled, (like a hoop), along a smooth surface and away from the rope end.

When removing rope from reel, place a heavy shaft or pipe thru reel center and raise until reel turns freely. Allow this free turning as rope end is carried straight away from the reel. Use a wedge block or plank against the flange to act as a brake. Whenever possible, transfer rope directly from reel to drum. (See sketch). In case of overwind, transfer rope from top of reel to top of drum. Likewise, for underwind; transfer rope from bottom of reel to bottom of drum. Avoid any methods where a reverse bend in rope might occur.

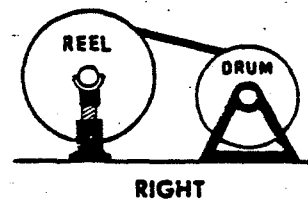
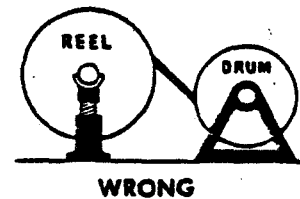

A good operator and maintenance crew develops the habit of watching ropes during work cycle to determine any damage in rope appearance caused by accident, broken wires, etc. Inspection determines, by careful measurement and comparison with a new rope, any loss in rope diameter. This loss at isolated spots indicates core failure. Where core failure occurs, the rope collapses and lay length (one full strand wrap) increases.

Diameter loss over a large area indicates normal outer wire wear. Wires wear more rapidly

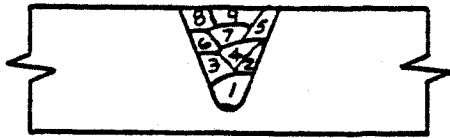

Use a small diameter rod in crack base. Larger diameter rod or semi-automatic application may be used if FULL access to previous weld deposit can be obtained. Weld bead sequence is shown in sketch. AVOID applying wide beads or using a weaving technique.

is shown in sketch. AVOID applying wide beads or using a weaving technique.

- d. Repair cracks with overall dimension of eight to twelve inches in length with the V out method, starting at one end and continuing to the middle. Repair this opened area as in (c.) mentioned before; except that each succeeding layer applies in a cascade manner. In other words, each succeeding layer of deposited weld is shorter at starting point. This permits proper tie-in of weld beads when the remaining portion of crack is opened up and repaired. NOTE: TAPER ends of ALL areas V-ed out. This allows proper fusion and access to the parent metal.

- e. For cracks with dimensions OVER twelve inches.

Where possible, V out middle one-third of repair area to base of crack. Complete the repair of this area with each successive layer applied in a cascade manner on both ends.

After center portion is repaired, V out either of remaining ends. Taper end of V out for proper fusion and access. Complete weld of this area.

Complete weld on final one-third of repair area.

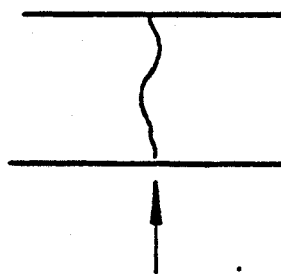
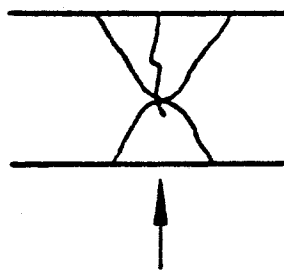
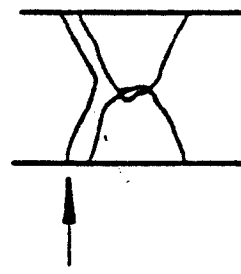

Plate or Casting Crack



Center Bead Crack



Fusion Line Crack

- f. After arc out, magnaflux the joint to determine if ALL the crack has been removed. Give particular attention to bevel walls, since cracks have different patterns and it is possible the arc out may appear free of cracks; when actually it is not.

**PROPER PREPARATION FOR WELDING** is half the job. V out defective material, so repair weld will be as thick as original metal. REMOVE slag, rust, grease, paint, water, etc., from repair area. ALIGN parts

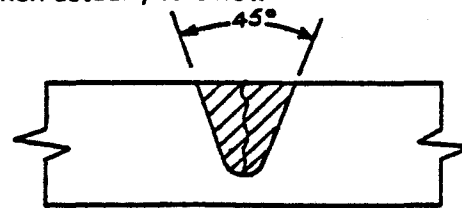

Crack completely removed gives satisfactory repair

DO NOT USE pointed, sharp-edged or hardened steel tools (screwdrivers, church keys or knives) for removal or installation of backup rings or seals. Soft-metal tools of brass or aluminum, plastic, wood or phenolic rod when formed into desired shape save the critical surfaces.

Tool surfaces need to be well rounded, polished and no burrs on working end. This obviously prevents scratches.

Removal from cylinders and pistons means every effort is needed to avoid contact with machined surfaces.

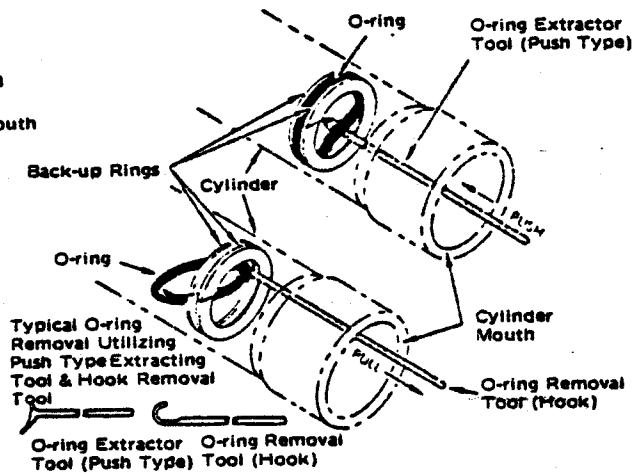
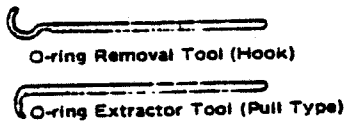
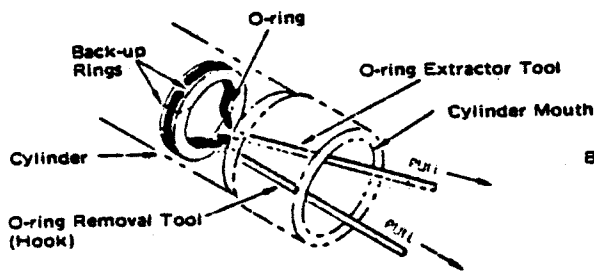

Typical O-ring Removal Utilizing Push Type Extracting Tool & Hook Removal Tool

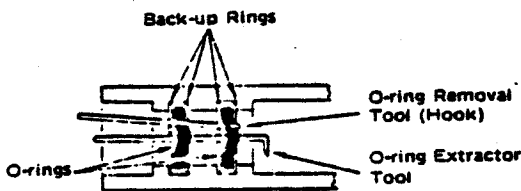

Typical Dual O-ring Internal Extraction & Simultaneous Removal

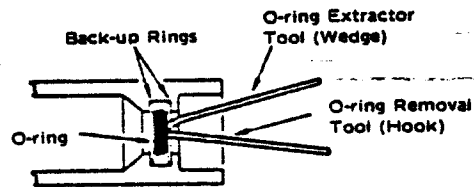

Typical Single O-ring Internal Extraction Utilizing Wedge Type Extracting Tool & Hook Removal Tool

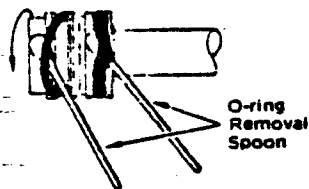

Typical External O-ring Removal Utilizing O-ring Removal Spoon

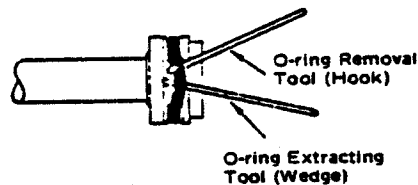

Typical Single O-ring Removal Utilizing Wedge Type Extracting Tool and Hook Type Removal Tool

CAUTION: Do Not Permit Unnecessary Contact of Tools With Bearing and Cylinder Wall Surfaces. Avoid Dropping Tools Into Cylinders

NOTE: After O-ring is Dislodged from Groove, Hold Spoon Tool Stationary Simultaneously Rotate and Withdraw Piston from Ring

# FALK COUPLING TYPE G AND GV

## G TYPE INSTALLATION

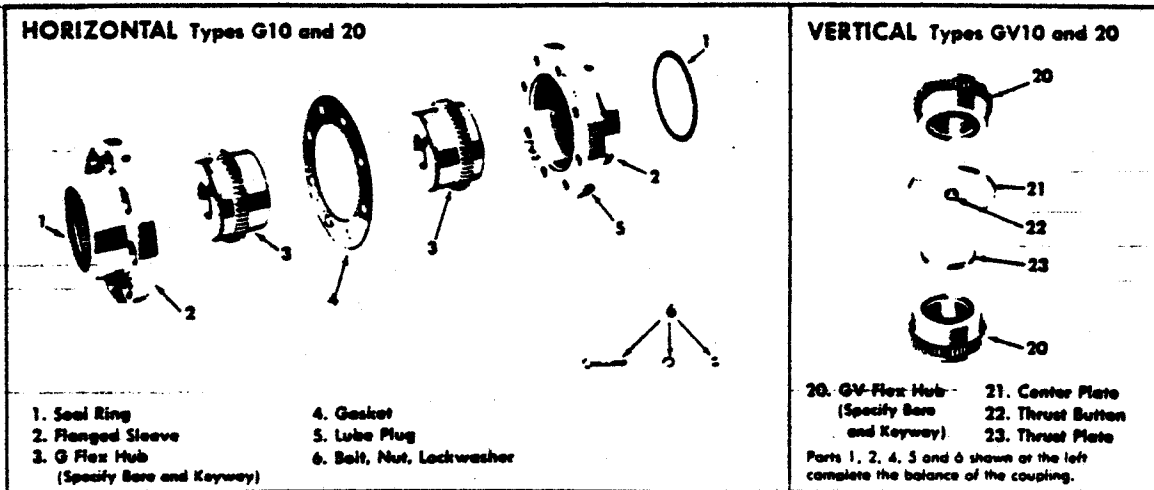

1. Clean all parts. Heat hubs in an oil bath or oven to a maximum of 275 degrees F. (135 degrees C.). DO NOT rest gear teeth on container bottom or apply a flame directly to gear teeth.

Pack sleeve teeth with grease and lightly coat seals with grease BEFORE assembly. DO NOT use cup grease. DO NOT DAMAGE SEALS.

Use a dial indicator to align dynamically balance couplings and assembly parts with mating match marks aligned. Mount indicator on one hub and take readings for OFF-SET check on O.D. of other hub. The difference between minimum and maximum readings DIVIDED by two should not exceed the values in Table. For ANGULAR check, take readings on either face of other hub. The difference between the minimum and maximum readings should not exceed the values in Table.

2. MOUNT FLANGED SLEEVES, SEAL AND HUBS—Place flanged sleeves WITH seal rings on shafts before mounting hubs. CAUTION: DO NOT DAMAGE SEALS. Mount hubs on respective shafts, as shown so each hub face is flush with its shaft end. Position equipment in approximate alignment with approximate gap specified in Table.



**2 MOUNT FLANGED SLEEVES, SEALS AND HUBS**

## DAILY ELECTRICAL INSPECTION

1. Check following bearings:
  - a. Hoist motor bearings
  - b. Swing motor bearings
  - c. Fan blower bearings
2. Are all contactors operating properly?
3. Are all lights operating properly?
4. Are all motors commutating properly?
5. Is the air conditioner operating properly?
6. Is the air filtering system operating O.K.?
7. Are all warning systems operating properly?
8. Visually examine operator controls:
  - a. Are the main controllers working O.K.?
  - b. Are the auxiliary controls working O.K.?
9. Is all electrical equipment clean and dry?

## **WEEKLY MECHANICAL INSPECTION**

### **HOUSE**

- 1. Are all panels in place and undamaged?**
- 2. Are roof arches in good condition?**
- 3. Are all windows intact?**
- 4. Any leaks in the house?**
- 5. Are all house bolts in place and tight?**

CLICK HERE TO **DOWNLOAD** THE COMPLETE MANUAL

- Thank you very much for reading the preview of the manual.
- You can download the complete manual from: [www.heydownloads.com](http://www.heydownloads.com) by clicking the link below



- Please note: If there is no response to CLICKING the link, please download this PDF first and then click on it.

CLICK HERE TO **DOWNLOAD** THE COMPLETE MANUAL