



59HR

BLAST HOLE DRILL

MAINTENANCE

and OPERATION

MANUAL

Manual No.
10424
SN: 141171

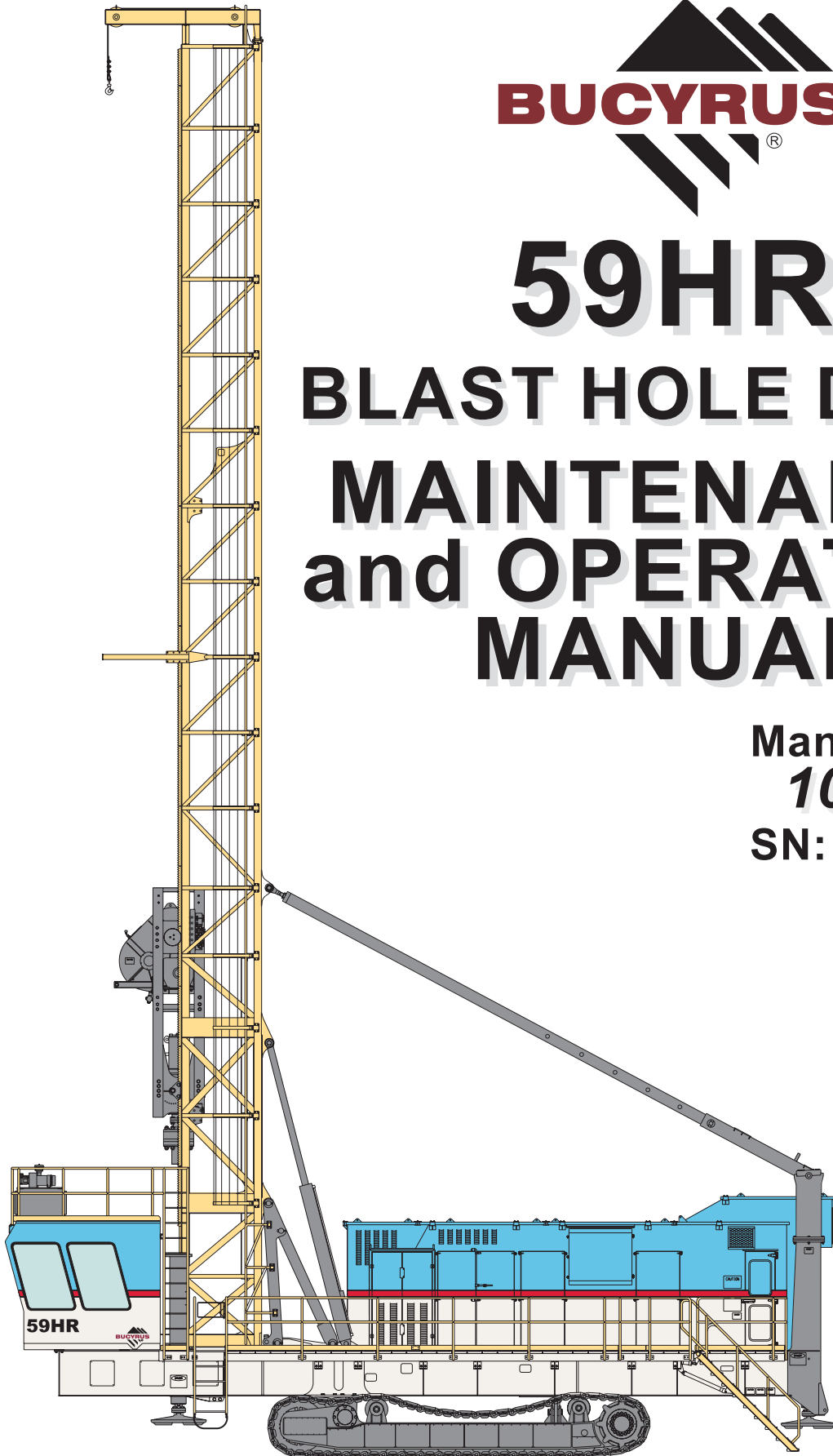

141171mc.cdr Pg. 1

141171cl

Bucyrus International, Inc.

1100 Milwaukee Ave. • P.O.Box 500 • South Milwaukee, Wisconsin 53172-0500 USA

CLICK HERE TO **DOWNLOAD** THE COMPLETE MANUAL

- Thank you very much for reading the preview of the manual.
- You can download the complete manual from: www.heydownloads.com by clicking the link below



- Please note: If there is no response to CLICKING the link, please download this PDF first and then click on it.

CLICK HERE TO **DOWNLOAD** THE COMPLETE MANUAL



SAFETY PRECAUTIONS

General Precautions:

- The employment of qualified maintenance personnel, through a scheduled maintenance program, is the best way to minimize machine downtime and maximize productivity of equipment.
- Keep hands, feet, and clothing away from rotating parts.
- Wear a hard hat, safety shoes and protective lenses at all times.
- Replace any and all safety and warning placards if they are defaced or removed from the machine.
- Think before you act. Carelessness is one luxury the service man cannot afford.
- Excessive or repeated skin contact with sealants or solvents may cause skin irritation. In case of skin contact refer to the Material Safety Data Sheet (MSDS) for that material and the suggested method of cleanup.
- Inspect safety catches (keepers) on all hoist hooks. Do not take a chance, the load could slip off of the hook if they are not functioning properly.
- If a heavy item begins to fall, let it fall, don't try to catch it.
- Keep your work area organized and clean. Wipe up oil or spills of any kind immediately. Keep tools and parts off of the ground. Eliminate the possibility of a fall, slipping or tripping.
- Floors, walkways and stairways must be clean and dry. After fluid draining operations be sure all spillage is cleaned up.
- Electrical cords and wet metal floors make a dangerous combination.
- Regularly inspect for any loose bolts or locking devices and properly secure them.
- Use extreme caution while working near any electrical lines or equipment whether it be high or low voltage. Never attempt electrical repairs unless you are qualified.
- Check limit switches for proper operation.
- After servicing, be sure all tools, parts or servicing equipment are removed from the machine and secured in an appropriate storage area.
- Mechanical Brakes are designed for use as static holding brakes only. Use as a motion (dynamic) brake in emergency situations only.
- Use proper interior and exterior lighting.
- Install and maintain proper grounding and ground fault protection systems.
- Perform functional tests of all safety circuits.
- Allow electrical inspection and maintenance to be performed only by a qualified electrician.
- Use extreme caution when working around drilled holes.



MACHINE SPECIFICATIONS

DIMENSIONS:

• Hole Diameter	10 3/4" To 17 1/2"	(273-444mm)
• Hole Depth (Single Pass)	60'-00"	(18.29M)
A Ground to Top of Deck	7'-2"	(2.18M)
B Ground to Bottom of Rear Jack Pads	1'-9"	(0.53M)
C Ground to Top of Machinery House	15'-8"	(4.77M)
D Ground to Top of Machinery House Pressurizing Unit	17'-4"	(5.28M)
E Ground to Top of Cable Reel	10'-9"	(3.28M)
F Ground to Bottom of Front Jack Pads	2'-2"	(0.66M)
G Diameter of Jack Pads	3'-8"	(1.12M)
H C/L Hole to C/L Rear Jacks	0'-0"	(0.0mm)
I Overall Length of Crawlers	25'-5"	(7.75M)
J C/L Rear Jacks to C/L Front Jacks	41'-8"	(12.70M)
K Overall Length of Machine without Cable Reel	53'-2"	(16.21M)
L Overall Length of Machine with Cable Reel	65'-0"	(19.81M)
M Overall Length of Machine with Mast at Rest	106'-7"	(32.49M)
N Ground to High Point with 60 Ft. (18.29m) Mast at Rest	31'-6"	(9.60M)
O Overall Width of Machine	25'-1"	(7.65M)
P C/L Machine to Left Side	12'-10"	(3.91M)
Q C/L Machine to Right Side	12'-3"	(3.73M)
R C/L Machine to Left Outside Edge of 36 Inch (914mm) Track	11'-4.5"	(3.47M)
S C/L Machine to Right Outside Edge of 36 Inch (914mm) Track	10'-6.5"	(3.21M)
• C/L Machine to C/L Left Rear Leveling Jack	7'-9"	(2.36M)
• C/L Machine to C/L Right Rear Leveling Jack	7'-9"	(2.36M)

WEIGHTS:*

BASIC MACHINE	350,000 lbs.	(158,730 kg)
AVERAGE WORKING WEIGHT	405,000 lbs.	(183,673 kg)

(*) Type and number of machine options will affect weight.

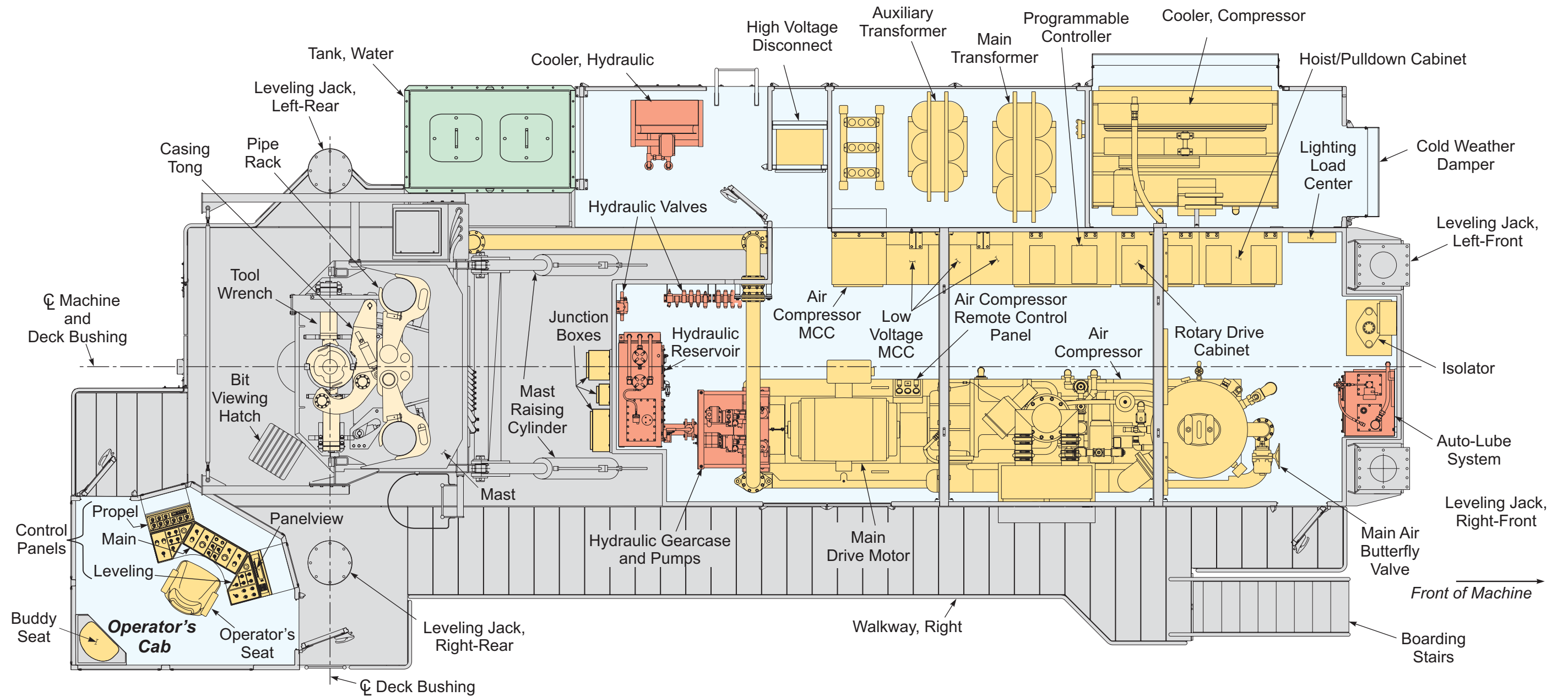

59HR Deck Plan
 LOT 14, SN: 141171
141171_D.cdr



OPERATION NEAR ELECTRICAL TRANSMISSION LINES

Permission to reproduce the following material has been granted by the Construction Industry Manufacturers Association (CIMA). CIMA assumes no responsibility for the accuracy of this reproduction.



CAUTION: The following precautions shall be complied with whenever operating near electrical transmission lines.

Working in the vicinity of electrical power lines presents a very serious hazard and special precautions must be taken. For purposes of this manual you are considered to be working in the vicinity of power lines when the machine, in any position, can reach to within the minimum distance specified by local, state and federal regulations.

Safe operating practices require that you maintain the maximum possible distance from the lines and never violate the minimum clearances.

Be certain to comply with all local, state and federal regulations regarding working in the vicinity of power lines.

Before working in the vicinity of power lines, always take the following precautions:

1. Always contact the owners of the power lines or the nearest utility before beginning work.
2. You and the electric utility representative must jointly determine what specific precautions must be taken to insure safety.
3. It is the responsibility of the user and the electric utility to see that the necessary precautions are taken.
4. Consider all lines to be power lines and treat all power lines as energized even though it is known that the power is shut off and the line is visibly grounded.
5. Slow down the operating cycle. Reaction time may be too slow and distances may be misjudged.
6. Caution all ground personnel to stand clear of the machine at all times.
7. Use a signal person to guide the machine into close quarters. The sole responsibility of the signal person is to observe the approach of the machine to the power line. The signal person must be in direct communication with the operator and the operator must pay close attention to the signals.



CAUTION: Death or serious injury could result should any part of the drill come within the minimum distance specified of an energized power line.

OPERATOR'S CONTROL CONSOLE

NOTE: The controls on the operators console are all electric. The switches operate electric controls, electromechanical or electrohydraulic valves on the machine. For purpose of describing the controls, the console will be broken down into panels and the controls on each panel described. The panels of the console are: main controls, propel controls, selector switches, leveling controls and Operator's display terminal.

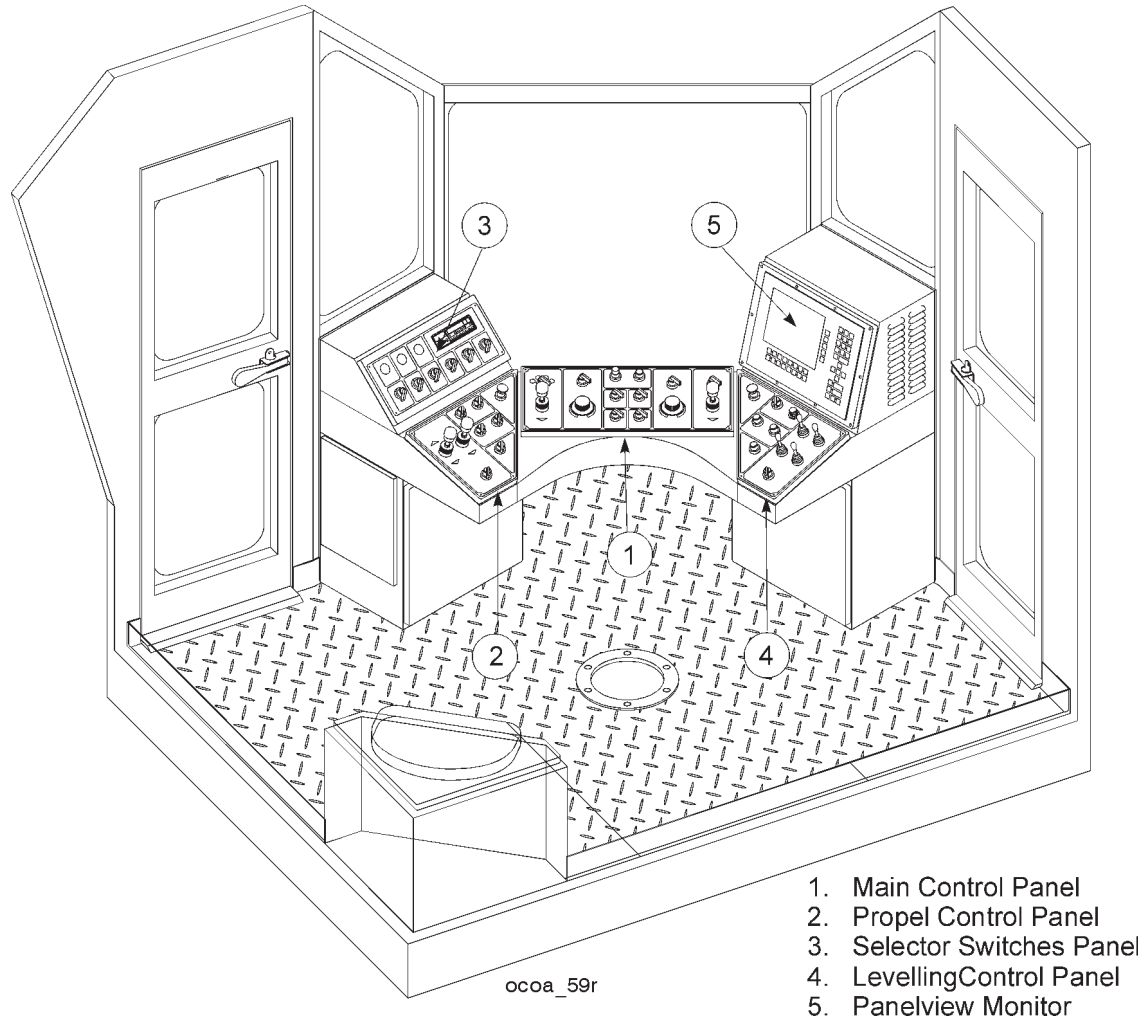

Operator's Control Console - Overall View

NOTE: The panels with controls as shown on the following pages are typical of what could be included on a console. Individual machines will vary depending upon customer requirements.



BREAKOUT WRENCH SWITCH

The breakout wrench switch (1) is a three-position spring-return switch. Turning the switch to the EXTEND position will cause the breakout wrench to extend, grip the pipe and turn, breaking the pipe joint. Turning the switch to the RETRACT position will retract the breakout wrench arm and then retract the breakout wrench, away from the pipe.

PIPE POSITIONER SWITCH

The pipe positioner switch (2) is a three-position spring-return switch. Turning the switch to the OVER HOLE position will retract the positioner alignment cylinders. When fully retracted it will then extend the positioner jaw cylinder to clamp the drill pipe. Turning the switch to the STORE position will retract the jaw cylinder, then extend the positioner alignment cylinders. This switch is functional whenever the hydraulic pumps are running.

DUST SEAL SWITCH

This is a three-position spring-return switch (3) which is used to initiate movement of the drill deck dust seal. Turning the switch to the rear position will cause the dust seal mechanism to move toward the rear of the machine. Turning the switch to the forward position will cause the dust seal mechanism to move toward the front of the machine. This switch is functional whenever the hydraulic pumps are running, and is only used on machines with the angle hole drilling package.

A-FRAME LOCK SWITCH

The A-frame lock switch (4) is a three-position spring-return switch. Turning the switch to the LOCK position will extend the A-frame lock pin cylinder. Turning the switch to the UNLOCK position will retract the cylinder. For this switch to be functional, the hydraulic pumps must be running, the mast/winch selector switch must be in a vertical position with mast lock pins in place. When the machine is drilling at an angle, these pins are in the UNLOCKED position. This switch is only used in machines equipped with the angle hole drilling package.

MAST BRACE LOCK SWITCH

The mast brace lock switch (5) is a three-position spring-return switch. Turning the switch to the LOCK position will extend the mast brace lock pin cylinder. Turning the switch to the UNLOCK position will retract the cylinder. For this switch to be operable, the hydraulic pump must be running and the mast/winch selector switch must be in the MAST position. This will allow the switch to function in the LOCK position. To function in the UNLOCK position, the rotary head assembly must be at the lower limit point. This additional restriction, of having the rotary head assembly at the lower limit, is not required for machines with the angle hole drilling feature.

MISCELLANEOUS CONTROLS

Located about the machine are various miscellaneous controls and monitors which would be used with optional equipment or do not fit in the previously described groups.

The portable remote propel station is located in an enclosure under the operator's cab on the right side of the machine. In addition to storing the portable station the enclosure includes 40 feet of cable and an enabling switch to energize or de-energize the station. Another enabling switch and plug in socket are located at the front right corner of the drill main frame. The station includes two joysticks, one for each crawler frame; an emergency stop pushbutton; a propel speed selector; and a red indicator which will light up when the station is energized.

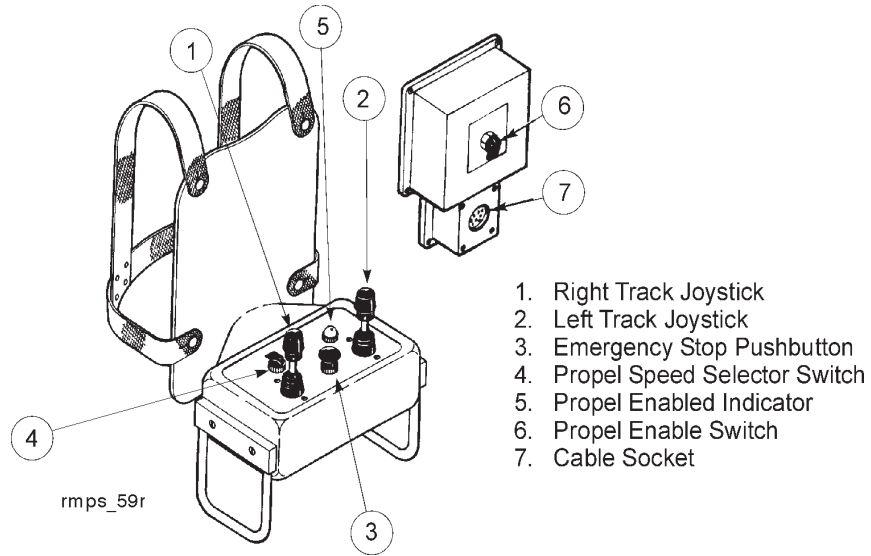

Portable Remote Propel Station (Optional)

The hydraulic reservoir remote fill control panel is used to monitor the reservoir as it is being filled. The instructions for use of these controls are printed directly below the controls.

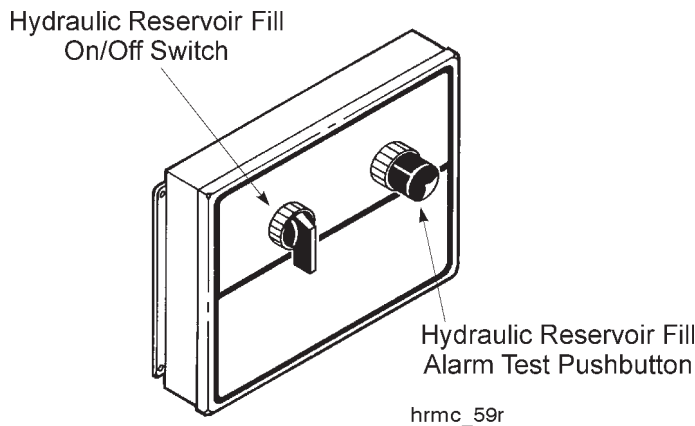

Hydraulic Reservoir Remote Fill Control Panel

TOWING PROCEDURE



CAUTION: Be sure crawlers are securely blocked before disengaging gearbox clutch for towing.

1. Secure the machine by blocking crawlers.
2. Secure the tow bar to the towing vehicle.

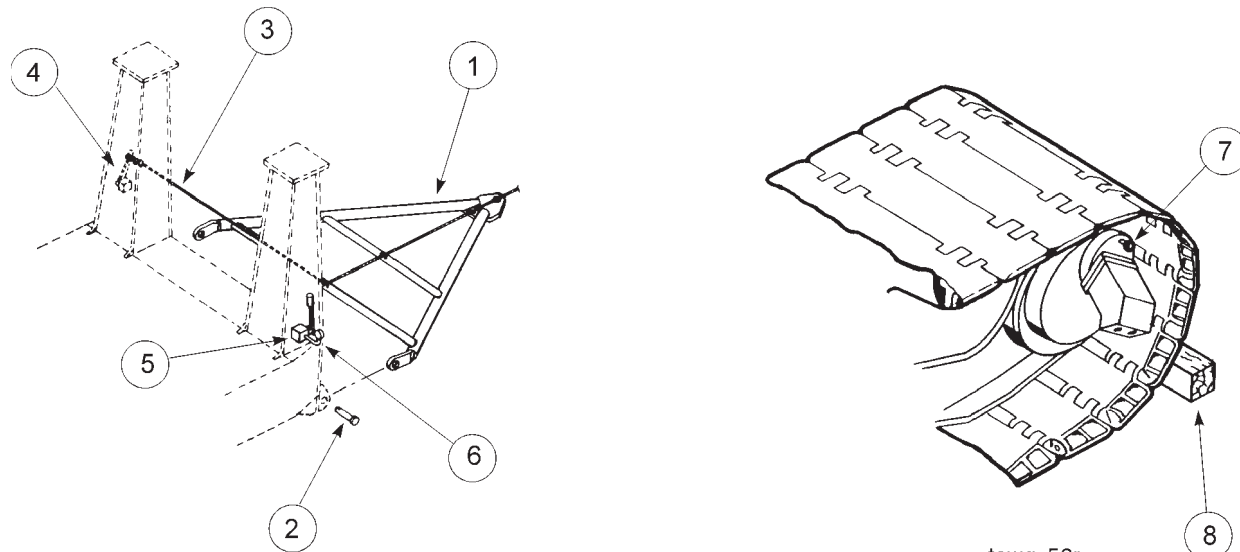

1. Tow Bar
2. Tow Bar Pin
3. Lanyard
4. Safety Valve
5. Hand Pump
6. Hydraulic Pressure Gauge
7. Gearbox Disengaging Knob
8. Blocking

3. Fasten a lanyard to the towing safety valve lever. The valve is mounted to the left front jack casing. Run the lanyard down the casing, along the tow bar and secure it to the towing vehicle. If during towing the tow bar should come loose from either the drill or the towing vehicle, the lanyard will trip the safety valve and set the drill propel brakes.
4. Disconnect the drive tumbler gearbox from the propel motor as follows:
 - a. Ensure that the propel pump controls are in neutral position
 - b. Loosen shifter lever lock screw
 - c. Pull out shifter lever to disengage clutch
 - d. Tighten shifter lever lock screw

3. To hoist the auxiliary winch line, lift and move the mast/winch joystick, located on the main control panel, forward. To stop the line, return the joystick to the NEUTRAL position.
4. To lower the winch line, lift and move the joystick rearward. To stop the line, return the joystick to the NEUTRAL position.

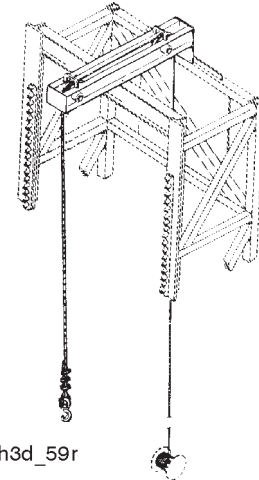

PIPE RACK OPERATION

The machine can be equipped with 1 to 4 pipe racks and depending upon the number of pipe racks the pipe rack configuration and operation will be different.

- On a machines with one pipe rack, the rack will be on a swing out arm and will be in #1 position .
- On a machine with two pipe racks, the racks will be on swing out arms and will be in #1 and #4 positions.
- On a machine with three pipe racks, two pipe racks will be located on a carousel that swings out and then is rotated. This carousel houses pipe racks in #1 and #2 positions as shown. The third pipe rack is a swing out rack that will be in #4 position.
- On a machine with four pipe racks, there are two swing out carousels with two racks in each carousel. The carousels rotate to make each rack available for use. The left carousel houses racks #1 and #2 and the right carousel racks #3 and #4.

10. Once the pipe rack has been stored the pipe should be cleaned out using the bailing air. Remove all personnel from the area and turn on the bailing air for a moment. After cleaning the pipe, clean and lubricate the threads and shoulder on the lower end of the pipe and the upper end of the stabilizer.



CAUTION: Before working around the tool string set the hoist brake. Depress the drill/propel control OFF pushbutton.

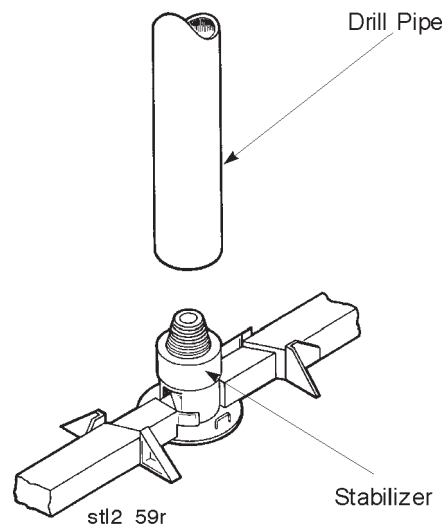

Stabilizer Installation

11. Release the hoist brake and lower the rotary/pulldown unit until the drill pipe is approximately 1 foot above the upper end of the stabilizer. Reset the hoist brake.
12. Turn the rotary rheostat clockwise until the drill pipe begins to turn at approximately 5 RPM as shown on operator's display terminal operator's display screen. Release the hoist brake and carefully lower the rotary drive unit until the drill pipe contacts the stabilizer. Allow the rotary drive unit to continue to lower under gravity while the drill pipe is threading onto the stabilizer.
13. When the stabilizer begins to turn with the drill pipe, check the joint between the stabilizer and the pipe. The shoulders on the pipe and stabilizer must be together. If there is clearance between the shoulders, it will be necessary to tighten the joint some more before the stabilizer is released. If the shoulders of the pipe and stabilizer are contacting, the joint is made up.

Installation of the drill bit is the last step in preparing the tool string.

59HR ELECTRIC BLAST HOLE DRILL

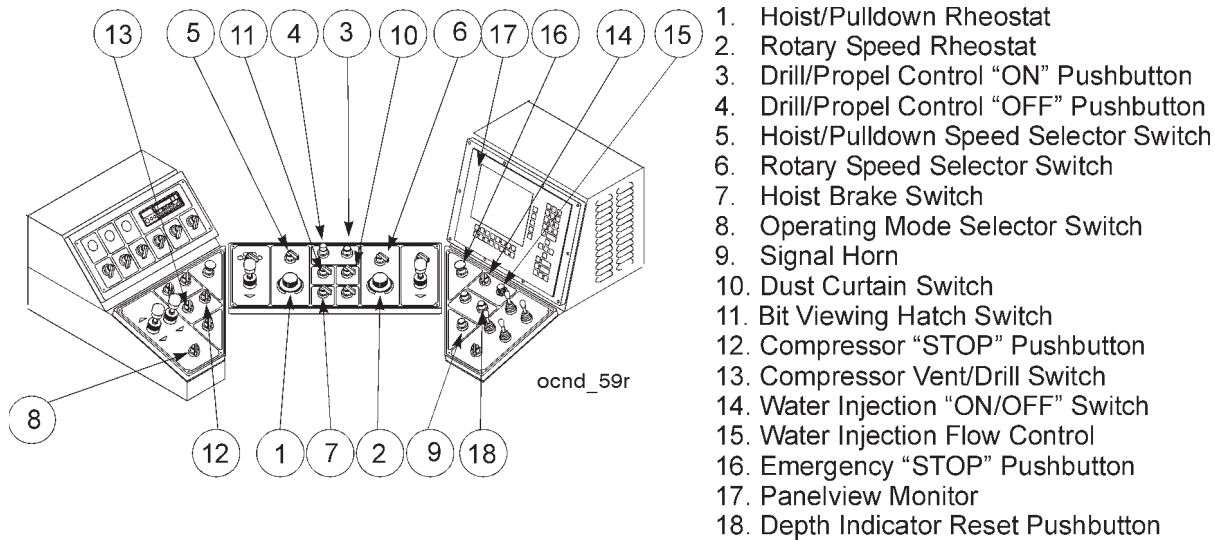
*Controls for Normal Drilling*

During the actual drilling the operator's display terminal should be turned on and the operator display screen shown on the monitor. All of the drilling parameters noted in the following paragraphs will appear on the operator's display screen.

NOTE: The bar graphs on the operator's screen on the operator display terminal shows the condition of each of each functions. If a function operates beyond its normal operating range, especially for rotary current and hoist/pulldown force, the bar graph color will change from green to yellow or red when the graph valve raises into that particular range. For details, refer to the Operator Display Manual.

STARTING THE HOLE (COLLARING)

Since the first few feet of a hole are usually in unconsolidated material, the procedure for drilling through this material will be different than for the remainder of the hole. This procedure is commonly referred to as collaring the hole.

To begin, or collar the hole, proceed as follows:

1. Verify that the tool wrench and breakout wrench are retracted fully. Clear the drill deck of personnel and material which is not necessary for the drilling procedure (i.e. oil drums, tools, spare bits, etc.).
2. Place the operating mode selector switch in the DRILL position. Place the hoist/pulldown speed selector switch in the PULLDOWN position. Depress the drill/propel control ON pushbutton. Release the hoist brake and allow the tool string to lower so that the guide bushing is firmly seated in the hole in the drill deck. Make sure that the slots in the bushing align with



5. Press the drill/propel control ON pushbutton.
6. Place the compressor vent/drill switch in the DRILL position.
7. Verify on the operator's display terminal that no PDC faults exist. If a fault exists, it must be cleared before the PDC control can be activated.
8. With the operator's display screen shown in the operator's display terminal, press the depth indicator reset pushbutton to reset the hole depth and bit depth indicators to zero.
9. Place hoist brake control in the RELEASE position.
10. On the operator's display terminal with operator's display showing, depress keypad button F5 to turn on PDC. The readout above the F5 key will then read "PDC on."

After the above start-up procedure has been initiated the automatic controls will take over the actual drilling of the hole. Water injection (if so equipped) will be shut off at preset depth. When the total depth of the hole is reached, as preset, the tool string will be automatically hoisted and when the bit approaches the top of the hole, the control will stop the bit, shut off the air and set the hoist brake.

If problems arise in the PDC functions, the system will have to be corrected by a qualified electrician. In most cases, if a malfunction occurs in the automated system, the automated system can be turned off and the drilling completed manually.

PREPARING TO MOVE

Once the hole has been completed and the tool string removed from the hole it is necessary to move the drill to the next hole location to prepare to drill the next hole. Preparing to move the drill consists of proper storage of the tool string, lowering the machine to the ground, and inspection of the machine and travel route prior to propelling.

To prepare the drill to move, proceed as follows:

1. Upon completion of the current hole, hoist the tool string from the hole. If using multiple pipe sections, remove and store all pipe necessary to remove the entire tool string from the hole. Turn off the dust control system and raise the dust curtains.
2. Clamp the stabilizer with the tool wrench to prevent movement of the tool string during propel.



59HR ELECTRIC BLAST HOLE DRILL

---TYPICAL PROPEL CONDITIONS---
ALLOWABLE STEERING SLOPE FOR 59HR

-- WHILE STEERING ON THE SLOPE --

Before propelling read operators manual
The values shown are tilt limits as indicated on the
Leveling/Propel Panelview screen.

MANEUVERING ANY DIRECTION

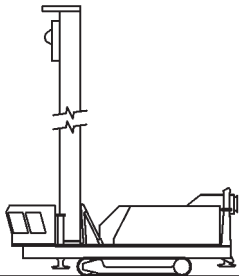

**MAST-UP
HEAD-UP 6.6°**

1-65' PIPE RACKED
1-65' PIPE IN HEAD
W/O CABLE ON REEL

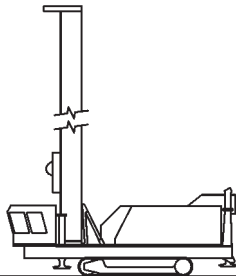

**MAST-UP
HEAD-DOWN 9.4°**

2-65' PIPES RACKED
W/O CABLE ON REEL

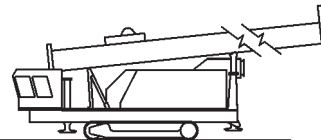

**MAST-DOWN 9.3° LISTING
HEAD-DOWN 21.8° TIPPING**

2-65' PIPES RACKED
WITH CABLE ON REEL

C119070-01 Page 1 Rev. 0

dstb1171

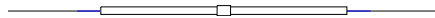



PAO SYNTHETIC HYDRAULIC FLUID

The following bar graph shows recommended viscosity grades for SHC hydraulic oil for various ambient temperatures. For temperatures outside of these ranges, contact the Bucyrus Service Department for recommended oil.

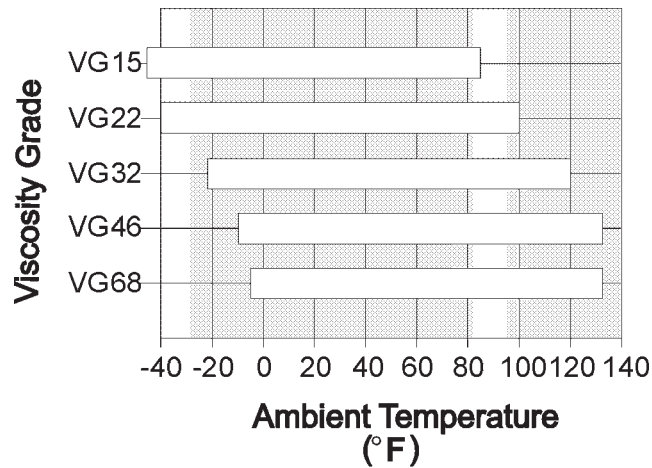

S3_0001

Recommended Viscosity vs. OAT Chart

PARAFFINIC BASE PETROLEUM HYDRAULIC FLUID

Approved oils will typically have Denison HF-O specification certification. In general, the oils will meet the following minimum requirements:

1. Maximum Viscosity = 14,000 SUS (3,000 CST) at the minimum expected ambient temperature (for start-up).



CAUTION: Starting with viscosities greater than 3,000 CST could void warranty.

2. Minimum Viscosity = 65 SUS at the maximum operating temperature of the hydraulic system.
3. Ideal Viscosity = 100 SUS at normal operating temperature of the hydraulic system.
4. Minimum Viscosity Index = 90
5. Neutralization Number = 10 or less for new oil.



LINCOLN AUTOMATIC SYSTEM TROUBLESHOOTING SYSTEMS

The following are normal conditions encountered when setting a new system in operation.

AIR LOCKS

When the system is not primed properly, air is often trapped in the pump, supply line, injectors, or feed lines. Since the air pockets, with their great compressibility, provide a cushion against the normal rapid rise in supply line pressure, they serve to make the cycling of the system sluggish and erratic. In some extreme cases, particularly when the pump is air locked, they may make the system inoperable.

NOTE: If cycling time of a new installation greatly exceeds the cycling time determined from the system planning, it is an indication of an air lock in the system.

Correction:

When the pump fails to prime and pump due to air locks, the vent plug located on or near the pump outlet on all Lincoln models should be opened while the pump is in operation and all of the air allowed to escape. The use of oil as an aid to priming is recommended. Air in the supply lines is expelled by loosening pipe plugs at the end of each line (main supply lines, etc.) and allowing generous quantities of lubricant to escape carrying with it the entrapped air. Air locks in the injectors are corrected, in the case of the SL-1 injectors, by opening the lube fitting and allowing the lubricant and air to escape. Air locks in the feed line can be corrected by loosening the feed line connection at the bearing inlet and allowing lubricant and air to escape as the system is cycled repeatedly. Do not loosen any connections which are under pressure.

DIRTY SUPPLY LINES

This is a preventive maintenance problem and should be thoroughly checked before the system is installed. However, a malfunction of the injectors or the vent valve can usually be traced, by the disassembly of the unit and examination, to foreign material from the supply line inner surfaces preventing proper operation.

Correction:

After the trouble has been encountered, only the disassembly and complete cleaning of the affected units will restore the system to its original state. Preventively, the supply lines should be thoroughly cleaned and blown out before installation.

Bucyrus International, Inc.



**SPECIFICATION FOR
MPG – MULTI-PURPOSE GREASE
SD4711** *(August 18, 2005)*

- b. Base fluid is to be mineral or synthetics which are compatible with mineral base.
- c. Thickener types are to be of the following varieties: Aluminum, Lithium, or Calcium.



LUBRICANT CLEANLINESS

Even the best lubricant is a useless wear preventative if it has become contaminated by careless handling and storage. The lubricant manufacturer packs the lubricant in a tight container to keep it clean. It is the responsibility of the person performing the machine lubrication to be sure that no dirt gets into the lubricant.

Follow these points of good lubrication practice:

- Keep all oil and other lubricants in tightly covered containers.
- Wipe off covers before opening containers.
- Keep funnels, oil cans, grease guns, etc., in a clean place and wipe them off with a clean lint-free cloth before using.
- Wipe off each fitting before attaching the lubricant gun.
- Wipe off oil filler caps or covers and the surrounding area before removing them.

LUBRICATION POINTS AND SERVICE AREAS

The next portion of this manual describes and illustrates the principal points or areas which require lubrication and maintenance. Refer to the topic "Lubricant Benchmarks" in Section 3 of this manual for an explanation of each type of lubricant required for servicing this machine.

The frequency of lubrication given in each chart is intended as a guide only. Under unusual operating conditions, some points may require more frequent lubrication or other special attention. Use good judgment in lubricating the machine. If a bearing is showing signs of trouble, such as overheating or unusual noise, give it immediate attention. Make sure the lubricant was not dirty or of improper viscosity. When the machine is operated for more than one shift each day, all crews must cooperate on checking lubrication. This is to ensure that no lubrication point will be missed, or over-lubricated. It is usually best to do this at the beginning of each shift. Reproducible service schedules are provided for recording service information.

NOTE: Lubrication instructions provided by any vendor for a vendor supplied item have priority over Bucyrus lubrication intervals and procedures.



CAUTION: Do not climb on the machine to perform maintenance procedures. Use a "cherry picker" or "man basket" when inspecting or servicing elevated areas. A slip or fall can result in severe personal injury or death.

CLICK HERE TO **DOWNLOAD** THE COMPLETE MANUAL

- Thank you very much for reading the preview of the manual.
- You can download the complete manual from: www.heydownloads.com by clicking the link below



- Please note: If there is no response to CLICKING the link, please download this PDF first and then click on it.

CLICK HERE TO **DOWNLOAD** THE COMPLETE MANUAL

Section **5****Service Procedures**

Always refer to the safety information in Section 1 of this manual before starting any maintenance procedure on this machine.

Table of Contents

MAINTENANCE SCHEDULES AND REPORTS	5
SAFETY	7
IN-OPERATION MAINTENANCE	7
PRECAUTIONS BEFORE AND DURING MAINTENANCE WORK	8
LOWER WORKS	9
<i>Lower Works Exploded View</i>	9
CRAWLER BELTS	9
ADJUSTMENT	10
LINK REPLACEMENT	11
BELT REPLACEMENT	12
<i>Crawler Belt Replacement</i>	12
LOWER ROLLERS	14
<i>Crawler Frame Lower Load Rollers</i>	14
UPPER ROLLERS	16
<i>Crawler Frame Upper Load Rollers</i>	16
TAKE-UP TUMBLERS	18
DRIVE TUMBLER	20
<i>Drive Tumbler and Planetary Gearbox - Two Versions</i>	20
PLANETARY GEARBOX	21
<i>Planetary Gearbox - Exploded View</i>	23
CRAWLER FRAMES	26
<i>Crawler Frame Removal</i>	26
AXLES	28
<i>Front Equalizer Axle</i>	28
<i>Rear Pivot Axle</i>	29
MAINFRAME	31
BIT VIEWING HATCH	32
MAST A-FRAME	33
LEVELING JACKS	34
MACHINERY HOUSE	38
<i>Compressor Radiator Compartment</i>	39
HOUSE VENTILATION FAN AND FILTER	40
WALKWAYS AND LADDERS	40
OPERATOR'S CAB	41



6. Insert sufficient shims in front of the supports to maintain the adjustment. Several different thicknesses of shims are provided. Be sure that the shims are the same thickness behind each support.
7. Remove the hydraulic jacks.
8. Reinstall the shim guards on the crawler frame.
9. Repeat the procedure for the other crawler belt if necessary.
10. Remove blocking and lower machine.

LINK REPLACEMENT

To replace a link in the crawler belts:

1. Propel the machine to position the defective link in an accessible position near one end of the crawler.
2. Remove the tension from the belt by removing all of the tensioning shims from behind the take-up tumbler supports. Refer to the CRAWLER BELT ADJUSTMENT for details of this procedure.
3. Secure the belt against unwanted movement.
4. Attach a suitable lifting device to the defective link. Part the belt at the defective link by removing the two link pins securing the link to one end of the belt.
5. With the lifting device, lower the end of the crawler belt with the defective link to the ground.
6. Remove the defective link from the belt.
7. Install the replacement link on the end of the belt resting on the ground.
8. Using the lifting device, lift the end of the belt into position to insert the remaining link pins.

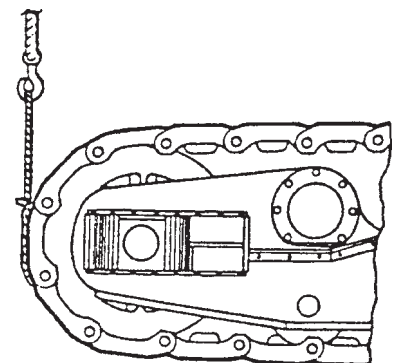

clrp_59r



1. Relieve the crawler belt tension and separate the crawler belt as detailed in the CRAWLER BELT REPLACEMENT topic of this manual. Separation of the crawler belt should take place near the drive tumbler and the links laid back out of the way.
2. Using the machine leveling jacks, raise the machine sufficiently to allow the drive tumbler to clear the lugs on the crawler belt. Block the machine in the raised position.
3. Remove the tumbler retainer bolts and remove the tumbler from the planetary gearbox.

NOTE: The tumbler retainer bolts are metric bolts.

4. Inspect the drive tumbler. Repair or replace if the lugs or rolling surface are worn or damaged.
5. Install the drive tumbler on the planetary gearbox. Torque the bolts to 2,600 Ft-Lbs. (lubed) and 1,100 Ft-Lbs. (lubed) respectively.
6. Remove blocking and lower machine. Verify that all of the rollers and the drive tumbler are resting on the roller path of the belt.
7. Assemble and adjust the tension of the crawler belts as described in CRAWLER BELT ADJUSTMENT.
8. Propel the machine to check the operation of the drive tumbler.

PLANETARY GEARBOX

The planetary gearbox should be checked daily for oil leaks. The oil level should be checked weekly by removing the oil level plug. The gearbox uses approximately 7.9 gallons of lubricant. The oil should be changed after the first 150 hours of operation and then every 1,500 hours of operations. Additionally, after 12 months of operation, the gearbox should be drained and flushed completely prior to refilling with new oil.



CAUTION: Be careful when removing the plugs, especially if the unit is hot. Pressure builds in the gearcase and as the last thread of the plug is removed, the plug may fly off with some force.

Monthly, the external bolts of the gearbox should be randomly inspected for tightness. Bolt torques are shown on figure.

To remove the gearbox from the crawler frame proceed as follows:



MAINFRAME

The 59HR drill mainframe consists basically of two I-beams tied together with bracing and covered on the top surface with deck plates. Inspect the drill mainframe for wear, damage or cracks. *Pay particular attention to the following critical areas.*

- Cross bracing which ties the bottom flanges of the I.-beams together.
- Cross bracing and deck plates which tie the top flanges of the I-beams together.
- Mast lock pin attachment areas.
- Leveling jack attachment areas.
- Areas where the mast A-Frame is pinned to the mainframe.
- Mast hoist cylinder attachment lugs and the immediate area surrounding these lugs on the mainframe.

Cracking, wear or damage to the critical areas listed above require immediate repair. The urgency of repair to other areas of the mainframe plates is dictated by the area in which the repair must be done and the severity of the damage. Minor damage may not require immediate attention but all damage to the mainframe should be repaired at the first available opportunity. Repair to the mainframe is limited to repair welding. If damage is severe or unusual circumstances arise, contact the Bucyrus International Service Department for specific recommendations.

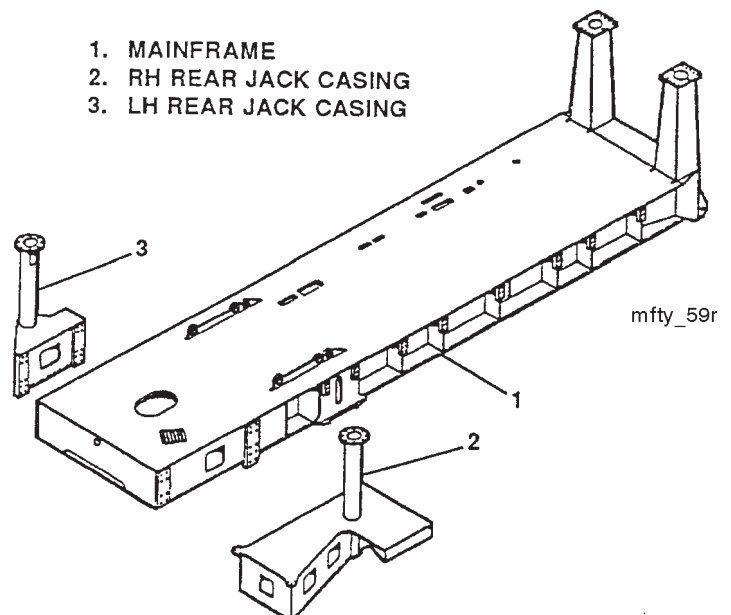



OPERATOR'S CAB

Inspect the operator's cab daily for cracks or structural damage to all side, roof and floor panels. Check the doors and windows for proper operation and correct sealing. Keep the cab clear of all oil, grease or water spills to help prevent slipping.

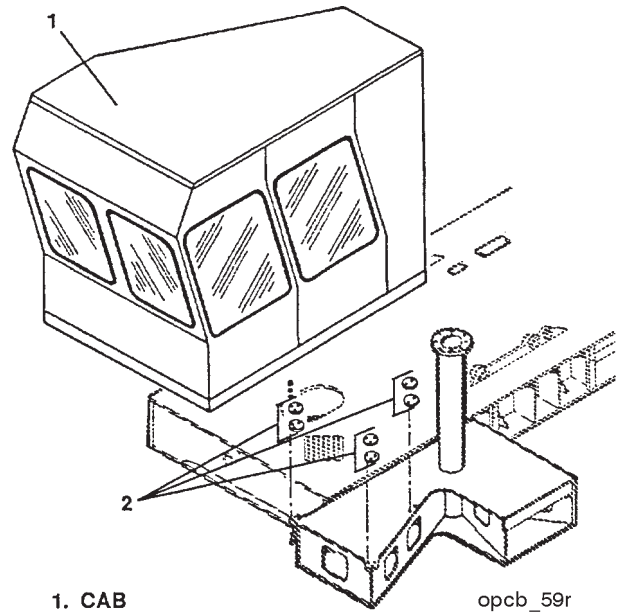

- 1. CAB
- 2. CAB MOUNTING PADS

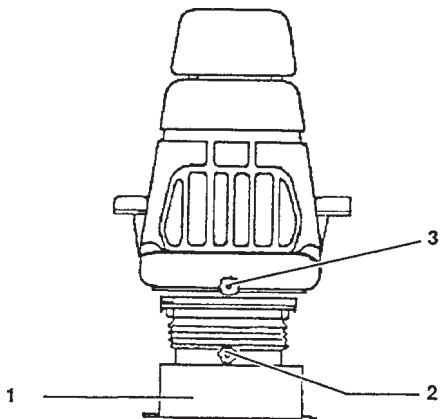

- 1. WEIGHT COMPENSATION
- 2. HORIZONTAL SLIDE ADJUSTMENT
- 3. SEAT SLOPE ADJUSTMENT

OPERATOR'S SEAT

The individual operator may adjust the operator's seat as desired with respect to height, tilt and travel. Periodically lubricate all bearings and pivot points to maintain smooth movement.

OPERATORS CONTROLS

Inspect all of the operator's controls daily for wear or damage. Verify the correct operation of all controls daily. Repair or replace malfunctioning controls immediately. Clean all nameplates and markers and maintain all markers and signs in a legible condition including warning signs.

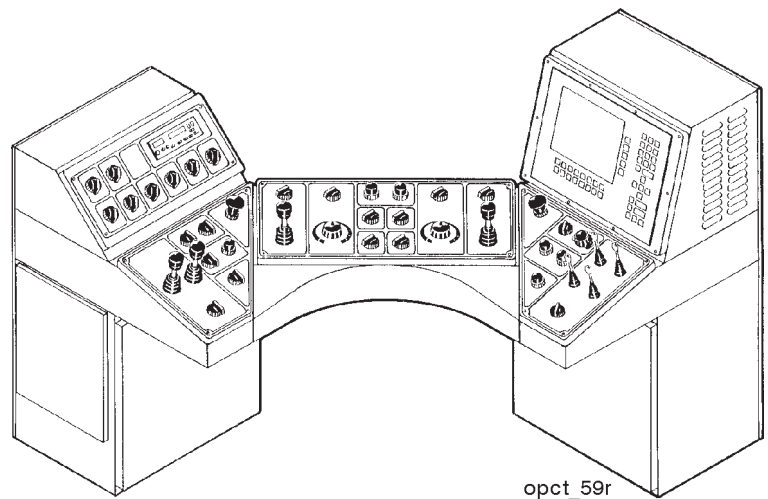



59HR ELECTRIC BLAST HOLE DRILL

- 1. TRAIL CABLE
- 2. #8 600V WIRE
- 3. JUNCTION BOX
- 4. 2/0 8 KV WIRE
- 5. COLLECTOR COVER
- 6. COLLECTOR RING ASSEMBLY
- 7. #6 GROUND WIRE
- 8. REEL SHAFT
- 9. JUNCTION BOX
- 10. 8 KV INSULATORS
- 11. #12 SO WIRE & PLUG
- 12. JUNCTION BOX
- 13. MOTOR STARTER & CONTROL
- 14. ELECTRIC MOTOR
- 15. GROUND LUG
- 16. CONNECTING CABLE
- 17. JUNCTION BOX
- 18. CONTROL VALVE WIRING
- 19. CONTROL VALVE

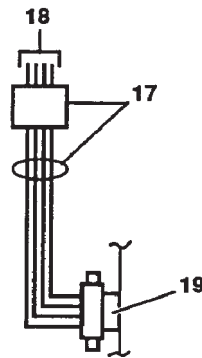
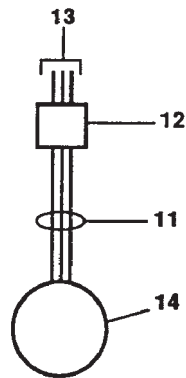
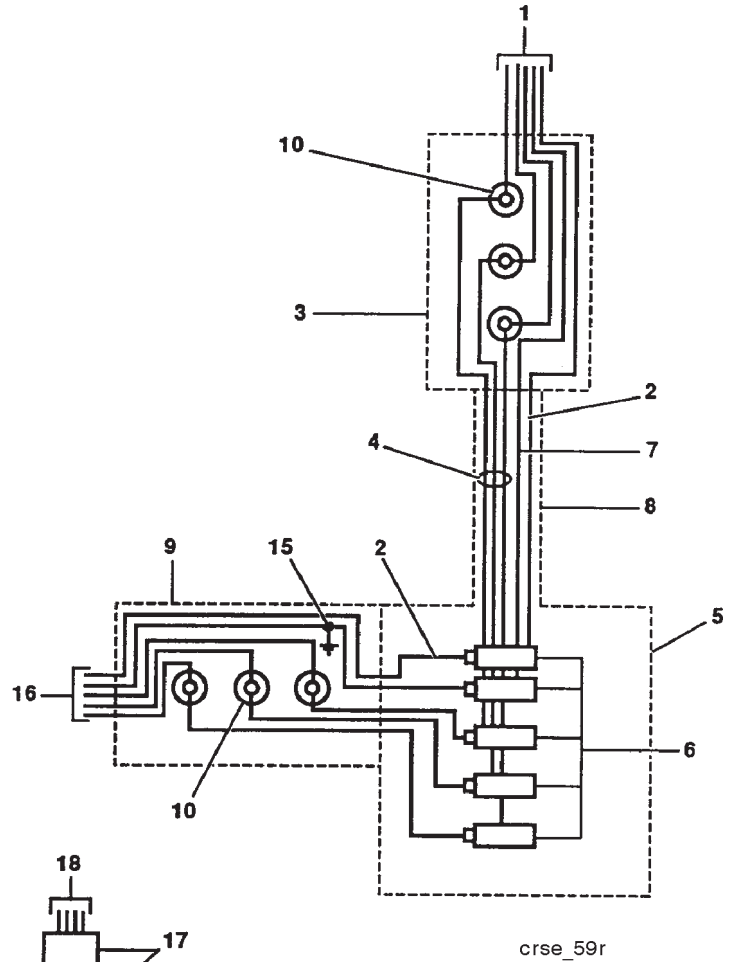

Cable Reel Electrical Schematic



ROTARY MOTOR

Inspection, lubrication and maintenance instructions for the rotary motor are described in the manufacturer's Motor Manual. *To remove the rotary motor proceed as follows:*

1. Lower the rotary drive unit to the bottom of the mast and rest it on the lower stops.



DANGER: HIGH VOLTAGE. OPEN AND TAG THE AUXILIARY POWER AND CONTROL BREAKERS IN THE MACHINERY HOUSE BEFORE ATTEMPTING TO DISCONNECT THE MOTOR LEADS. Failure to comply may result in serious injury or death.

2. Have an electrician identify and disconnect the electrical leads to the rotary motor. Remove the cable from the junction box on the motor.
3. Remove the motor attachment stud nuts and washers.
4. Using a suitable crane and rigging, lift the motor from the rotary gearcase.
5. Repair or replace the motor as necessary.
6. The motor pinion is press fit to the motor shaft. Refer to the topic MOTOR COUPLINGS for instructions regarding replacement or installation of the motor pinion.
7. Prior to installation of the motor clean the mounting surfaces on both the gearcase and the motor
8. Install the rotary motor in reverse order of removal. Torque the attachment stud nuts using turn-of-the-nut method. Tighten nuts snug, and then an additional 1/3 turn.

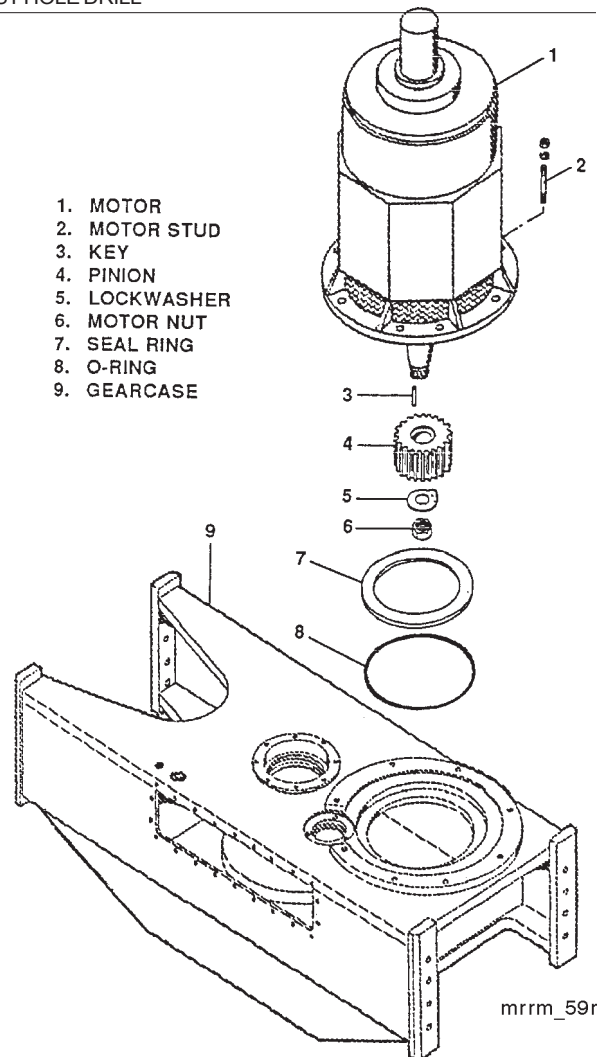

mrrm_59r



PULLDOWN GEARCASE

Inspect the pulldown gearcase every shift for loose or missing hardware. Check the gearcase for lubricant leaks and repair as necessary. Verify the operation of the automatic lube system or manually lubricate all points as necessary. Check the lubricant level in the gearcase and add the proper lubricant to the required level. If water has accumulated in the gearcase, remove the drain plug and completely drain the case. Refill the gearcase to the required level with an approved lubricant.

Repair of the pulldown gearcase is limited to replacement of worn or damaged components. The unit may be repaired in place on the machine or may be removed from the machine and repaired elsewhere. Refer to the topic ROTARY/PULLDOWN GUIDE FRAME for the procedure necessary to remove the assembly from the machine. *To repair the pulldown gearcase proceed as follows:*

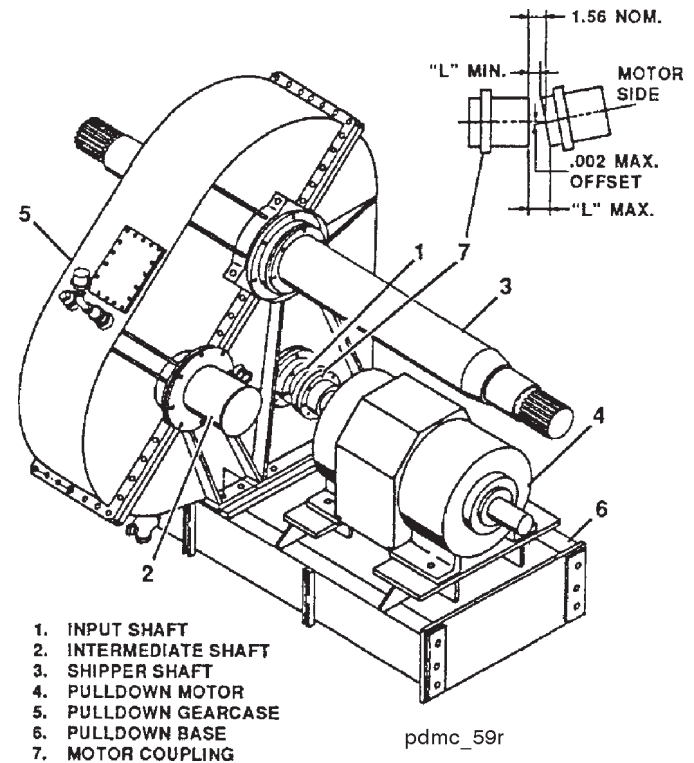

NOTE: For this procedure we will consider the pulldown gearcase has been removed from the machine per Steps 15 and 16 of the topic ROTARY PULLDOWN GUIDE FRAME - REPAIR.



CAUTION: Be sure the rotary pulldown guide frame is secured to the mast by cable or other means, since the rack pinions and upper guide rollers have been removed.

1. Remove the bearing spacer from the ends of the shipper shaft. Use a puller to remove the end bearing from the shaft. The bearings have an interference fit of 0.0018 - 0.0038" to the shaft.
2. Slide the bearing housing from the shaft and separate the inner labyrinth seal from the housing.
3. If not previously done, drain the gearcase.
4. Remove the bearing cover from the gear end of the intermediate shaft. Remove the o-ring from the cover.



4. Remove the bolts attaching the middle pivot bracket to the bracket support. Remove the cover from the pivot bracket and remove the bushing halves.
5. Secure a suitable crane and rigging to the pipe rack. Separate and remove the rack positioning cylinder. With the crane lift the pipe rack from the mast bottom plate. Remove the bushing from the mast bottom plate.
6. Clean and inspect all components. Replace worn or damaged components as necessary.
7. Reinstall in reverse of disassembly, lubricate all lubrication points and check for proper operation.

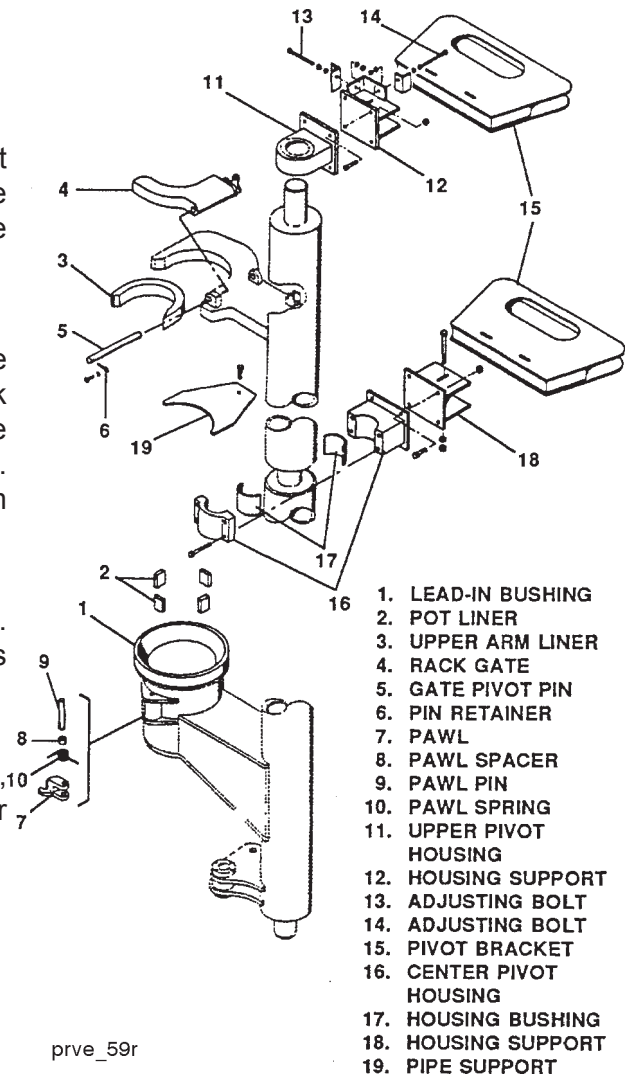

TOOL WRENCHES

The tool wrenches are used to clamp the drill pipe in order to break a pipe joint. The tool wrenches are two specially built hydraulic cylinders operating inside a square casing. A spring loaded pawl engages a pocket in the drill pipe to prevent rotation of the pipe.

Inspect the tool wrenches daily for loose or missing hardware, or any wear or damage. Inspect the wrenches each shift for proper operation. Check each wrench and associated hydraulic lines for oil leaks and repair any leaks found immediately. Verify that the pawls are fully extended and secured with dowel rod. Verify that the wrenches can pivot about the Year pin. Clean any accumulation of cuttings from beneath the wrenches. Verify that the top blocks are in place and intact. Verify that the rear pin bearing blocks are secured firmly to the drill deck and that the piston rod anchor bolts are secure. Lubricate the assembly with an approved lubricant at the recommended intervals.



59HR ELECTRIC BLAST HOLE DRILL

1. Loosen the two handscrews on the strainer cover.
2. Move the cover to the side. The strainer basket will drop out of the housing.
3. Clean the strainer basket and reassemble into the housing.
4. Close the cover and tighten the cover handscrews.

DECK WASHDOWN SYSTEM

When the machine is equipped with a deck washdown system, switch WIS (on the operator's console) will have an additional position designated WASHDOWN. With the switch in the WASHDOWN position, solenoid valve WV on the 4-station manifold will energize and activate the washdown hydraulically operated ball valve to close off water to the mast air pipe and direct the water to the deck washdown hose.



CAUTION Ball valves with hydraulic actuator are hydraulically controlled with a spring return. The spring in the actuator is extremely strong. The screws that secure the spring and cover are not long enough to relieve the spring tension. Before attempting to remove the cover screws, the cover **MUST** be restrained (ie: in a vise). Then open the vise **SLOWLY** until the spring tension is relieved.



PROPEL ENABLE VALVE AND LOW SPEED SELECT CHECK

1. With drill/propel select switch in PROPEL NORMAL, in on-board propel, with a 1500 PSI gauge at test ports 8 and 18, start the pumps and depress the drill/propel ON pushbutton. Record the pressure at test ports 8 and 18. Test port 18 should be the same as pressures noted in step 2 of CONTROL PRESSURE CHECK. Test port 8 reading should be zero (0)
2. With pump still running, first lift one propel joystick out of the DETENT position and then release it. Do the same with the other joystick.

NOTE: There is no need to move joysticks out of NEUTRAL. Just lift the joystick clutch straight up to engage solenoid Propel Active Valve (PAV). Accomplishing step 2 will cause PAV to energize which should cause pressure at test port 18 to go from 600 PSI to 0 and test port 8 should go from 0 to 600 PSI.

3. With a 1500 PSI gauge at test port 9 and the pumps running, rotate Propel Selector Switch to SLOW speed and record pressure.
4. Pressure in step 3 should be within 50 PSI of control pressure check step 2.
5. With Propel Selector in NORMAL, record pressure at test port 9. (Should read zero.)

JACK CYLINDER CHECK IN MANUAL MODE

NOTE: Under no circumstances must either 3-spool valve or relief valve adjustments be allowed to bottom-out. The spool valve is located on the back wall of the machinery house to the left of the hydraulic oil tank and slightly below the top of the tank. The main relief is near the inlet port.

1. With a 7,500 PSI gauge at test port 16 and pumps running, energize auto level in RETRACT mode. With all cylinders fully retracted, adjust 3-spool valve relief to show exactly 3,300 PSI on the gauge.
2. Check all jacks for operation versus manual lever movement (i.e. moving the right front jack control to EXTEND, extends the right front jack. Check both directions with all 4 jacks).

NOTE: Re-check hydraulic oil level and add oil as required.



WARNING: Set flow controls per FLOW CONTROL CHECK before continuing with step 3.



NOTE: An alternate way to accomplish step 3-i is to disconnect hoses at both mast hoist cylinders and then plug hoses with steel ORS plugs. With hoses plugged, start pumps and operate mast hoist in RAISE and LOWER mode to set port reliefs to 200 PSI greater than observed at steps 3-e and 3-h respectively. When reliefs are set, reconnect hoses and check function of mast hoist.

AUXILIARY WINCH

With a 7,500 PSI gauge at test port 16, proceed as follows:

NOTE: If the mast is not mounted, skip to step 4.

1. With the mast mounted and in the rack (fully down), operate the winch with no rope on the drum to check function verses master switch position.
2. Check the ability to smoothly start in the HOIST and LOWER mode.
3. Check drum RPM in the HOIST and LOWER mode and record. Drum speed should be:

10 revolutions in 17 seconds (36 RPM).
4. If mast is not mounted, set port relief so pressure gauge shows 3,000 PSI in the HOIST position when moving the master switch out of NEUTRAL. Moving hoist lever to full LOWER position will show 3,300 PSI on gauge.

NOTE: If mast is mounted, port relief setting may be observed by first disabling WACV electrically and then proceeding per step 4.

49HRIII Blast Hole Drill

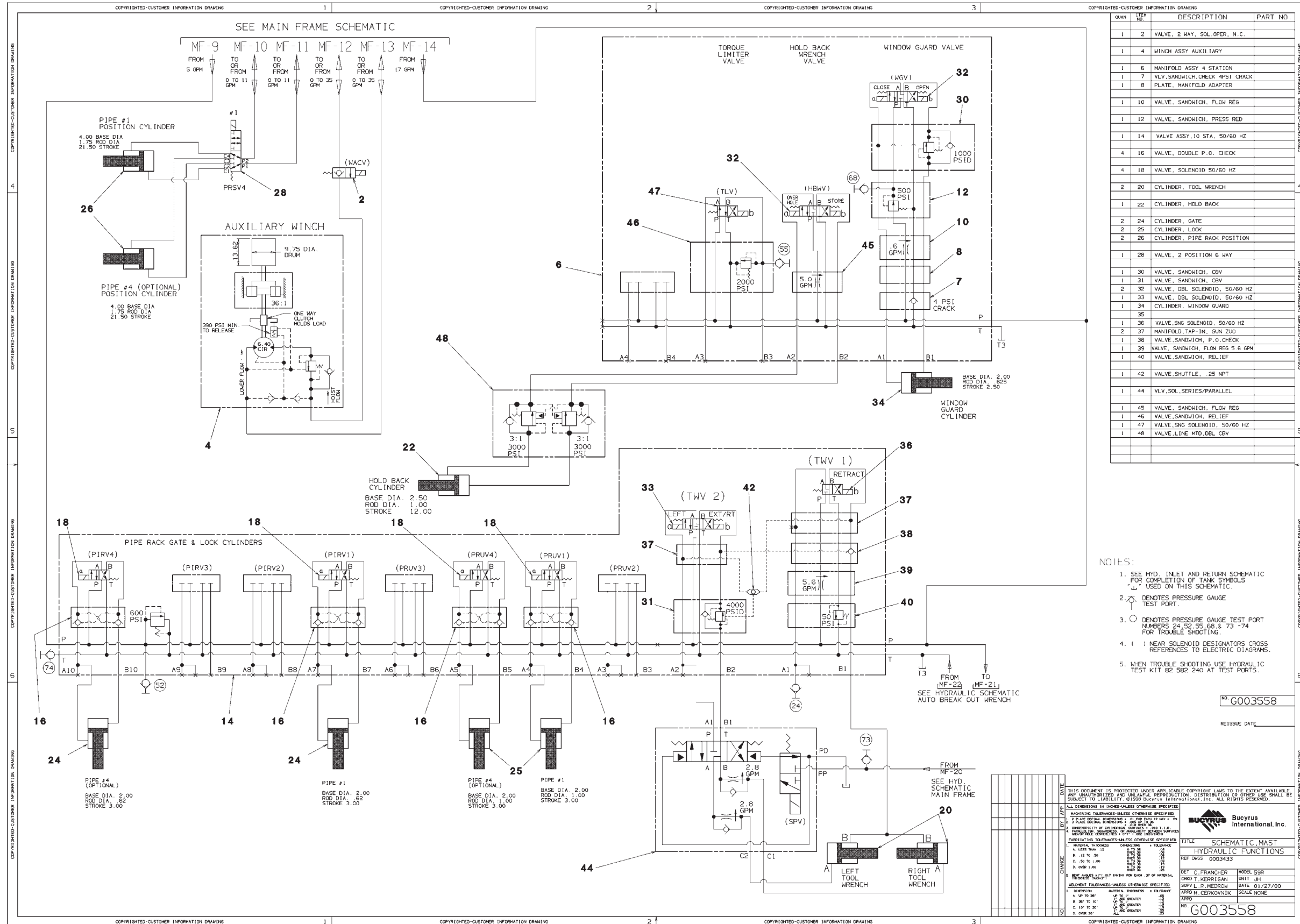



The taper fit between mating parts shall be checked at assembly with Dykem or Blueing to assure a minimum of 80% bearing contact by marking during initial fit-up and comparing to actual fit after assembly.

Motor Shaft Size	ADVANCE (inches per 1.25 in/foot taper)	Estimated Temperature Difference (Centigrade / Fahrenheit)
2.000	0.011 to 0.016	63 / 145
2.500	0.013 to 0.018	54 / 130
3.000	0.015 to 0.020	49 / 120
3.250	0.016 to 0.021	46 / 115
3.625	0.017 to 0.025	42 / 107
4.250	0.019 to 0.027	38 / 100
4.625	0.021 to 0.029	38 / 100
5.000	0.022 to 0.030	37 / 98
5.875	0.027 to 0.037	37 / 98
6.250	0.028 to 0.038	35 / 95
7.000	0.031 to 0.041	35 / 95

chcpgadv

S6_02

Motor Coupling Pre-Heat Advance Requirements Table

MOTOR COUPLING ALIGNMENT

Final alignment of direct-driven units is made by moving or shimming the unit so that misalignment of the unit and drive shafts is within required tolerance from the general arrangement drawing received with your machine. Misalignment can be either offset, angular, or a combination of both. Misalignment can occur in both the vertical and the horizontal plane. Refer to the following illustrations to bring couplings within the maximum acceptable misalignment.

The following method of coupling alignment uses a dial indicator. Readings taken 180 degrees apart will measure the runout in one plane. It is important to rotate both shafts to avoid errors due to surface imperfections of the shafts or couplings.

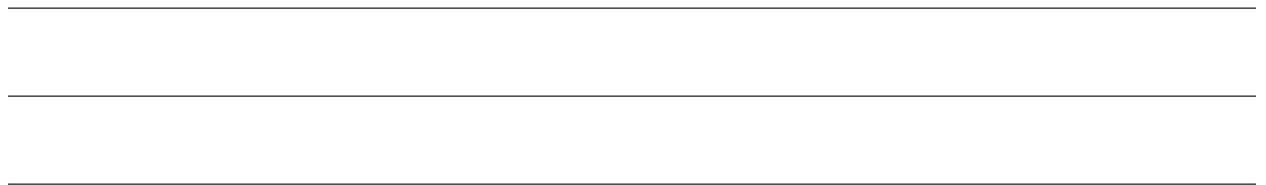

ROTARY SCREW COMPRESSOR

This compressor is an A-C Compressor corp. KS-40-LU. The air end of the screw compressor is an oil flooded, single-stage, twin screw, rotary type. The following illustration, viewed from the bottom inlet end of the compressor, shows how it works. The suction (inlet) port is located on the top, drive shaft (inboard) end of the compressor. The discharge port is located on the bottom (outboard) end.

As the male rotor is turned counterclockwise (by the clockwise rotation of the gear shaft and gears - not shown), it drives the female rotor clockwise. This action causes air to be drawn through the suction port completely filling the uncovered channels or grooves between the spiral (helical) lobes in the male and female rotors. As the rotors continue to turn, the lobes begin to intermesh at the bottom. This intermeshing causes the spiral grooves to become shorter, thus resulting in the compression of the air entrapped in the grooves. Compression continues until the grooves are uncovered by the discharge port.

During the compression process, cool oil is injected into the entrapped air by a gear-type oil pump, direct driven by the outboard end of the male rotor. *The oil is injected for the following reasons:*

1. **COOLING** - The oil removes the heat of compression to maintain discharge air temperatures below 200°F.
2. **SEALING** - The oil seals the internal clearances between the rotor, cylinder, and discharge end casing to prevent loss of air volume back to the inlet.
3. **LUBRICATION** - The oil lubricates the rotors, bearings, gears, and mechanical shaft seal.

SCREW COMPRESSOR FUNCTION

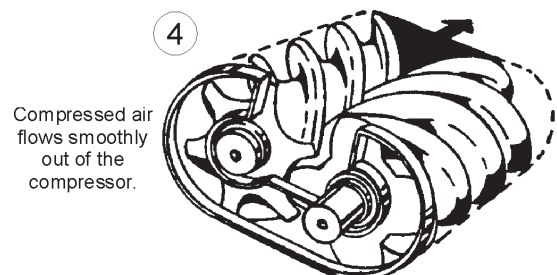
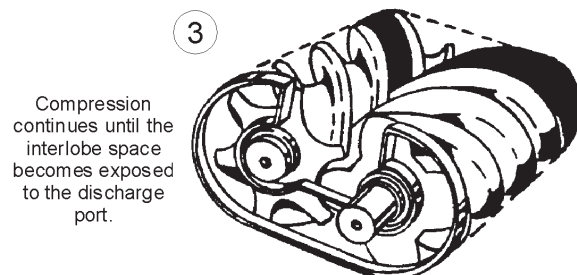
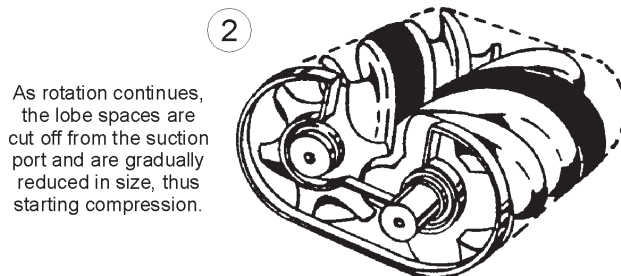
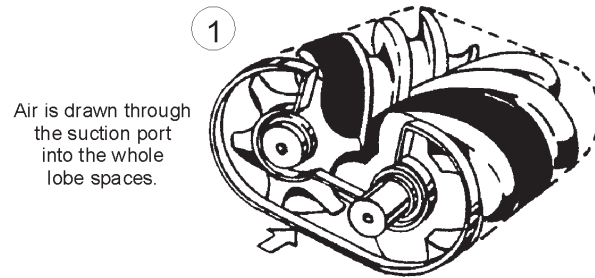

59RS7_03



HOURMETER

A continuous reading (non-reset type) hourmeter is installed on the instrument panel and displays the accumulated operating time of the compressor. It provides a convenient means for scheduling the oil supply change-outs (every 1000 hours).

SAFETY RELIEF VALVE

A pressure safety relief valve located on the side of the receiver and set to relieve the pressure at 85 PSIG. Periodic checks should be made to insure its proper operation.



CAUTION: NEVER OPERATE THE UNIT WITHOUT A PROPER SAFETY VALVE SETTING.

SOLENOID BLOWDOWN VALVE

A solenoid valve installed on the receiver outlet and wired to automatically open and blowdown the receiver, piping and compressor air end when the compressor is stopped. The blowdown time is approximately one minute to reduce the pressure down to 0 PSIG.

NOTE: Too rapid a blowdown would cause oil foaming and excessive oil carry-over past the oil separator.

COMPRESSOR OIL COOLER

The oil cooler is a radiator type which utilizes a pusher-type fan driven by a separate electric motor. Do not obstruct air flow to and from the cooler. Keep both faces of the oil cooler core clean for efficient cooling of the compressor oil. Oil cooler malfunction may be diagnosed by a higher than normal oil injection temperature. This oil temperature normally should not exceed 150°F when the ambient air temperature is less than 100°F.



CAUTION: DO NOT INSTALL A THERMOSTATIC CUT-OUT ON THE RADIATOR FAN MOTOR. This causes thermal cycling of the radiator core which could result in cracks and subsequent oil leakage.

COMPRESSOR OIL SEPARATOR

The oil separator is located in the inside, upper half of the receiver and provides the final removal of oil from the air stream. Oil impinging on the outside of the separator drains directly back into the receiver reservoir. The finer oil droplets are coalesced and collected on the inner wall where the liquid oil drains to the bottom of the separator. A scavenging tube continuously draws off this oil from the bottom and returns it to the compressor inlet through a Y-type strainer and orifice/sight flow indicator.

NOTE: A continuous flow of oil should be visible in the sight glass while running loaded.

Excessive oil carryover to the piping downstream from the receiver may be caused by a faulty oil separator, foaming oil, or an oil scavenging (return) line malfunction. Inspect the oil separator for failure only after it has been determined that the oil is not foaming and the oil return line is not malfunctioning. Check the sight glass in the scavenging line while the compressor is running. If little or no oil is visible, shut down the compressor. Disconnect the line at the sight glass inlet and clean the orifice using a wire or pin. Remove and clean the strainer basket upstream of the sight glass. Before reconnecting the sight glass, blow through the scavenging line into the receiver to make sure that the line is not plugged with solids. Re-connect the sight glass and restart the compressor. If oil flow is still not visible, remove and replace separator as described below.

Oil carryover malfunctions of the oil separator are usually due to using the element too long, heavy dirt or varnish deposits which are the result of inadequate air filter service, using improper oil, or using the oil for too long for existing conditions. Heavy deposits of dirt or varnish build-up on the element will cause it to rupture or collapse. The oil separator should be changed when the separator maintenance indicator shows a red flag in its window while running loaded. This will occur when the air pressure differential across the separator is approximately 10 PSI.



AIR CONDITIONER

DESCRIPTION

SIGMA MPV9 climate control units are heavy duty systems designed to be roof mounted on the cabs of industrial and mining equipment. These units will provide superior performance in a variety of climate conditions and under the most harsh environment.

EVAPORATOR

Air is drawn from beneath the unit, passes over the heat exchanger coil and the heating elements into a double inlet wheel fan deck. It is then discharged through the base of the unit into the conditioned space below. Facility is also available to have supply and return air out the front face of the evaporator unit. Refrigerant flow is metered by an externally equalized TX valve, and is cut off by a liquid line solenoid valve. Heat exchange coil is large, with heavy gauge tubing and coarse fin pitch to reduce clogging. Fan motor is single shaft and of totally enclosed, fan cooled motor construction. Drain pan is large and of "V" design for ease of cleaning and to facilitate draining.

All pressure controls within the evaporator unit are fully sealed, preset and o-ring connected.

CONDENSER

The compressor is a heavy duty, fully sealed scroll device. The assembly is mounted to heavy flexible mounts to reduce noise transmission to the structure and provide some damping of shock. Connections are either soldered, o-ring or rotalock. A large filter drier is mounted in the liquid line to filter and remove moisture from the refrigerant. Isolation valves are installed on either side to enable refrigerant to be "pumped down" and thus enabling core to be replaced without total loss of refrigerant. Condenser fan is single speed.



59HR ELECTRIC BLAST HOLE DRILL

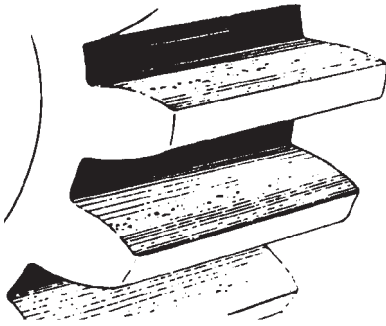

Incipient Pitting. Repeated stresses on the high or hard spots of gear teeth cause local fatigue failure of the metal. Small pieces or particales of metal break out at slightly below the pitch line, leaving small craters or pits. After the high spots have broken out, further pitting may cease and normal wear may eventually polish out the pits.

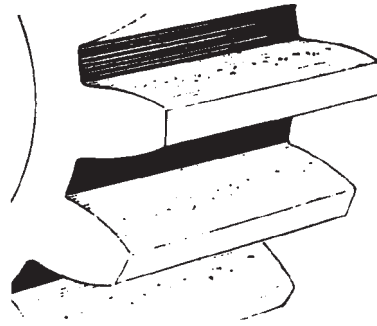

Destructive Pitting. Rough surfaces may have many high spots and may pit so badly that too much of the load-carrying surface is rendered ineffective. When this occurs, the increased loading of the remaining surface causes further pitting until the working areas are destroyed.

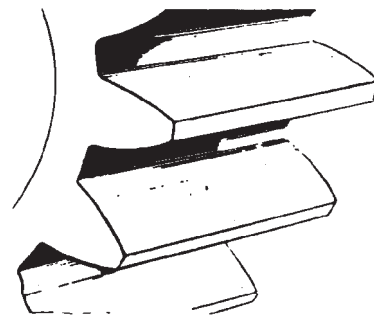

Abrasion. When foreign material of an abrasive nature enters between the meshing teeth, the resulting lapping or grinding action may either polish the surfaces or scratch them. In either case, this is abnormal wear.

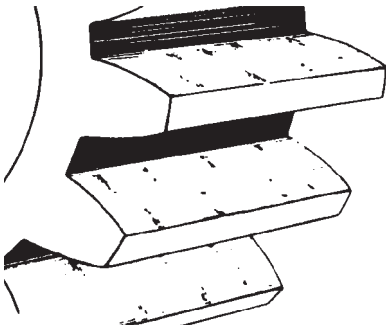

Scratching. When sharp projections on the surfaces of gear teeth pierce the oil film, they gouge or score the surface of the teeth. Rough finish, pitting surfaces, or misalignment may be the cause.

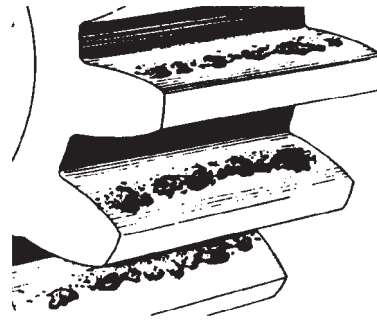

Spalling. Abnormal loading of tooth surface may overstress the subsurface metal until large chips or flakes break away from the teeth.

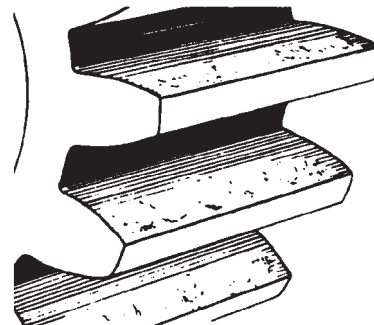

DRIVING PINION. Mild Galling. When full fluid films fail, the first signs of wear occur above the pitch lines of the teeth. The teeth then usually show evidence of a yielding and sliding of the surface and subsurface metal. This yielding then progresses toward the tips of the driving teeth and below the pitch line of the driven teeth.

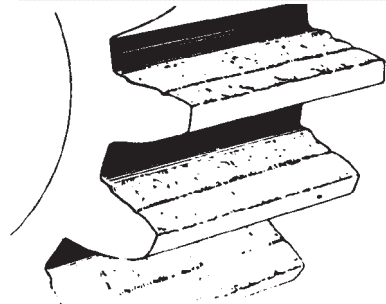

DRIVING PINION. Advanced Galling. Consistent failure of the lubricating film may cause not only localized yielding and displacement of the metal, but also a pressure-welding or seizure between the engaged surfaces when such welding occurs, chips and scales of metal tear from the teeth, and the working surfaces become roughened. Scoring, abrasion and excessive wear follow.

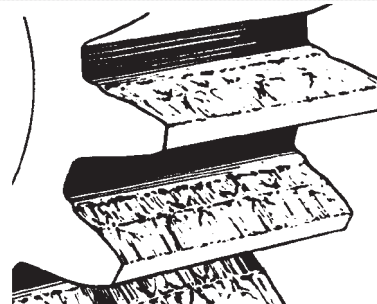

DRIVING PINION. Severe Galling. On a driving gear (pinion) the direction of the slide is always away from the pitch line. Thus where simple galling occurs, the plastic flow of metal tends eventually to create a hollow or groove across the face of each driving tooth and a ridge along the top tooth edge and near the tooth root.

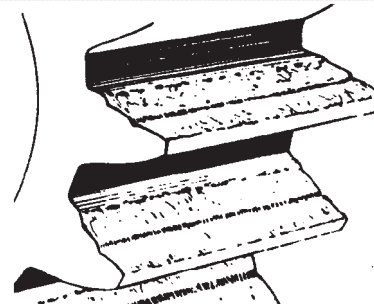

DRIVEN GEAR. Severe Galling. The direction of slide on the teeth of a driven gear is always toward the pitch line. Thus, where simple galling occurs, the movement of metal is always toward the pitch line. Eventually this plastic flow of metal creates a hump or ridge across each tooth.

gearinsp

Gear Tooth Surface Failures



WELDING AND CUTTING EQUIPMENT

The welding and cutting equipment needed for general repair welding is listed below.

WELDING MACHINES, Arc - 600 ampere (for Welding and Air Arcing)
 OXY ACETYLENE TORCHES with Gauges - 150' Long Hoses
 HEATING TORCHES, Butane (for Boom Welding)
 ARC AIR ATTACHMENTS (for use with 600 Ampere Welding Machines)
 WELD RODS - E7018, E8018, E11018 - 1/8", 5/32", 3/16", 1/4"
 CO₂ - Welding Grade - 45°F Max. Dew Point
 OXYGEN - Cutting, and Heating
 ACETYLENE
 WELD FLUX CHIPPERS - Pneumatic with Chisels and Spare Parts
 BLOWERS, Ventilating (for Compartment Welding,)
 GRINDERS, Wheel - Air Powered w/Wheels
 TARPAULINS - Fireproof (for Boom Welding Shelters)
 ASBESTOS GLOVES
 CUTTING GOGGLES, Dark
 SOAPSTONE MARKERS
 ANTI-SPATTER COMPOUND
 TEMPILSTIKS - 200° and 400°

STRESS RELIEVING & TEMPERATURE MEASURING EQUIPMENT

The equipment recommended for stress relieving, after repair welding, is listed below.

TEMPERATURE MEASURING EQUIPMENT
 SPEEDOMAX, "W" Multipoint, Potentiometer Recorder
 POWER REQUIREMENT - 120 Volts, 60 or 50 Hz.
 RANGE - 0 to 1500°F
 CALIBRATION - Chromel-Alumel Thermocouple Wire
 ACCURACY RATING - 0.3% of Electrical Span
 CHART SPEED - 2" per Hour
 THERMOCOUPLE SELECTION - Six (6) Points
 FLUORESCENT LIGHTING
 MANUFACTURER - Leeds & Northrup Company
 THERMOCOUPLE EXTENSION WIRE

CLICK HERE TO **DOWNLOAD** THE COMPLETE MANUAL

- Thank you very much for reading the preview of the manual.
- You can download the complete manual from: www.heydownloads.com by clicking the link below



- Please note: If there is no response to CLICKING the link, please download this PDF first and then click on it.

CLICK HERE TO **DOWNLOAD** THE COMPLETE MANUAL