

Maintenance manual

R60-55/60/70/80

CLICK HERE TO **DOWNLOAD** THE COMPLETE MANUAL

- Thank you very much for reading the preview of the manual.
- You can download the complete manual from: www.heydownloads.com by clicking the link below



- Please note: If there is no response to CLICKING the link, please download this PDF first and then click on it.

CLICK HERE TO **DOWNLOAD** THE COMPLETE MANUAL

About the documentation

Documentation sections

The documentation comprises the following sections:

Operator's manual

Instruktionsbokone supplied with the machine in the cab.

Documentation kit

Maintenance manual and parts catalogue with machine card are supplied to the machine as a separate documentation kit.

Supplementary documentation

Supplementary documentation can be ordered for the machine.:

- Workshop manual including supplier documentation for engine, transmission and drive axle.
- Master catalogue, a general spare parts catalogue covering all alternatives and options for the machine type.

Ordering documentation

Extra issues and supplementary documentation can be ordered from STILL SERVICE.

NOTE

Always indicate publication number when ordering if possible.

Fire and explosion risks

Examples of explosion-prone substances are oils, petrol, diesel fuel, organic solvents (lacquer, plastic, cleaning agents), rustproofing agents, welding gas, gas for heating (acetylene), high concentration of dust particles of combustible materials. Rubber tyres are highly flammable and cause fires that spread explosively.

Risks

Examples of causes of ignition are welding, cutting, smoking, sparks from grinding machines, heat generation in rags drenched with oil or paint (linseed oil) and oxygen. Oxygen cylinders, lines and valves should be kept free from oil and grease.

Fumes from petrol, for example, are heavier than air and can thus "run down" a sloping grade, or down into a grease pit, where welding flames, grinding sparks or cigarette glow can cause an explosion. Evaporated gasoline has a very powerful explosive force.

Special cases

When changing oil in the hydraulic system, keep in mind that the oil may be hot and can cause burn injuries.

Welding on or near the machine. If diesel or other oils have leaked out and have been absorbed by rags, absorbing agent, paper or other porous material, glowing welding sparks can cause ignition and an explosive spread of fire.

When a battery is being charged, the battery electrolyte water is divided into oxygen and hydrogen gas. This mixture is very explosive. The risk of explosion is especially high when a booster battery or a rapid-charge unit is used, as they increase the risk of sparks.

The machines nowadays contain a lot of electronic equipment. During welding work, the control units must be disconnected and current turned off using the battery connectors. Otherwise, strong welding currents can short-circuit the electronics, destroy expensive equipment, and may also cause an explosion or fire.

Welding work must never be carried out on painted surfaces (remove paint by blasting at least 10 cm around the welding or cutting point.) Use gloves, breathing protection and protective safety glasses. Also, welding work must never take place near plastic or rubber materials without first protecting them from the heat. Paints, plastics and rubber generate various substances when heated that may be hazardous to health. Be careful with machines that have been exposed to intense heat or a fire.

Preventive maintenance

Preventive maintenance, general

It is of utmost importance that preventive maintenance is performed according to recommended intervals.

Preventive maintenance shall be performed by STILL, or by service organization authorized by STILL.



WARNING

The warranty is not valid if service intervals are not followed.

Preventive maintenance shall be performed according to prescribed interval and extent.

Use spare parts, oils and fluids approved by STILL.

Preventive maintenance, work instruction

- 1 For a new machine, it is very important to check-tighten the wheel nuts during the first week that the machine is used, this to ensure that the wheel nuts are run in completely. This shall be performed at an interval of 4–5 operating hours (up to approx. 40–50 operating hours).
- 2 For new machine, checks shall be performed after 50h operating time, *50h check, instructions* page 7.
Note completed 50h check in the service log, see *Check and service log* page 4.
- 3 Service at regular intervals shall be performed according to service schedule, see *Service schedule, instructions* page 9. The service schedule shall be followed to ensure the machine's high operating reliability.
Note completed service in the service log, see *Check and service log* page 4.

Object, action	Service			Comments	Reference
	250h, 750h, 1250h, etc.	500h, 1500h, 2500h etc.	1000h, 2000h, 3000h etc.		
Carbon brushes	C/R	C/R	C/R		<i>Carbon brushes, check page 67</i> <i>Carbon brushes, changing page 67</i>
Collector	C	C	C		<i>Collector, check page 67</i>
Accumulator		C	C	Check precharge pressure.	<i>Accumulator, check page 66.</i>
Hydraulic oil			C / R	<p>Check with oil sample.</p> <ul style="list-style-type: none"> If oil sample OK after 2000h, run another 1000h and take new oil sample. If oil sample OK after 3000h, run another 1000h and change oil. <p>Note: Max. 4000h change interval.</p> <p>Additive: Lubrizol should be added when changing hydraulic oil. Concentration 3%.</p>	<i>Hydraulic oil, check page 72.</i> <i>Hydraulic oil, changing page 72.</i>
11 Common electrical					
Fuses	C	C	C	Check that fuses are intact. Change if needed.	
Batteries	C	C	C	<p>Clean if necessary.</p> <p>Grease terminals with vaseline at 250 h service.</p> <p>Check electrolyte level.</p> <p>Change cables and connections as needed.</p>	<i>Battery, checking page 74.</i> See section 11 Common electrical, group 11.3.1 Battery, inspection.
Contact plate	C	C	C		<i>Contact plate, checking page 75</i>

3.3 Drive axle

Drive axle, check

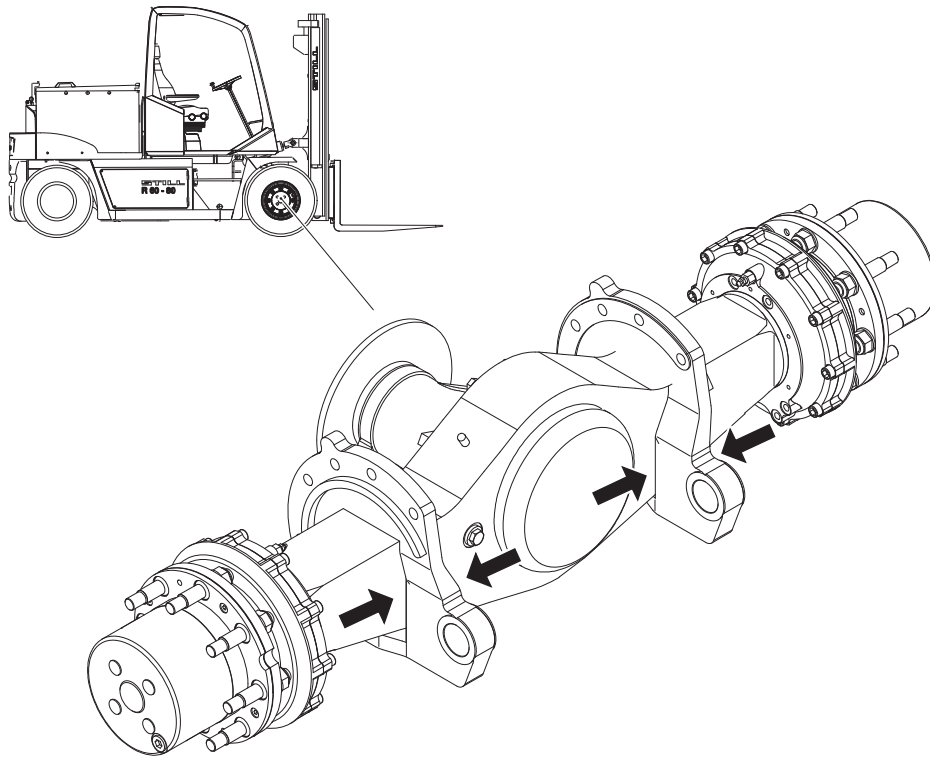

003439

Make a visual check of the drive axle welding joints at the mountings.

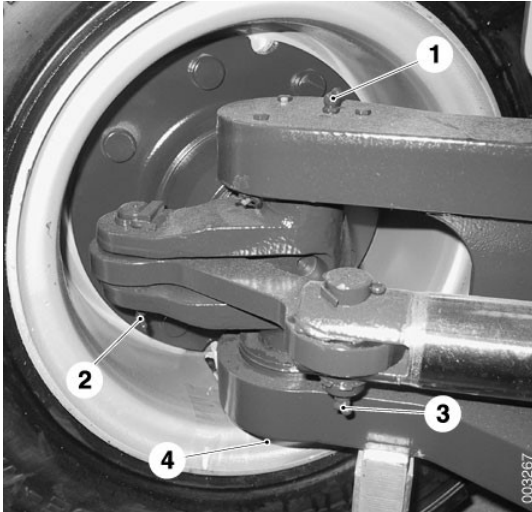

1. Lubrication point, upper spindle joint bearing
2. Lubrication point, outer spindle joint bearing
3. Lubrication point, inner spindle joint bearing
4. Lubrication point, lower spindle joint bearing

- 3 Grease the steering spindle bearing assemblies (upper and lower) using universal grease EP2 on both sides.
If necessary, turn the wheels for better access.
- 4 Remove the blocks.

Tyre and rim system, installing (drive axle)

Read the safety instructions before working with the tyre and rim system, see *Tyres and rims, safety* page 35.

- 1 Lift the inner wheel into place with the lifting equipment.
- 2 Fit any inner spacer ring. The spacer ring is installed differently depending on tyre dimension and make.



002284



002282

- 3 Lift the outer wheel into place with the lifting equipment.

Mast mounting, check

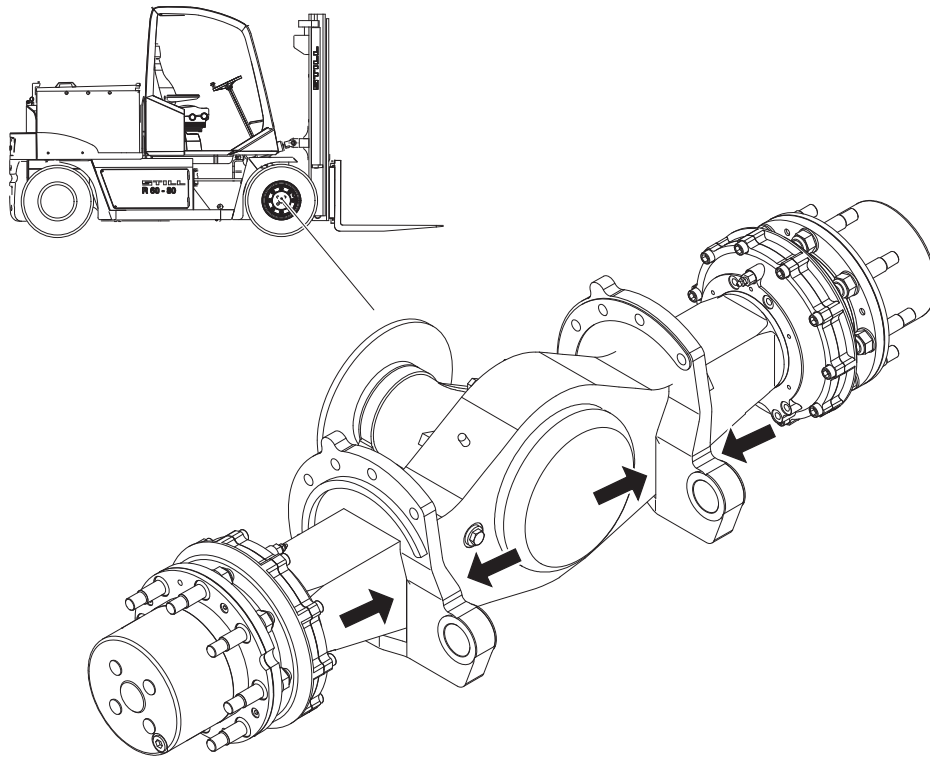

003439

Check visually that the mounting points and welding joints are intact.

See also *Mast mounting, check* page 64.

Mast member, lubrication

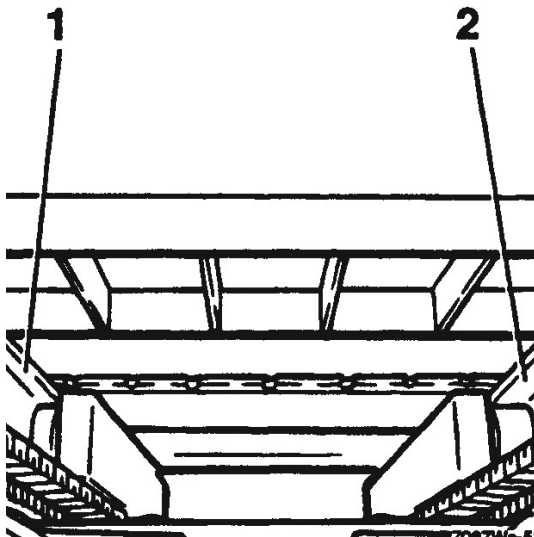

1. Clean the slide rails from dirt and lubrication oil.
2. Grease the outer, intermediate and inner slide rails with high pressure grease, S, to reduce wear.

NOTE

Spray an even layer high pressure grease S on the slide rails. Hold the spray can at a distance of approx. 15 - 20 cm from the slide rails when applying the high pressure grease. Wait for 15 minutes after applying before using the mast beam.

9.10.3 Cab substructure

Cab mounting, check

Check that the welding joints at the cab attachment points are intact and free from visible cracks.

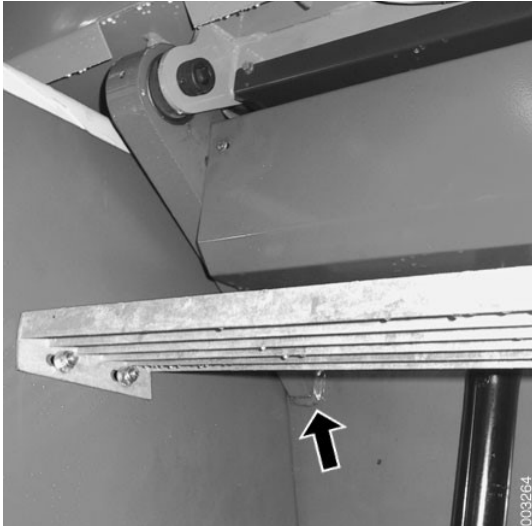

Cab locks, lubrication

- 1 Machine in service position.
- 2 Tip the cab.
- 3 Grease the cab locks using universal grease EP2.

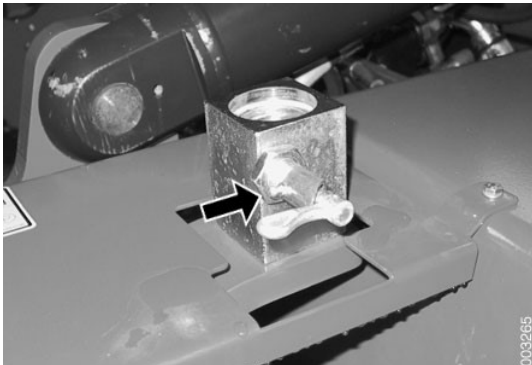

9.10.4 Cab tipping

Cab tipping, check

- 1 Machine in service position.
- 2 Tilt the mast forwards.
- 3 Loosen both cab locks.

NOTE

Remove loose objects in the cab and close the cab doors.

- 4 Tip the cab.

- 5 Clean the area around the filler cap.
- 6 Remove the filler cap.
- 7 Fill new hydraulic oil until the oil level is between MAX and MIN on the dipstick.
- 8 Fit the filler cap.

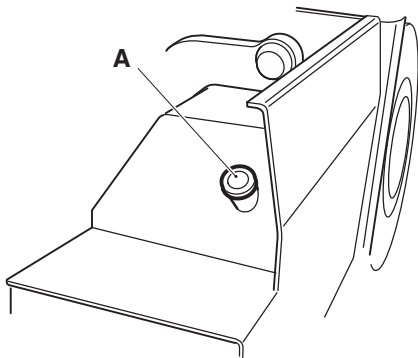
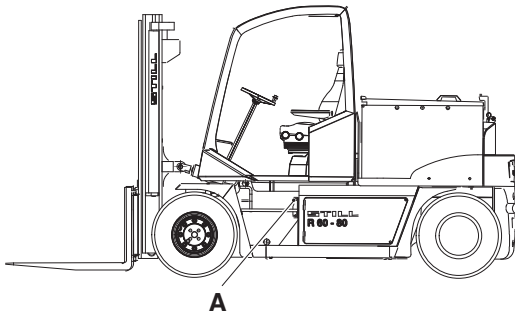

00841

- 5 If there are no error codes, or the problem remains, then read the technical description for the function concerned.

Within the technical description is information on which components are involved in the function and how these components work together. In some cases there is information on which conditions apply in order that the function can be activated.

Troubleshooting with an error code, example

Error codes are strong indications of failures that the control and monitoring system has detected. Many error codes are connected to electrical faults, but there are also error codes that interpret connections between one or more signals that indicate a non-electrical fault. It is important not to draw too hasty conclusions from an error code.

- 1 Read out error code from the display.

Error code	Description	Limit	Recommended action
AL66	<p>Battery malfunction</p> <p>The battery has too high charging level. Max. current is reduced to 50 % to not damage the battery.</p>	Reduced speed	Charge the battery. If operating time has dropped significantly, contact STILL Service or your battery supplier for consultation.

- 2 Follow the instructions in the field Recommended Action.
- 3 Use diagnostic menus and circuit diagrams to determine if the input signal is correct, see section *E Diagrams*. 
- 4 Use the function group to locate more information if necessary (in this case not stated but can be traced to group *4 Brakes*).

Under the sections *1 Engine* to *11 Common electrical (Technical description)* are descriptions of functions (and to some extent also components, more detailed component descriptions and component location in *Workshop manual R60-55/60/70/80*).

Under the sections *1 Engine* to *11 Common electrical (Technical description)* are signal descriptions for most of the functions. The signal description explains how different signals work together in one function. The signal description also contains information on how each signal can be controlled.

Under section *C Preventive maintenance* and in *Workshop manual R60-55/60/70/80* are work instructions for how parts are replaced, checked or adjusted.

- 5 If possible eliminate component fault by testing the component individually.

1.4.3 Carbon brush holder

Carbon brush holder, description

See section *C Preventive maintenance* chapter *Drive motor and Pump motor*.

1.4.4 Carbon brushes

Carbon brushes, description

The length of the carbon brushes should be at least 14 mm.

See also section *C Preventive maintenance*, chapter *Drive motor and Pump motor*.

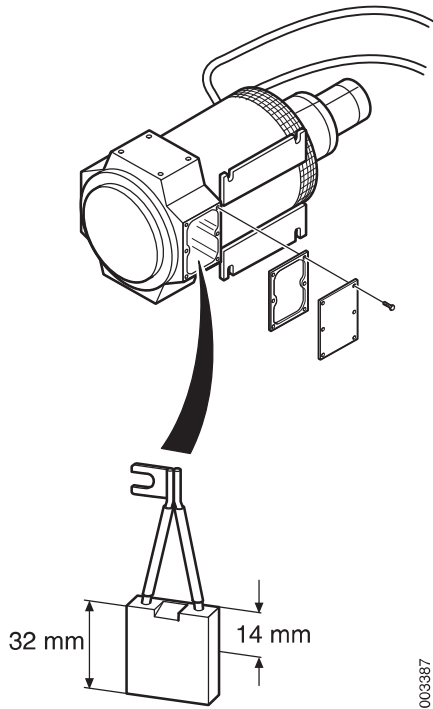

1.4.5 Flange

Flange, description

The flange is located between the shaft on the drive motor and the propeller shaft. It is mounted on the shaft with a key and bolt.

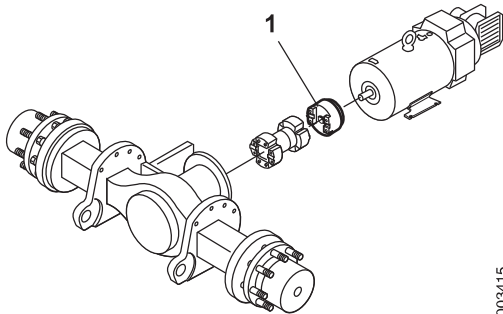

1. Flange

2 Transmission

2.1 Controls and instruments

2.1.6 Travel direction selector

Travel direction selector, description

This section describes the functions of the travel direction selector.

There is a travel direction selector:

- Travel direction selector

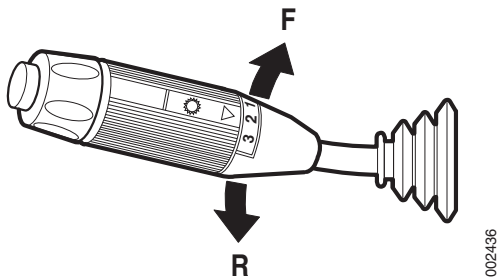

Travel direction selector

Travel direction

Travel direction is selected with the travel direction selector.

Selecting direction of travel:

- F – Forward
- N – Neutral
- R – Reverse (acoustic warning signal )

4 Brakes

Brakes, safety



WARNING

Hot, pressurised hydraulic oil can cause burn injuries, cuts and sight damage.

When working on the brake system, the pressure in the accumulator must be drained. Drain the accumulator by turning off the machine and pressing repeatedly on the brake pedal until the accumulator is empty.



WARNING

Gravel around the pedal and brake valve can obstruct or prevent braking.

Clean away gravel from around the pedal and brake valve.



WARNING

Water, damp or corrosive substances around the pedal and brake valve can cause rust that causes the brake valve to bind, which obstructs or prevents braking.

Keep it dry around the pedal and brake valve.

4.3.5 Brake valve

Brake valve, description

The brake valve controls the hydraulic pressure to the brakes and the pressurising of the accumulator. The brake valve is fitted under the cab floor, a lever transfers the pedal force to the valve.

For more information, see *Workshop manual R60-55/60/70/80*.

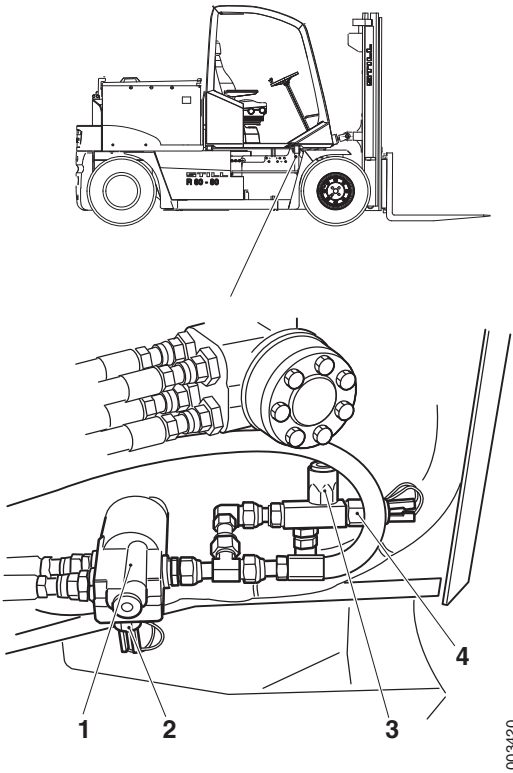

1. Brake valve
2. Break contact low brake pressure
3. Make-contact output reduction
4. Make-contact brake light

4.6 Speed retardation system

Speed retardation system, description

The electric motor brake (recharging) works in parallel with the machine's servo brake system and is controlled by the drive regulator.

How heavily the machine is braked with the motor depends on which braking method is used.

During electric motor braking, the machine's kinetic energy will be charged back to the battery. The drive motor will now function as an alternator that charges the battery via the drive regulator.

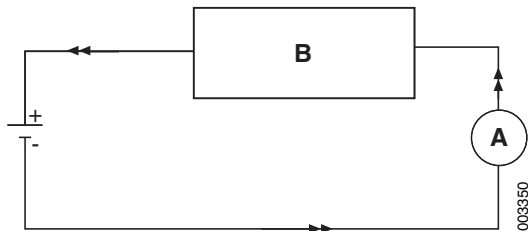

- A. Drive motor, functions here as alternator
- B. Drive regulator

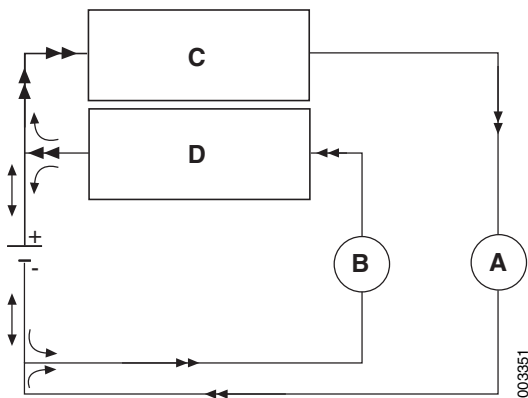

- A. Pump motor
- B. Drive motor, functions here as alternator
- C. Pump regulator
- D. Drive regulator

During motor braking when the pump regulator is used at the same time (e.g., the machine is moving and accumulator is charging) the kinetic energy that is recycled from the drive regulator will be used primarily for the pump regulator and then for recharging the battery.

Advantages of motor brake:

- Almost rpm-independent braking torque
- Reduced armature current and subsequently reduced warming of motor
- The energy is re-supplied to the batteries. This gives longer operating time per charging and, most of all, extends the batteries' service life.

5.2.8 Wheel hub

Wheel hub, description

See *Workshop manual R60-55/60/70/80*.

5.2.13 Pressure reducing valve

Pressure reducing valve, description

See section *10 Common hydraulics*, group *10.5.2 Main valve*.

5.2.14 Pressure limiting valve

Pressure limiting valve, description

See section *10 Common hydraulics*, group *10.5.2 Main valve*.

5.2.17 Pipes and hoses

Pipes and hoses, description

See *Workshop manual R60-55/60/70/80*.

- Double-check that the rim components are mounted correctly and that the rim nuts are tightened to the correct torque.
- Do not inflate the tyre before all parts are in place. Check again that all parts are in place when the tyre pressure has reached 0.3 bar (30 kPa).
- When inflating, use a self-locking air-chuck and move to the side. If the tyre has been completely deflated, the rim must be dismantled and checked for damage.
- Poorly inflated tyres reduce stability and consequently the capacity of the truck. Therefore, always keep the tyre pressure at the prescribed level. Check the pressure daily. Do not have too high pressure in the tyres.
- Check the tyres daily. Remove stuck objects such as crushed glass, pieces of wood, metal filings, etc. Check for uneven and quick wear, this is often caused by uneven brake action, for example. Make sure that such defects are repaired immediately.

Installing

- Make sure that the mounting surfaces on hub and wheel are clean from paint and grease.
- Tighten the bolts crosswise to the correct torque.

6.3.1 Tyres

Tyres, description

See *Workshop manual R60-55/60/70/80*.

6.3.2 Rim

Rim, description

See *Workshop manual R60-55/60/70/80*.

6.3.3 Nut with washer

Nut with washer, description

See *Workshop manual R60-55/60/70/80*.

7.2.3 Main valve

Main valve, description

See section 10 *Common hydraulics*, group 10.5.2 *Main valve*.

7.2.4 Lift cylinder

Lift cylinder, description

See *Workshop manual R60-55/60/70/80*.

7.2.5 Accumulator, damping

Accumulator damping, description

See *Workshop manual R60-55/60/70/80*.

7.2.6 Mast

Mast, general

See *Workshop manual R60-55/60/70/80*.

7.2.7 Mast wheels

Mast wheels, description

See *Workshop manual R60-55/60/70/80*.

7.2.8 Chains

Chains, description

See *Workshop manual R60-55/60/70/80*.

7.2.9 Chain wheels

Chain wheels, description

See *Workshop manual R60-55/60/70/80*.

7.2.10 Fork assembly

Fork assembly, description

See *Workshop manual R60-55/60/70/80*.

7.2.11 Lowering brake valve

Lowering brake valve, description

The load control valves are screwed into the directional valve for lift.

For more information, see *Workshop manual R60-55/60/70/80*.

7.2.12 Pipes and hoses

Pipes and hoses, description

See *Workshop manual R60-55/60/70/80*.

7.2.13 Reduction valve/distribution block

Reduction valve/distribution block, description

See *Workshop manual R60-55/60/70/80*.

7.7.5 Tilt cylinder

Tilt cylinder, description

See *Workshop manual R60-55/60/70/80*.

7.7.6 Mast

Mast, description

See *Workshop manual R60-55/60/70/80*.

7.7.7 Pipes and hoses

Pipes and hoses, description

See *Workshop manual R60-55/60/70/80*.

7.7.8 Reduction valve/distribution block

Reduction valve/distribution block, description

See *Workshop manual R60-55/60/70/80*.

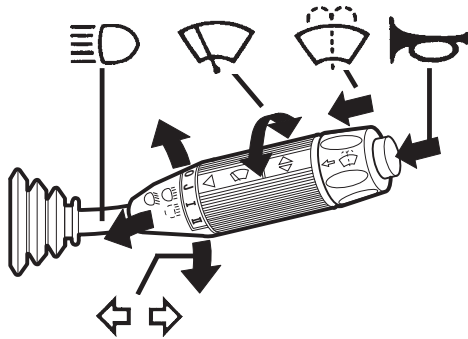

Multi-function lever

000896

9.1.1 Multi-function lever

Multi-function lever, description

The following functions are managed by the multi-function lever (position 5).

Movement

- Forward/Reverse
- Up
- Down
- Inward, button
- Inward, handle
- Rotation

Function

- Driving direction indicator
- Light signal
- Full beam (on/off)
- Acoustic signal (horn)
- Windscreen washer (also activates washing of roof and rear windows)
- Windscreen wiper, front
- 0 = switched off
- J = Interval wiping
- I = Continuous wiping
- II = position I

9.1.2 Switch, seat heating

Switch, seat heating, description



Switch (green), seat heating (position 29).

Position 0 – Seat heating off.

Position 1 – Seat heating on (symbol lit).

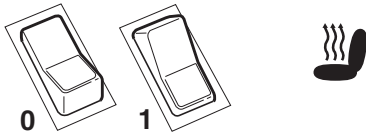

000324

9.1.11 Switch, windscreen wiper, roof

Switch, windscreen wiper, roof, description



Switch (green), for windscreen wiper on roof window (position 36).

Position 0 – Windscreen wiper off.

Position 1 - Windshield wiper on.

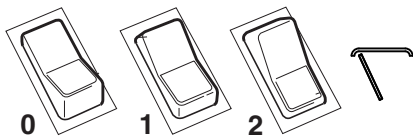

001278

9.1.12 Switch, windscreen wiper, rear

Switch, windscreen wiper, rear, description



Switch (green), for windscreen wiper on rear window (position 37).

Position 0 – Windscreen wiper off.

Position 1 - Windshield wiper on.

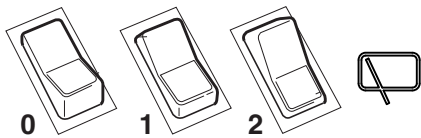

001277

CLICK HERE TO **DOWNLOAD** THE COMPLETE MANUAL

- Thank you very much for reading the preview of the manual.
- You can download the complete manual from: www.heydownloads.com by clicking the link below



- Please note: If there is no response to CLICKING the link, please download this PDF first and then click on it.

CLICK HERE TO **DOWNLOAD** THE COMPLETE MANUAL

9.6 Lighting system

Lighting system, description



It is important that the correct type of bulb is used for each light fitting.

The lighting is as follows:

- Headlights (with main and dipped beam)
- Position light
- Rear light, red
- Brake light
- Reversing light, white
- Driving direction indicator
- Rotating warning light
- Interior lighting
- Engine compartment light
- Lighting kit 1

Lighting kit 1 includes:

Headlights

Driving direction indicator

Running lights

Running lights, front

Rear light, red

Brake light

Reversing light, white

- Lighting kit 2

Lighting kit 2 includes:

Headlights

Driving direction indicator

Running lights

Running lights, front

Rear light, red

Brake light

Reversing light, white

Reflector, rear

License plate bracket with lighting

9.12 Chassis

Chassis, description

The chassis consists of two longitudinal frame sides cut from a single massive steel plate. Fenders, footsteps, tanks and counterweights are bolted to the frame.

In the frame there are mounting points for steering axle and cab. Mounts for motors, drive axle, electrical distribution box and hydraulic tank, see under respective function. The fenders are bolted to the frame.

The space in the frame's rear part is used for counterweights, quantity and size are adapted to the machine in question.

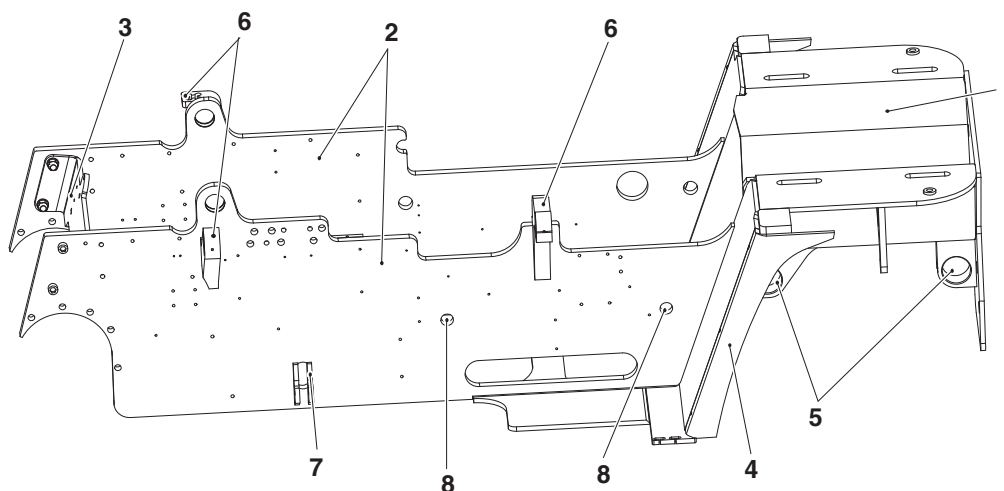

003456

1. Frame rear section
2. Frame sides
3. Cross stay
4. Rear fenders
5. Steering axle mounting
6. Cab mounting
7. Bracket for cab tilt cylinder
8. Mounting points for hydraulic tank

10.3 Tanks and accumulators

10.3.1 Tank

Tank, description

See *Workshop manual R60-55/60/70/80*.

10.3.2 Accumulators

Accumulators, description

See *Workshop manual R60-55/60/70/80*.

Pressure monitors' setting, checking

- 1 Machine in service position.
- 2 Tilt the cab.
- 3 Connect the dial gauge to measuring outlet (position C) on the reducer valve/distribution block.
- 4 Tilt back the cab.
- 5 Turn the main key to position I.
- 6 Check MAX pressure as follows:
 - Turn the wheel and let the pump charge the accumulator to MAX pressure
 - Read off the dial gauge, correct value is 14,0 MPa.
 - Turn the wheel and repeat the test.
- 7 Check MIN pressure as follows:
 - Turn the wheel to reduce the pressure in the accumulator and note when the pump motor starts.
 - Read off the dial gauge, correct value is 11,0 MPa.
 - Turn the wheel and repeat the test.

For adjusting pressure monitors, see *Workshop manual R60-55/60/70/80*.

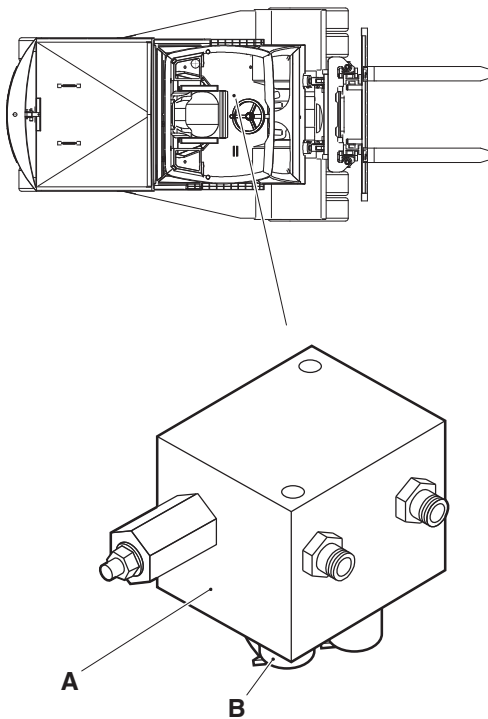

- A. Reduction valve/distribution block
B. Measuring outlet for MAX pressure in accumulator

003436

Troubleshooting with multimeter

Use a multimeter with high internal resistance, voltage measurement min. 80V, DC. All measurements shall be performed with the battery's minus connection as reference.

To obtain pump function, the following conditions must be fulfilled:

1. No error message on display in cab.
2. Hydraulic servo:
 - Lift: 80 V on input F7 as well as analogue signal from pressure sensor, lift on input D1. The voltage must be between approx. 2,1-9,5 V. However, the voltage must be between the calibrated values. See service manual 920937.9310, section "Calibrating lift lever".
 - Tilt: 80V on input F5. For adjusting pump speed, see service manual 920937.9310, section "Parameters".
 - Sideshift: 80 V on input F2. For adjusting pump speed, see service manual 920937.9310, section "Parameters".
 - Extra (4th function): 80 V on input F3. For adjusting pump speed, see service manual 920937.9310, section "Parameters".
3. Charging of accumulator.
 - 80 V on input F1 when pressure is lower than 110 bar
 - 80 V on input F4 when pressure is lower than 140 bar.

See also *Section E Diagrams*.

NOTE

Keep in mind that the drive is almost silent. Max. drive current may be triggered without it being heard.

10.4.6 Cooling pump motor

Cooling fan pump motor, description



On the pump motor there is a temperature sensor that starts the pump motor's cooling fan if the temperature of the motor's casing exceeds 50 °C. Another temperature-controlled switch on the motor's casing acts like overheating protection and activates a warning light at approx. 110 °C and a buzzer sounds.

10.4.7 Pressure sensor

Pressure sensor, description

The pressure sensor increases the pump motor's rpm proportional to the lift lever's position. Applies to lift function.

See *Workshop manual R60-55/60/70/80*.

11 Common electrical

Common electrical, safety

WARNING

The battery's electrolytes comprise water and corrosive sulphuric acid.

Avoid contact with skin and eyes. Risk of corrosive injuries!

Rinse thoroughly with water in the event of contact with the battery water.

WARNING

Risk of explosion exists with welding work (hydrogen gas forms at battery terminal).

Risk of explosion.

Disconnect the battery using the battery disconnect switch.

CAUTION

Always turn off the current when working on the electrical system, when the machine is not going to be used for some time, and for welding work on the machine.

CAUTION

Do not clamp electrical cables to pipes or hoses.

Fire hazard!

Fuse 51-4 and the contactor are located in the electrical cabinet

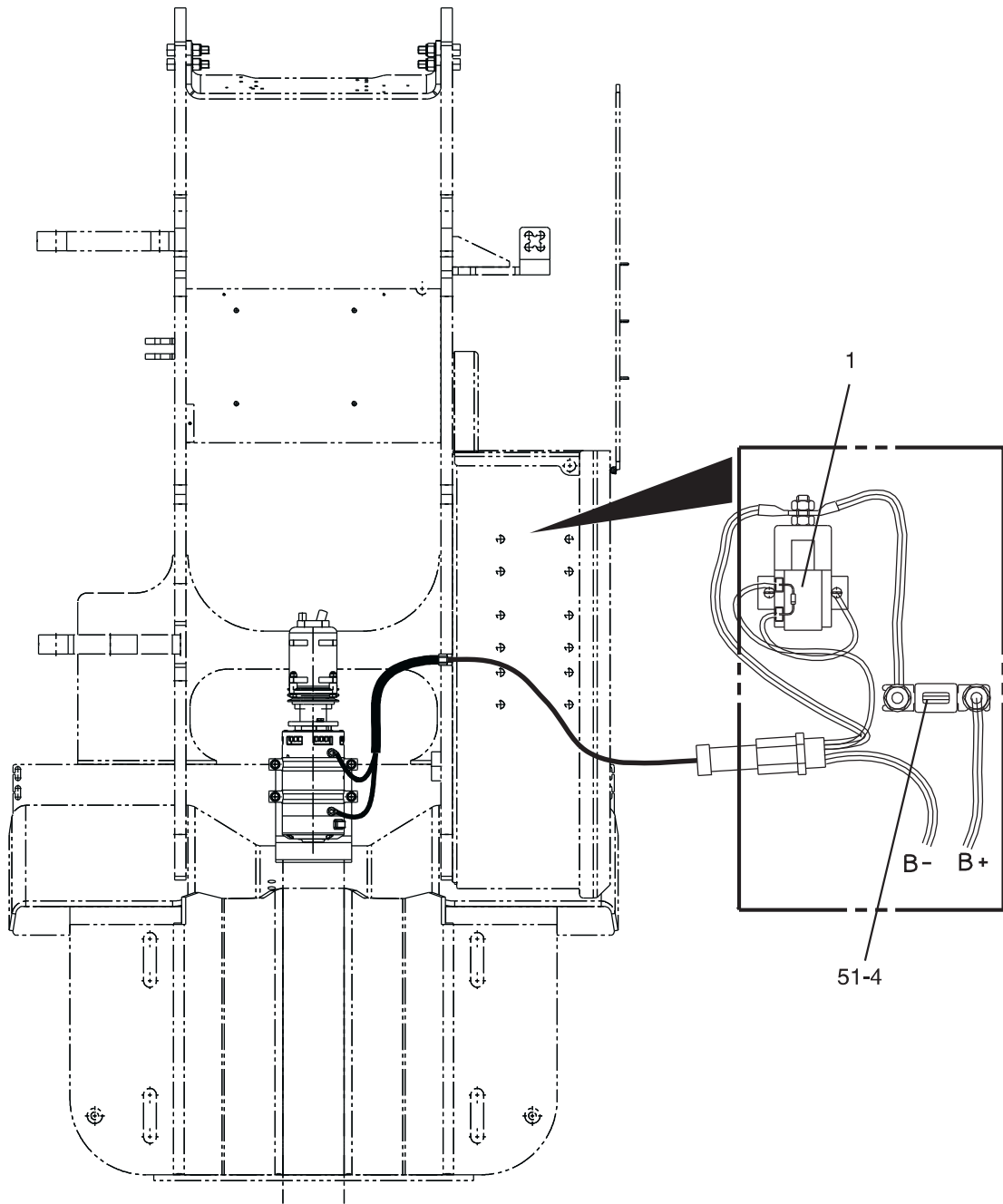

1. Contactor

003384

Drive regulator

The drive regulator receives signals from:

- Speed pedal, seat switch, main key and pump regulator
- Travel direction selector and brake pedal

These signals control the drive regulator which in turn controls the current to the drive motor. The function for components in the speed pedal and other associated units are described in the component list.

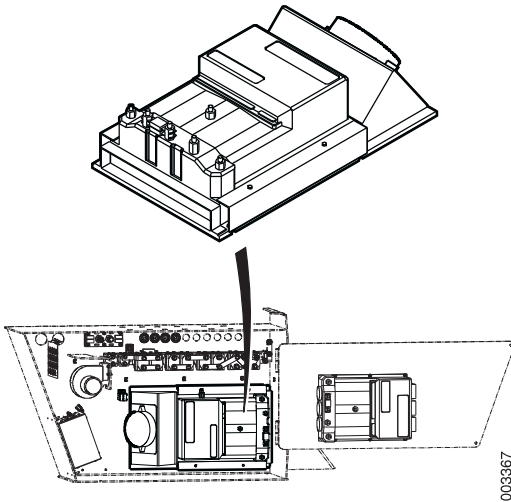

11.5.4 Operation, electrical system

Operation, electrical system, description

The electrical distribution box and supply to the circuits are activated when the main key is turned to the operating position.

Error code	Description	Limit	Recommended action
AL39	<p>Recharging contactor closed</p> <p>Problem appears while operating when the accelerator pedal is let up and recharging is to start. The alarm is shown when the recharging contactor does not release and VMN-voltage remains higher than 2/3 of the battery voltage.</p>	No drive.	<p>Possible malfunctions</p> <ul style="list-style-type: none"> • Recharging contactor remains closed. Disconnect the contact surfaces and clean them. If the contactor or contact surfaces seem damaged, change contactor 381. • If the contactor plates cannot be disconnected and remains activated, there is an error in the logic unit or in the cables to the contactor. To find out which, activate the operating position and press on the accelerator pedal without activating the seat switch. If the recharging contactor closes when the pedal is pressed down loosen the cable in terminal box C, pin 5 on the H3-panel. If the contactor still closes the cable is short-circuited to 80 volt minus, check cabling on the panel. If the contactor does not close the problem is in the logic unit, change the H3-unit. <p>After changing the H3-unit, parameters must be set. For further instructions, see Service manual 920937.9310 for programming unit 923368.0005.</p>

Table of Contents E Diagrams

10	Common hydraulics	3
	Hydraulic diagrams, compilation	3
	Hydraulic diagram A46312.0100	4
	Hydraulic diagram A46313.4100	6
	Hydraulic diagram A46313.4200	8
11	Common electrical	10
	Circuit diagram, description	10
	Component designations, description	11
	Component list	11
	Circuit diagrams R60-55/60/70/80, A45963.0100, compilation	56

Component designations, description

Table 4. Table for post type designations at contact description.

Designation	Description
G	Alternator, power supply module. Example: fuse.
M	Motor. Example: electric motor.
R	Resistance. Example: potentiometer.

Component list

Komponentförteckning/List of components/Komponenten- verzeichnis/Liste de composants

In the following component list the meaning of the figures in each wiring diagram can be determined.

303	K	Relä lastljus	Relay, mast light	Relais, Ladescheinwerfer	Relais, projecteur de chargement
304	K	Relä arbetsljus	Relay, working light	Relais, Arbeitsbeleuchtung	Relais, projecteur de travail
305	K	Relä backljus	Relay, reversing light	Relais, Rückfahrcheinwerfer	Relais, feux de recul
306	K	Relä heljuss	Relay, main beam	Relais, Fernlicht	Relais, feux de route
307	K	Relä halvljus	Relay, dipped beam	Relais, Abblendlicht	Relais, feux de croisement
308	K	Relä bromsljus	Relay, brake light	Relais, Bremslicht	Relais, feux stop
309	K	Relä parkeringsbroms	Relay, parking light	Relais, Standlicht	Relais, feux de stationnement
310	K	Relä körvisare vä	Relay, direction indicator left	Relais, Fahrtrichtungsanzeiger, L	Relais, clignotant supplémentaire, ga.
311	K	Relä körvisare hö	Relay, direction indicator right	Relais, Fahrtrichtungsanzeiger, R	Relais, clignotant supplémentaire, dr.
312	K	Relä startelement	Relay, element preheater	Relais, Startelement	Relais, élément de démarrage
313	K	Relä vändbar förarstol	Relay, rotating driver's seat (VBFS)	Relais, drehbarer Fahrersitz	Relais, siège pivotant
314	K	Relä parkeringsbroms	Relay, parking brake	Relais, Feststellbremse	Relais, frein de stationnement
315	K	Relä startlås	Relay, starting key	Relais, Startschloß	Relais, démarreur antivol
316	K	Relä torkare	Relay, wiper	Relais, Wischer	Relais, essuie-glace
317	K	Relä strålkastartorkare	Relay, roading lights wiper	Relais, Scheinwerferwischer	Relais, essuie-phare
318	K	Relä AT-regulator	Relay, AT-regulator	Relais, Abgasdruckregler	Relais, régulateur AT
319	K	Relä varningsblinkers	Relay, hazard blinkers	Relais, Warnblinker	Relais, feux de détresse
320	K	Relä elektrisk stopp	Relay, electrical stop	Relais, elektrischer Stopp	Relais, arrêt électrique
321	K	Relä intervalltorkare	Relay, intermittent wiper	Relais, Intervallwischer	Relais, balayage intermittent
322	K	Relä kylvätskenivå	Relay, coolant level	Relais, Kühlfülligkeitsstand	Relais, niveau radiateur
323	K	Relä blinkers	Relay, blinkers	Relais, Blinker	Relais, clignotants
324	K	Relä ragespär	Relay, range interlock	Relais, Rangesperre	Relais, blocage doubleur
325	K	Relä blinkande bromsljus	Relay, flashing brake lights	Relais, blinkendes	Relais, feux stop clignotants

507	H	Varn lampa färdbroms	Warning lamp, brake	Warnlampe, Betriebsbremse	Voyant, frein de service
508	H	Varn lampa parkeringsbroms	Warning lamp, parking brake	Warnlampe, Feststellbremse	Voyant, frein de stationnement
509	H	Varn lampa nivå kylvatten	Warning lamp, coolant level	Warnlampe, Kühlflüssigkeitsstand	Voyant, niveau liquide de refroidissement
510	H	Kont lampa diff spärr	Indicating lamp, diff. interlock	Kontrolllampe, Differentialsperre	Témoin, blocage du différentiel
512	H	Varn lampa temp momentförst	Warning lamp, temperature converter	Warnlampe, Temperatur Drehmomentwandler	Voyant, température du convertisseur
514	H	Kont lampa överväxel	Indicating lamp, overdrive clutch	Kontrolllampe, Overdrive	Témoin, overdrive
519	H	Kont lampa halvljus	Indicating lamp, dipped lights	Kontrollleuchte, Abblendlicht	Témoin, feu de croisement
524	H	Kont lampa luftfilter	Indicating lamp, air filter	Kontrolllampe, Luftfilter	Témoin, filtre à air
525	H	Kont lampa UNIKAT	Indicating lamp, UNIKAT	Kontrolllampe, UNIKAT	Témoin, UNIKAT
528	H	Kont lampa förvärmning	Indicating lamp, preheating	Kontrolllampe, Vorwärmung	Témoin, préchauffage
530	H	Kont lampa framhjuls styrning	Indicating lamp, forward wheel steering	Kontrolllampe, Vorderrad lenkung	Témoin, roue avant directrice
531	H	Kont lampa 4-hjuls styrning	Indicating lamp, 4-wheel steering	Kontrolllampe, Vierradlenkung	Témoin, 4 roues directrices
532	H	Kont lampa crab styrning	Indicating lamp, crab steering	Kontrolllampe, Diagonal lenkung	Témoin, dépacement en diagonal
533	H	Kont lampa hyd.pump	Indicating lamp, emergency hyd. pump	Kontrolllampe, Ackumulatorladepumpe	Témoin, pompe hydraulique d'urgence
547	H	Varn lampa centralvarning	Warning lamp, central warning	Warnleuchte, Zentrales Warnsystem	Voyant, signalisation centralisée
549	H	Varn lampa oljetryck v-låda	Warning lamp, oil pressure gear box	Warnlampe, Öldruck Getriebe	Voyant, pression d'huile de la boîte
550	H	Varn lampa hyttlåsning	Warning lamp, cab lock	Warnlampe, Kabinverriegelung	Voyant, verrouillage de la cabine
551	H	Varn lampa temp v-låda	Warning lamp, temperature gear box	Warnlampe, Temperatur Getriebe	Voyant, température de la boîte de vitesses

781	A	Reglersystem pumpmotor (EC)	Control system pump motor (EC)	Regelsystem Pumpenmotor (EC)	Système de régulation moteur de la pompe (EC)
782	A	Logik interface 2 drivmotorer	Logic (interface) two main motors (EC)	Logik (Schnittstelle) zwei Antriebsmotoren	Interface deux moteurs de propulsion
783	A	Logik interface gaspådrag	Logic (interface) throttle	Logik (Interface) Gasgeben	Interface de commande de frein
784	A	Logik interface bromsregl	Logic (interface) brake control	Logik (Interface) Bremssteuerung	Interface de commande de frein
785	A	Logik interface styrsystem	Logic (interface) control system	Logik (Interface) Lenkung	Interface de système de commande
786	A	Servoförstärkare styrsystem	Servo amplifier steering system	Servoverstärker, Steuerungssystem	Amplificateur pour le servo commande du système de direction
789	B	Givare allmän	Transmitter, common	Geber, allgemein	Capteur, général
790	D	Elektronisk kontrollenhet ECU, hytt	Electronic Control Unit ECU, cab	Elektronische Kontrollenheit ECU, Kabine	Unité de control électronique ECU, cabine
791	D	Elektronisk kontrollenhet aggregat	Electronic Control Unit, attachment	Elektronische Kontrollenheit, Aggregat	Unité électronique de control accessoire
792	D	Elektronisk kontrollenhet styrning	Electronic Control Unit, steering system	Elektronische Kontrollenheit, Lenkung	Unité électronique de control système de direction
793	D	Elektronisk kontrollenhet växellåda	Electronic Control Unit, gearbox	Elektronische Kontrollenheit, Getriebe	Unité électronique de control boite de vitesse
794	D	Elektronisk kontrollenhet motor	Electronic Control Unit, engine	Elektronische Kontrollenheit, Motor	Unité électronique de control boite moteur
795	P	Display	Display	Display	Afficheur
796	D	Elektronisk kontrollenhet, lasthantering	Electronic Control Unit, Loadhandling	Elektronische Kontrollenheit, Ladengerät	Unité électronique de control pour la manutention de la charge
797	D	Elektronisk kontrollenhet, ram	Electronic Control Unit, frame	Elektronische Kontrollenheit, Rahmen	Unité de control électronique ECU, chassis
799	A	Logik allm (option)	Logic, general (option)	Logik, allgemein (option)	Circuit logique, général (option)

			position			conduite
6054	Y	M-ventil, klämma ihop	Solenoid valve, clamping in	Magnetventil, zuklammern	Electrovanne, serrage	
6055	Y	M-ventil, klämma isär	Solenoid valve, clamping out	Magnetventil, aufklammern	Electrovanne,déserrage	
6056	Y	M-ventil, främre knä ut	Solenoid valve, front knee out	Magnetventil, vorderes Knie ausklappen	Electrovanne, sortie d;articulation avant	
6057	Y	M-ventil, främre knä in	Solenoid valve, front knee in	Magnetventil, vorderes Knie einklappen	Electrovanne,rentrée d;articulation avant	
6058	Y	M-ventil, bakre knä ut	Solenoid valve, rear knee out	Magnetventil, hinteres Knie ausklappen	Electrovanne,sortie d;articulation arrière	
6059	Y	M-ventil, bakre knä in	Solenoid valve, rear knee in	Magnetventil, hinteres Knie einklappen	Electrovanne,rentrée d;articulation arrière	
6060	Y	M-ventil, främre ben upp	Solenoid valve, front legs up	Magnetventil, vorderes Bein hoch	Electrovanne, position haute jambes avants	
6061	Y	M-ventil, bakre ben upp	Solenoid valve, rear legs up	Magnetventil, hinteres Bein hoch	Electrovanne,position haute jambes arrières	
6062	Y	M-ventil, urkoppling hydraulpump	Solenoid valve interruption hydraulic pump	Magnetventil, auskuppeln Pumpe	Electrovanne, coupure de pompe	
6063	Y	M-ventil, stödben upp	Solenoid valve, brace up	Magnetventil, Stuetzbein oben	Electrovanne béquille levée	
6064	Y	M-ventil, stödben ner	Solenoid valve, brace down	Magnetventil, Stuetzbein unten	Electrovanne béquille baissée	
6065	Y	M-ventil, frikoppling vridbroms	Solenoid valve, lockup rotation brake			
6066	Y	M-ventil, v-låda, drivning	Solenoid valve, gearbox, drive			
6067	Y	M-ventil, v-låda, oljetryck till 1:a/3:e växeln	Solenoid valve, gearbox,oilpressure to 1st/3rd gear			
6068	Y	M-ventil sax/rotation	Solenoid valve extender/rotation			
6069	Y	M-ventil, v-låda, oljetryck till 2:a/4:e växeln	Solenoid valve, gearbox,oilpressure to			

Complete machine

Dimensions and weight

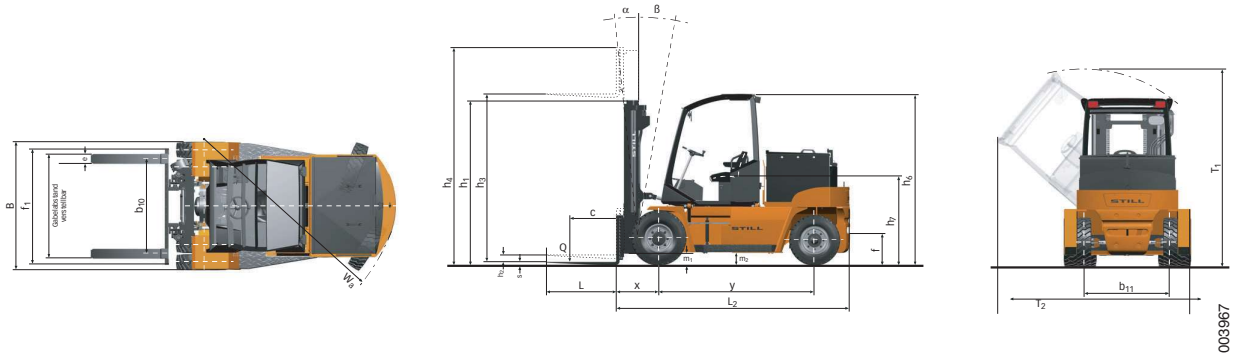

Model		R60-55	R60-60	R60-70	R60-80
Drive		Electric			
Operator		Cab with seat			
Load capacity	Q (kg)	5500	6000	7000	8000
Centre of gravity distance	C (mm)	600			
Distance c/c drive axle forks' front ladle surface	X (mm)				
Wheel base	Y (mm)	2100	2450		2600
Weight	kg				
Axle pressure, front (with classed load)	kg	12900	13400	15250	16500
Axle pressure, rear (with classed load)	kg	900		1050	1150
Axle pressure, front (without classed load)	kg	4100	4300	4500	
Axle pressure, rear (without classed load)	kg	4300	4000	4800	5150
Wheel type		pneumatic	pneumatic	pneumatic	pneumatic
Wheel size, front		315/70-15	8.25-15		
Wheel size, rear		29x9-15	8.25-15		
No. of wheels, front (x=drive wheel)		2x	4x		
No. of wheels, rear (x=drive wheel)		2			
Track width, front	b 10 (mm)	1530	1700		

1 Engine

Engine, technical data

Drive motor	31 kW
-------------	-------

Table of Contents G Terminology and index

Terminology and index	3
Terminology	3
Index	6

CLICK HERE TO **DOWNLOAD** THE COMPLETE MANUAL

- Thank you very much for reading the preview of the manual.
- You can download the complete manual from: www.heydownloads.com by clicking the link below



- Please note: If there is no response to CLICKING the link, please download this PDF first and then click on it.

CLICK HERE TO **DOWNLOAD** THE COMPLETE MANUAL