

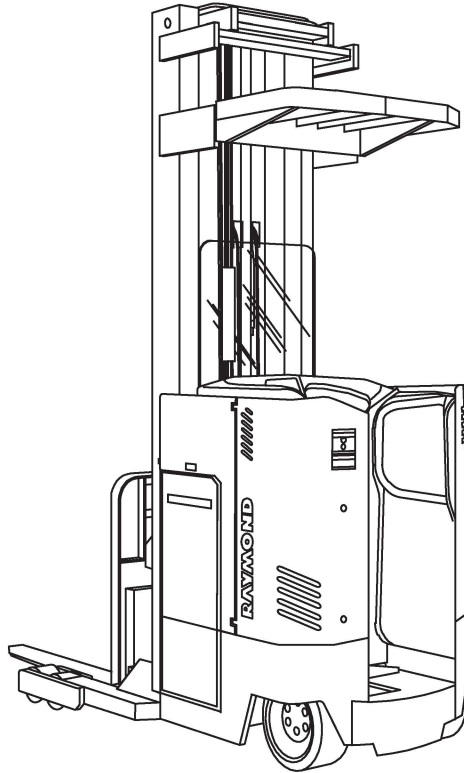

Maintenance Manual

EASi Reach-Fork[®] Lift Truck



Model	Series
<i>EASi Reach-Fork</i>[®] Lift Truck	EZ-A
	ET-A
	ES-B
	ET-B
	DS-B
	DT-B
	EF
	EZ-B
	DZ-B

PDMM-0080
PDMM-0080-01

Issued: 7-31-00
Revised: 9-1-01

CLICK HERE TO **DOWNLOAD** THE COMPLETE MANUAL

- Thank you very much for reading the preview of the manual.
- You can download the complete manual from: www.heydownloads.com by clicking the link below



- Please note: If there is no response to CLICKING the link, please download this PDF first and then click on it.

CLICK HERE TO **DOWNLOAD** THE COMPLETE MANUAL



Product Improvement Notices Included

Document Number	Subject	Date
RCH-97-R008	Firmware version 5.2	5-13-97
RCH-97-R011	Tilt cylinder seal kit	5-19-97
RCH-97-R012	Firmware version 5.8 for 4-motor lift trucks	6-26-97
RCH-97-R013C	Inertial Dampener Service	7-27-99
RCH-97-R016A	Start Interlock Button Option	10-20-97
RCH-97-R018C	Brake Gap Adjustment	1-27-99
RCH-97-R019	Mast Mounting Hardware	11-25-97
RCH-98-R001	External Brake Fluid Reservoir	2-19-98
RCH-98-R002	Drive unit grease fittings	8-5-98
RCH-98-R003	Fault Code AK	10-28-98
RCH-98-R004	Serial number locations	11-16-98
RCH-98-R005	Control handle cable loop	12-31-98
RCH-99-R002	Firmware version 6.5	2-9-99
RCH-99-R004	Firmware version 6.7	11-17-99
RCH-99-R005	Cold Storage indicator lights on panel	7-19-99
RCH-99-R006A	Back cylinder with threaded anchor retention	7-11-2000
RCH-00-R002	Firmware version 6.8	5-31-2000
RCH-00-R005	Hydraulic Pump Mounting to Electric Motor	12-15-2000

General Safety

Do NOT operate or work on this lift truck unless you are trained, qualified, and authorized to do so, and have read the Owner/Operator Manual.

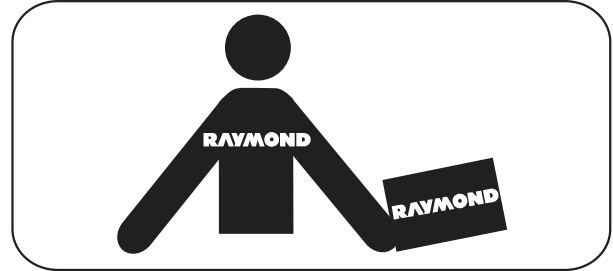

Know the lift truck's controls and what they do.

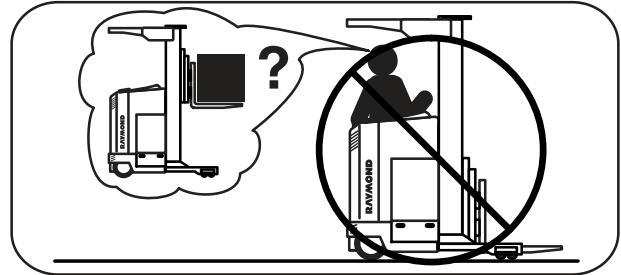

Do NOT operate this lift truck if it needs repair or if it is in any way unsafe.

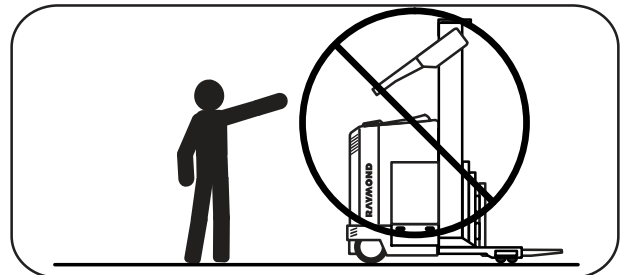

Operate this lift truck only from the operator's position.

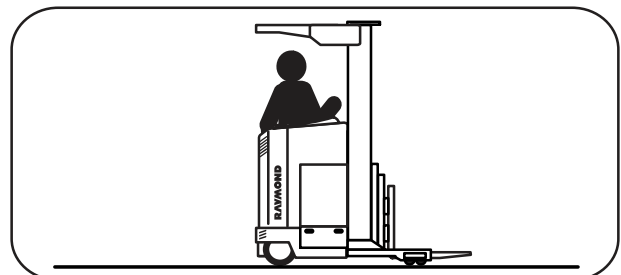

Jacking Safety

Sometimes you may need to jack the lift truck off the floor to perform maintenance procedures. When doing so, observe the proper safety precautions:

1. Lower the forks completely. Remove any load.
2. Place all controls in neutral.
3. Block the wheels to prevent movement of the vehicle.
4. Turn the key switch OFF and disconnect the battery connector.
5. If possible, stabilize the top of the mast with an overhead chain hoist.
6. Before jacking the lift truck, check the A-frame down-travel adjustment bolt. See [Figure 2-3](#). If the bolt is missing, or the hole through which it passes is excessively worn, the A-frame will not be held in place when the lift truck is jacked up; the A-frame could pivot down and allow the springs to fall out.
7. Place the jack under the designated jacking points. See [Figure 2-4](#).

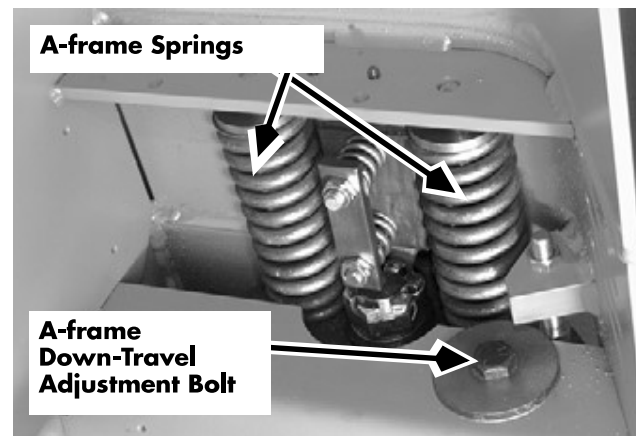

Figure 2-3: Verify A-frame Down-Travel Adjustment Bolt

⚠ WARNING

Use extreme care whenever the lift truck is jacked up. Never block the lift truck between the telescopic and the floor. Use a suitable hoist to stabilize the mast. Keep hands and feet clear from vehicle while jacking the lift truck. After the lift truck is jacked, place solid blocks or jack stands beneath it to support it. DO NOT rely on the jack alone to support the lift truck.

4-D® Display (Series EF only)

The 4-D control panel and display is a membrane circuit panel mounted on the mast guard.

The circular lighted pad in the upper right of the 4-D control panel symbolizes the direction of the 4-D caster wheel. Cross hair LEDs indicate the caster direction. When the ROTATE button is pressed, both cross hairs illuminate until the caster rotation is completed. When caster wheel rotation completes normally, the cross hair LEDs then indicate the direction of the caster, either fore-aft (front) or crab (sideways).

The “C” shaped lighted pad in the lower left of the 4-D control panel indicates the rotation direction of the drive wheel. Two arrows, one at the 12 o'clock position, the other at the 9 o'clock position, indicate optimum position of drive wheel for forward and side travel, respectively.

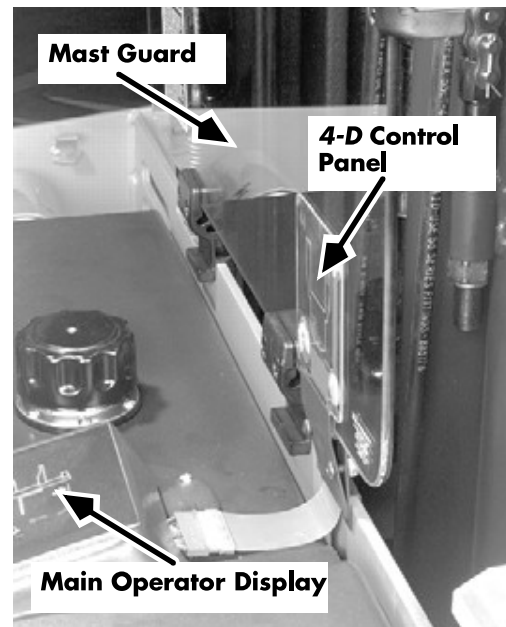

Figure 3-5: 4-D Control Panel, Series EF

4-D Display legend (see figure at right):

1. 4-D caster direction indicator
2. Rotate button
3. Drive wheel position indicator
 - a. Solid green LED means drive wheel positioned properly in relation to 4-D caster.
 - b. Flashing green LED means drive wheel approaching improper angle in relation to 4-D caster.
 - c. Red LED means drive wheel is at an improper angle in relation to the 4-D caster. Travel is inhibited but plugging is allowed. Turn the steering wheel to rotate the drive wheel until a green LED is illuminated.

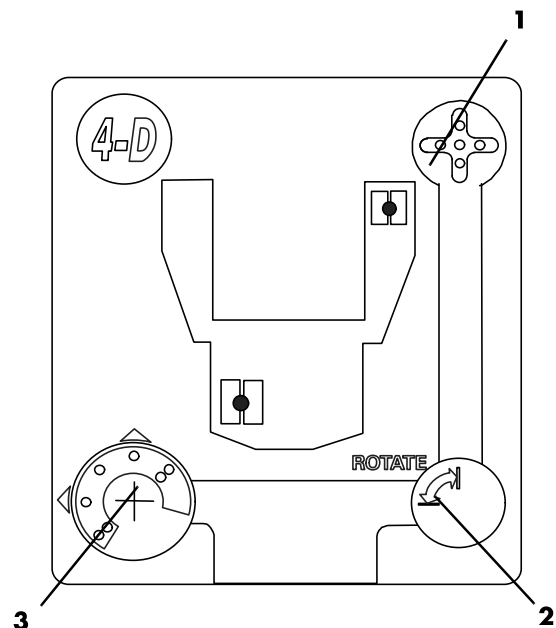

Figure 3-6: 4-D Display, Series EF



Every 60 Days or 250 Deadman Hours (HD)

Every 60 Days or 250 Deadman Hours (HD)		
Item No.	Component	What to do
See "Scheduled Maintenance Points" beginning on page 4-11.		
	Electrical Cables	Inspect all power cables for nicks or cuts. Give special attention to those cables which are not stationary, for example, cables to the drive motor. Replace any cable that is damaged or shows signs of excessive heat. Failure to do so will cause intermittent system shutdowns and/or electronic failures. Check the tension of the over-the-mast pulley cables. Set tension so the cables just stay on the pulleys. Higher tension will cause premature failure. Maximum spring tension is 5 to 7 in. lbs. (0.57 to 0.79 Nm).
11	Forks	Check for excessive wear, bends, cracks, welding arcs, excessive heat, or unauthorized modifications. Replace if found. Check fork thickness (tool P/N 922-369).
	Hardware	Check tightness of all hardware connecting wires and cables. Check bolt torque of major components (motors, pumps, brake, drive unit, manifolds, mast-to-tractor mounting bolts). Tighten any loose hardware. Replace any broken or missing hardware.
14	Horn	Check that horn sounds properly when activated. Check mounting bracket insulators.
	Hydraulic Hoses	Inspect for leaks, nicks, cuts, chafing, and bulges. Replace damaged or worn hoses immediately. Inspect fittings for leaks; repair immediately.
15	Hydraulic Reservoir	Check fluid level and type. Inspect the plate over the clean-out hole for seepage. If found, apply new coat of sealant to plate.
	Learn Mode	Enter "Program Mode" and run "Learn."
16	Lift and Equalization Chains	Check adjustment. Inspect for excessive stretch or wear (tool P/N 950-350/CG). Lubricate.
	Lubrication	Apply grease to all fittings on carriage and tractor. Apply small amount of grease to steering gear on drive unit. Coat all chains with film of spray lubricant.



state, *Maintenance Minder* will offer a submenu with the options “QUIT MM” and “ENABLE.” Use the tilt control to select “ENABLE.” Press the horn button.

Setting Time Interval and Action Option

The first time you enter the time interval menu, the Factory Suggested setting, followed by the letters “FS,” will be displayed. Subsequently when you enter the time interval menu, the last used setting will be displayed. Values from 50 to 500 hours, in increments of 50, are available. Use the tilt control to scroll to the desired time interval. With the desired value displayed, press the horn button.

Use the tilt control to select the desired action option. Then press the horn button.

- “MSG ONLY” causes the Operator Display to show “SCHEDULED MAINTENANCE DUE” when the scheduled maintenance time interval has been exceeded.
- “L CUTOUT” causes the Operator Display to show “LIFT CUT OUT, SCHEDULED MAINTENANCE DUE” when the scheduled maintenance time interval has been exceeded. Lift will be disabled the next time the power circuits are cycled.

Use the tilt control to select “QUIT MM” from the submenu. If the status has changed, you will be prompted to save changes. Press the horn button.

NOTE: From the Config Menu, exit by selecting “QUIT CFG.” You will not be prompted again to save changes, but any changes saved when you “QUIT MM” will be retained.

Changing Time Interval or Action Option

When *Maintenance Minder* is active, and you wish to change the time interval or action option, enter Configure Mode.

With Configuration Mode selected, use the tilt control to display the “MNT MIND” item. Press the horn button. When entered from an enabled state, *Maintenance Minder* will offer a submenu with the options “QUIT MM,” “RESET,” “DISABLE,” and “SETUP.” Use the tilt control to select “SETUP,” then press the horn button. The



Electrical Troubleshooting Guidelines

Many problems are caused by a faulty or dirty battery. Make sure the battery is clean. See “Battery Exterior Cleaning” on page 7-112. Check the electrolyte level and state of charge. See “Testing, Charging, and Maintenance” on page 7-113.

⚠ WARNING

Be sure to jack and block the lift truck whenever a troubleshooting procedure requires turning key switch S1 ON. This will avoid accidents caused by unexpected travel. See “Jacking Safety” on page 2-13.

⚠ CAUTION

Unless otherwise directed, disconnect the battery connector when you check electrical circuits or components with an ohmmeter. Electrical current can damage the ohmmeter.

Save time and trouble by looking for simple causes first.

Visually inspect all wiring and electrical components for:

- Loose connections or connectors
- Loose or broken terminals
- Damaged terminals, blocks, or strips
- Exposed wire at terminations, excessive strip gap
- Abrasions, scrapes, nicks in the wire, damage from overheating or burns, or other general insulation damage
- Broken wire strands and shorted conditions (especially those that are close to metal edges or surfaces)



Troubleshooting Procedure

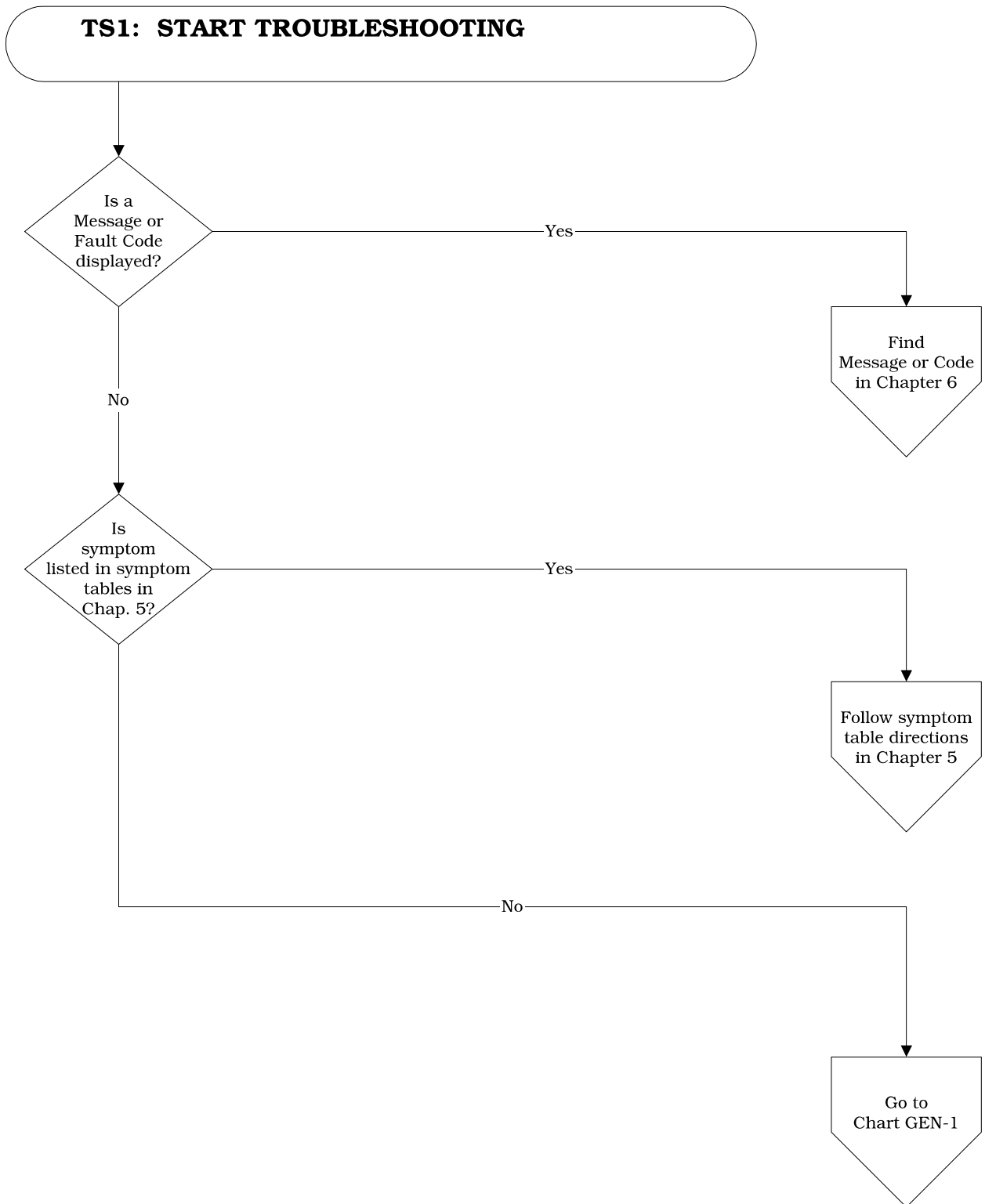

**Lift Function****No Lift**

Possible Cause	Action
Battery problems	Replace battery with fully-charged good battery.
Bad lift (P) Contactor, 8-coil driver board, or wiring.	Run test O02. Follow recommendations in test.
Bad lift/lower potentiometer VR2 or associated wiring	Run Test A05. Follow recommendations in test.
Relief valve REL1 stuck open	Check for contamination in hydraulic fluid. If contamination is present, flush, fill and bleed the hydraulic system and clean the relief valve. If no contamination is found, replace REL1.
Bad System Card, VFC, or firmware	Tests O02, O11, and O12 diagnosis and repair will call out.
Bad lift pump	Replace lift pump.
Bad lift motor	Test lift motor. See “Electric Motor Tests” on page 7-128.
Optional Lift Limit Switch is bad	Run Test I05. Follow recommendations in test.

Dead Lift Truck

Display is Dark; Lift Truck is NOT Operational

Possible Cause	Action
Battery problems	Replace battery with fully-charged good battery.
Bad battery cables or connector	Repair or replace as necessary.
Problem in key switch circuit. In 4-motor lift trucks, problem in K4 relay circuit.	Disconnect JPS7. Turn key switch ON. Measure continuity between JS7-6 and JS7-13. If no continuity, either key switch S1 or cable JS7 to key switch is bad. Measure continuity across terminals of S1. If no continuity, replace S1; if continuity, replace cable JS7. Turn key switch OFF.
Fuse FU3 may be blown	Remove fuse FU3 and test continuity. If continuity is missing, replace fuse.
Fuse FU4 may be blown	Remove fuse FU4, and test continuity. If continuity is missing, replace fuse.
Missing B+ due to bad wiring from battery positive through PC-1 to JPS14.	Reconnect JPS7. Disconnect JPS14. With key switch OFF, measure voltage from JPS14-12 to TP4 and from JPS14-13 to TP4. If battery voltage is not present, troubleshoot wiring problem between JPS14 and PC-1 or cable from battery positive to PC-1; if wiring is OK, look for missing B- below.
Missing B- due to bad wiring from JPS14 through TP4 to battery negative.	Disconnect JPS14. Measure voltage from PC-1 (+) to JPS14-1, JPS14-2, JPS14-3, and JPS14-4. If battery voltage is not present, troubleshoot wiring problem between JPS14 and TP4 or cable from TP4 to battery negative; if wiring is OK, look for missing B+ above.
Bad System Card	Measure for 12v on System Card test points. If 12v is running low, isolate components that run on 12v. Shorted component may be draining power supply. Reconnect JPS14. Turn key switch ON. Measure voltage between TP1 (+) and TP2 (-) on the System card. If B+ voltage is not present, replace system card.
<i>CONTINUED NEXT PAGE</i>	



Modes of Operation

Using Configure Mode

3. With **N (No)** selected, press the **horn** button. All changes are discarded.
4. If you entered via Superword, the Operator Display will show:

CONFIG

Use the tilt up/down buttons to select **QUIT PGM** and press the **horn** button. The Operator Display will show:

DONE

5. The lift truck enters Run Mode, beginning with SelfTest diagnostics.

To Reinstate Factory Default Settings

1. Enter Configure Mode and use the **tilt up** button to select **DEFAULT**. Press the **horn** button. The Operator Display shows:

RESET? N

Use the **tilt up/down** buttons to select **Y (Yes)**. Press the **horn** button.

2. Use the **tilt down** button to select the **QUIT CFG** item. Press the **horn** button.

3. The Operator Display will show:

SAVE? N

4. Use the **tilt up/down** buttons to select **Y (Yes)**. Press the **horn** button. Factory default settings are restored for all items except:

- Electronic Key
- Superword
- Password
- Mnt Mind

5. If you entered via Superword, the Operator Display will show:

DONE

6. The lift truck enters Run Mode, beginning with SelfTest diagnostics.



Messages and Codes Summary Tables

The following tables summarize informational, performance limiting, and fault codes.

NOTE: The following “Effect” designations are used throughout these tables:

“Effect” Designations			
0	0 mph speed limit	P	Minimum power (traction system)
1	1 mph speed limit	R	Top speed minus 2.0 mph (3.2 km/hr) and plugging only
D	Traction system derating	T	Traction system shutdown
I	Informational	U	Travel system disabled; plugging allowed
L	Lift system shutdown	W	Lowering system shutdown
N	2nd stage lift pump inhibited	X	Total shutdown

Informational / Performance Limiting			
Code	Condition	Effect	Related Tests
12	Lift motor temperature hot	N	A09
1H	Power panel overheated	I	A10, I12
1L	EPO Switch Detected Down	X	I01, A15
1N	Lift inhibit switch activated	L	I04, I05
1W	Unknown 4-D caster wheel position	U	I18
1X	4-D travel mode change requested while moving	I	none
1Y	Drive wheel position inhibits travel	U	none
1Z	Approaching restricted area	I	none

Power Panel Fault Codes			
Code	Condition	Effect	Related Tests
20	Temperature sensor circuits not responding	I	A10, I12
21	Short detected in armature circuit	T	A03, A11, O13, I13
23	Open detected in armature circuit	T	O00, O14, O21
24	Armature current sensor circuit not responding	T	A11, I13
25	Short detected in field circuit	T	A12, O15, O16, O17
26	Open detected in field circuit	T	A12, O15, O16, O17
28	Excessive acceleration	P	I16

**Code 23**

Code Title	Open Detected In Armature Circuit
Reason	During SelfTest, proper current levels were not sensed by CT1 (on the Power Card) from the Power Transistor (Q1).
System Response	<ol style="list-style-type: none"> 1. Alarm Sounds: Yes 2. Operator Display: Code 23. Inform Service. 3. PC contactor: Energized 4. Performance Limit: Traction system shutdown
How to Clear	Turn the key switch OFF/ON.

Checks:

1. Check fuse 5 (FU5).
2. Visually inspect 'B' Contactor tips for weld condition (if by-pass equipped).

Run Tests:

- [Test O00 - Toggle the PC Contactor \(Page 6-121\)](#)
- [Test O14 - Armature PWM \(v.4.5\) \(Page 6-149\)](#)
- [Test O14 - Armature PWM \(v.3.6\) \(Page 6-152\)](#)
- [Test O21 - Regen Enable Circuit \(Page 6-164\)](#)

Inspect the following components: (See [“Rectifiers” on page 7-168.](#))

- REC 1
- REC 2
- All other snubber circuit components
- Drive Motor (See [“Drive Motor” on page 7-132.](#))



Code 42

Code Title	Lift contactor detected closed when commanded open
Reason	The P Contactor is closed when it should be open.
System Response	<ol style="list-style-type: none"> 1. Alarm sounds: Yes 2. Operator Display: Code 42. Inform Service. 3. PC contactor: Energized P contactor: De-energized (EZ-B/DZ-B) 4. Performance Limit: Lift/Lower System Shutdown
How to Clear	Turn the key switch OFF/ON.

The P Contactor or its wiring may be bad.

The pump sense circuit may be bad.

Run Test:

- [Test O02 - Toggle the P Contactor \(Page 6-125\)](#)

Run test:

- [Test A02 - Lift Pump Sense Voltage \(Page 6-75\)](#)

Code 43

Code Title	Lift Contactor detected open when commanded closed
Reason	The P Contactor is open when it should be closed.
System Response	<ol style="list-style-type: none"> 1. Alarm sounds: Yes 2. Operator Display: Code 43. Inform Service. 3. PC contractor: Energized P contactor: Energized (EZ-B/DZ-B) 4. Performance Limit: Lift system shutdown
How to Clear	Turn the key switch OFF/ON.

The P Contactor or its related wiring may not be functioning correctly.

Run Test:

- [Test O02 - Toggle the P Contactor \(Page 6-125\)](#)

The Pump sense circuit may be bad.

Run Test:

- [Test A02 - Lift Pump Sense Voltage \(Page 6-75\)](#)

**Code AG**

Code Title	Communications to Operator Display Failed
Reason	The VFC communicates with the OD to store information such as Time On Deadman, etc. This occurs during power-up, and once for every hour on the deadman after that.
System Response	<ol style="list-style-type: none"> 1. Alarm sounds: Yes 2. Operator Display: Code AG. Inform Service. 3. PC Contactor: De-energized 4. Performance Limit: Total shutdown
How to Clear	Turn the key switch OFF/ON.

NOTE: None of the Program Modes (Maintenance, Learn, or Config) can be entered until this code is cleared.

Checks:**▲ CAUTION**

Be sure to observe proper precautions against electrostatic discharge. See "Static Precautions" on page 2-11.

1. The cable from the Operator Display may not be properly connected to the System Card, or damaged.
2. If problem remains, replace Operator Display, VFC, and Firmware (PROM). See "VFC Card" on page 7-175. Run Configure Mode, then Learn Mode.

NOTE: For instructions on selecting Modes of Operation, see "Modes of Operation" on page 6-5.



Code FH

Code Title	Battery voltage out-of-range
Reason	The battery volt sense analog input was detected out of range.
System Response	<ol style="list-style-type: none"> 1. Alarm sounds: Yes 2. Operator Display: Code FH. Inform Service. 3. PC contactor: De-energized 4. Performance Limit: Total shutdown
How to Clear	Turn the key switch OFF/ON.

The battery volt sense line or its related wiring and circuitry may not be functioning correctly.

Run Test:

- [Test A15 - Battery Voltage \(Page 6-100\)](#)

Code GB

Code Title	Caster wheel input sensor failure
Reason	4-D caster wheel input sensor failure
System Response	<ol style="list-style-type: none"> 1. Alarm sounds: Yes 2. Operator Display: Code GB. Inform Service. 3. 4-D Display: Caster wheel - all LEDs lighted; Drive wheel - all LEDs dark 4. PC contactor: Energized 5. Speed Limit: Traction system shutdown; brake not set
How to Clear	Turn the key switch OFF/ON.

NOTE: This code occurs only on *Fiddler*™ lift trucks beginning with serial numbers EF....

This code can result if the 4-D caster wheel is transitioned while rotating the steering wheel. Turn the key switch OFF/ON. If failure continues, **run test:**

- [Test I18 - Caster Wheel Inputs \(Page 6-120\)](#)

Vehicle Function Controller (VFC) Card

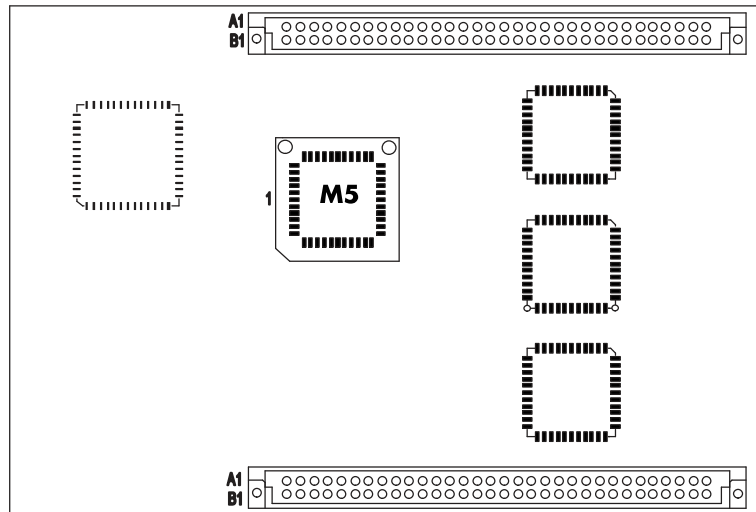

Figure 6-8: Vehicle Function Controller (VFC) Card

4-D® Circuit Card

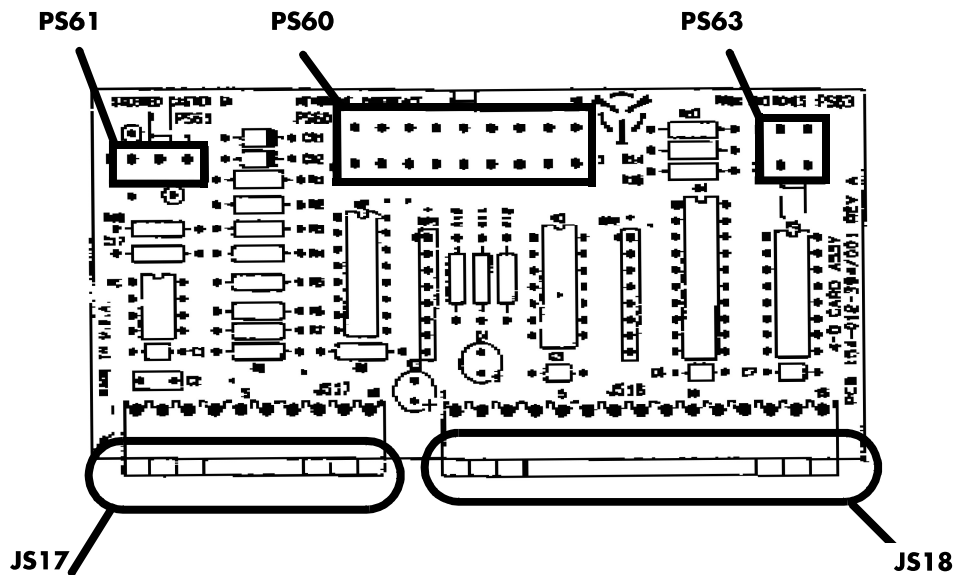

Figure 6-9: 4-D Circuit Card connectors



Analog Tests

Test A05 - Lift/Lower Potentiometer Voltage

on the top of the multi-function control handle. Remove the knob.

2. Run Analog Test A05. Manually set the potentiometer to 2.60 volts.
3. Carefully set the lift/lower knob on the lift/lower potentiometer shaft with the spring pin engaging the spring. Check the voltage shown on the Operator Display. With the lift/lower knob in its neutral position, it should be 2.60 volts.
4. Tighten the setscrews that hold the lift/lower knob to the potentiometer shaft.
5. Move the lift/lower knob to full lift. Check the voltage shown on the Operator Display. It should be from 0.4 to 1.5 volts.
6. Move the lift/lower knob to full lower. Check the voltage shown on the Operator Display. It should be from 4.0 to 4.9 volts.
7. Run Learn Mode for Controls.

NOTE: [For instructions on selecting Modes of Operation, see “Modes of Operation” on page 6-5.](#)

Lift/Lower Potentiometer Adjustment - Solid State

NOTE: Because of the ESD sensitivity of solid state potentiometers, handles P/N 828-009-630 and 828-006-161 are not field repairable, except for lift knob replacement. VR2 cannot be adjusted; entire control handle replacement is recommended.



Analog Tests

Test A09 - Lift Pump Motor Temperature Voltage

3. The System Card may be malfunctioning. Replace the System Card. Refer to “System Card” on page 7-172 for replacement procedure. Run Configure Mode, then Learn Mode. Re-run the test.

NOTE: For instructions on selecting Modes of Operation, see “Modes of Operation” on page 6-5.

Analog Tests

Test A14 - Power Supply +12 Voltage

Test A14 - Power Supply +12 Voltage

This test displays the voltage that the VFC is reading from the +12 volt power supply. A successful test proves that the power supply in the System Card is working properly.

NOTE: For information on how to use maintenance mode, see "Using Maintenance Mode" on page 6-14.

Run Test

1. The Operator Display will show the voltage which the System Card reads from the +12 volt power supply.
2. The test is a success if the voltage displayed is within these limits:

System Condition	Voltage Displayed
Lift truck at rest	11.0 to 13.0v

- If the reading fluctuates by more than 0.8 volts in 10 seconds, then the test is a failure. Perform diagnosis.

Diagnosis and Repair

⚠ CAUTION

Be sure to observe proper precautions against electrostatic discharge. See "Static Precautions" on page 2-11.

1. A component may be drawing the 12 volts from the System Card down. This could prevent a correct reading. Before replacing the System Card, check it as follows:
 - a. Connect a digital voltmeter as follows:
 - Positive (+) lead to PS5-9 on Power Card
 - Negative (-) lead to PS3-2 on Power Card

- b. Note the reading.
- c. Turn the key switch OFF and disconnect the battery connector.
- d. Disconnect one of the following components. Go on to step e.
 - The multi-function control handle at JPS4.
 - The Operator Display at JPS8.
 - The lift pressure sensor at JPS6.
 - The heat sink temperature sensor at JPC1.
 - JPS16.
 - The communications port at JPS9.
 - The REGEN card at JPC2.
 - JPS17 and JPS18 (4-D Series EF only).

- e. Reconnect the battery connector and turn the key switch ON. Note the voltmeter reading. If the voltmeter reading is now 11.0 to 13.0 volts, the power supply circuitry in the System Card is working properly. Repair or replace the component as necessary.
- f. Repeat steps 1c through 1e until you disconnect the component that was using 12 volts and the voltmeter reading becomes 11.0 to 13.0 volts.

2. If the voltage is not between 11.0 and 13.0 volts, the System Card may be malfunctioning. Replace the System Card. Refer to "System Card" on page 7-172 for replacement procedure. Run Configure Mode, then Learn Mode. Re-run the test.
3. If the problem remains, the VFC may be malfunctioning. Replace the VFC and firmware. Refer to "VFC Card" on page 7-175 for replacement procedure. Run Configure Mode, then Learn Mode. Re-run the test.

NOTE: For instructions on selecting Modes of Operation, see "Modes of Operation" on page 6-5.

Test I06 - Reach Switch

Using this test, the state of reach switch (S4) can be monitored. This test will show what the System Card is reading from the switch.

NOTE: For information on how to use maintenance mode, see “Using Maintenance Mode” on page 6-14.

Run Test

The display will show the state of the switch:

Reach Button	Audible Alarm	Operator Display
Depressed	Sounding	In
Released	Off	Out

If you do not obtain these results, then the test is a failure. Perform diagnosis.

Diagnosis and Repair

▲ CAUTION

Be sure to observe proper precautions against electrostatic discharge. See “Static Precautions” on page 2-11.

1. The harness from the switch may not be properly plugged into the System Card at JPS4. Inspect and verify the connection.
2. The switch may not be operating correctly electrically. Turn the key switch OFF and disconnect the battery connector. Disconnect JPS4 from the System Card. Connect an ohmmeter to the harness side of JPS4 between PS4-1 and PS4-14.

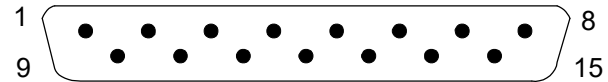

Figure 6-12: JPS4 pin connector orientation

You should see:

Reach Button	Resistance
Released	More than 2 megohms
Depressed	Less than 1 ohm

3. If you do not obtain these results, troubleshoot the switch and harness, if the control handle is field repairable. Control handles with solid state potentiometers or heaters are not field repairable; replace the entire handle.
4. The System Card may be malfunctioning. Replace the System Card. Refer to “System Card” on page 7-172 for replacement procedure. Run Configure Mode, then Learn Mode. Re-run the test.
5. If the problem remains, the VFC may be malfunctioning. Replace the VFC and firmware. Refer to “VFC Card” on page 7-175 for replacement procedure. Run Configure Mode, then Learn Mode. Re-run the test.

NOTE: For instructions on selecting Modes of Operation, see “Modes of Operation” on page 6-5.



Digital Input Tests

Test I17 - Drive Wheel Inputs

Test I17 - Drive Wheel Inputs**NOTE: Series EF only**

Test I17 reports the switch positions of the 4-D® proximity sensor S63.

A successful test indicates the proximity sensor is adjusted and functioning properly and that its associated wiring is electrically functional.

Run Test

1. Connect a digital voltmeter between the JPS63 harness pin listed in the table below (+) and TP4 (-).
2. Using the steering wheel, set the drive wheel to each position in the table below.
3. Visually verify the position of the drive wheel.
4. Compare the table below with the information displayed in the Operator Display. The switch sensor appears either over metal or over air with respect to the 4-D proximity sensor sensing ring. To identify slots and pins, see [Figure 7-167](#) and [Figure 7-168 on page 7-190](#).
5. If any of the listed values fails to appear, the test fails.

Expected Results

Drive Wheel Clock Position	Operator Display Message	Switch Location and Harness Pin		
		S63A Slot A	S63B Slot B	S63C Slot C
		JPS 63-3	JPS 63-1	JPS 63-2
12	I17 011	Metal 1.4v	Air 8.0v	Air 8.0v
10 to 11	I17 001	Metal 1.4v	Air 8.0v	Metal 1.4v
9	I17 101	Air 8.0v	Air 8.0v	Metal 1.4v
8 to 7	I17 100	Air 8.0v	Metal 1.4v	Metal 1.4v
1 to 4	I17 010	Metal 1.4v	Metal 1.4v	Air 8.0v

Other Failures

The following readings represent switch combinations which should never occur. Any of these readings indicate a test failure.

Drive Wheel Clock Position	Operator Display Message	Switch Location and Harness Pin		
		S63A Slot A	S63B Slot B	S63C Slot C
		JPS 63-3	JPS 63-1	JPS 63-2
UNKNOWN	I17 111	Metal 1.4v	Metal 1.4v	Metal 1.4v
UNKNOWN	I17 110	Air 8.0v	Air 8.0v	Metal 1.4v
UNKNOWN	I17 000	Air 8.0v	Air 8.0v	Air 8.0v

Diagnosis and Repair

1. The 4-D proximity sensor may be out of proper alignment. This cause is indicated if the lift truck has jerky motion under load.
2. The 4-D proximity sensor pickup may be bent or deformed.
3. Switch S63 or its wiring harness may be bad. Isolate and test continuity.
4. The drive unit bearing race may be worn.

⚠ CAUTION

Be sure to observe proper precautions against electrostatic discharge. See "Static Precautions" on page 2-11.

5. The 4-D circuit card may be malfunctioning. Replace the 4-D circuit card. See "4-D® Circuit Card" on page 7-180.

Digital Output Tests

Test O04 - Toggle Solenoid DIRA

Test O04 - Toggle Solenoid DIRA

Using this test, DIRA can be turned off and on, verifying its correct operation.

A successful test proves that the wiring and related circuitry in the VFC, System Card, and DIRA coil driver are all functioning correctly. It also proves that DIRA and its harness are electrically functional.

It does not prove that the DIRA solenoid itself is mechanically functional.

NOTE: For information on how to use maintenance mode, see “Using Maintenance Mode” on page 6-14.

Preparation

1. Turn the key switch OFF and disconnect the battery connector.

⚠ CAUTION

Be sure to observe proper precautions against electrostatic discharge. See “Static Precautions” on page 2-11.

2. Remove wire from terminal at DIRA-1.
3. Connect an ammeter in series with DIRA as follows:
 - a. Positive (+) to DIRA-1 terminal
 - b. Negative (-) to wire removed from DIRA-1

Run Test

DIRA Solenoid	Ammeter Reading		Operator Display
	Series EZ-B DZ-B	Other Series	
Energized	1.25 to 1.75 amp	0.5 to 1.0 amp	On
De-energized	0.0 to 0.02 amp	0.0 to 0.02 amp	Off

If you do not observe these results, then the test is a failure. reconnect wire at DIRA-1. Perform diagnosis.

Diagnosis and Repair

1. There may be an open or short in DIRA’s coil or associated wiring. Check as follows:
 - a. Turn the key switch OFF and disconnect the battery connector.
 - b. Disconnect JPS10 from the System Card.
 - c. Using an ohmmeter, measure across harness between JS10-7 and JS10-3.
 - d. If resistance is less than 10 ohms or more than 75 ohms, then there is a problem in the DIRA coil circuit. Troubleshoot the solenoid coil and associated wiring.
 - e. Reconnect JPS10.
 - f. Reconnect the battery connector and turn the key switch ON.
2. Connect positive (+) meter lead to JS11-5. Connect negative (-) meter lead to PS3-2. Run Test O04. You should see:

Test Status	Voltage
OFF	less than 0.5 volts
ON	greater than 6.0 volts

If test fails, replace the System Card, VFC, and firmware. Refer to replacement procedures on [page 7-172](#), [page 7-175](#), and [page 7-116](#). Run Configure Mode, then Learn Mode. Re-run the test.

3. Connect positive (+) meter lead to JS11-10. Connect negative (-) meter lead to PS3-2. Step on deadman pedal. Meter reading should be battery voltage. If test fails, [the System Card may be malfunctioning](#). [Replace the System Card. Refer to “System Card” on page 7-172 for replacement procedure. Run Configure Mode, then Learn Mode. Re-run the test.](#)



Digital Output Tests

Test O09 - Toggle Equalizing (EQ) Solenoid

Test O09 - Toggle Equalizing (EQ) Solenoid

Using this test, the equalizing solenoid (EQ) can be turned off and on, verifying its correct operation.

A successful test proves that the wiring and related circuitry in the VFC, System Card, and EQ coil driver are all functioning correctly. It also proves that the EQ solenoid coil and its harness are electrically functional.

It does not prove that the EQ solenoid itself is mechanically functional.

Preparation

1. Turn the key switch OFF and disconnect the battery connector.

▲ CAUTION

Be sure to observe proper precautions against electrostatic discharge. See "Static Precautions" on page 2-11.

2. Disconnect wire at EQ-1.
3. Connect an ammeter in series with EQ solenoid as follows:
 - a. Positive (+) to terminal of EQ-1
 - b. Negative (-) to wire removed from EQ-1

NOTE: For information on how to use maintenance mode, see "Using Maintenance Mode" on page 6-14.

Run Test

EQ Solenoid	Ammeter Reading		Operator Display
	Series EZ-B DZ-B	Other Series	
Energized	1.25 to 1.75 amp	0.5 to 1.0 amp	On
De-energized	0.0 to 0.02 amp	0.0 to 0.02 amp	Off

If you do not observe these results, then the test is a failure. Turn off power and reconnect wire to EQ-1. Perform diagnosis.

Diagnosis and Repair

1. There may be an open or short in the EQ solenoid's coil or associated wiring. Check as follows:
 - a. Turn the key switch OFF and disconnect the battery connector.
 - b. Disconnect JPS10 from the System Card.
 - c. Using an ohmmeter, measure across harness between JS10-7 and JS10-9.
 - d. If resistance is less than 10 ohms or more than 75 ohms, then there is a problem in the EQ solenoid's coil circuit. Troubleshoot the solenoid coil and associated wiring.
 - e. Reconnect JPS10.
2. Connect positive (+) meter lead to JS11-3. Connect negative (-) meter lead to PS3-2. Run Test O09. You should see:

Test Status	Voltage
OFF	less than 0.5 volts
ON	greater than 6.0 volts



Digital Output Tests

Test O14 - Armature PWM (v.4.5)

Test O14 - Armature PWM (v.4.5)

Using this test, proper operation of the armature PWM (Pulse Width Modulation) to the Power Card and the Main Transistor (Q1) can be verified.

A successful test proves that the wiring, Q1, and related circuitry in the VFC, Power Card, and System Card are all functioning properly.

Firmware version 4.5 and above

In this test, the technician controls the ramp signal to the Power Card. The Operator Display will display the percentage on (from 0 to 30%) and then the current through the armature.

The armature enable signal is also activated during this test, so that the Power Card can pulse the base of Q1.

Preparation

⚠ WARNING

Use extreme care whenever the lift truck is jacked up. Never block the lift truck between the telescopic and the floor. Use a suitable hoist to stabilize the mast. Keep hands and feet clear from vehicle while jacking the lift truck. After the lift truck is jacked, place solid blocks or jack stands beneath it to support it. DO NOT rely on the jack alone to support the lift truck. See "Jacking Safety" on page 2-13.

⚠ CAUTION

During this test, the field is not powered up, so the lift truck should not move. If, however, there is a fault in the traction motor circuit, the traction motor may start. To guard against unexpected movement of the lift truck, elevate the drive tire off the floor before entering this test.

Elevate the drive tire off the floor. See WARNING above.

NOTE: For information on how to use maintenance mode, see "Using Maintenance Mode" on page 6-14.

Run Test

⚠ CAUTION

Do not run this test for an extended period of time as it may damage Q1 and/or the Power Card due to overheating.

⚠ CAUTION

Be sure to observe proper precautions against electrostatic discharge. See "Static Precautions" on page 2-11.

1. Connect a voltmeter positive (+) lead to Q1-C and negative (-) lead to Q1-E.
2. To start ramping Q1 on, press the tilt forward button with this test selected. The test will ramp in 1% increments each time the forward tilt button is pressed, starting at 0% and going to 30%. The Operator Display will show the percentage on, then the current through the armature circuit.
3. To stop the test at any time, press the tilt back button once.



Digital Output Tests

Test O17 - Field PWM Ramp (v.3.6)

ramp from 0.0 to Negative Battery Voltage (approximately). It will repeat this ramp constantly until test is stopped.

If you do not observe these results, the test is a failure. Perform diagnosis.

Diagnosis and Repair Firmware version 3.6**▲ CAUTION**

Be sure to observe proper precautions against electrostatic discharge. See "Static Precautions" on page 2-11.

1. Turn the key switch OFF and disconnect the battery connector.
2. Test TM1 and TM2. See "Field Transistors TM1/TM2" on page 7-182.
3. Check drive motor cables for continuity. Connect ohmmeter leads between PRS1 and PRS2 (with cables attached to field windings). If resistance is more than 2 ohms, troubleshoot the cables and field winding and repair accordingly.
4. Connect the digital voltmeter positive (+) lead to JPS5-8 and the negative (-) lead to JPS3-2. Compare meter readings with the Operator Display.
5. Re-run Test O17.

Operator Display	Voltmeter Reading
Off	less than 1.0 volt
Ramp	0.0 to 12 volts

NOTE: At initial start, 12 volts will display on DMM then drop to less than 1.0 volt each subsequent test. Off will display less than 1.0 volt.

- a. If test passes, go to Test O15 and O16. If Tests O15 and O16 pass, and TM1 and TM2 are good, replace the Power Card.
- b. If test fails, continue with next step.

6. The System Card may be malfunctioning. Replace the System Card. Refer to "System Card" on page 7-172 for replacement procedure. Run Configure Mode, then Learn Mode. Re-run the test.
7. The VFC may be malfunctioning. Replace the VFC and firmware. Refer to "VFC Card" on page 7-175 for replacement procedure. Run Configure Mode, then Learn Mode. Re-run the test.

NOTE: For instructions on selecting Modes of Operation, see "Modes of Operation" on page 6-5.

Component Locator Photos

Component Locator Photos

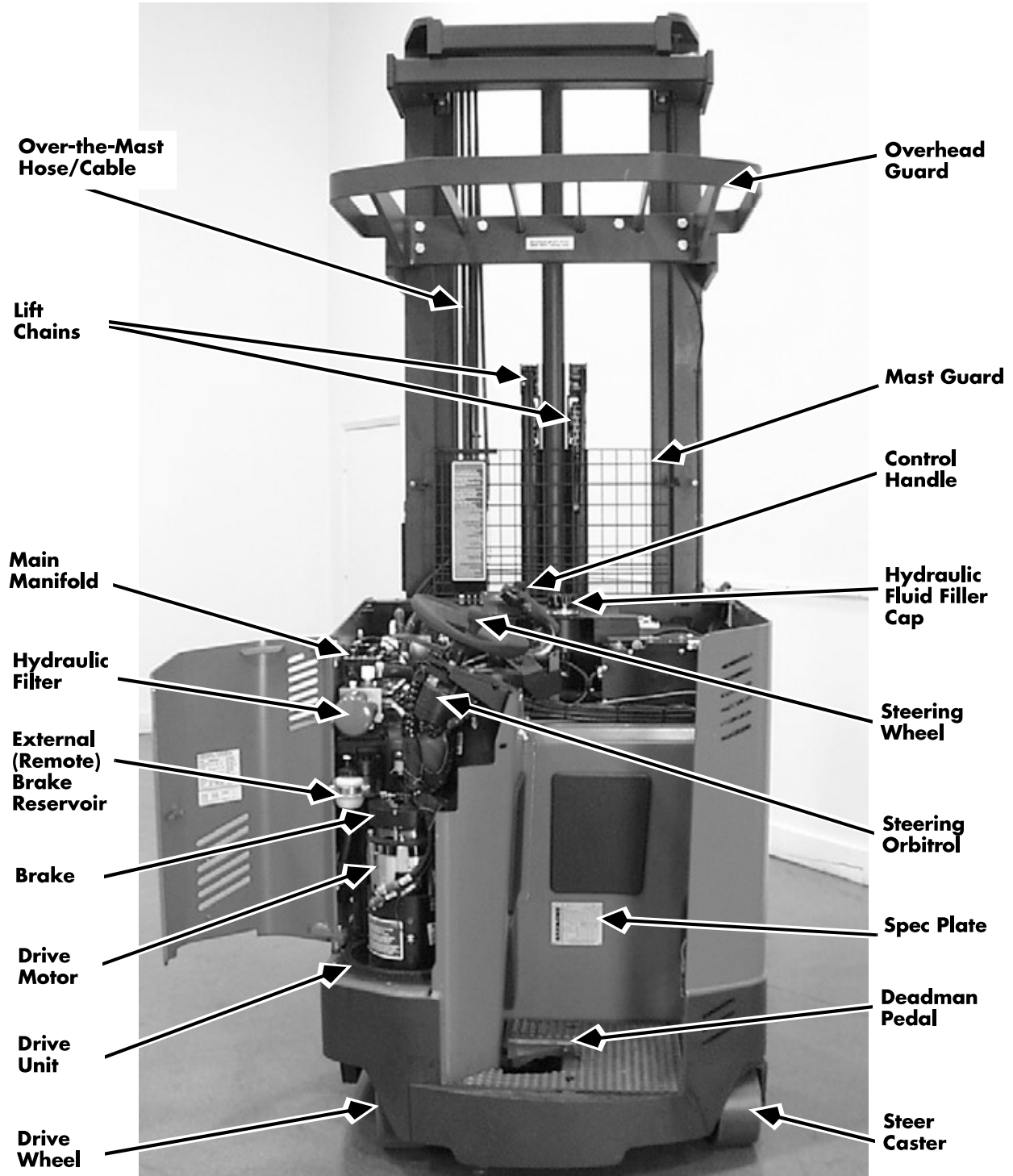

Figure 7-1: Tractor, Series DZ-B

OD/SMARTi® Cover

Series EZ, ES, ET, EF

Removal

1. The right side and top covers must be removed before the OD/SMARTi® cover can be removed.
See “Right Side Cover” on page 7-12.
See “Top Cover” on page 7-13.
2. Remove the SMARTi® module, if so equipped. See “SMARTi® Module” on page 7-184.
3. Remove the two (2) nuts and washers at the top and left side of the Operator Display.
4. Loosen the screw in the lower right corner of the cover, near the control handle pivot.
5. Loosen the Allen head setscrew in the control handle pivot.
6. Remove the control handle from the pivot.
7. Carefully lift the OD/SMARTi cover off, taking care not to disturb the wiring for the key switch, Operator Display, and cold storage warning LEDs (if so equipped).

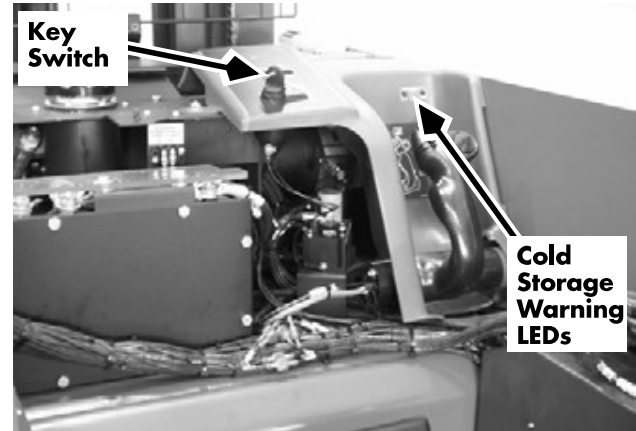

Figure 7-11: OD/SMARTi® Cover, Series EZ-B

Installation

1. Place the cover in position on the lift truck.
2. Install the control handle on the pivot.
3. Apply thread-locking compound (P/N 990-536) to the control handle Allen head setscrew. Install the setscrew and tighten.
4. Tighten the screw in the lower right corner of the cover.
5. Reinstall the two (2) washers and mounting nuts at the top and left side of the Operator Display.
6. Reinstall the top cover and right side cover.

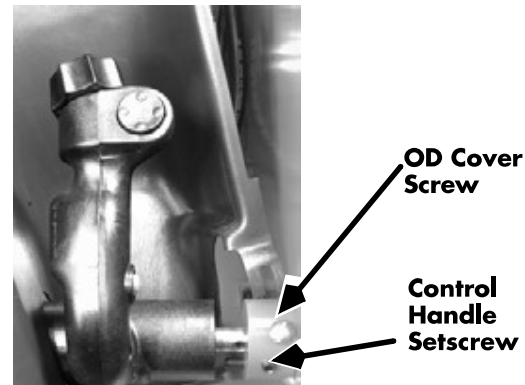

Figure 7-12: Control Handle and OD Cover

Steering Orbitrol

▲ CAUTION

On Series EZ-B/DZ-B, the steering electric motor runs, even with the deadman pedal released, if either lift motor or drive motor temperature exceeds 160°F (71°C).

▲ CAUTION

Turn the key switch OFF and disconnect the battery connector before working on the steering orbitrol.

Removal

1. Turn the key switch OFF and disconnect the battery connector.
2. Remove the top cover. Open the drive motor compartment door.
3. Remove the steering wheel. See “Steering Wheel and Knob” on page 7-24.
4. Mark, remove, and cap the hydraulic hoses from the orbitrol.
5. Remove the four (4) mounting bolts securing the orbitrol to the tractor bracket. Note the presence of alignment shims, if used. See Figure 7-20.
6. Remove the fittings from the orbitrol body, carefully noting their angles for later installation.

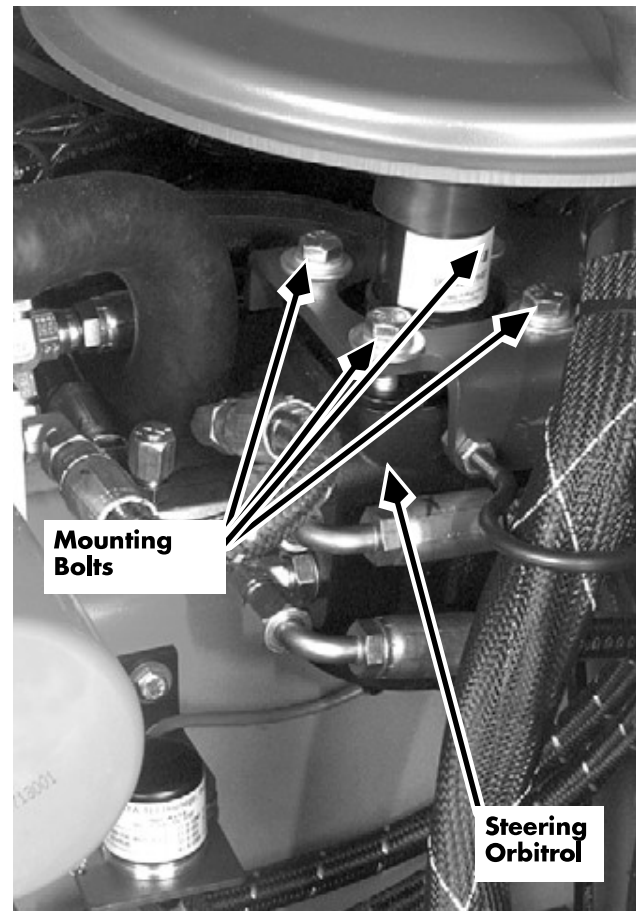

Figure 7-20: Steering Orbitrol (Series EZ-B shown)



Caster Assembly

Removal

1. Turn the key switch OFF and disconnect the battery connector.

⚠ WARNING

Use extreme care whenever the lift truck is jacked up. Never block the lift truck between the telescopic and the floor. Use a suitable hoist to stabilize the mast. Keep hands and feet clear from vehicle while jacking the lift truck. After the lift truck is jacked, place solid blocks or jack stands beneath it to support it. DO NOT rely on the jack alone to support the lift truck. See “Jacking Safety” on page 2-13.

2. Jack and block the tractor end behind the caster, clear of the counterweight.
3. Disconnect the steering linkage arm at the caster housing, if equipped with steerable caster. Reference “Steering Linkage” on page 7-41. Reference “Underside Components” on page 7-10.
4. Measure the fore/aft play in the A-frame pivot and note the amount for reference during reinstallation.
5. Detach the inertial dampener, if so equipped, from the A-frame. See “Inertial Dampener” on page 7-106.
6. Remove the down travel stop bolt and washer.
7. Remove the caster springs and adjusters.
8. Remove the counterweight. The rear A-frame pivot pin is now exposed.
9. Remove the rear A-frame pivot pin, noting the location and quantity of spacers.
10. Support the A-frame.

Steering and Controls

Disassembly

2. Remove the two (2) screws holding the plastic cable retainer (may not be present on some handles).
3. Remove the control handle retaining ring located below the lift/lower potentiometer VR2.

NOTE: The retaining ring is under tension. Use care when removing. Place the tip of a flathead screwdriver at the tilt/sideshift side of the ring and peel it out. Then remove it with pliers. [See Figure 7-38.](#)

4. Remove four (4) Allen head screws securing the handle shell halves together.
5. Separate handle shell halves slightly. Slide the cable retainer out of the slot. It may be necessary to insert a thin-bladed screwdriver at the end of the retainer and tap to loosen the retainer. [See Figure 7-37.](#)
6. If using fixture (P/N 828-009-213), place the two dowel pins (P/N 812-403) in the outer pin holes of the fixture. Position the handle hole to allow the thumb screw (P/N 714-168) to engage the mounting hole in the shaft, then tighten the thumb screw.
7. Hold the tilt/sideshift button to prevent it from springing out. Carefully remove the left half of the handle shell.
8. Remove the tilt/sideshift button, spring, and spring base plate. [See Figure 7-39.](#)



Figure 7-38: Control Handle Retaining Ring Removal (EZ/ES/ET/EF)

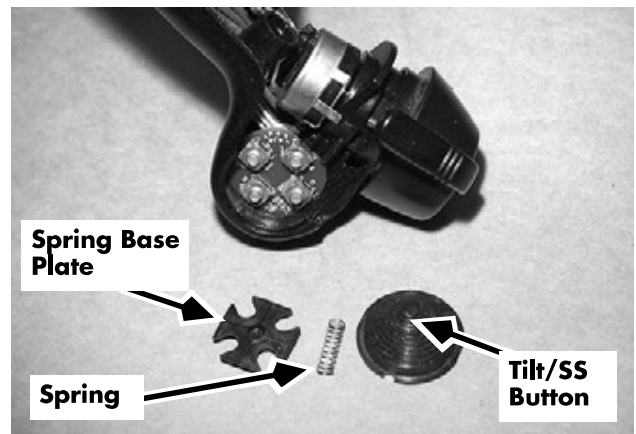

Figure 7-39: Control Handle, Right Half (EZ Cold Storage shown)

Horn Switch (S3)

Removal/Installation procedure is similar to that for “Reach/Retract Switches” below.

Reach/Retract Switches (S4/S5)

NOTE: Because of the delicate ribbon heater, heated handle P/N 828-006-935 is not field repairable; entire control handle replacement is required.

NOTE: Because of the ESD sensitivity of solid state potentiometers, handle P/N 828-009-630 is not field repairable; entire control handle replacement is required.

Removal

1. Remove and disassemble the control handle. See “Control Handle Shell” on page 7-44.
2. Note the flat on the switch body, which is oriented towards the lift/lower potentiometer.

▲ CAUTION

See “Soldering Procedures” on page 7-120.

3. Remove the switch and unsolder the wires.

Installation

1. Orient the new switch with the flat toward the lift/lower potentiometer.
2. Solder the wires to the new switch.
3. Insert the switch into the handle shell.
4. Reassemble and reinstall the control handle. See “Control Handle Shell” on page 7-44.
5. Reconnect the battery connector and turn the key switch ON.
6. If the horn does not sound during SelfTest, enter Maintenance Mode. Run Test O18 - Toggle Horn (Page 6-160).

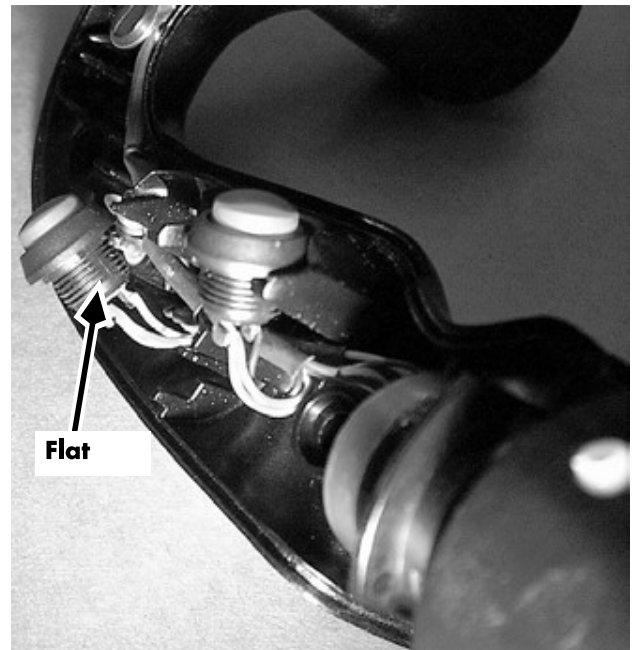

Figure 7-49: Horn and Reach/Retract Switches (EZ/ES/ET/EF)



Steering and Controls

Tilt/Sideshift Switch Card (S6-S9)

7. Reassemble and reinstall the control handle. See [“Control Handle Shell” on page 7-57](#).
8. Reconnect the battery connector and turn the key switch ON.
9. Enter Maintenance Mode. Run [Test A05 - Lift/Lower Potentiometer Voltage \(Page 6-78\)](#). Verify voltages. Adjust the potentiometer as described in Test A05 (all except DS/DT).
10. Enter Learn Mode. Run Learn Controls. See [“Using Learn Mode” on page 6-13](#).
11. In Run Mode, test the lift/lower function for proper operation.

Tilt/Sideshift Switch Card (S6-S9)

NOTE: Because of the ESD sensitivity of solid state potentiometers, handle P/N 828-006-161 is not field repairable; entire control handle replacement is required.

NOTE: On the non-cold storage handle P/N 223-000-744, the tilt/sideshift switch card is soldered directly to the cable harness. The switch card can be replaced by soldering the harness wires on the new card, but this is not recommended; entire control handle replacement is recommended.

Consult the parts matrix table in the Parts Catalog to determine the proper part numbers for replacement.



Drive and Brake

Drive and Brake



Drive and Brake

Installation

4. Install the encoder timing belt between the encoder pulley and the pulley on top of the drive motor. Ensure the tension spring is properly installed to place tension on the timing belt.

NOTE: Ensure the timing belt has the correct number of teeth for the pulleys in use.

5. Route the encoder harness across the lift truck console to the system card.
6. Connect the encoder cable to the system card at JPS15.
7. Fit the encoder harness into the cable bundle and install tie wraps where previously removed.
8. Reinstall the top and right side covers.
9. Close the drive motor compartment door.
10. Reconnect the battery connector and turn the key switch ON.
11. Test drive the lift truck to verify proper operation.



Drive and Brake

Installation

tap it with a steel hammer to make sure that the rotor is seated on the snap ring.

- b. Connect the brake line. Bleed the air from the brake lines by stepping on the deadman pedal several times.
- c. With the deadman pedal depressed, measure the gap between the brake rotor and the bottom plate, and between the brake rotor and the top plate.
- d. When the deadman pedal is depressed, the gap between the bottom of the brake rotor and the brake pad should be between 0.005 and 0.008 in. (0.13 and 0.20 mm). The gap between the top of the brake rotor and the brake pad will vary, but it should not be less than 0.010-inch (0.25 mm).

NOTE: Proper master cylinder operation will enable 0.030 to 0.035 in. (0.762 to 0.889 mm) of total brake rotor/pad gap. If not, recheck pedal height and, if necessary, bleed the brake system.

- e. Add or remove shim washers until the proper gap is achieved.
4. Go to step 6.
 5. If not using brake adjustment tool P/N 828-003-804, go to step 3.
 - a. Place the tool (P/N 828-003-804) on the motor shaft, large disk down.
 - b. Measure the gap between the tool and the motor end bell.
 - c. The air gap should be between 0.005 and 0.008 in. (0.13 and 0.20 mm) between the bottom of the tool and the top of the end bell.
 - d. Add or remove shim washers until the proper gap is achieved.
 - e. Remove the tool.
 6. Install the Woodruff key on the motor shaft. Clean the shaft area where the rotor is installed on it. Apply thread-locking primer (P/N 990-533) to this area. Use thread-locking compound (P/N 990-536) sparingly to secure the rotor to the shaft.



bolts, install, and tighten.

9. Measure the distance from the top of the deadman pedal to the floor of the operator compartment. If the dimension does not match the table below, inspect the pedal and linkage for deformation or damage and replace as needed.

Series ES/ET/EZ/EF	Series DS/DT/DZ
3.5 inches (89 mm)	3.0 to 3.25 inches (76 to 82.5 mm)

10. If the lift truck is equipped with an external brake fluid reservoir, reconnect the supply hose to the reservoir with a hose clamp. Mount the reservoir to the frame.
11. Install a tie wrap to secure the supply hose to the ventilation slots near the operator's left leg.
12. **Series EZ/ES/ET/EF only:**
 - a. Install the deadman switch bracket. Adjust the deadman switch. Check the deadman switch for proper operation.
13. Fill the brake fluid reservoir to the fill line. Use only DOT-5 brake fluid (P/N 990-625).
14. Bleed the brake system. [See "Bleeding Brake" on page 7-92.](#)
15. Check that with a fully depressed deadman pedal, there is a total brake/rotor pad gap of 0.030 to 0.035 inch (0.76 to 0.90 mm). If not, repeat the procedure for bleeding air from the brake system.
16. Reconnect the battery connector and turn the key switch ON. Close the drive motor compartment door.
17. In an open area free of obstructions and hazards, carefully test the brake and deadman switch for proper operation.
18. Turn the key switch OFF and disconnect the battery connector.
19. Open the drive motor compartment door. Install the master cylinder access plate and tighten the mounting nut on the stud.
20. Close the drive motor compartment door.



Electrical Components

Battery State-of-Charge

The following example describes installing a new battery when the Operator Display does not reset. Assume the following:

- BSOC configured at 95%, the battery connected is at 45% charge, and the new battery is at 92% charge.

Since the new battery charge has not changed by at least 50% and the state-of-charge of the new battery is not greater than the BSOC reset configured value, the Operator Display continues to show the old battery's charge of 45% (even though the new battery is at 92%). What occurs is that the Operator Display remains at 45% until the charge of the new battery declines to 45%. Then the display resumes its normal descent.

One final example. Assume the following:

- BSOC configured at 95%, the battery connected is at 65% charge, and the new battery is at 20% charge.

Again, the change in charge is not at least 50% and the new battery is not above the configured BSOC level. The Operator Display continues to show 65%, but then descends rapidly as the lift truck operates until the Operator Display shows the original charge of 20%. Once the display shows 20%, it resumes a normal descent.



Electrical Components

Inspection

Motor	Raymond P/N	Manufacturer P/N	Brush Length				Brush Spring Tension			
			Minimum		Maximum		New		Worn	
			in.	mm	in.	mm	oz.	gr	oz.	gr
Aux	570-278/501 579-279		0.62	16	1.30	35	65	1820	40	1120
	570-287/501 579-287		0.62	16	1.30	35	65	1820	40	1120
	570-294/501		0.62	16	1.30	35	65	1820	40	1120
	570-354/501 579-354		0.62	16	1.30	35	65	1820	40	1120
	570-358/451									
	570-359/501 579-359		0.62	16	1.30	35	65	1820	40	1120
Steer	570-363/451									

- Repeat steps 3 through 9 for the remaining brushes.

CLICK HERE TO **DOWNLOAD** THE COMPLETE MANUAL

- Thank you very much for reading the preview of the manual.
- You can download the complete manual from: www.heydownloads.com by clicking the link below



- Please note: If there is no response to CLICKING the link, please download this PDF first and then click on it.

CLICK HERE TO **DOWNLOAD** THE COMPLETE MANUAL



Electrical Components

Installation

5. Apply thread-locking compound (P/N 990-536) to the threads of the lift pump mounting bolts. Mate the lift pump spline to the lift motor and attach the lift pump to the lift motor with the two mounting bolts. Tighten and torque to 20 ft. lbs. (27 Nm).
6. Prior to tightening the motor mounting bolts, close the drive compartment door to ensure a good fit with the lift motor fan housing (if so equipped). Reposition motor as needed.
7. Tighten and torque the motor mounting bolts. See Appendix.
8. Attach the power cables to the lift motor, observing proper polarity. Use a second wrench on the stud terminal securing nut to avoid twisting the stud. Torque the motor cable securing nuts to 100-120 in. lbs. (11.2-13.6 Nm).
9. If so equipped, apply heatsink compound (P/N 990-508) to the threads of the lift motor temperature sensor. Thread the sensor all the way into the lift motor and tighten the retaining nut. Connect the sensor connector JPZ.

NOTE: If cold storage-equipped, apply silicone sealing compound (P/N 990-445) to the connector and socket before connecting.

10. Reconnect the battery connector and turn the key switch ON.
11. Test the lift functions. Check for fluid leaks.
12. **Series DS/DT/DZ-A:** Attach the cover mounting bracket to the orbitrol.
Series ES/ET/EZ-A/EF: Attach the steering wheel cover.
13. Reinstall covers previously removed.

Contactors

Contactor Removal

1. Turn the key switch OFF and disconnect the battery connector.
2. Remove the right side cover. See “Right Side Cover” on page 7-12. For Series EZ-B/DZ-B, remove the top cover. See “Top Cover” on page 7-13.
3. If cold storage-equipped, remove contactor/fuse compartment cover.
4. Note the location of cables and wires attached to the contactor terminals. Label as needed for proper reconnection.
5. Disconnect wires, power cables, fuses, and bus bars attached to the contactor lugs.
6. Remove the two hex nuts holding the contactor to the mounting panel.
7. Remove the contactor from the mounting studs carefully, as the coil wires are still attached.
8. Remove contactor coil wires by pulling the wire connector. Note their locations and label if necessary.

Contactor Installation

1. Attach the coil wires by sliding the connector onto the appropriate spade terminal.
2. Position the contactor on the threaded studs of the mounting panel. Attach with hex nuts.
3. Install all bus bars, fuses, power cables, and wires previously removed. Tighten lugs securely. When connecting to fuses, locate small wire terminals under larger wire terminals and bus bars. Attach the fuses on top of all other connectors.
4. If cold storage-equipped, reinstall the contactor/fuse compartment cover.
5. Install the right side cover. For Series EZ-B/DZ-B, install the top cover. See “Top Cover” on page 7-13.
6. Reconnect the battery connector and turn the key switch ON.
7. Test the operation of the lift truck.

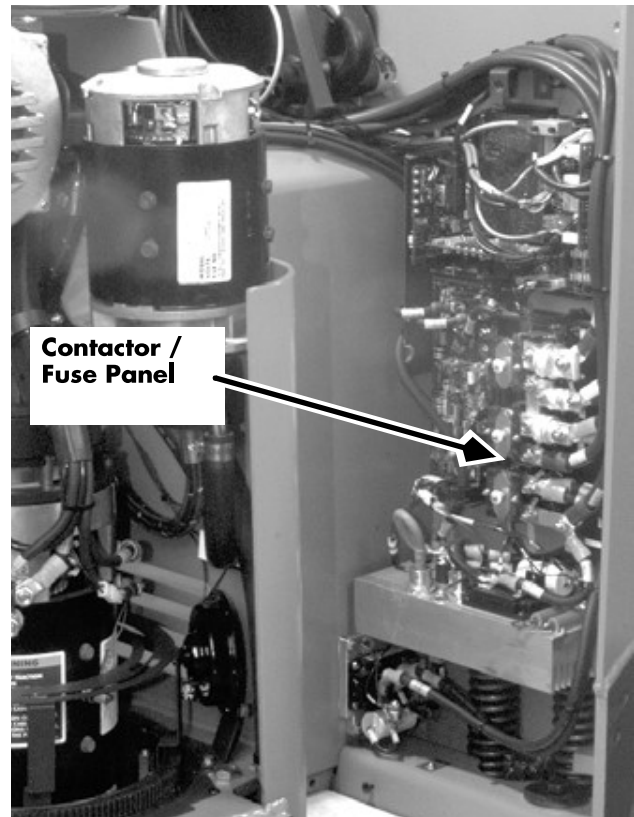

Figure 7-122: Contactor location, 3-motor, non-cold storage

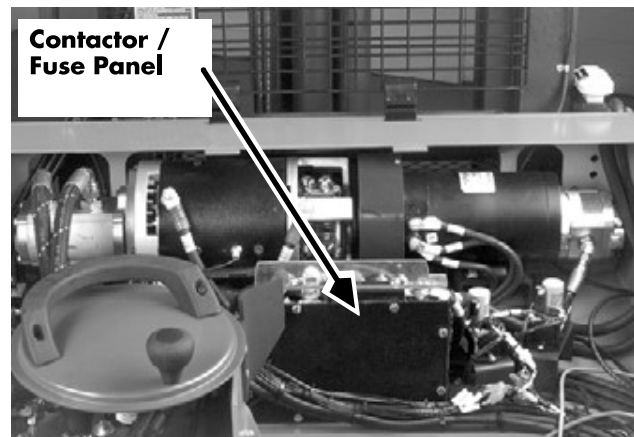

Figure 7-123: Contactor location, 4-motor, cold storage

Horn Components

Horn and Suppressor Removal

1. Turn the key switch OFF and disconnect the battery connector.
2. Open the drive motor compartment door.
3. To remove the horn suppressor module:
 - a. Disconnect the horn suppressor electrical connector HSUP at the suppressor.
 - b. Electronic horn: Remove the machine screw securing the module to the bracket.
 - c. Mechanical horn: Remove the suppressor from the lift truck frame.
4. To remove the horn:
 - a. Disconnect the horn wires from terminals H1 and H2 in the horn harness.
 - b. Remove the mounting bolt, lock washer, and washer securing the horn bracket to the tractor.
 - c. On mechanical horns, remove the wires from the horn terminals, noting and labeling the polarity to ensure correct reconnection.

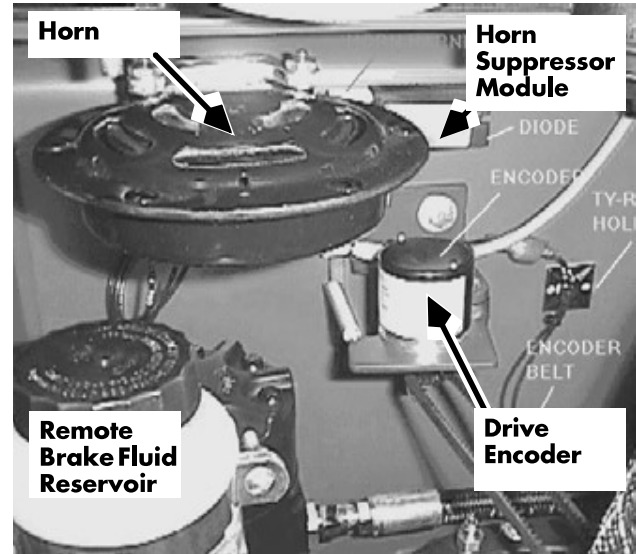

Figure 7-137: Mechanical Horn and Suppressor, Series ET

Horn and Suppressor Installation

1. To install the horn:
 - a. **On electric horns, remove the grounding clip from the new horn, if present.**
 - b. Install the horn assembly on the tractor with the mounting bolt, lock washer and was her.
 - c. On mechanical horns, connect harness wires to the horn terminals, observing proper polarity.
 - d. Connect horn harness connectors H1 and H2.
2. To install the horn suppressor module:
 - a. Electronic horn: Mount the horn suppressor module to the mounting bracket with the machine screw.

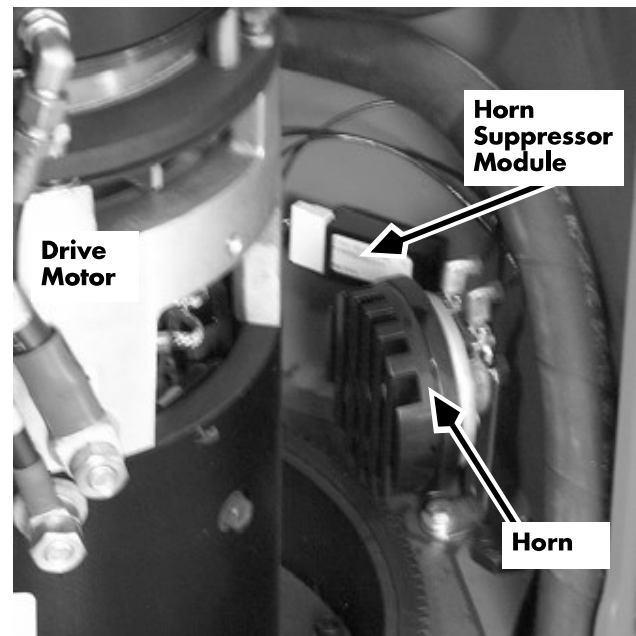

Figure 7-138: Mechanical Horn and Suppressor, Series DZ



Positive Lead	Negative Lead	Meter Reading
Collector (Base Plate)	E (Emitter)	Open
E (Emitter)	Collector (Base Plate)	Less than 1.0 ohm
E (Emitter)	B (Base)	Less than 1.0 ohm
Collector (Base Plate)	B (Base)	Open
B (Base)	E (Emitter)	Less than 1.0 ohm
B (Base)	Collector (Base Plate)	Less than 1.0 ohm

5. Perform installation steps 3 through 7.

VFC Card

Removal

1. Turn the key switch OFF and disconnect the battery connector.
2. Remove the right side cover. See “Right Side Cover” on page 7-12.

▲ CAUTION

Use the proper precautions against electrostatic discharge. See “Static Precautions” on page 2-11.

3. If cold storage-equipped, remove the electronics compartment cover. See “Electronics Compartment Cover” on page 7-17.
4. If regen equipped, disconnect connector JPC2 at the power card. **Failure to disconnect regen could lead to damage to the regen circuit when the lift truck is restarted.**
5. Remove the four (4) screws securing the VFC card to the system card.
6. Carefully lift the VFC card from the connectors JS1 and JS2.
7. Remove the new VFC card from the anti-static bag and place the old card in the bag.

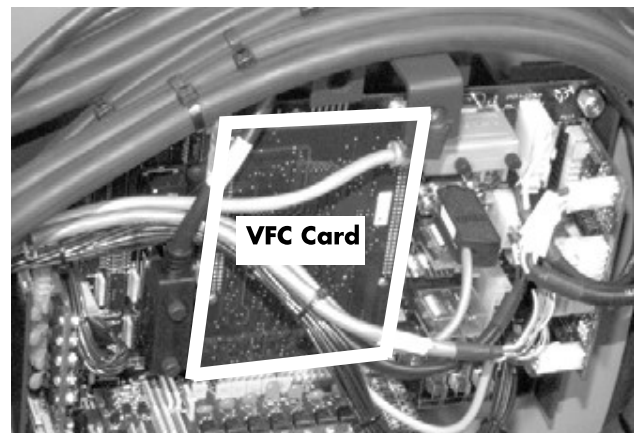

Figure 7-153: VFC Card Location on System Card

Line Filter

Removal

1. Turn the key switch OFF and disconnect the battery connector.
2. Remove the right side cover. See “Right Side Cover” on page 7-12.
3. Remove the top cover. See “Top Cover” on page 7-13.
4. For series DS/DT/DZ, skip to step 7.
5. Remove the SMARTi[®] module, if so equipped. See “SMARTi[®] Module” on page 7-184.
6. Remove the OD/SMARTi cover. See “OD/SMARTi[®] Cover” on page 7-15.
7. Remove the line filter bracket mounting nuts. Lift the filter and bracket assembly off the studs on the deck.
8. Remove the wires from the line filter assembly, labeling as needed to ensure proper reconnection later.
9. Remove the line filter assembly from the bracket.

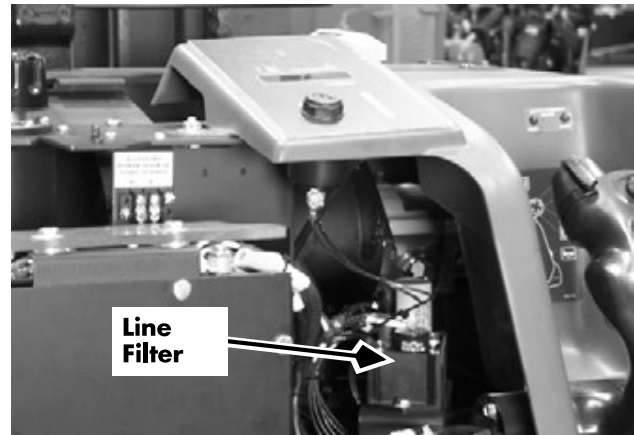

Figure 7-161: Line Filter, Series EZ-B

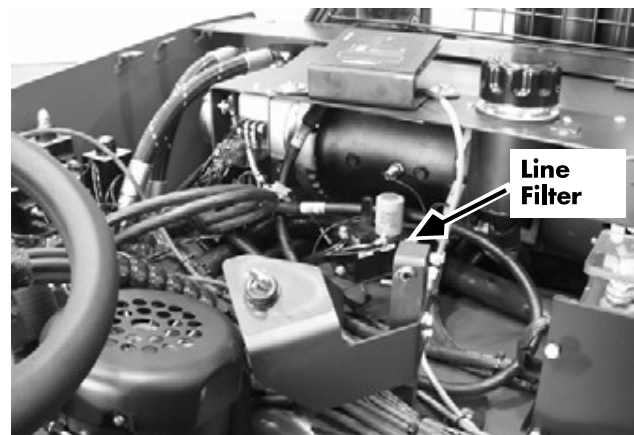

Figure 7-162: Line Filter, Series DZ-B

Installation

1. Attach the wires to the respective terminals of the line filter assembly and tighten terminals.
2. Attach the line filter assembly to the filter bracket.
3. Place the line filter and bracket assembly over the mounting studs on the deck.
4. Secure the filter bracket to the deck with mounting nuts and tighten.
5. For series DS/DT/DZ, skip to step 8.
6. Reinstall the OD/SMARTi cover.
7. Reinstall the SMARTi module, if previously removed.
8. Reinstall the top cover.
9. Reinstall the right side cover.



Hydraulic Components

Refilling the System

11. Direct the hydraulic filter drain hose into the waste container. Remove the hydraulic filter.
12. If it is necessary to flush the reservoir, remove the reservoir.
13. Dispose of the old hydraulic fluid following all local regulations.

Refilling the System

1. If the reservoir was removed for flushing, install the reservoir.
2. Remove the gasket on the new hydraulic filter and coat both sides with hydraulic fluid. Replace the gasket on the filter.
3. Thread the filter onto the filter adapter until the gasket contacts the seat. Turn three-quarters of a turn to tighten. Use hand pressure only.
4. Connect the auxiliary motor pressure line at the manifold.
5. Fill the hydraulic reservoir:
 - On trucks with 9-inch (23 cm) wide mast uprights, the reservoir holds 8.8 gallons (33.3 liters) of fluid.
 - On trucks with 8-inch (20 cm) wide or less mast uprights, the reservoir holds 5.8 gallons (22.1 liters) of fluid.
 - Fill the reservoir until only a small bubble remains visible in the reservoir sight glass. **Do not overfill the reservoir.**
 - Use only recommended hydraulic fluid. See “[Lubrication Specification Chart](#)” on [page 2-2](#) for approved fluids.
6. Reconnect the battery connector and turn the key switch ON.
7. Bleed the hydraulic system. See “[Bleeding the System](#)” on [page 7-196](#).
8. Install the tractor top cover and right side cover. Close and secure the drive motor compartment door.

Hydraulic Components

Auxiliary System Pressure Adjustment

5. Remove the cap from the auxiliary pressure adjustment port, located on the auxiliary pump below the suction line.
See Figure 7-184.
6. Reconnect the battery connector and turn the key switch ON.
7. Tilt the carriage all the way back against the stops.
8. While continuing to try tilting the carriage backward, use a screwdriver to turn the auxiliary pressure adjusting screw to obtain a pressure of 1600 p.s.i. (11,030 kiloPascals).
9. Turn the key switch OFF and disconnect the battery connector.
10. Replace the cap on the auxiliary adjusting screw. Remove the pressure gauge from the auxiliary pressure line and replace the cap.
11. Secure the drive motor compartment door,
12. **Series EZ-B/DZ-B:** Install the top and right side covers.

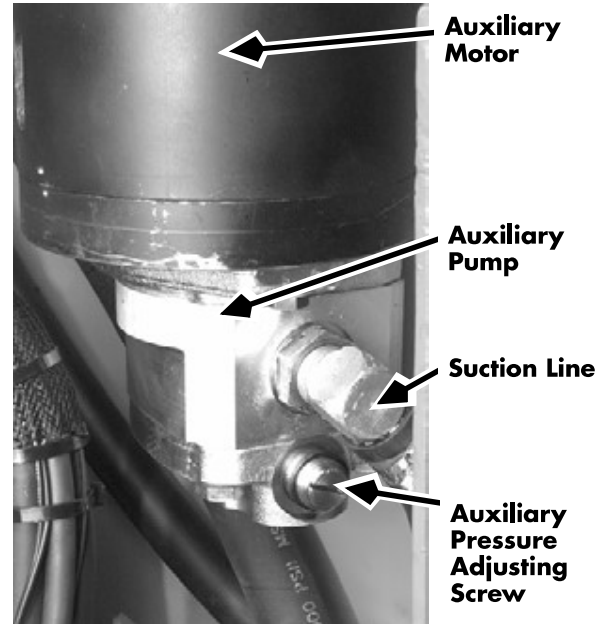

Figure 7-184: Aux Pressure Adjustment Screw, Series EZ-B

▲ CAUTION

The auxiliary motor and steering electric motor will run, even with the deadman pedal released, if either the lift motor or drive motor temperature exceeds 160°F (71°C). Turn the key switch OFF and disconnect the battery connector before working on hydraulic connections.

Removal

1. Turn the key switch OFF and disconnect the battery connector.
2. Remove the right side and top covers. See “Right Side Cover” on page 7-12. See “Top Cover” on page 7-13.
3. If cold storage-equipped, remove the electronics compartment cover. See “Electronics Compartment Cover” on page 7-17.
4. Open the drive motor compartment door.
5. Remove the auxiliary suction line at the hydraulic filter adapter and secure the line in an elevated position.
6. Direct the hydraulic filter drain hose into a waste container and remove the hydraulic filter.

NOTE: Cap all disconnected hydraulic lines to prevent contamination from entering.

7. Remove the two lift pump pressure hoses at the pump. See Figure 7-197 on page 7-216.
8. Remove the lift cylinder supply line at the manifold. See Figure 7-196.
9. Remove the two over-the-mast hoses at the manifold.
10. Remove the auxiliary pressure line at the manifold.
11. Remove the steer return line at the hydraulic filter adapter.

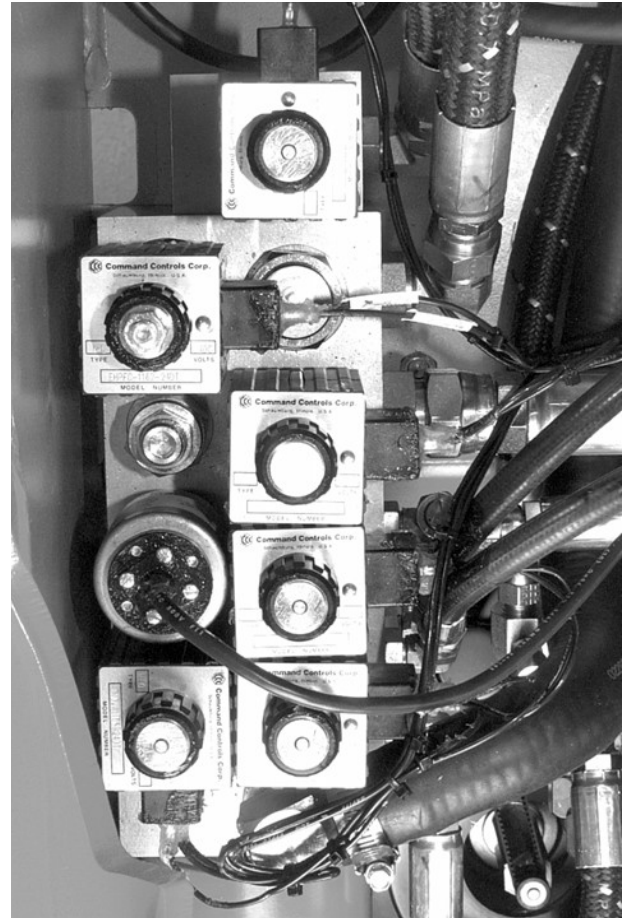

Figure 7-196: Hydraulic Manifold, Series EZ-B (top view, with solenoids)

Solenoid, 4-D Caster Wheel Positioner

The 4-D caster wheel positioner (4-D steer) solenoid is attached to the 4-D manifold located underneath the hydraulic fluid filter.

Removal

1. Raise the forks to lower the hydraulic fluid level in the reservoir below the hydraulic filter.
2. Turn the key switch OFF and disconnect the battery connector.
3. Open the motor compartment door.
4. Remove the top cover. See “Top Cover” on page 7-13.
5. Feed the hydraulic filter drain hose through the front vent into a container.
6. Remove the hydraulic fluid filter.
7. Remove the mounting nuts from the 4-D manifold bracket.
8. Lift the manifold and solenoid off the bolt studs.
9. Remove the nut from the end of the solenoid.
10. Slide the coil off the shaft of the solenoid.
11. Remove the solenoid valve body.

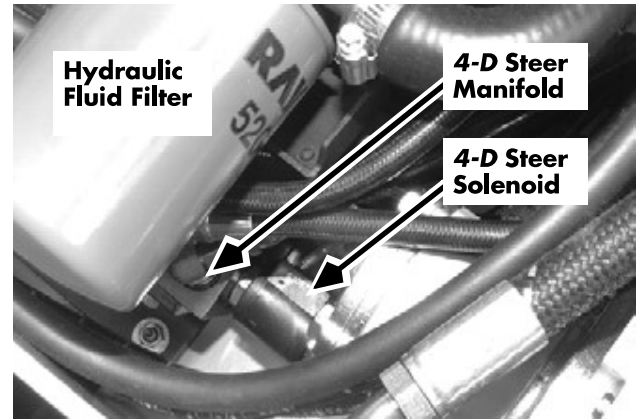
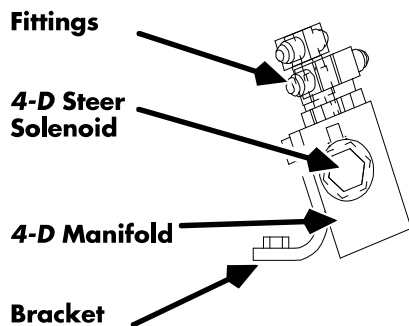

Figure 7-205: 4-D Wheel Positioner Solenoid

END VIEW OF SOLENOID AND MANIFOLD



TOP VIEW OF TRACTOR

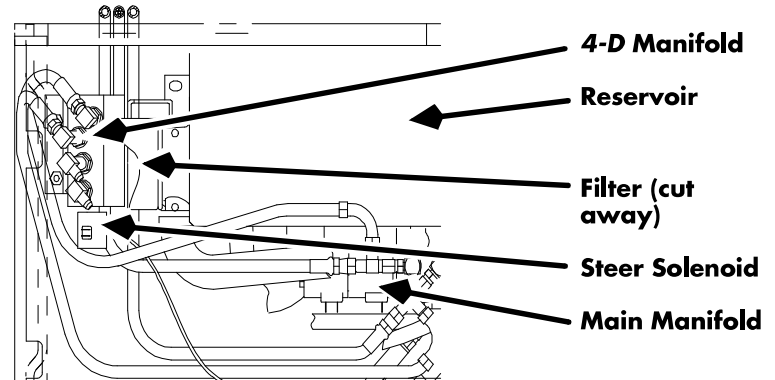

Figure 7-206: 4-D Caster Wheel Positioner Solenoid Location



Lift Cylinder, Front Cluster

NOTE: For illustrations, see “Lift Cylinders” on page 7-229.

Removal

1. Remove the carriage. See “Reach Carriage Assembly” on page 7-291, steps 1-13.
2. Reconnect the battery connector and turn the key switch ON.
3. After removing the carriage, elevate the inner telescopic enough to place support blocks under the inner and outer telescopics. Clamp the support securely in place. Lower the mast onto the support.
4. Lower the telescopic onto the block and relieve pressure by operating the lower control.
5. Turn the key switch OFF and disconnect the battery connector.
6. Have a container available to catch hydraulic fluid when you remove the hydraulic hose. At the back cylinder, remove the hydraulic hose between the back cylinder and the cluster.
7. To prevent the center piston from sliding out of the housing as the cluster is removed, attach a wire around the hydraulic hose fitting and through the cylinder housing weldments.
8. The cluster is held in place by a bolt on top, a nut on the bottom, and two eyes approximately 9 in. (23 cm) from the bottom of the side cylinders. These eyes set in hooks on the inner lower telescopic cross-tie.

Remove the nut at the bottom of the cluster assembly.
9. Remove the bolt, flat washer, and plastic spacer at the top of the cluster assembly. Tilt the top of the cluster forward as far as possible.
10. Attach a hoist strap around the cluster below the chain anchors.
11. Use a hoist to lift the cluster off the hooks on the inner lower telescopic cross-tie.



Hydraulic Components

Lift Cylinder, Back Cylinder, Spiral Ring Retention

14. **Loosen** the top bolt in the cylinder about one turn and tap the mounting bracket up from the bottom to obtain a gap of between 0.03 in. (0.8 mm) and 0.125 in. (3.2 mm) from the top of the cylinder to the bottom of the bracket.

NOTE: If the proper clearance is not attainable, a shim should be added between the slide ring and pivot ring to move the cylinder housing down.

15. Once the proper clearance is obtained, insert washers onto the cylinder bracket mounting bolts and tighten to 75 ft. lbs. (102 Nm). Apply thread-locking compound (P/N 990-536) to the top cylinder bolt and re-torque to 5 to 6 ft. lbs. (6.7 to 8 Nm).
16. Test the lift system for proper operation and remove the blocking.



9. Re-install the cylinder or cylinder cluster.
See [“Lift Cylinder, Back Cylinder, Threaded Anchor Retention”](#) on page 7-236 and/or [“Lift Cylinder, Front Cluster”](#) on page 7-233.

Lift Cylinder Lowering Cushion

NOTE: For illustrations, see [“Lift Cylinders”](#) on page 7-229.

Removal

1. Remove the cylinder or cylinder cluster from the lift truck. See [“Lift Cylinder, Back Cylinder, Threaded Anchor Retention”](#) on page 7-236 and/or [“Lift Cylinder, Front Cluster”](#) on page 7-233.
2. Remove the piston rod from the cylinder. Reference [“Lift Cylinder Front and Back Cylinder Seal Repacking”](#) on page 7-247 or [“Lift Cylinder, Side Cylinder Seal Repacking”](#) on page 7-244.
3. With piston rod removed, secure the piston in a **padded** v-block or vise.

⚠WARNING

When the snap ring is removed, the cushion spring will forcibly eject the cushion from the piston. Keep body away from the piston end and use care so as to avoid violent ejection.

4. Compress the cushion to relieve pressure on the snap ring.

NOTE: A special tool can be formed from round bar stock to fit between the hydraulic fluid port and the compressed cushion.

5. Remove the snap ring from the inside of the cylinder.
6. Release the cushion slowly. The cushion spring will eject the cushion from the piston.
7. Remove the ring retainer and seal from the cushion.

Installation

1. Hold the cylinder in place and bolt the yokes in place.
2. Install the pin through the piston and into the fork tilt mechanism.
3. Install the snap ring onto the pin.
4. Connect the hydraulic hoses. Check the hydraulic fluid level and refill as needed.
5. Remove blocking from the carriage and reach mechanism.
6. Reconnect the battery connector and turn the key switch ON.
7. Test operate the lift truck.
8. Return the lift truck to service.

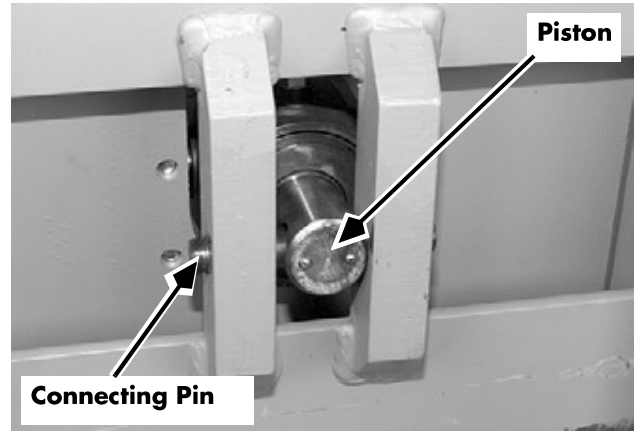

Figure 7-233: Tilt Cylinder Piston and Connecting Pin
(Viewed from Forks)

4-D® Caster Wheel Positioner Cylinder

The 4-D Caster wheel positioner cylinder is located on the underside of the 4-D baseleg. It is actuated by a solenoid valve located under the hydraulic filter in the tractor section.

Removal

1. Position the 4-D caster wheel in the fore-aft position.
2. Turn the key switch OFF and disconnect the battery connector.

⚠ WARNING

Use extreme care whenever the lift truck is jacked up. Never block the lift truck between the telescopic and the floor. Use a suitable hoist to stabilize the mast. Keep hands and feet clear from vehicle while jacking the lift truck. After the lift truck is jacked, place solid blocks or jack stands beneath it to support it. DO NOT rely on the jack alone to support the lift truck. For detailed instructions, see "Jacking Safety" on page 2-13.

3. Jack up the right side of the lift truck.
4. Remove the bolt which secures the wheel positioner cylinder to the caster. Swing the cylinder aside, retaining the washers.
5. If necessary, cut the plastic tie wraps to allow access to hose connections at the cylinder.
6. Position rags to catch hydraulic fluid as hoses are removed. Remove the two hoses from the cylinder and position hoses and cable out of the way.
7. If necessary, turn the hydraulic elbow fitting to gain access to the cylinder body nut.

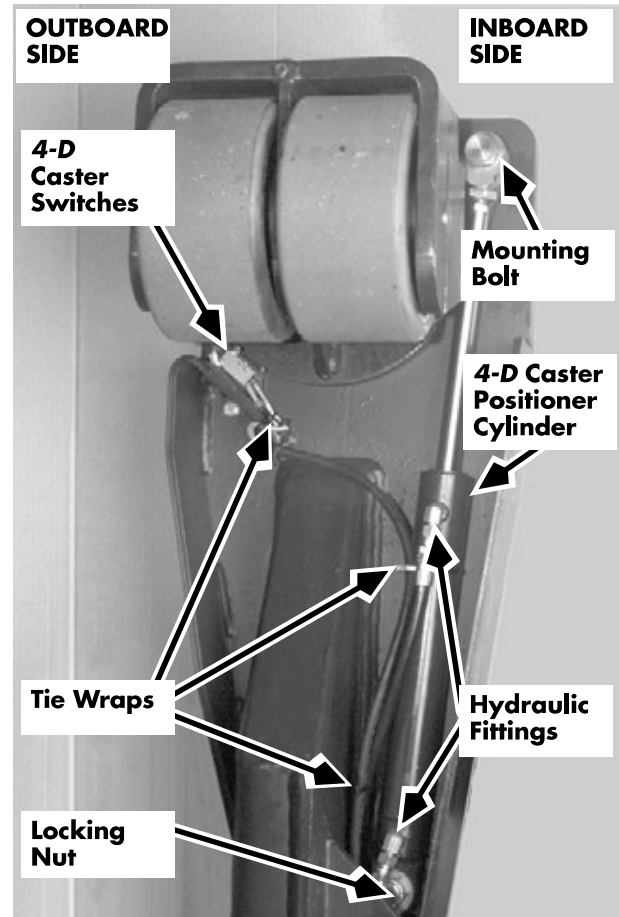

Figure 7-242: 4-D Caster Positioner Cylinder

6. Add required shims equally on either side so that total lateral movement between the telescopics is 0.030 to 0.045 in. (0.76 to 1.14 mm). This may involve a trial and error method.
7. Be sure that the roller bearing mounting screws are clean before you install them.
8. Use thread-locking compound (P/N 990-536) on the screws.
9. Torque the countersunk screw on the outer telescopic to 170 ft. lbs. (230 Nm).
10. Torque the 1 1/8 in. hex head screw on the main mast to 170 ft. lbs. (230 Nm).
11. Reconnect the battery connector and turn the key switch ON.
12. Lift the carriage mast and unblock the mast.
13. Test the operation of the telescopics.
14. Return the truck to service.



Figure 7-250: Upper Mast Bearing, Main Mast

Complete Mast Shimming

Objective of Mast Shimming

The objective of shimming a mast is to ensure a smooth running unit which is neither too tight nor too loose.

If any marks are found within the telescopics or main frame where the rollers have been running, they should be removed with a sanding disk with an 80 grit paper. Do not attempt to remove all marks, only the ridges.

A properly adjusted mast should show no more than a 0.5 inch (12 mm) mark where the roller touches the respective telescopic or main frame. The assembly should be shimmed to the tightest spot on the assembly (as the rollers run up and down the rail). Small areas that are slightly higher than the rest of the web can be buffed to avoid shimming the major portion of the rail too loose.

Bearings, Reach Half Shaft

Removal

1. Place 4 x 4 in. blocks where the tips and base of the forks will touch the floor when lowered.
2. Fully extend the reach mechanism and lower the forks onto the blocks.
3. Turn the key switch OFF and disconnect the battery connector.

▲ CAUTION

You must support the forks with blocks when performing this procedure. Otherwise you may bend or damage the half shaft bolts.

4. Remove the cap screw.
5. Wedge the half shafts apart.
6. Pry the damaged half shaft from the assembly.

Installation

1. Install the inner half (threaded) into the bearing and start it into the carriage frame weld.
2. Install the outer half (countersunk) into the bearing and start it into the carriage frame weld.

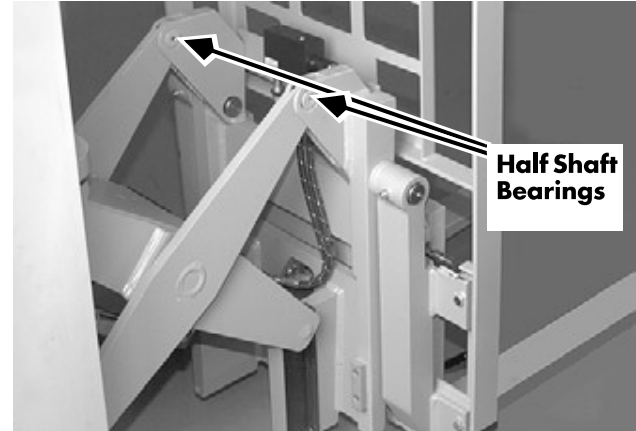

Figure 7-255: Half Shaft Location

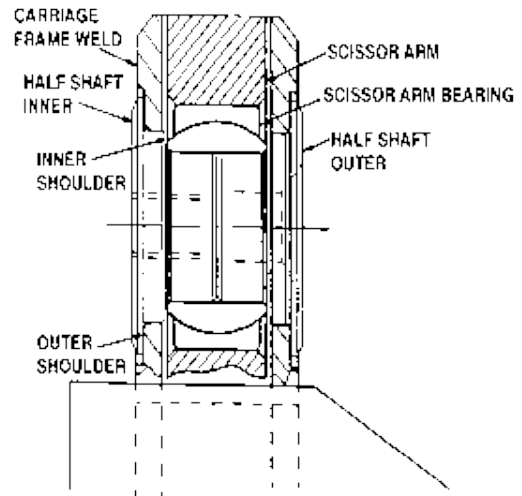

Figure 7-256: Half Shaft Assembly

Mast, Chain, Hose and Cable

Removal (with Tilt and no Sideshift)

3. Carefully lower the bend in the fork toward the cutout until the fork is in position at the lower cross member.
4. Slide the fork to the desired location on the carriage.
5. Push the fork latch down to lock it. The latch will engage if the fork is over one of the slots on the upper carriage cross member.
6. Try to slide the fork back and forth to be sure it is locked into position.
7. Replace the safety bolt.
8. Reconnect the battery connector.

Removal (with Tilt and no Sideshift)

1. Turn the key switch OFF and disconnect the battery connector.
2. Remove the carriage load backrest. See [Figure 7-269](#).
3. Release the fork locking mechanism by lifting up the latch on top of the fork.
4. Slide the fork off the end of the carriage.

Installation (with Tilt and no Sideshift)

1. Place the fork on the end of the carriage and slide it into position.
2. Push the fork latch down to lock it. The latch will engage if the fork is over one of the slots on the upper carriage cross member.
3. Try to slide the fork back and forth to be sure it is locked into position.
4. Re-install the carriage load backrest. See [Figure 7-269 on page 7-299](#).



Figure 7-269: Fork Removal (with Tilt and no Sideshift)

Equalization Chains

Adjustment

The equalization chains on the three-stage masts must be adjusted properly to prevent the possibility of stretched hoses and electrical cables.

The equalization chains are located between the outer telescopic and the main frame.

▲ CAUTION

With both equalization chains slack, note the relationship between the top of the mast main frame and the telescopic frame section. UNDER NO CIRCUMSTANCES should the equalization chains be adjusted so that the inner telescopic is raised above the position noted before starting the adjustment procedure.

1. The equalization chains are properly adjusted if the inner telescopic contacts the mechanical stops on the outer telescopic just before the outer telescopic contacts the mechanical stops on the main frame.
2. The adjusters are located near the top of the main mast, between the mast main frame and the outer telescopic. See [Figure 7-272](#). To adjust the equalization chains, turn the chain anchor locknut until the outer telescopic starts to move, then loosen the nut one-half turn. Repeat this step for the other side.
3. Check the adjustment by elevating the carriage (if required) so that 4 to 5 feet (1.2 to 1.5 m) of the equalization chains are visible.
4. Turn the key switch OFF and disconnect the battery connector.

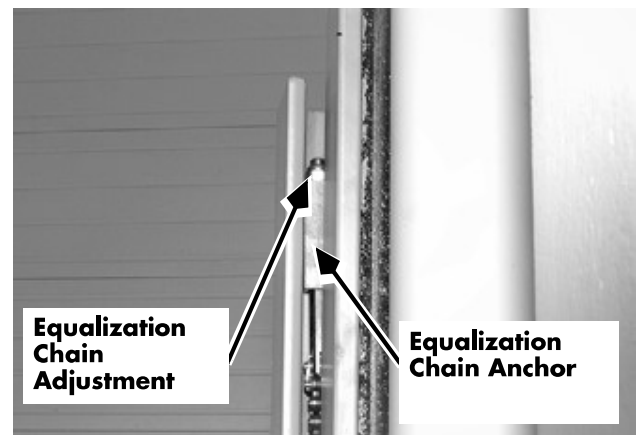

Figure 7-272: Equalization Chain Adjustment



Mast, Chain, Hose and Cable

Disassembly

4. Remove the bolt which secures the wheel positioner cylinder to the caster. Swing the cylinder aside, retaining the washers.
5. Remove the outboard caster switch bracket screw and loosen the inboard screw. Move the switch bracket back and tighten down the inboard screw. This step helps protect the caster switches from damage during this repair.
6. Using a punch and hammer, drive out the axle retaining pin (dowel pin) on the inboard side of the caster. An offset punch may facilitate removal.
7. Using a hammer and bar stock, drive the axle out. If reinstalling the same wheels, be careful to retain the four (4) sets of shims (inboard and outboard side of each wheel) in their proper order; remove the wheels and keep in their original position. (Mark with an indelible marker.)
8. Rotate the caster housing counter-clockwise to its stop. Loosen the thrust bearing nut. Only about 1/4 turn of rotation is possible at a time. Rotate the caster housing counter-clockwise after each 1/4 turn.
9. Shim under the caster housing with 2x4-inch lumber to minimize the drop when the thrust bearing nut is removed. Remove the locking thrust bearing nut, washer, and tapered swivel bearing.
10. If replacing wheels, it is suggested that the wheel bearings also be replaced.
11. To remove the wheel bearings when the wheels are to be reused, gently tap each bearing out, using a hammer and punch or bar stock. Clean and repack the bearings with wheel bearing grease.



HTI Codes and Troubleshooting

NOTE: The following HTI fault codes appear on the HTI display, not the main Operator Display.

Code E1

Code Title	Code E1 - Encoder Channel Failed
Reason	An expected signal from height encoder channel A or B was not received.
System Response	
HTI Display	E1
Performance Limits	
Travel System	Operational
Lift/Lower System	Operational
How to Clear	
Possible Causes	Malfunctioning encoder Bad cable harness or connector

NOTE: For information on how to use HTI Active Maintenance Mode, see [“HTI Active Maintenance Mode”](#) on page 7-331.

Options

HTI Display Card

7. **Slowly** elevate the fork carriage and verify that the encoder bracket assembly clears all mast crossties and the captive plate overing hoses and cables. Verify that the cable is tracking properly. Lower the fork carriage all the way.
8. Turn the key switch OFF and disconnect the battery connector.
9. Check to be sure the cable is tracking parallel in the fore-aft dimension as it passes around the encoder pulley. If the cable path is not parallel, adjust the encoder bracket in its elongated holes until the cable path is parallel.

HTI Display Card

Removal

1. Turn the key switch OFF and disconnect the battery connector.
2. Remove the display housing from the mast.
3. Remove four (4) screws securing the back of the housing.
4. Disconnect the cable harness at the HTI display card.
5. Remove four (4) screws securing the HTI display card to the housing.

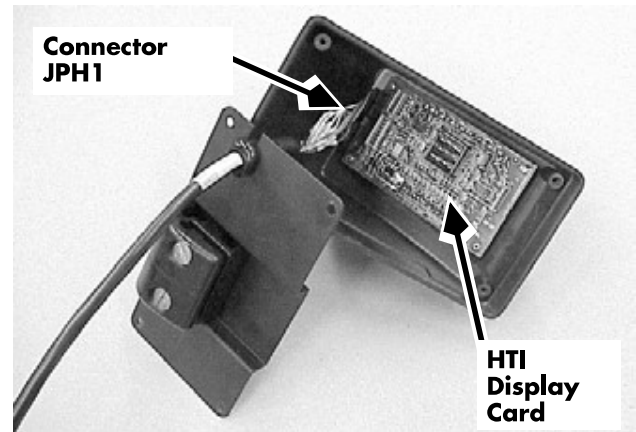

Figure 7-297: HTI Display Card



Operation of the Travel System

Connecting Battery, Three-Motor Configuration

NOTE: Refer to [Figure 8-2 on page 8-4](#) and [Figure 8-3 on page 8-5](#).

All measurements are with respect to TP4 (B-).

When a properly charged battery is connected to the lift truck and all fuses are good, battery positive is present at the following:

1. B+ side (PC-1) of the open PC contactor tip.
2. JPS14-12 and JPS14-13 (B+) on the System Card.
3. FU4 on the System Card.
4. JPS7-13 on the System Card to S1-2.

Operation of the Travel System

Turning Key Switch (S1) ON, Four-Motor

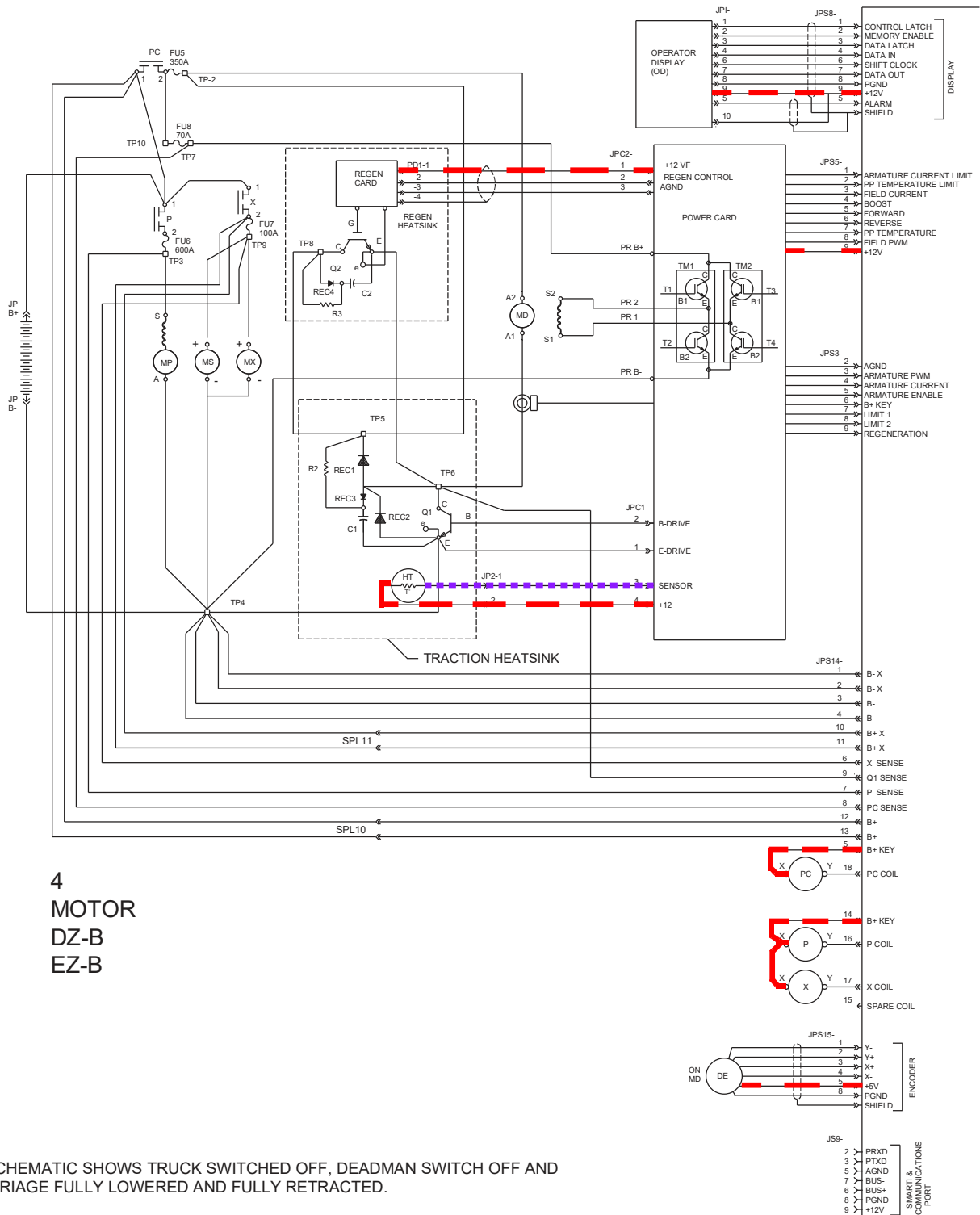



Contactor Coils

The coil drivers allow the use of 24 volt contactor coils even on a 36 volt lift truck. This is accomplished by the System Card determining the voltage of the battery and pulsing the appropriate contactor coil to a level that does not exceed 24 volts.

For a 24 volt lift truck, the contactor coils would not need to be pulsed, therefore the coil (when energized) will be on all the time. However, on a 36 volt lift truck, the coil (when energized) is pulsed at a rate of 66% ON and 34% OFF, (36 volts X 0.66 = 24 volts).

In **Figure 8-15**, three separate test points are shown, with the resulting readings, that would be found in both energized and de-energized states.

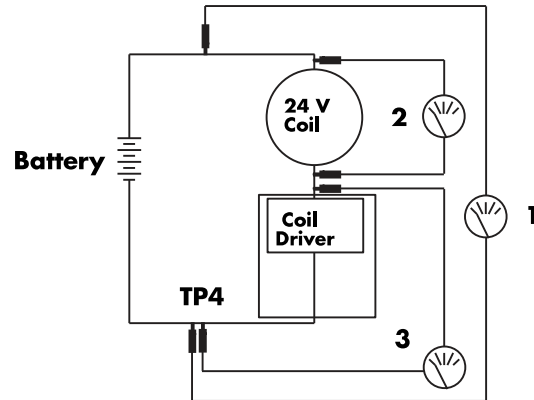

Figure 8-15: 24 Volt Contactor Coil Voltage Readings

	Contactor State			
	Not Energized		Energized	
	Battery Voltage		Battery Voltage	
Test Case	24V	36V	24V	36V
1	24	36	24	36
2	0	0	24	approx. 24
3	24	36	< 1.0	approx. 12

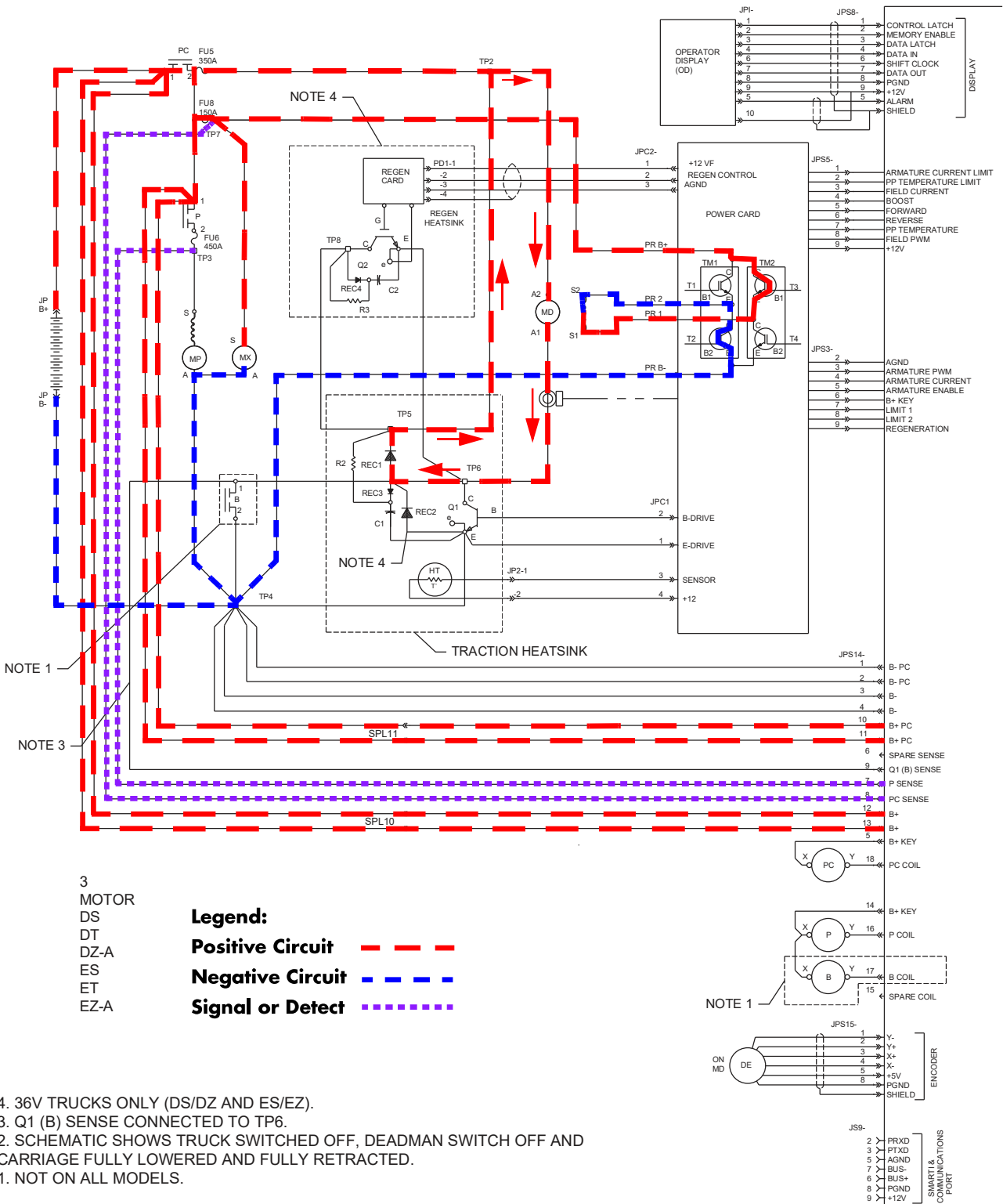
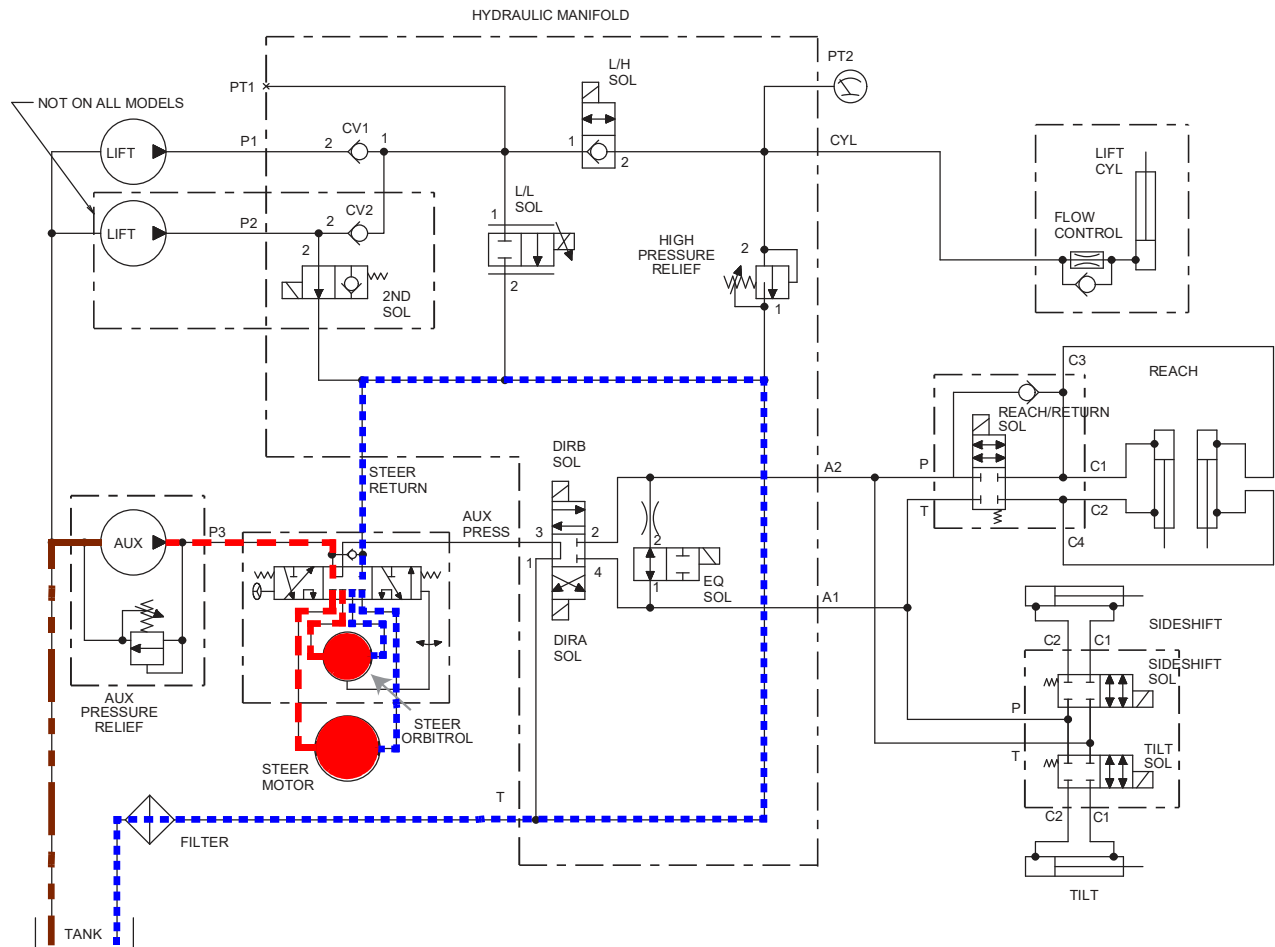
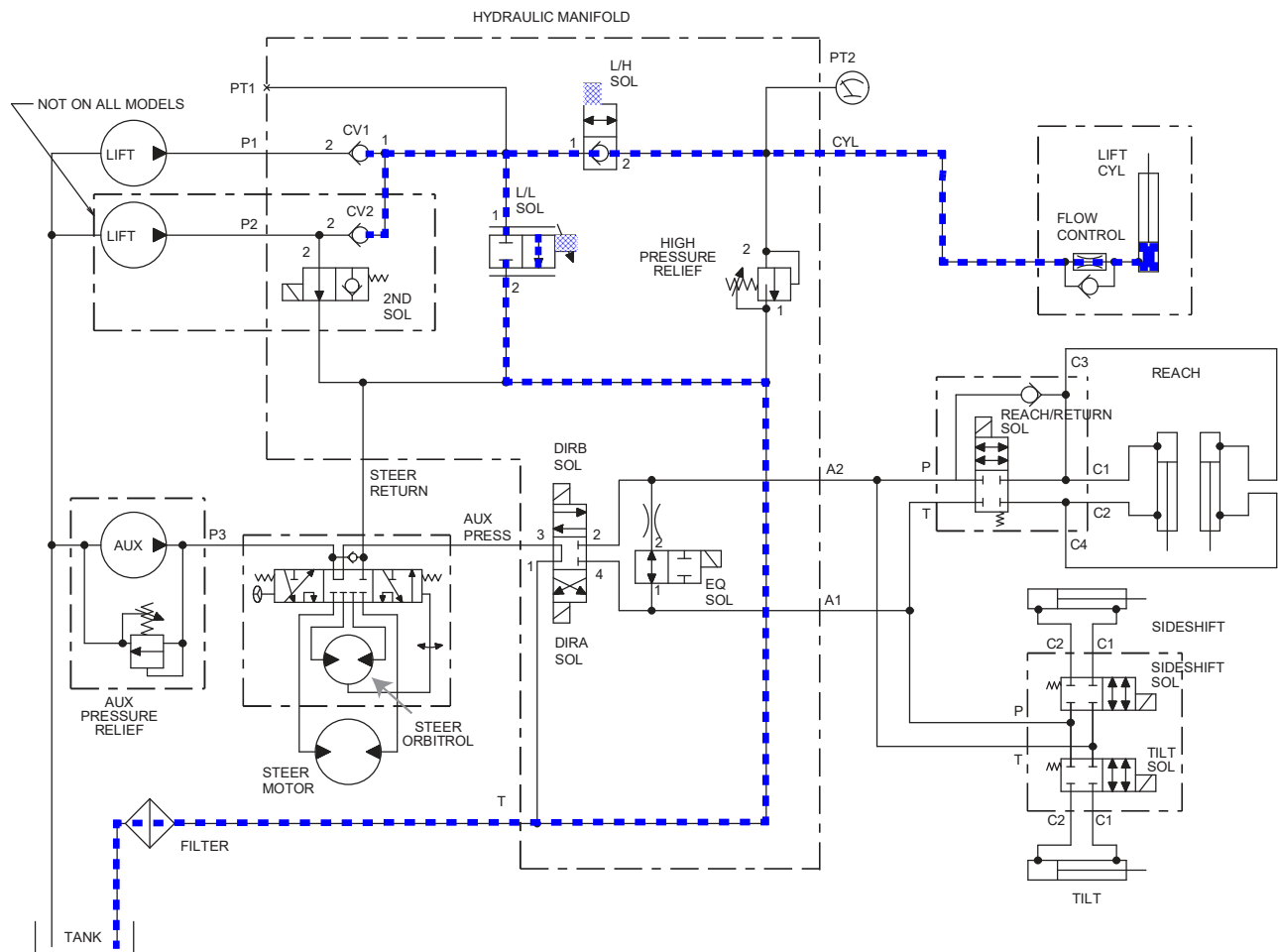

Figure 8-21: Recirculation and Proportional Plugging



- Legend:**
- Pressure Line - - - - -
 - Return Line
 - Suction Line - - - - -
 - Electrical Control Signal

Figure 8-25: Hydraulic Schematic - Steering Theory, 3-motor



Legend:

- Pressure Line** - - - - -
- Return Line** - - - - -
- Suction Line** - - - - -
- Electrical Control Signal** [Blue hatched box]

Figure 8-33: Variable Lower - Hydraulic

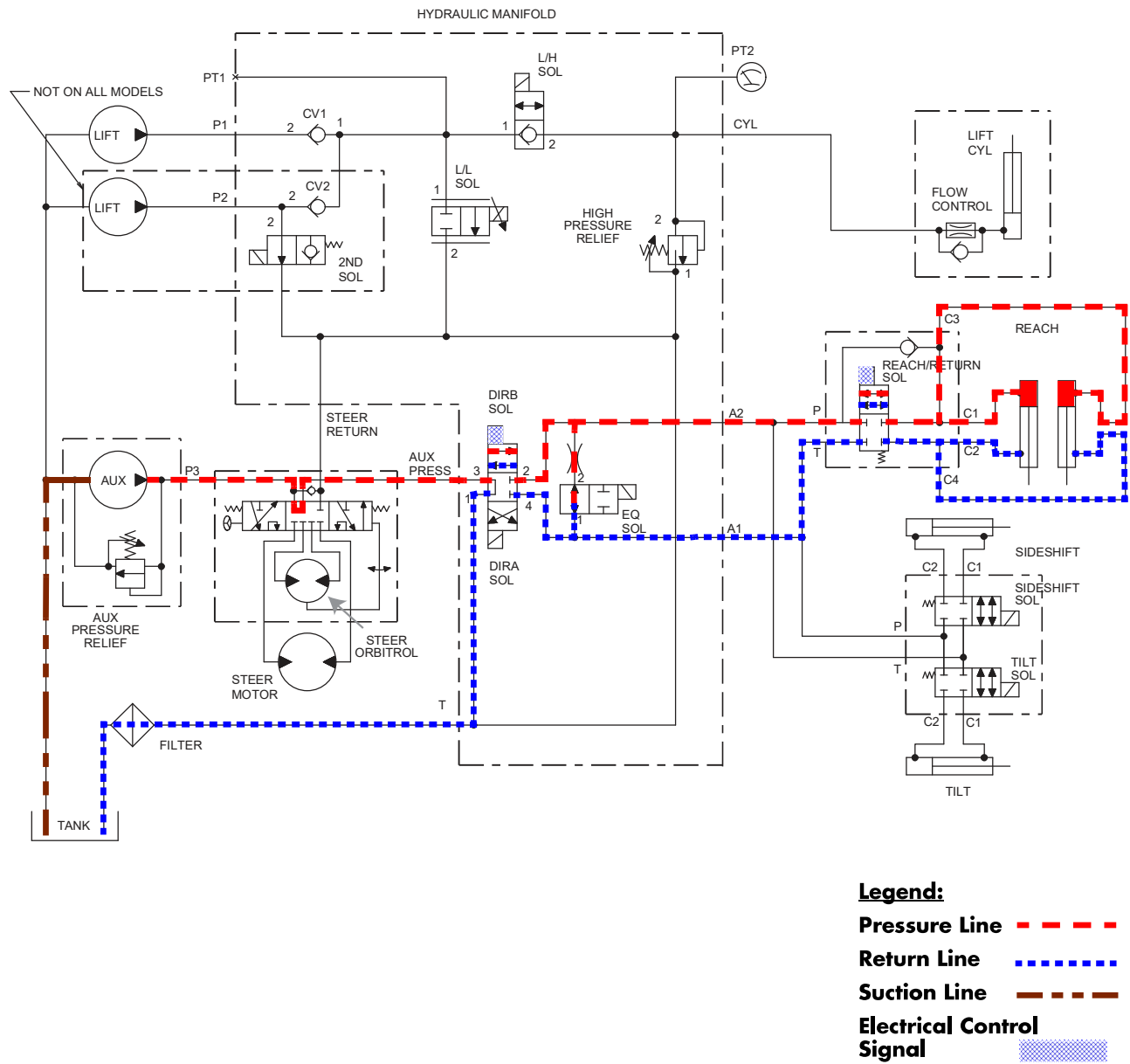
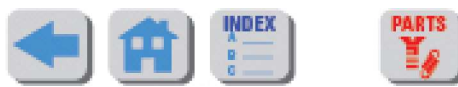

Figure 8-40: Hydraulic Schematic - Reach, Three-Motor, slow speed



4-D® Control

Software Control

Four-direction operation of the EASi™ Reach lift truck is accomplished with software.

Four-direction operation is monitored by the decal membrane circuit of the 4-D control panel mounted on the mast guard. The 4-D control panel consists of a drive wheel LED display, a 4-D caster wheel LED display, and a ROTATE button, which toggles a membrane switch (S60).

4-D Caster Wheel Position

The circular lighted pad in the upper right of the 4-D control panel symbolizes the direction of the 4-D caster wheel. Cross hair LEDs indicate the caster direction. When the ROTATE button is pressed, both cross hairs illuminate until the caster rotation is completed. Caster wheel rotation normally takes approximately 2.5 seconds to complete. When caster wheel rotation completes normally, the cross hair LEDs then indicate the direction of the caster, either fore-aft (front) or crab (sideways).

If the caster wheel input sensors (switches S61 and S62) do not sense the proper position within 4 seconds, the 4-D caster wheel is rotated to the opposite position. If the caster wheel input sensors do not sense the proper position within 4 seconds, a Fault Code GB will occur. Turn the key switch OFF to reset. A reset is required to protect an operator from moving the lift truck, not realizing the caster wheel may be in the opposite position expected.

Drive Wheel Position

The “C” shaped lighted pad in the lower left of the 4-D control panel indicates the rotation direction of the drive wheel. As you rotate the steering wheel, the drive unit proximity sensor (S63) monitors the drive motor and wheel rotation. LED indicators illuminate around the “C” shaped symbol to indicate the direction of the drive wheel. These LEDs are under software control, based on the drive wheel position. Two arrows, one at the 12 o'clock position, the other

at the 9 o'clock position, indicate optimum position of drive wheel for forward and side travel, respectively.

Caster Wheel Position at Vehicle Power-Up

At vehicle power-up, software checks the vehicle model number to determine if the lift truck is a 4-D lift truck. If so, it activates a 4-D monitor task to oversee conditions unique to 4-D operation. During vehicle power-up, all the LEDs of the drive wheel indicator pad of the 4-D control panel illuminate momentarily. (The 4-D caster wheel indicator pad will show the current caster wheel orientation.)

The 4-D caster wheel position is checked. If neither the fore-aft nor sideways travel position can be verified, the software automatically attempts to position the 4-D caster wheel in a fore-aft position. This eliminates the need for a special operator prompt to move the caster wheel to a known position.

Fore-Aft Travel

If the 4-D caster wheel is not already in fore-aft orientation, press the ROTATE button to position the 4-D caster wheel. Rotate the steering wheel to activate the green LED below the forward (12 o'clock) arrow. The lift truck is now positioned for forward travel.

As you rotate the steering wheel clockwise, the drive wheel rotates counter-clockwise. As you rotate the steering wheel clockwise from straight ahead, the LED at the 11 o'clock position illuminates. As the drive wheel approaches the 9 o'clock position, the green LED by the side arrow begins flashing, the lift truck beeps once, and a message appears on the Operator Display Interface: “Approaching Restricted Area.”

As you rotate the steering wheel to its clockwise limit, the red LED illuminates at the 7 o'clock position. At this point the drive wheel, relative to the 4-D® caster wheel, is in a position which



Thread Adhesives, Sealants, and Lubricants

Application	Raymond P/N	Loctite* Number/Color
Thread-locking 1/4" and below	990-403	222/Purple
Thread-locking 1/4" to 3/4"	990-536	242/Blue
Thread-locking 1/4" to 3/4" contamination tolerant	990-462	243/Blue
Thread-locking 1" and under	990-544	271/Red
Thread-locking 1" and under, contamination tolerant	990-463	603/Green
Thread-locking 1" and over	990-571	277/Red
Thread-locking Cleaner	990-538	707
Thread-locking Primer	990-533	T747
Hydraulic Sealant	990-552	569
Molybdenum Anti-Seize Compound (Molykote)	990-638	/Silver
Gasket Cement	990-556	596/Red
Corrosion Inhibitor Coating	990-456/001	
Silicone Sealant (cold storage)	990-564	

Figure A-2: Thread Adhesives, Sealants, Lubricants

NOTE: * Loctite is a registered trademark of the Loctite Corporation. Brand endorsement is not implied here, but listed only as a commonly identified product.



Electrical Schematics



A

|

B

|

C

2

AUX POWER (BATTERY)

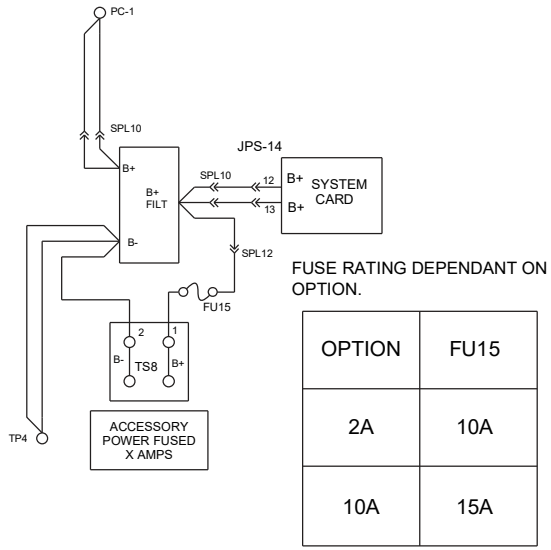

3

4

5

AUX POWER (KEY)

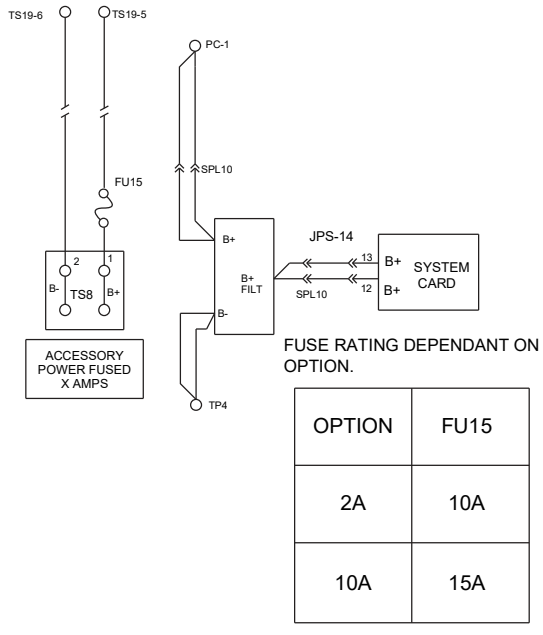

6

7

Figure A-18: Options (Elec. Schematic, Sheet 5, Part 1 of 3)



IDENTIFIER	SHEET	COORDINATES	DESCRIPTION
TP2	1-3	C2	TIE POINT ON FU5 (B+PCF)
TP3	1-3	B3	TIE POINT ON FU6
TP4	1-3	B5	TIE POINT FOR B-
TP5	1-3	B4	TIE POINT ON STANDOFF MOUNTED ON HEATSINK (B RECT.)
TP6	1-3	C4	TIE POINT ON HEATSINK (BEHIND RECTIFIERS)
TP7	1-3	B2	TIE POINT ON FU8
TP8	1-3	B3	TIE POINT ON Q2 BUSS BAR (REC4 STUD)
TP9	1-3	C2	TIE POINT ON FU7
TP10	1-3	C2	TIE POINT ON FU8
VR1	1-3	F2	THROTTLE POTENTIOMETER
VR2	1-3	F2	LIFT/LOWER POTENTIOMETER
WL	5	E2	WARNING LIGHT
2ND	1-3	F4	SOLENOID 2ND STAGE LIFT

Figure A-28: Legend (Elec. Schematic, Sheet 5, Part 3 of 3)



Pressure Adjustment
 Auxiliary System 7-204
 Lift 7-200
 Steering (EZ-B/DZ-B) 7-208
 Pressure Switch, HTI 7-343
 Adjustment 7-344
 Pressure Transducer 7-225
 Program Mode 3-8, 6-5, 6-7
 PROM Replacement 7-116
 Proportional Valve, Adjustment 7-223
 Proximity Sensor 6-119, 7-191
 4-D 7-188
 Proximity Sensor Sensing Ring, 4-D .. 7-191
 Pump
 Auxiliary 7-202
 Lift 7-198
 Steering 7-206

Q

Q1 Power Transistor 7-163
 Q2 Transistor 7-166

R

Reach Carriage Bearings 7-288
 Reach Cylinder 7-253
 Reach Functions, Troubleshooting ... 5-20
 Reach Half Shaft Bearings 7-289
 Reach Manifold 7-218
 Reach/Retract
 Switch 7-55, 7-67
 REC1 7-168
 REC2 7-168
 REC3 7-168
 Rectifiers 7-168
 Regen Assembly 7-166
 Relay
 Horn 7-157
 Relay, Key Switch 7-32, 7-137
 Resistor 7-171
 Retract Functions, Troubleshooting ... 5-21
 Rollers, Battery 7-112
 Run Mode 3-8, 6-5
 Tones 6-6

S

Scheduled Maintenance 4-2 to 4-10
 180 Day 4-9, 4-10
 30 Day 4-5
 360 Day 4-10
 Guidelines 4-2
 Photos 4-11
 Schematic, Electrical
 EF A-16 to A-17, A-30
 ES/ET/EZ-A/DS/DT/DZ-A A-14 to A-15
 EZ-B/DZ-B (4-motor) A-18 to A-19
 Fork Height/Tilt Indicator 7-346
 Legend A-31 to A-33
 Options A-20 to A-30
 Schematic, Hydraulic
 EF (4-D) A-38
 ES/ET/EZ-A/DS/DT/DZ-A (3-motor) A-36
 EZ-B/DZ-B (4-motor) A-37
 Seal
 Front & Back Lift Cylinder Repacking 7-247
 Side Lift Cylinder Repacking 7-244
 Sealing, Cold Storage 7-326
 Sensor
 Drive Motor Temperature 7-151
 Lift Motor Temperature 7-151
 Power Panel Temperature 7-151
 Sheave, Equalization Chain 7-313
 Shimming
 Fork Carriage 7-342
 Inner Tele to Carriage 7-285
 Main Frame to Outer Tele 7-281
 Mast Bearing 7-277 to 7-287
 Outer Tele to Inner Tele 7-283
 Short Circuited Armature or Field Winding
 7-130
 Shorts to Frame Test 5-6
 Sideshift Cylinder 7-262
 Sideshift Functions, Troubleshooting .. 5-19
 Sideways Travel 8-74
 Sight Glass, Reservoir 7-197
 SMARTi Module 7-184
 Snubber 7-171
 Snubber Resistor 7-171
 Software Replacement 7-116
 Soldering Procedures 7-120
 Solenoid 7-221
 4-D Caster Wheel Positioner 7-223
 General 7-220
 Installation, General 7-220
 Special Tools 7-216, 7-221

**PARTS
AVAILABILITY:**

Now available through the Parts Distribution Center.

**FILING
INSTRUCTIONS:**

File this notice in Maintenance Manuals:

- 1031794B (5400/5500/5600) next to page 7-61
- 1043922A (5200) next to page 7-47
- 1112860B (7500/7520) next to page 7-69
- 1137893B (7700/7720) next to page 7-59
- 1119847A (EZ-C/EZ-D) next to page 7-77
- 1031940A (ET-F) next to page 7-53
- PDMM-0080-01 (EF) next to page 7-109
- 1193671A (4150/4250) next to page 7-49
- 1119828C (4150/4250) next to page 7-51
- 1089040B (9600/9700) next to page 7-39
- 1089026A (9300/9400) next to page 7-41
- PDMM-0092 (TRT) next to page 7-148

RAYMOND SERVICE INFORMATION

The Raymond Corporation
Corporate Headquarters
P O Box 130
Greene, New York 13778-0130



RSI GEN-12-002
April 24, 2012

Model
General

SUBJECT: Static Strap Resistance

GENERAL INFORMATION: A black standoff (P/N 1077426) with an internal resistor is now provided with static strap assemblies on new trucks and is available as a field replacement for the original red standoff (P/N 170-000-703).

SERVICE INFORMATION: When inspecting static strap assemblies that use the black standoff, the resistance between the drag cable and the truck frame must be between 200K and 250K. If it is found to be outside these values, replace the standoff and/or drag cable as necessary.

PARTS AVAILABILITY: Now available through the Parts Distribution Center.

FILING INSTRUCTIONS: File this notice in all Maintenance Manuals that are equipped with static strap assemblies.

RAYMOND SERVICE BULLETIN

The Raymond Corporation
Corporate Headquarters
PO Box 130
Greene, New York 13778-0130



RSB RCH-03-003
July 14, 2003

Models
Reach Trucks EZ, DZ, EF, ET, ES, DT, DS

SUBJECT: Half Shaft Roll Pins

DESCRIPTION: The cap screw securing the half shafts may have a tendency to come loose on Reach trucks built after the serial numbers listed below:

EZ-A-01-21662	ET-C-01-11065
EZ-B-01-21677	ET-D-01-11053
EF-A-01-21710	ES-D-01-11055
DZ-A-01-21667	DT-D-01-11050
DZ-B-01-21887	DS-D-01-11052

REMEDY: Future production trucks will contain additional slots and roll pins.

Procedures to alter carriage frames requiring additional roll pins begin on page two of this bulletin.

- Slide the lift/lower potentiometer bracket into the slot in the right control handle shell. Push the bracket down with your thumb so the retaining foot rests on the flat of the tilt/sideshift card. See Figure 7. Note the routing of the lift/lower potentiometer wires. Make sure the potentiometer shaft turns freely. If not, check for wires pulled too tight.

Cable Routing

- Make sure all wires and cables are routed correctly. Insert the cable stud and washer.

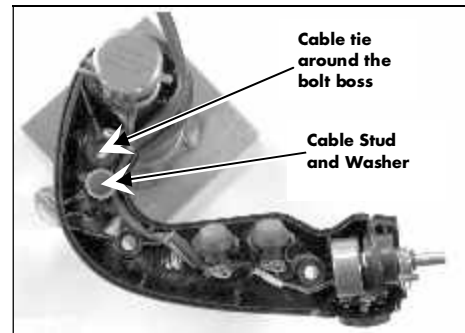

Figure 11: Control Handle cable routing

- Install a cable tie to hold the travel potentiometer wires away from the button head screw on the travel potentiometer positioner. Place the cable tie around the potentiometer wires and the bolt boss (See Figure 11). This will eventually be held in place by the top half of the handle.
- Make sure the locating tab on the travel potentiometer (VR1) is 180° from the dowel pin on the potentiometer positioner. See Figure 12.

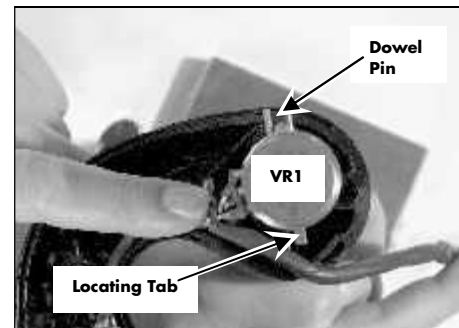

Figure 12: Travel Potentiometer orientation

Tilt/Sideshift Button Installation

- Rotate the entire handle and fixture so that the tilt/sideshift actuator is flat.
- Install the tilt/sideshift actuator, spring, and button. Move the button toward the lift/lower potentiometer until the button drops into the locating ridge. The button notch should engage in the key. Make sure the spring is fully engaged at both ends. See Figure 13.

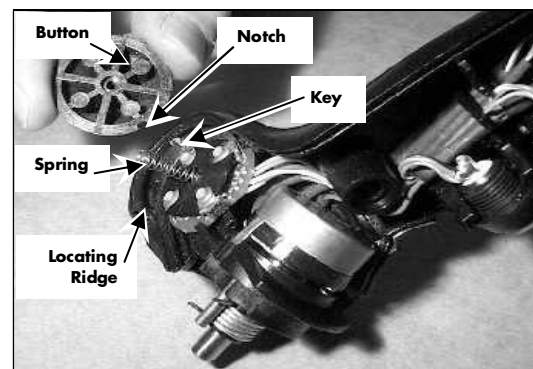

Figure 13: Tilt/Sideshift Button Installation

RAYMOND PRODUCT IMPROVEMENT NOTICE

The Raymond Corporation
Corporate Headquarters
PO Box 130
Greene, New York 13778-0130



RPIN RCH-02-R002A
June 28, 2002

Reach Truck Models
EZ-A, EZ-B, DZ-A, DZ-B, EF-A

NOTE: This notice supersedes RPIN No. RCH-02-R002, dated May 14, 2002. Changes made to this document are marked with a change bar to left of the text.

SUBJECT:

1. Loss of full travel speed and possible sluggish acceleration.
2. Occurrence of code 26 when exiting Configure Mode.

DESCRIPTION:

1. When an operator is driving away from a pick face, accelerating and simultaneously lowering the forks, the system has difficulty determining the actual load weight. This can happen when the truck is unloaded or lightly loaded. As a result, it must assume a load weight greater than 1500 lb., thereby reducing acceleration and limiting top travel speed to 7.0 MPH.
2. When SMARTⁱ is connected, a code 26 may occur when exiting configure mode after a change has been made while in configure.

REMEDY:

1. Trucks with less than a 21" battery compartment and a top speed of 7.5 MPH, can now have a new option enabled that will prevent limited travel speed regardless of the weight on the forks.

DTIC version 5.6 is required to view the new option. Older versions of DTIC (before version 5.6) will read this new option as "Future Option Bit S". An S-207 must be submitted to request enabling it.

With the installation of the new firmware and DTIC, reduced acceleration has been removed for all EASi Reach-Fork[®] lift truck models and loads.

2. This firmware contains changes which will reduce the occurrence of a code 26 when exiting Configure Mode.

CLICK HERE TO **DOWNLOAD** THE COMPLETE MANUAL

- Thank you very much for reading the preview of the manual.
- You can download the complete manual from: www.heydownloads.com by clicking the link below



- Please note: If there is no response to CLICKING the link, please download this PDF first and then click on it.

CLICK HERE TO **DOWNLOAD** THE COMPLETE MANUAL