

QXR MAINTENANCE MANUAL

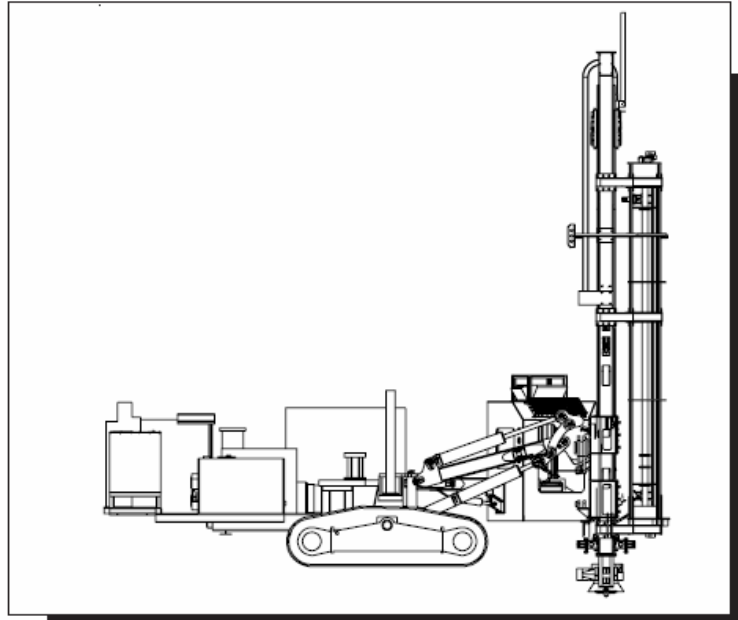

QXR 920 SURFACE DRILL . . .



CANADIAN DRILLING TECHNOLOGY

CLICK HERE TO **DOWNLOAD** THE COMPLETE MANUAL

- Thank you very much for reading the preview of the manual.
- You can download the complete manual from: www.heydownloads.com by clicking the link below



- Please note: If there is no response to CLICKING the link, please download this PDF first and then click on it.

CLICK HERE TO **DOWNLOAD** THE COMPLETE MANUAL



Drill Operation and Maintenance Safety

Read all safety instructions provided here and those provided in the Operator's Manual before operating and servicing the drill. General safety and accident prevention regulations laid down by local authorities must also be followed.



General Safety Instructions

1. Observe all safety procedures when operating and servicing the equipment.
2. Be completely familiar with operating and maintenance procedures before inspecting, operating, or servicing the drill or booster. You must read and understand all procedures described in each manual.
3. Do not inspect or repair any components without properly shutting down drill, water pump, and air supply.
4. Keep all non-essential personnel away from operator's controls and maintenance area while service work is in progress.
5. Any modifications to controls or operating procedures must be noted clearly on equipment and all operators must be advised of changes.
6. Inspect hoses, hose connection safety devices, fittings, and supply lines at frequent intervals for indication of wear or damage. Repair or replace damaged components immediately.
7. Check all bolts, nuts, and adjustments frequently for proper tension. Check all fluids at recommended intervals.
8. Do not stand under mast at any time.
9. Disconnect electrical power supply to drill and booster before washing.
10. Wear protective gear when operating, diagnosing, or servicing the equipment.
11. Do not weld or grind near electrical wiring or supply lines.
12. Keep hands, clothing, rags, and tools away from moving parts.
13. Keep shields and guards in place. Do not operate equipment with electrical panel door open.
14. Keep safety and instruction decals clean. Replace them if they are not clearly legible.

2.0 GENERAL MAINTENANCE (08/03/25)

2.0 GENERAL MAINTENANCE



**READ INSTRUCTIONS BEFORE
SERVICING OR OPERATING!**

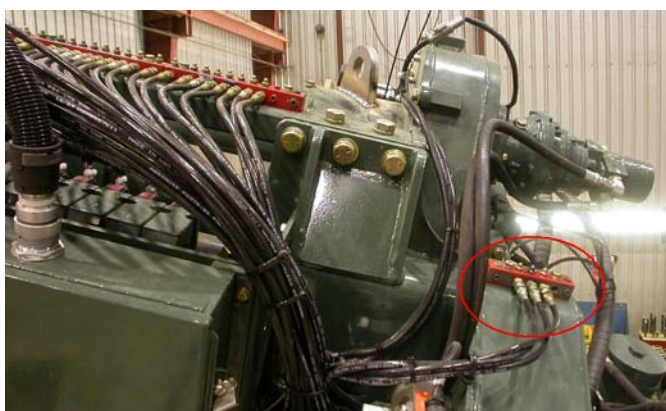

Fig 2.3.6 Grease Blocks on Mast

Greaser Assembly

Greaser with cable reel for greasing pins and bushings on body of QXR. It is mounted on the front of the drill beside the right track.



Fig 2.3.7 Greaser Assembly

6. Check Fuel System (refer to Fig 2.3.19)

- Check the fuel system for damaged fuel lines or leakage.
- Make sure the clamps on the fuel lines are secure.

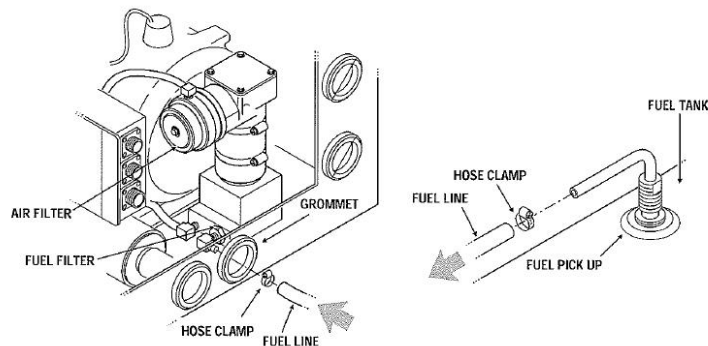

Fig 2.3.19

7. Check Fuel Filter (refer to Fig 2.3.20)

- Remove and inspect filter. Clean or replace as necessary.

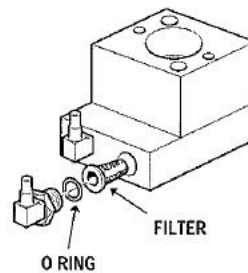

Fig 2.3.20

8. Clean Nozzle (refer to Fig 2.3.21)

- To properly clean the nozzle, use a degreaser/cleaner or carburetor cleaner in a spray can. This will wash any dirt out and leave no residue. When using compressed air, blow into the nozzle orifice from the head end.

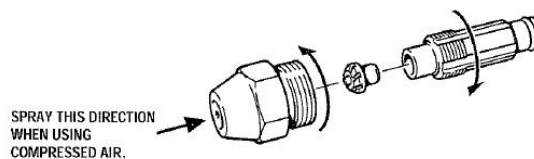

Fig 2.3.21



SEBF8492
May 2002

Caterpillar Industrial Products, Inc. Support Literature



Owner's Manual

CIPI Undercarriage

178-1307	Hewitt	9Q-5044 (C)	9Q-5175	9Q-5464	9Q-5730 (B)
180-4029	Forest	9Q-5065	9Q-5195	9Q-5504	9Q-5731 (B)
191-4041	Machine (A)	9Q-5082	9Q-5198	9Q-5514 (D)	9Q-5741 (D)
192-7634		9Q-5090	9Q-5206	9Q-5617	9Q-5742 (D)
192-9013	3Q-6662	9Q-5093 (D)	9Q-5232	9Q-5618	9Q-5747
199-7942		9Q-5115	9Q-5255	9Q-5643	9Q-5758
204-9207	6Z-7861	9Q-5118	9Q-5259	9Q-5651	9Q-5826 (C)
208-5845	6Z-7885	9Q-5126	9Q-5262	9Q-5716	9Q-5831
213-3892	6Z-7947	9Q-5135	9Q-5268	9Q-5727 (B)	9Q-5846
	6Z-7957	9Q-5141	9Q-5412	9Q-5728 (B)	9Q-5847
	6Z-7999	9Q-5168	9Q-5436	9Q-5729 (B)	9Q-5876
					9Q-5912

(A) For Hewitt Forest Machine, refer to SEBF3700 for 173-4600 Final Drive service information.

(B) For 9Q5727, 9Q5728, 9Q5729, 9Q5730, and 9Q5731 arrangements, refer to SEBF3701 for 185-1894 Final Drive service information.

(C) For 9Q5044 and 9Q5826 arrangements, refer to SEBF3702 for 149-3535 Final Drive service information.

(D) For 9Q5093, 9Q5514, 9Q5741, and 9Q5742 arrangements, refer to SEBF3703 for 1C-7183 Final Drive service information.

CIPI Undercarriage



Operation and Maintenance Manual

**CIPI UNDERCARRIAGE Arrangements:
3Q-6662; 6Z-7861, 7885, 7947, 7957,
7999; 9Q-5044, 5065, 5082, 5090,
5093, 5115, 5118, 5126, 5135, 5141,
5168, 5175, 5206, 5255, 5259, 5268,
5412, 5436, 5464, 5514, 5617, 5618,
5716, 5741, 5742, 5758, 5826, 5831,
5846, 5847, 5912; 178-1307, 192-7634,
192-9013, 199-7942, and 208-5845**

L5E1-Up (Machine)
L5J1-Up (Machine)
L5N1-Up (Machine)



Locations of the Identification Plates on the Undercarriage

Type 1

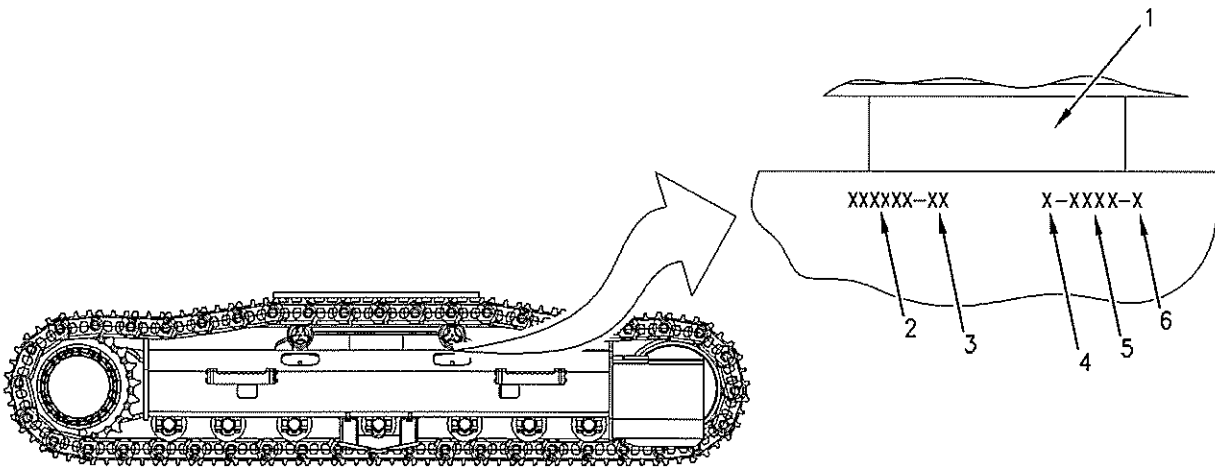

Illustration 7

g00846654

Typical right side view of the undercarriage arrangement

- (1) Carrier roller mounting bracket
- (2) Part number
- (3) Change level
- (4) Facility identification
- (5) Sequential number
- (6) Side identification

Type 2

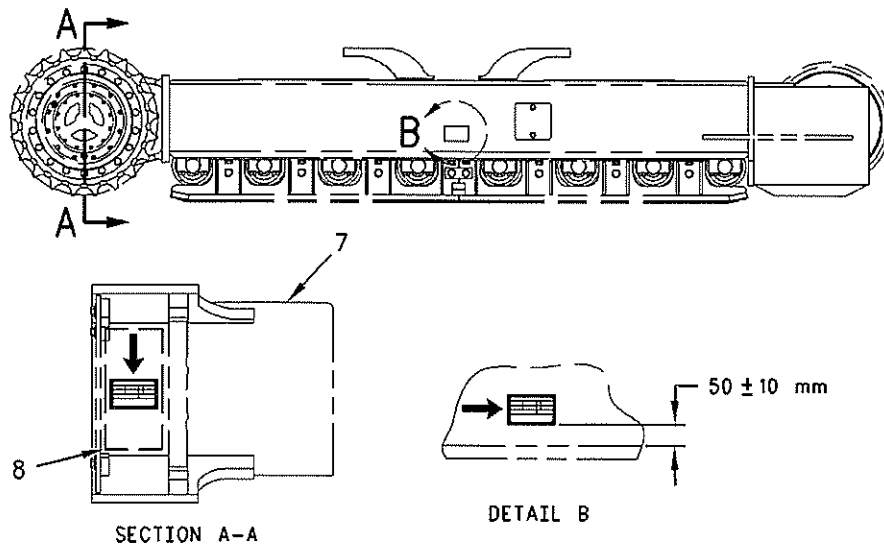

Illustration 8

g00846574

Typical right side view of the undercarriage arrangement

- (7) Bulkhead plate
- (8) Area that is designated for the identification plate

Table 1

COMMERCIAL OILS	
COMPANY	OIL BRAND NAME ⁽¹⁾
Mobil Oil Co., Fairfax, VA	Mobil Trans HD
D-A Lubricant Co., Indianapolis, IN	D-A Torque Fluid 4
Universal Motor Oils Co. Inc., Wichita, KS	Dyna-Plex 21CTO-4 Transmission Oil
Mitsubishi Oil Co., Japan	Mitsubishi TO-4 Oil
Texaco Lubricants Co., Houston, TX	Texaco Transmission Drive Train Oil (SAE 10W and 30 only)
Behnke Lubricants Inc., Milwaukee, WI	Jax Powertran Fluids
Minuteman Lubricants Inc., Cabot, PA	Minuteman TO-4 Special Lubricant
Shell Oil Company, Worldwide	Shell Donax TC Oil
Dryden Oil Company, Baltimore, MD	Dryden Trans C TDTO
Chevron USA, Richmond, CA	Chevron Drive Train Fluid HD (SAE 10W and 30 only)
Black Bear Company, Inc., Long Island, City, NY	Black Bear Transmission Oil TO-4
CITGO Petroleum Corporation, Tulsa, OK	CITGO Transpower Fluid
Pennzoil Products Company, Houston, TX	Pennzoil Power-Tranz TO-4
Valvoline Inc., Lexington, KY	Valvoline DT Transmission Fluid
CONOCO Inc., Houston, TX	Conoco Power Drive 44
Exxon Company, Houston, TX	Exxon Torque Fluid
Amoco Oil Company, Oak Brook, IL	Amoco HD TransOil
GC Quality Lubricants, Inc., Macon, GA	GC Cat Trans30 (SAE 30 only) GC Cat Gear 50 (SAE 50 only)

⁽¹⁾ Unless the oil viscosities are stated otherwise, all of the oils that are listed are SAE 10W, 30 and 50.

The following table contains a list of other oils which can be used.

Table 2

COMMERCIAL OILS	
COMPANY	OIL BRAND NAME
Agip	BLASIA 220
Aral Dego TU 220	Degol BG 220
AVIA	AVILUB RSX 220
Castrol Alpha ZN 220	Alphasyn T 220
DEA	Trion EP 220
ELF ELF EPONA Z 220	REDUCTELF SP 220
FINA	GIRAN L 220
Fuchs	RENEP AWD 220
Klüber	LAMORA 220
Mobil Mobilgear SHC 220	Mobilgear 630
TOTAL	CARTER EP 220
Tribol Tribol 1510/220	Tribol 1100/220

Note: The commercial oils that are listed in Tables 1 and 2 does not constitute an approval by CIPI for usage of these oils. The list is intended to provide you with sources that may meet TO-4 performance levels.

i01660551

S-O-S Oil Analysis

SMCS Code: 7000; 7542

Caterpillar recommends the use of the S-O-S oil analysis program in order to monitor the condition of your equipment. The S-O-S oil analysis program will complement your preventive maintenance program.

The Caterpillar Scheduled Oil Sampling Program was developed in order to help the users of Caterpillar equipment to realize the equipment's full value. The S-O-S program will help the user in minimizing repair costs and maximizing availability. The S-O-S program is a series of diagnostic tests which analyze used lubricating oils from the oil wetted compartments of the equipment. By analyzing the used oils, problems may be identified early before extensive repair cost and downtime are incurred.

Index

B

Burn Prevention.....	8
Oils.....	8

C

Commercial Oils.....	20
Crushing Prevention and Cutting Prevention.....	8

F

Final Drive Oil.....	20
Applications.....	20
Caterpillar Transmission/Drive Train Oil (TDTO).....	20
Final Drive Oil - Change.....	27
Final Drive Oil Level - Check.....	27
Final Drive Ring Gear Removal.....	13
Type "B" Final Drive.....	13
Final Drive Sun Gear Removal.....	14
Type "A" Final Drive.....	14
Type "B" Final Drive.....	14
Fire Prevention and Explosion Prevention.....	8
Fire Extinguisher.....	8
Lines, Tubes and Hoses.....	8
Foreword.....	5
California Proposition 65 Warning.....	4
Caterpillar Product Identification Number.....	5
Certified Engine Maintenance.....	4
Literature Information.....	4
Machine Capacity.....	5
Maintenance.....	4
Operation.....	4
Safety.....	4

G

General Hazard Information.....	6
Asbestos Information.....	7
Containing Fluid Spillage.....	7
Dispose of Waste Properly.....	7
Fluid Penetration.....	6
Pressure Air and Water.....	6
Trapped Pressure.....	6
General Torque Information.....	16

H

Hydraulic Oil.....	19
Applications.....	19
Caterpillar Biodegradable Hydraulic Oil (HEES).....	19
Caterpillar Hydraulic Oil (HYDO).....	19
Commercial Oils.....	19

I

Important Safety Information.....	2
-----------------------------------	---

L

Lubricant Specifications.....	19
Lubricant Viscosities.....	23
Lubricant Viscosities for Ambient Temperatures.....	23
Selecting the Viscosity.....	23
Lubricant Viscosities and Refill Capacities.....	23

M

Maintenance Interval Schedule.....	26
Maintenance Section.....	16

O

Operation Section.....	12
------------------------	----

P

Part Number Location.....	10
Caterpillar Industrial Products, Inc.....	10
Product Identification Information.....	10
Product Information Section.....	10

R

Refill Capacities.....	25
------------------------	----

S

S-O-S Oil Analysis.....	21
Obtaining S-O-S Oil Samples.....	22
S-O-S Interval and Location of Sampling Valve for the Final Drive.....	22
Safety Section.....	6
Standard Torque for Inch Fasteners.....	16
Standard Torque for Metric Fasteners.....	17

i01663260

Track Adjuster

SMCS Code: 4157

Part No.: 102-8109

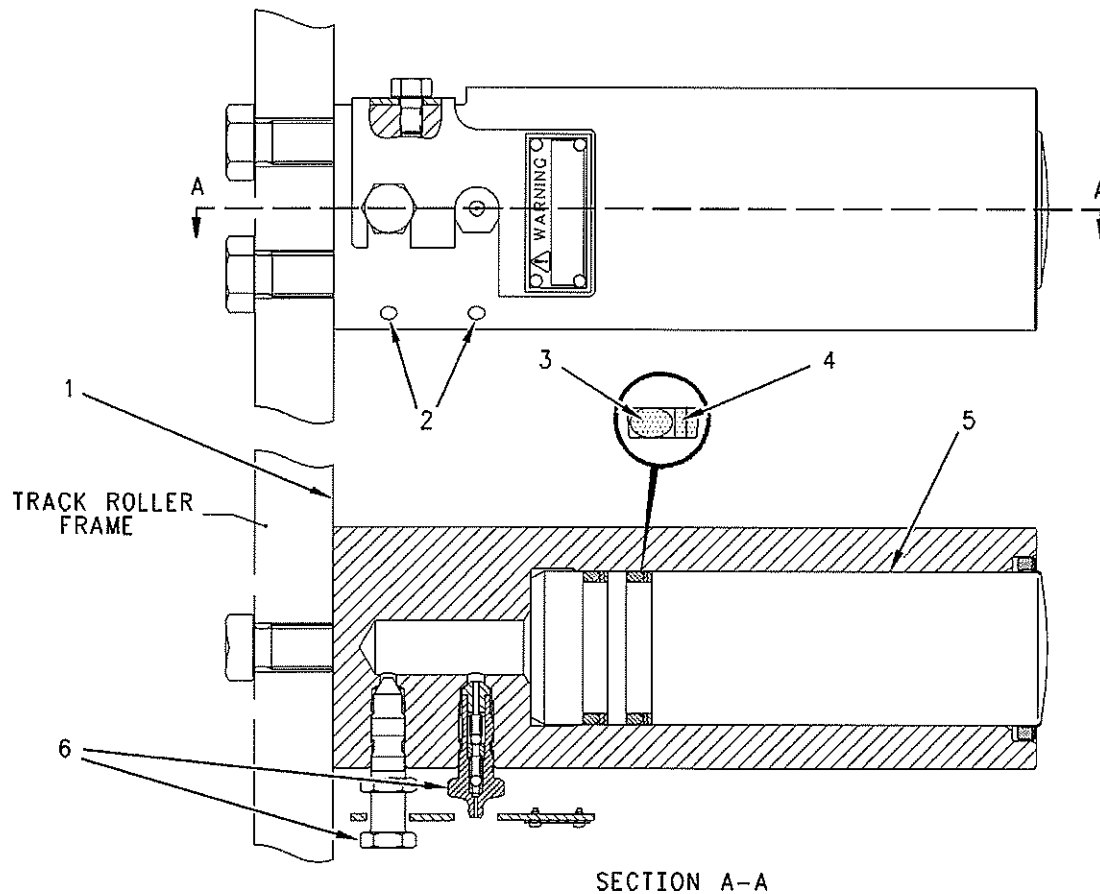

Illustration 13

g00704947

- (1) This surface must be clean and free of protective coating prior to assembly into the track roller frame.
- (2) Fill the relief holes with 2P-9065 Lubricant.
- (4) The brown colored ring should be installed next to seal (3).
- (5) Lubricate the cylinder bore, the piston, and the seal grooves with the lubricant that is being sealed.
- (6) Torque for two valves .. 34 ± 5 N·m (25 ± 4 lb ft)

Table of Contents

Systems Operation Section

Travel System

Motor Control (Travel)	4
Travel Motor	6
Travel Counterbalance Valve	16
Oil Makeup (Travel System)	22
Final Drive	25
Swivel	29

Index Section

Index	31
-------------	----

Parking Brake

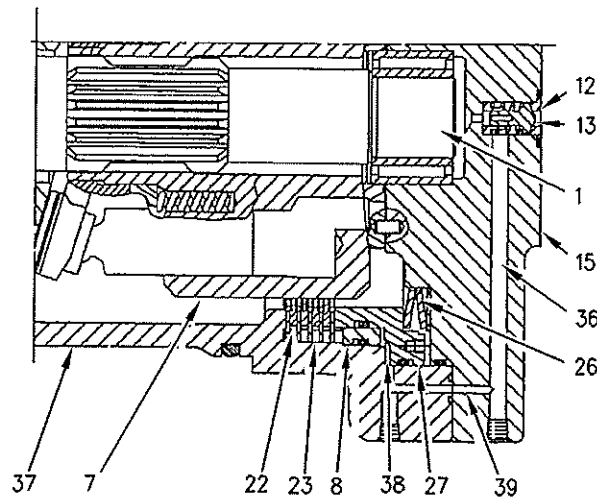

Illustration 14

g00479801

Parking Brake (partial view)

- | | |
|--------------------------|----------------------|
| (1) Drive shaft | (23) Separator plate |
| (7) Barrel | (26) Spring |
| (8) Piston guide | (27) Brake piston |
| (12) Pilot valve (brake) | (36) Passage |
| (13) Port | (37) Housing |
| (15) Head | (38) Piston chamber |
| (22) Friction plate | (39) Passage |

Pump oil is supplied to the travel motor. The parking brake is released and the motor starts rotating. When no pump oil is supplied to the motor, the motor stops and the parking brake engages.

In the parking brake section of the travel motor, separator plate (23) is splined to housing (37). Friction plates (22) are splined to barrel (7).

When no pump oil is supplied to the travel motor, piston (27) is pushed to the left by the force of spring (26). The oil in piston chamber (38) now flows through passage (39) and passage (36). The oil flows through orifice (43) and into the valve of the motor case drain line. Piston (27) moves to the left. Friction plates (22) and separator plates (23) are held together against housing (37). The rotation of the travel motor stops. Drive shaft (1) engages the parking brake.

Orifice (43) restricts return oil flow from piston chamber (38). The restriction of the oil flow delays the application of the parking brake. The parking brake is delayed in order to give the machine time to stop. Earlier wear and/or damage to the machine could result if the machine stayed in motion.

Prior to the operation of the travel motor, oil flows through port (13). The oil pressure opens valve (41). The oil then flows through passages (36) and (39) to piston chamber (38). Brake piston (27) moves to the right against the force of spring (26). The oil that is holding friction plates (22) and separator plates (23) together is released. The release of the oil pressure allows barrel (7) and drive shaft (1) to turn.

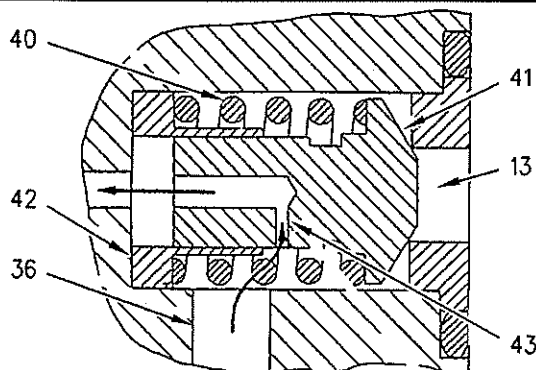

Illustration 15

g00479820

Brake Pilot Valve

- | |
|---------------|
| (13) Port |
| (36) Passage |
| (40) Spring |
| (41) Valve |
| (42) Retainer |
| (43) Orifice |

The oil makeup operation is given with respect to left travel. For right travel, the oil makeup operation is identical.

If the left travel control lever is returned to the NEUTRAL position in order to stop left travel, supply of pump oil to left travel motor (2) is blocked at passage (10). The left travel motor continues to rotate because the machine is still in motion. A negative oil pressure at passage (3) of motor rotary group (1) opens check valve (4).

With left travel control valve (9) in the NEUTRAL position, return oil from passage (11) flows to passage (8). The return oil then goes through line (7), swivel (6), and line (5) into left travel motor (2). The oil passes through opened check valve (4) and passage (3) into motor rotary group (1). This makeup oil eliminates the possibility of cavitation in the travel motor.

Type "B" Oil Makeup Operation

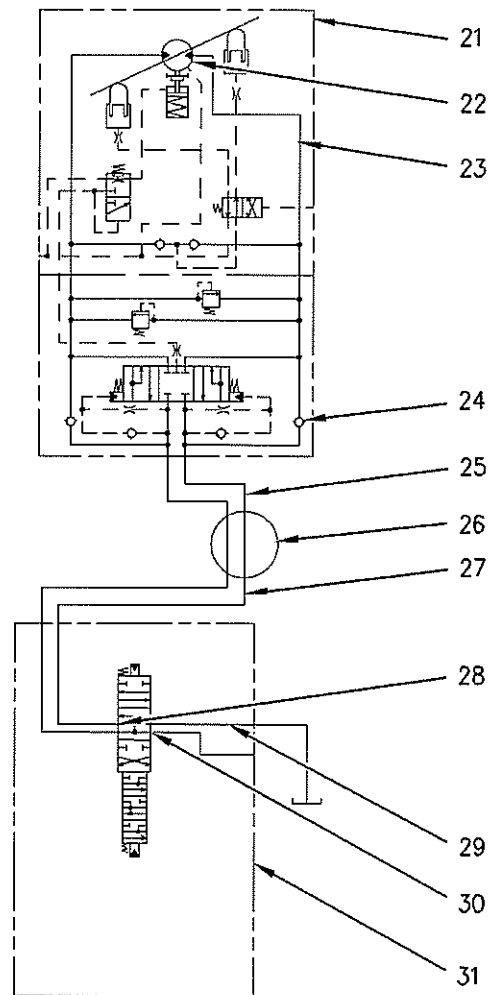

Illustration 26

g00470336

Oil Makeup Circuit

- (21) Left travel motor
- (22) Motor rotary group
- (23) Passage
- (24) Check valve
- (25) Line
- (26) Swivel
- (27) Line
- (28) Passage
- (29) Return passage
- (30) Passage
- (31) Left travel control valve

Return oil from the travel control valve is used as makeup oil to prevent a vacuum condition in the travel motor when operation is stopped.

The oil makeup operation is given with respect to left travel. For right travel, the oil makeup operation is identical.



Testing and Adjusting

CIPI UNDERCARRIAGE Arrangements:
3Q6662, 6Z7861, 6Z7885, 6Z7947,
6Z7957, 6Z7999, 9Q5044, 9Q5065,
9Q5082, 9Q5090, 9Q5093, 9Q5115,
9Q5118, 9Q5126, 9Q5135, 9Q5141,
9Q5168, 9Q5175, 9Q5206, 9Q5255,
9Q5259, 9Q5268, 9Q5412, 9Q5436,
9Q5464, 9Q5514, 9Q5617, 9Q5618,
9Q5716, 9Q5741, 9Q5742, 9Q5758,
9Q5826, 9Q5831, 9Q5846, 9Q5847,
9Q5912, 178-1307, 192-7634,
192-9013, 199-7942, and 208-5845

L5E1-Up (Machine)

L5J1-Up (Machine)

L5N1-Up (Machine)



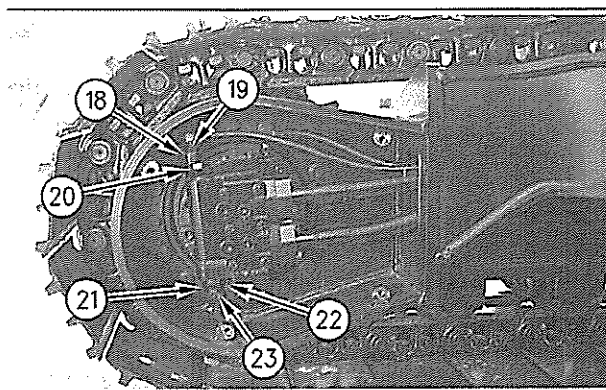

Illustration 9 g00341415

Travel brake valve (left side)

- (18) Locknut
- (19) Adjustment screw
- (20) Crossover relief valve (forward left travel)
- (21) Crossover relief valve (reverse left travel)
- (22) Locknut
- (23) Adjustment screw

6. Place stopper (17) in sprocket (16) in order to block forward left travel. Refer to Illustration 8.

Diameter of stopper 65 to 70 mm
(2.56 to 2.76 inch)

7. Start the engine.
8. Increase the hydraulic oil temperature to $55^{\circ} \pm 5^{\circ}\text{C}$ ($131^{\circ} \pm 9^{\circ}\text{F}$).

Test and Adjust

Forward Travel

1. Slowly move the left travel control lever to full FORWARD position and check the pressure gauge reading at pressure tap (3). The pressure setting of crossover relief valve (20) should be 36800 ± 1470 kPa (5350 ± 215 psi).
2. Return the left travel control lever to the NEUTRAL position.
3. In order to adjust crossover relief valve (20), loosen locknut (18) and turn adjustment screw (19) until the pressure gauge reading at pressure tap (3) is 36800 ± 1470 kPa (5350 ± 215 psi).
4. Tighten locknut (18) to a torque of 130 ± 13 N·m (95 ± 10 lb ft).

Note: Always make final pressure adjustments on pressure rise.

Reverse Travel

1. Place stopper (17) in sprocket (16) in order to block reverse left travel.

2. Slowly move the left travel control lever to full REVERSE position and check the pressure gauge reading at pressure tap (3). The pressure setting of crossover relief valve (21) should be 36800 ± 1470 kPa (5350 ± 215 psi).
3. Return the left travel control lever to the NEUTRAL position.
4. In order to adjust crossover relief valve (21), loosen locknut (22) and turn adjustment screw (23) until the pressure gauge reading at pressure tap (3) is 36800 ± 1470 kPa (5350 ± 215 psi).
5. Tighten locknut (22) to a torque of 130 ± 13 N·m (95 ± 10 lb ft).

Note: Always make final pressure adjustments on pressure rise.

Type “B” Travel Motor (Right)

In order to adjust the crossover relief valves on the right travel motor, place stopper (17) in the sprocket for the right travel motor. Use pressure gauge (2) in order to monitor the crossover relief valve pressure settings for the right travel motor. Adjust the crossover relief valves on the right travel motor in the same manner as the adjustment for the left travel motor.

Note: Return the main relief valve pressure to the specified setting after crossover relief valve pressure setting is attained.

i01337032

Hydraulic System Pressure - Release

SMCS Code: 5050-553-PX

Procedure for Releasing Pressure

Release the pressure in the travel circuits before any hydraulic lines or components are disconnected or removed from the travel circuit.

1. Park the machine on a flat, level surface.
2. Lower all the implements as flat on the ground as possible.
3. Stop the engine.
4. Turn the engine start switch to the ON position without starting the engine.
5. In order to relieve any pressure that might be present in the pilot system, move the implement control and travel control levers or pedals to FULL STROKE positions.
6. Turn the engine start switch to the OFF position.
7. Slowly loosen the fill/vent plug on the hydraulic oil tank and release the pressure.
8. Tighten the fill/vent plug on the hydraulic tank.
9. The pressure in the system should now be released. The hydraulic lines and/or hydraulic components can now be removed.

i01641986

Track Carrier Roller - Remove

SMCS Code: 4154-011

Removal Procedure

Table 2

Required Tools			
Tool	Part Number	Part Description	Qty
(A)	BT - 5255	Hydraulic Jack	1

1. Start the engine. Park the machine on a hard, level surface. Shut off the engine.



WARNING

Personal injury or death can result from grease and oil coming out of the relief valve.

Grease and oil are under high pressure coming out of the relief valve and can penetrate the body.

Do not watch the relief valve to see if grease is escaping. Watch the track or track adjustment cylinder to see if the track is being loosened.

Make sure the vent holes are clean before the tension is released on the track.



Illustration 16

g00489342

2. Release the tension on the track.
3. Loosen relief valve (1) by one turn only. If the track does not loosen after opening the relief valve, move the machine forward and backward until the tension is released.

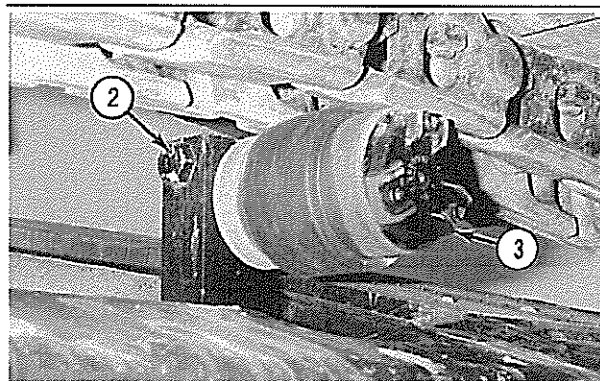

Illustration 17

g00693935

4. Loosen bolt (2) that holds track carrier roller (3) to the mounting bracket on the undercarriage.

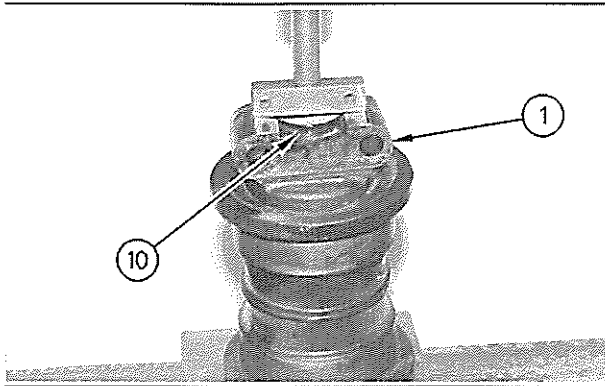

Illustration 49 g00738160

3. Put the track roller in a press, as shown. The weight of the track roller is 29 kg (64 lb).
4. Press downward on end collar (1). Remove snap ring (10).
5. Release the pressure on the end collar. Remove end collar (1).
6. Remove plug (14) from the inside of the track roller.

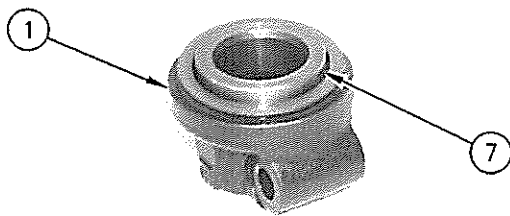

Illustration 50 g00738161

7. Remove Duo-Cone seal (7) from end collar (1).

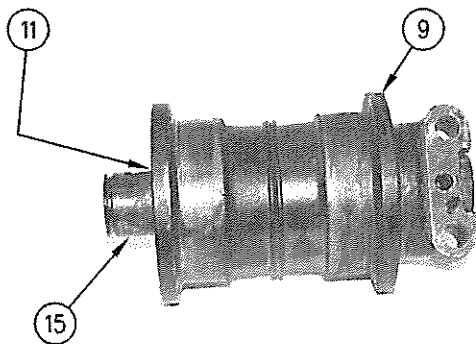

Illustration 51 g00738163

8. Remove O-ring seal (11) from shaft (15). Remove shaft (15) from roller (9).

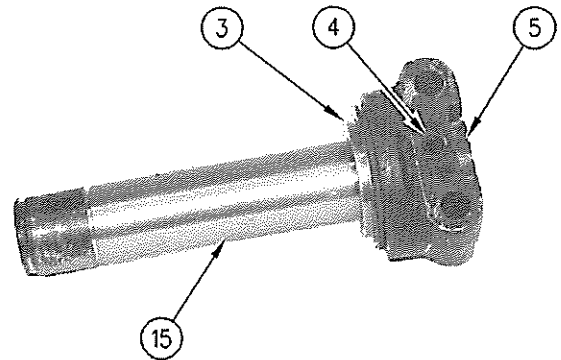

Illustration 52 g00738164

9. Remove Duo-Cone seal (3) from end collar (5).
10. Remove spring pin (4) from end collar (5) and shaft (15).
11. Use a press to remove shaft (15) from end collar (5).
12. Remove O-ring seal (16) from shaft (15). Remove stopper (13) from the end of the shaft.

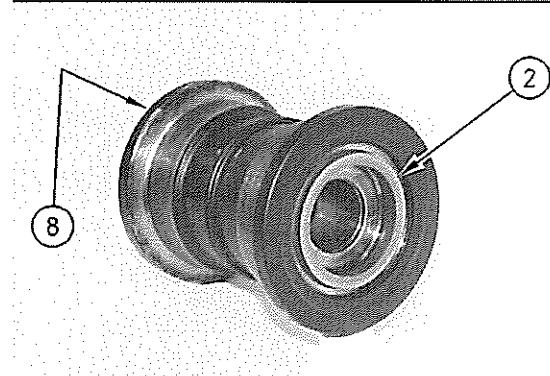

Illustration 53 g00738165

13. Remove Duo-Cone seals (2) and (8) from each end of the track roller.

101642485

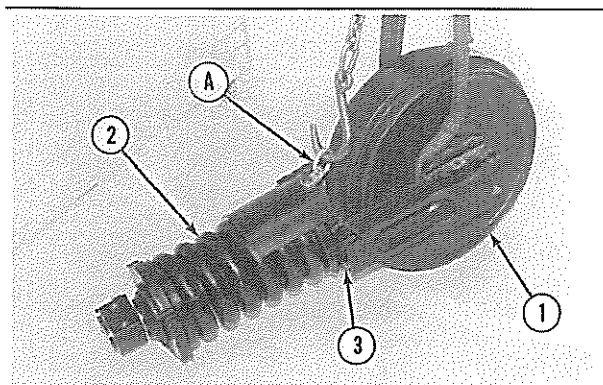

Illustration 79

g00368999

2. Fasten a hoist to the recoil spring and the hydraulic track adjuster. Put the unit in position on the front idler. Temporarily install four bolts (3) that hold the unit together.
3. Install Tooling (A) on the front support for the recoil spring. Fasten a hoist to the front idler and Tooling (A).

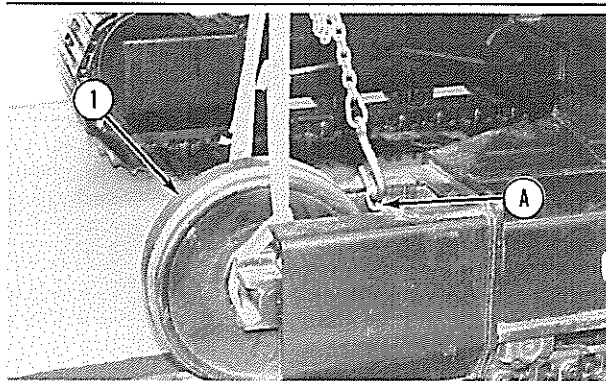

Illustration 80

g00483037

4. Partially slide the front idler, the recoil spring and the hydraulic track adjuster into the undercarriage frame. Leave bolts (3) exposed. Remove the hoist from the unit. Remove Tooling (A) from the unit. Tighten bolts (3).
5. Install the mounting bolt that holds the cover to the front of the recoil spring assembly.
6. Use a pry bar to slide the front idler into the undercarriage frame.

End By:

- a. Connect the track assemblies. Refer to Disassembly and Assembly, "Track - Connect" in this manual.

Front Idler - Disassemble

SMCS Code: 4159-015

Disassembly Procedure**Start By:**

- a. Remove the front idler, the recoil spring, and the hydraulic track adjuster as a unit. Refer to Disassembly and Assembly, "Front Idler, Recoil Spring and Hydraulic Track Adjuster - Remove and Install" in this manual.

1. Thoroughly clean the outside of the front idler prior to disassembly.

NOTICE

Care must be taken to ensure that fluids are contained during performance of inspection, maintenance, testing, adjusting and repair of the product. Be prepared to collect the fluid with suitable containers before opening any compartment or disassembling any component containing fluids.

Refer to Special Publication, NENG2500, "Caterpillar Tools and Shop Products Guide" for tools and supplies suitable to collect and contain fluids on Caterpillar products.

Dispose of all fluids according to local regulations and mandates.

2. Remove the fill/drain plug from the front idler. Drain the oil from the idler into a suitable container for disposal. The capacity of the idler is 180 mL (6.12 oz).

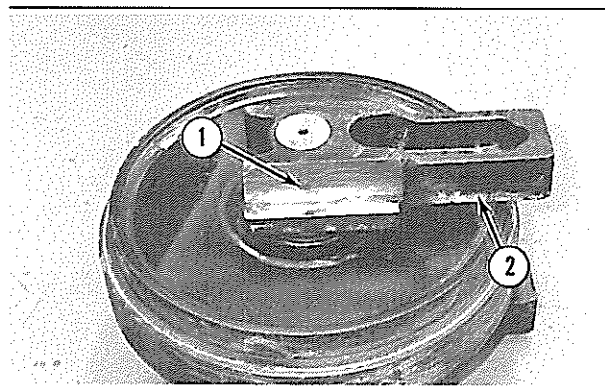

Illustration 81

g00494526

3. Place the front idler on the idler's side, as shown. The weight of the front idler is 109 kg (240 lb).
4. Remove two spring pins (1) from bearings (2).

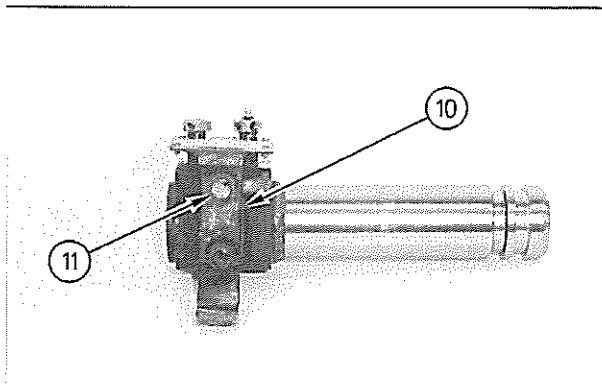

Illustration 115

g00526454

4. Install plate (10). Install two bolts (11) which secure plate (10).

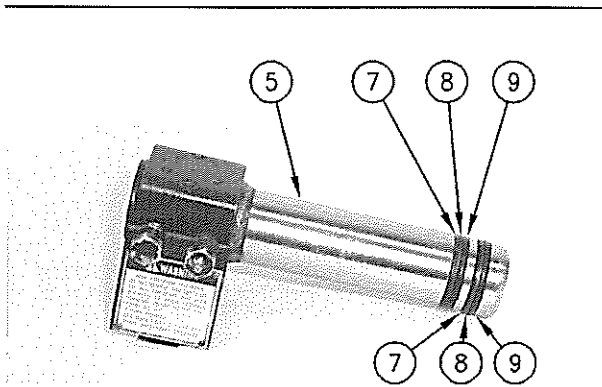

Illustration 116

g00526453

Note: Completely fill the seal grooves in the piston assembly with 5P-0960 Molybdenum Grease. The grease will displace air when the O-rings and the backup rings are installed.

5. Install two backup rings (7), two backup rings (8) and two O-ring seals (9) on piston assembly (5).

Note: O-rings and backup rings must be installed in the correct position in order to ensure the correct operation of the hydraulic track adjuster. Backup rings are distinguished by the color of the ring. Backup rings (7) are black in color. Backup rings (8) are brown in color.

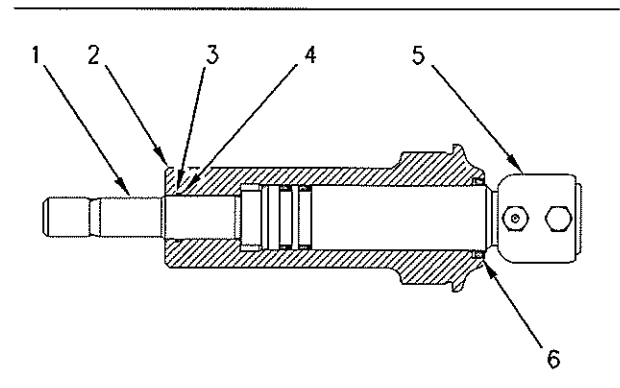

Illustration 117

g00526451

Note: Completely fill the seal groove for O-ring (3) and backup ring (4) in cylinder (2) with 5P-0960 Molybdenum Grease. The grease will displace air when the O-ring and the backup ring are installed.

6. Install O-ring (3) and backup ring (4) in cylinder (2).
7. Apply 5P-0960 Molybdenum Grease in the groove for lip seal (6). Use Tooling (A) to install lip seal (6). Install lip seal (6) until the seal is 0.5 ± 0.5 mm ($.02 \pm .02$ inch) below the surface of cylinder (2). Install lip seal (6) with the lip toward the outside of cylinder (2).
8. Check the condition of the threads on rod (1). If the threads are damaged or worn, replace rod (1) with a new part. Put a small amount of 5P-0960 Molybdenum Grease on the sliding surface of rod (1). Install rod (1) in cylinder (2).
9. Fill the cavity of cylinder (2) with 5P-0960 Molybdenum Grease.
10. Put a small amount of 5P-0960 Molybdenum Grease on the sliding surface of piston assembly (5). Put a minimum of 60 cc (4 in³) of 5P-0960 Molybdenum Grease on the end of piston assembly (5). This grease will prevent air from displacing grease in the cylinder during the installation of the piston. Make sure that the grease covers backup rings (7) and (8) and O-ring (9).
11. Center piston assembly (5) in cylinder (2). Insert the piston assembly into the cylinder.

Note: It may be necessary to use a soft faced hammer to install the piston assembly into the cylinder.

12. Make sure that grease is expelled from the vent hole for the relief valve. Tighten relief valve (12) to a torque of 34 ± 5 N·m (25 ± 4 lb ft).

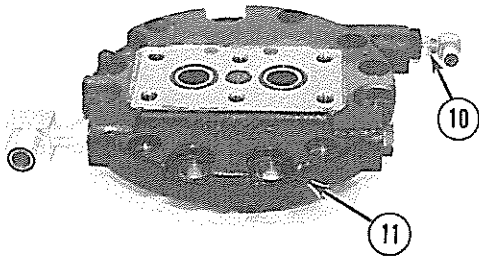

Illustration 142 g00510351

10. Remove three fittings (10) and plugs (11) from the head. Remove the O-ring seal from each fitting.

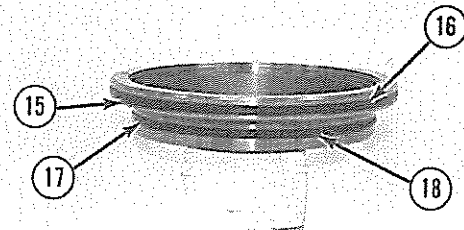

Illustration 144 g00510353

13. Remove O-ring seal (15) from the brake piston. Remove backup ring (16) from the brake piston.
14. Remove O-ring seal (17) from the brake piston. Remove backup ring (18) from the brake piston.

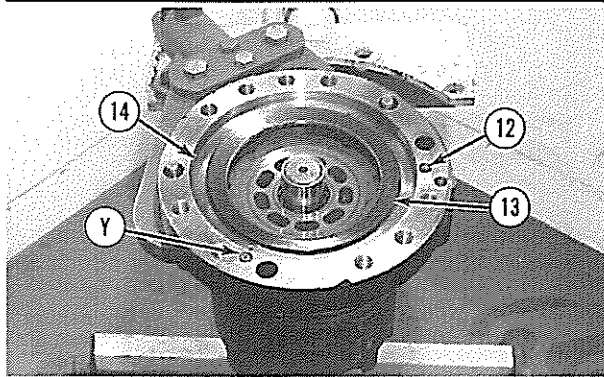

Illustration 143 g00510352

11. Remove three O-ring seals (12) and washer set (13) from the body of the travel motor.
12. Place a shop towel over brake piston (14). Retain brake piston (14) by hand, and apply approximately 525 kPa (75 psi) of shop air pressure to brake release port (Y). Make sure that the shop air pressure is free of water. Brake piston (14) will move up the piston guide, and out of the piston guide. Remove brake piston (14) from the body of the travel motor.

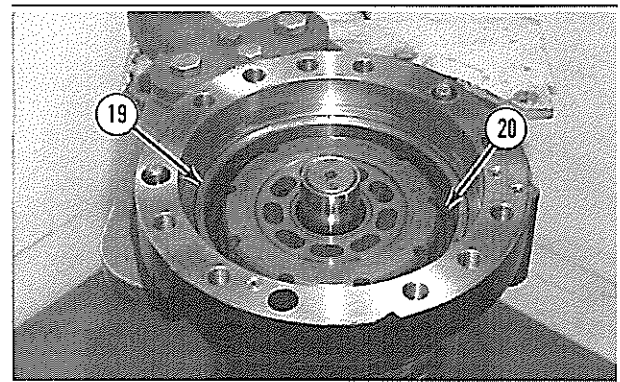

Illustration 145 g00510356

15. Remove piston guide (19), five friction plates (20) and the four steel plates from the body of the travel motor.

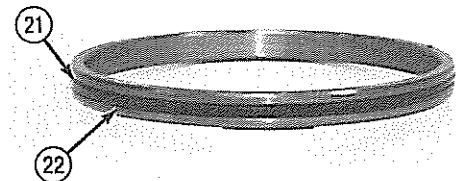

Illustration 146 g00510359

16. Remove O-ring seal (21) from the piston guide. Remove backup ring (22) from the piston guide.

CLICK HERE TO **DOWNLOAD** THE COMPLETE MANUAL

- Thank you very much for reading the preview of the manual.
- You can download the complete manual from: www.heydownloads.com by clicking the link below



- Please note: If there is no response to CLICKING the link, please download this PDF first and then click on it.

CLICK HERE TO **DOWNLOAD** THE COMPLETE MANUAL

Note: When two tube assemblies (3) are disconnected from the travel brake valve, oil will flow from the tube assemblies. Oil will also flow from two hose assemblies (4) and (5) when the hose assemblies are disconnected from the travel motor. Place a suitable container under the tube assemblies and under the hose assemblies in order to collect the oil.

3. Disconnect two tube assemblies (3) from the travel brake valve. Disconnect hose assemblies (4) and (5) from the travel motor. Put plugs in the ends of the tube assemblies and in the ends of the hose assemblies in order to prevent oil loss and keep contaminants out of the hydraulic system.

4. Remove elbow (6) from the travel motor.

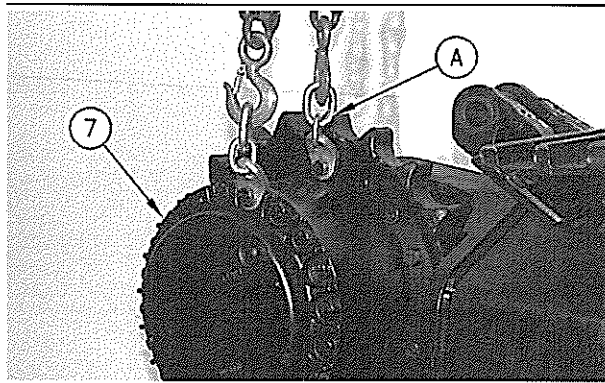

Illustration 181 g00486987

5. Fasten Tooling (A) and a hoist to final drive (7), as shown. Put a slight lifting tension on the final drive.

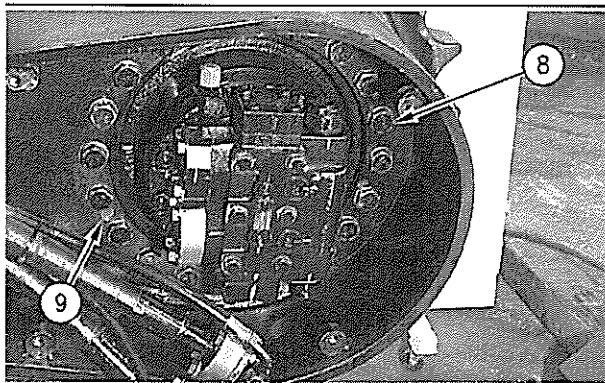

Illustration 182 g00486988

6. Remove two plugs (9) from the forcing bolt holes in the undercarriage frame assembly.

7. Remove 20 bolts (8) and the washers that secure the final drive to the undercarriage frame assembly.

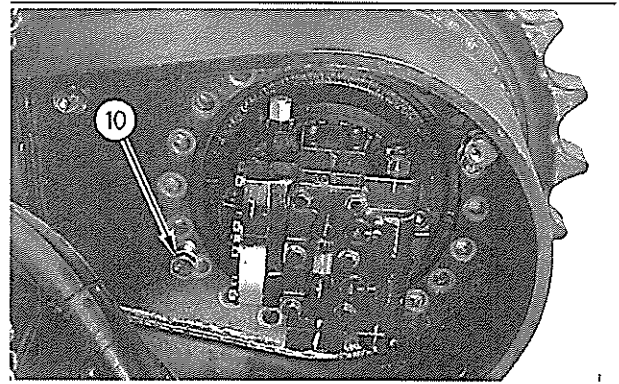

Illustration 183 g00486990

8. Install two suitable sized forcing bolts (10) in the forcing bolt holes in the frame. Tighten the two forcing bolts evenly in order to loosen the final drive from the undercarriage frame assembly.

9. Carefully remove final drive (7) from the undercarriage frame assembly. The combined weight of the final drive and the travel motor is approximately 449 kg (990 lb).

10. Remove two forcing bolts (10) from the undercarriage frame assembly.

11. Remove the travel motor from the final drive. Refer to Disassembly and Assembly, "Travel Motor - Remove" in this manual.

Type "B" Final Drive

Table 21

Required Tools			
Tool	Part Number	Part Description	Qty
(A)	8S-7640	Stand	2
	8S-7611	Tube	2
	8S-7615	Pin	2
(B)	138-7574	Link Bracket	2
(C)	154-6184	Forcing Bolt (M 20)	2

Start By:

- Separate the track assembly. Refer to Disassembly and Assembly, "Track - Separate" in this manual.
- Remove the travel motor. Refer to Disassembly and Assembly, "Travel Motor - Remove" in this manual.

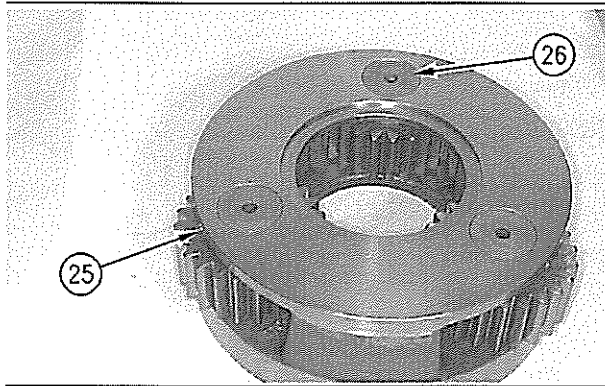

Illustration 225
Typical example
g00511799

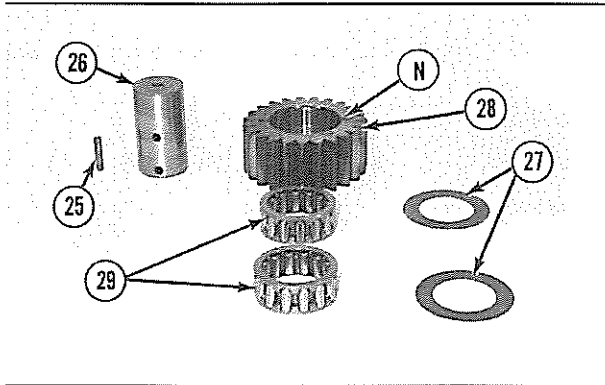

Illustration 226
g00572382

Note: If spring pin (25) is recessed below the outside surface of the carrier, measure the depth of the spring pin and record this measurement for assembly purposes.

21. Drive spring pin (25) into planetary shaft (26) with a hammer and a punch.

Note: Planetary gears (28) might have oil grooves "N". Note the position of the oil grooves in relation to the carrier for assembly purposes.

22. Remove planetary shaft (26), two thrust washers (27) and planetary gear (28) from the carrier. Remove two bearings (29) from the planetary gear. Drive spring pin (25) out of planetary shaft (26) with a hammer and a punch.

23. Repeat Steps 21 and 22 in order to remove the other planetary gears from the carrier.

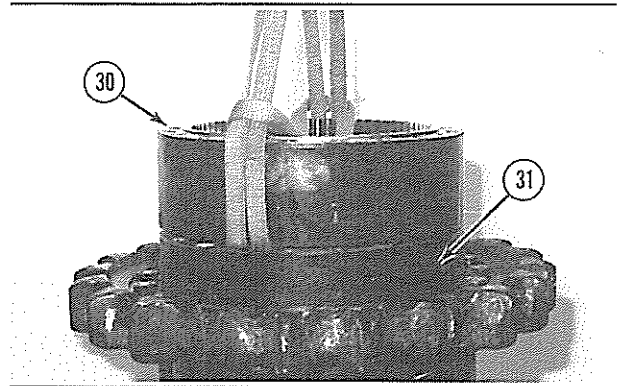

Illustration 227
g00511809

Note: It will be necessary to pry ring gear (30) away from main housing (31) in order to install the lifting slings.

24. Fasten lifting slings and a hoist to ring gear (30), as shown. Remove the ring gear from main housing (31). The weight of the ring gear is 48 kg (105 lb).

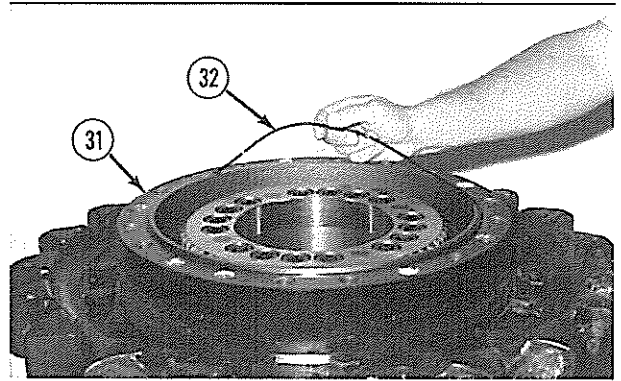

Illustration 228
g00511825

25. Remove O-ring seal (32) from main housing (31).

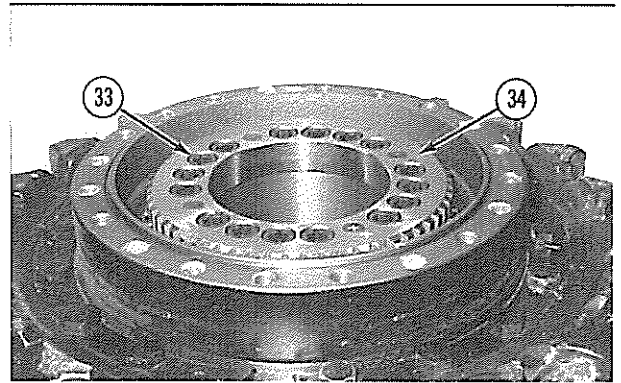

Illustration 229
Typical example
g00511857

5. Remove the main housing from the motor housing.

Note: The rubber seals and all surfaces that contact the seals must be clean and dry. After installation of the seals, apply clean SAE 30 oil on the contact surfaces of the metal seals. For more information concerning the assembly and installation of Duo-Cone Seal kits, refer to Disassembly and Assembly, "Duo-Cone Conventional Seals - Install" in this manual.

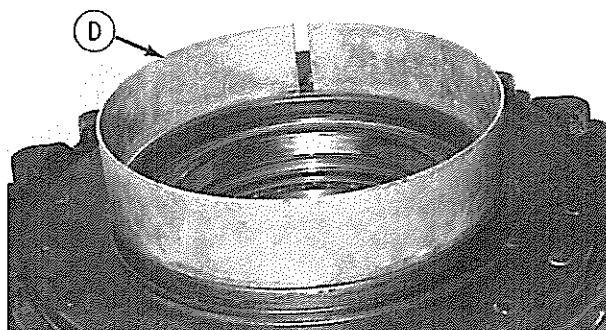

Illustration 269

g00513401

6. Install Duo-Cone seal (37) in the main housing with Tool (D).

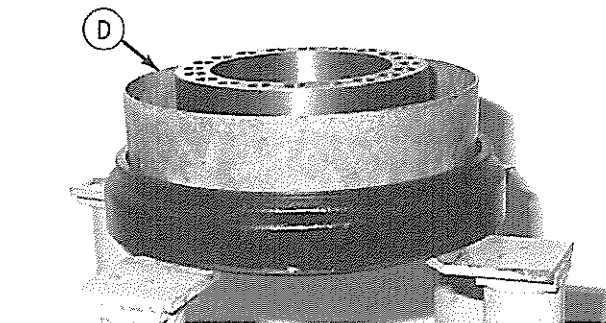

Illustration 270

g00513424

7. Install Duo-Cone seal (36) in the motor casing with Tool (D).

Note: Make sure that the Duo-Cone seals are not scratched or damaged during the assembly of the main housing or during the assembly of the motor housing. After installation of the main housing on the motor housing, there will be a small gap between the components. The gap is caused by the Duo-Cone seals. The gap will be eliminated during installation of gear (34).

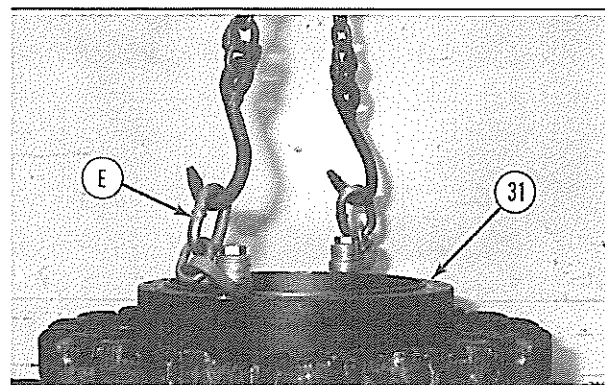

Illustration 271

g00511882

8. Fasten Tooling (E) and a hoist to main housing (31). Place the main housing and the final drive sprocket in position on the motor housing. Make sure that the Duo-Cone seals are not scratched or damaged during installation.

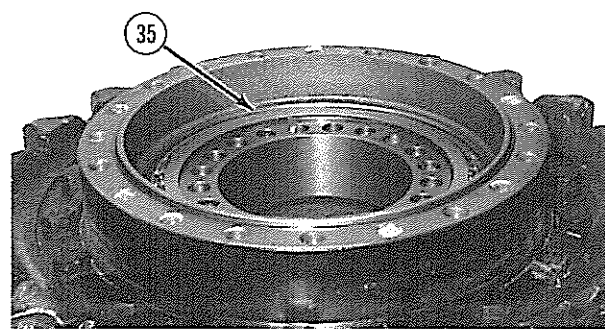

Illustration 272

g00511872

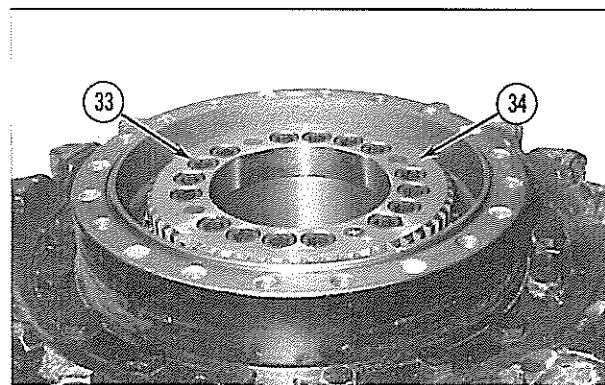

Illustration 273

g00511857

9. Apply 5P-3931 Anti-Seize Compound on the four pins in gear (34).
10. Place shim pack (35), which was determined in Step 4.a through 4.g, and gear (34) in the correct position on the motor housing. If two shims were required, put the thinner shim in contact with gear (34). Make sure that all of the holes in the components are in alignment with each other.

i01651107

Swivel - Disassemble

SMCS Code: 5060-015

Disassembly Procedure

Start By:

- a. Remove the swivel joint. Refer to Disassembly and Assembly, "Swivel - Remove" in this manual.

NOTICE

Care must be taken to ensure that fluids are contained during performance of inspection, maintenance, testing, adjusting and repair of the product. Be prepared to collect the fluid with suitable containers before opening any compartment or disassembling any component containing fluids.

Refer to Special Publication, NENG2500, "Caterpillar Tools and Shop Products Guide" for tools and supplies suitable to collect and contain fluids on Caterpillar products.

Dispose of all fluids according to local regulations and mandates.

1. Thoroughly clean the outside of the swivel joint prior to disassembly.

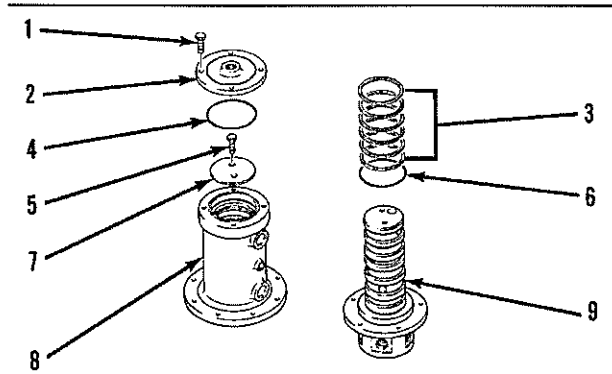

Illustration 307

g00515028

2. Remove four bolts (1) and cover (2) from outside housing (8). Remove O-ring seal (4) from outside housing (8).
3. Remove two bolts (5), the washers and retainer (7) from rotor (9). Remove outside housing (8) from rotor (9).
4. Turn the outside housing upside-down and remove O-ring seals (6) and seals (3) from the outside housing.

i01651160

Swivel - Assemble

SMCS Code: 5060-016

Assembly Procedure

1. Make sure that all of the parts of the swivel joint are thoroughly clean and free of dirt and debris.

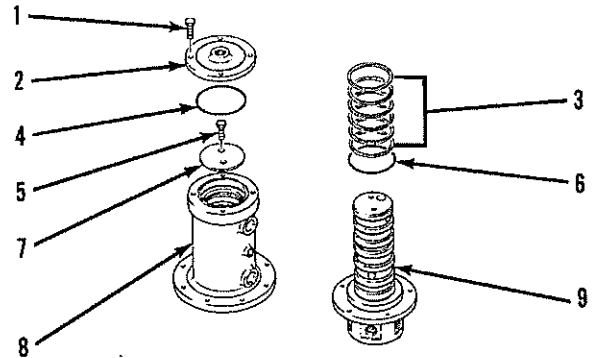

Illustration 308

g00515028

2. Check the condition of seals (3) and O-ring seals (6). If the seals or O-ring seals are worn or damaged, use new parts for replacement.
3. Install seals (3) and O-ring seals (6) in outside housing (8). Put clean hydraulic oil on seals (3) and O-ring seals (6).
4. Install outside housing (8) over rotor (9). Install retainer (7), two bolts (5) and the washers that secure the retainer.
5. Check the condition of O-ring seal (4). If the O-ring seal is damaged, use a new part for replacement.
6. Apply clean hydraulic oil on O-ring seal (4). Install the O-ring seal in the outside housing.
7. Install cover (2) and four bolts (1) that secure the cover.
8. Check the swivel joint for leaks. Plug the drain ports of the inside body. Apply shop air pressure in the top of the swivel joint and check the swivel joint for leaks.

End By:

- a. Install the swivel joint. Refer to Disassembly and Assembly, "Swivel - Install" in this manual.

4.1.4 Feed Chain Block

Periodic inspection of the feed chain, idlers, and pins are required as shown in Fig 4.1.7.
INSPECT EVERY 250 HOURS UNLES NOTED.

Refer to Fig. 4.1.7

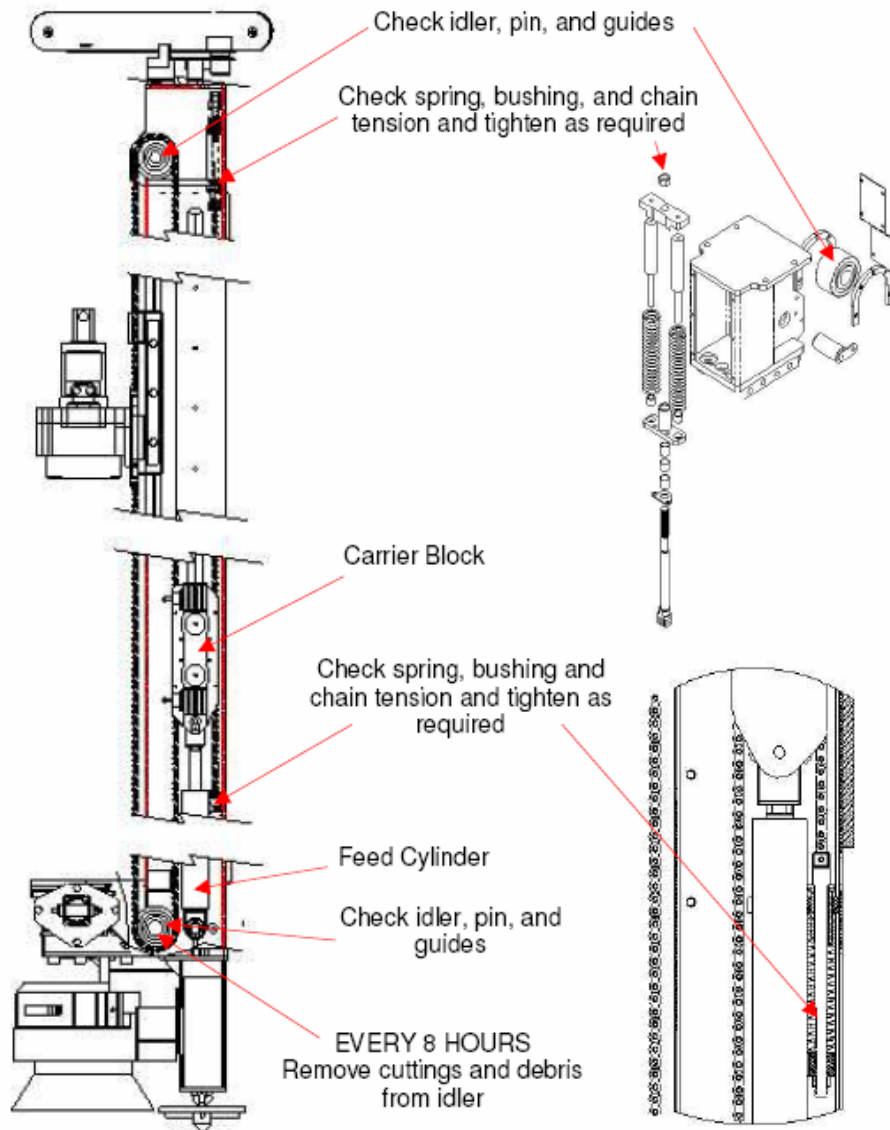

Fig 4.1.7 Feed Chain Block

4.2.6 Driveshaft Assembly and Installation

Begin assembly of the driveshaft in the upright position.

Refer to Fig 4.2.7 to Fig 4.2.22

1. Install the top spacer. Refer to Fig 4.2.7



Fig 4.2.7

2. Using a bearing warmer, heat one bearing cone to between 250-300°F (120-150°C) (refer to Fig 4.2.8).



Fig 4.2.8

4.2.9 Installing Air Swivel and Hydraulic Motors

1. Install swivel o-ring on the driveshaft and lubricate (see Fig 4.2.30).



Fig 4.2.30

2. Apply anti-seize to the threads of the swivel and install onto the driveshaft (see Fig 4.2.31), tightening by hand only.

NOTE: swivel in picture is left hand thread, RB30 is right hand thread.

When Top Drive is installed, follow proper tightening instructions, given in section 4.2.11.



Fig 4.2.31

4.2.11.4 Inspection of Parts

1. Inspect housing for wear, scoring, cracks, burrs, and thread condition. If any cracks are found, the housing must be replaced.
2. Inspect large tube for wear on the sealing area and the snap ring groove for damage. If wear is present or snap ring groove is damaged, the large tube should be replaced.
3. Inspect small tube for wear on sealing area and thread damage.
4. Inspect wear sleeve for wear in the sealing area.
5. Inspect seal retainer for cracks and damage. Punch marks on the bottom from disassembly can be lightly buffed off. If any cracks are found, the retainer must be replaced.
6. Inspect housing cap for wear, and damage in the seal groove.

NOTE: All seals and bearings should be replaced at time of rebuild.

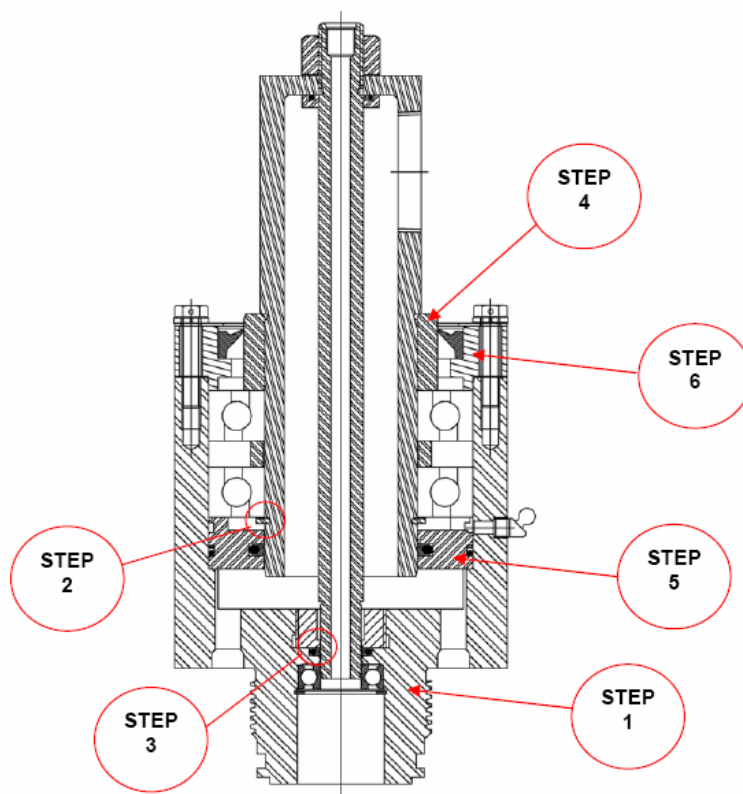

Fig 4.2.46

Carousel Inspection at 250 Hours

1. Inspect top wear liner.
2. Inspect washers for wear.
3. Inspect bearings.
4. Inspect cylinder pins and clamp pins.
5. Inspect bushings inside clamp and washers.
6. Inspect cylinder bearing.
7. Repeat steps 4 and 6.
8. Repeat steps 2 and three.
9. Inspect bottom wear liner.

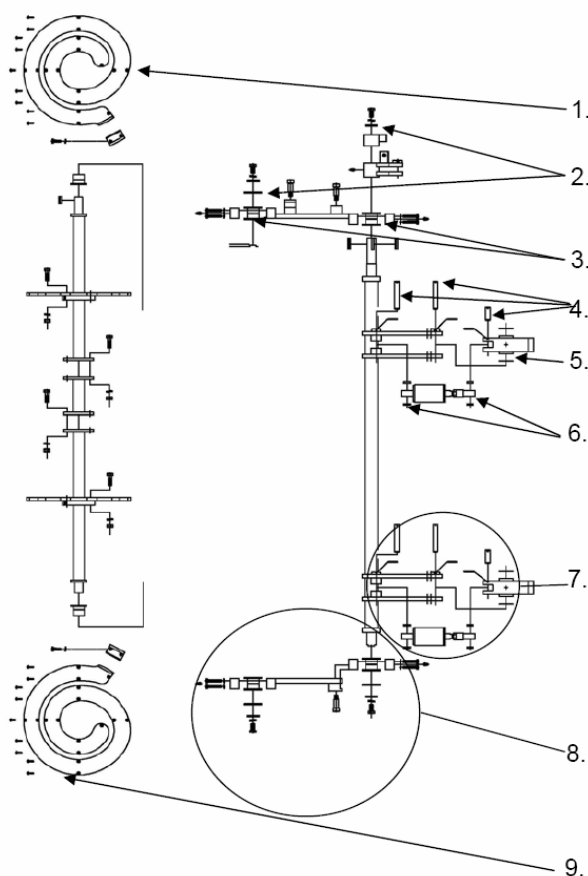

Fig 4.3.2 Carousel Inspection

5.3 Hydraulic Pump

This model of pump is designed for open-loop, closed center, or load-sensing hydraulic systems. Flow is proportional to the drive speed and the displacement. By adjusting the position of the swashplate it is possible to smoothly vary the flow.

The “Load Sense” type of control registers the load at a point away from the pump. In the case of your Cubex drill, a pilot line from the hydraulic control valves sends the pressure signal back to the pump. The pump control then tries to keep the output pressure above the load requirements by the standby or differential pressure (Pressure Compensation). The differential pressure is generally in the area of 400 PSI.

Principals of Operation

The displacement mechanism of this series of pumps operates via two stroking pistons (large and small) which adjust the position of the swashplate. The smaller of the two stroking pistons (1) works in conjunction with its spring (2) to always try to move the swashplate to maximum angle and therefore the pump to maximum displacement. High-pressure oil is continually routed from the outlet (pressure) port to the small stroking piston via the control oil drilling (3). Working in opposition to this on the opposite of the swashplate is the larger stroking piston (4). If pressurized fluid is routed to the larger stroking piston (4) it will exert a force to de-stroke the pump to a lower displacement value. Since piston (4) has a larger area than piston (1) the pump will de-stroke with pressure on both cylinders. It is therefore possible to control the pump displacement by changing the pressure applied to the larger of the two stroking pistons. All of the pump controls work on the same principal of controlling the pressure on this large stroking piston (4) in order to vary the pumps displacement.

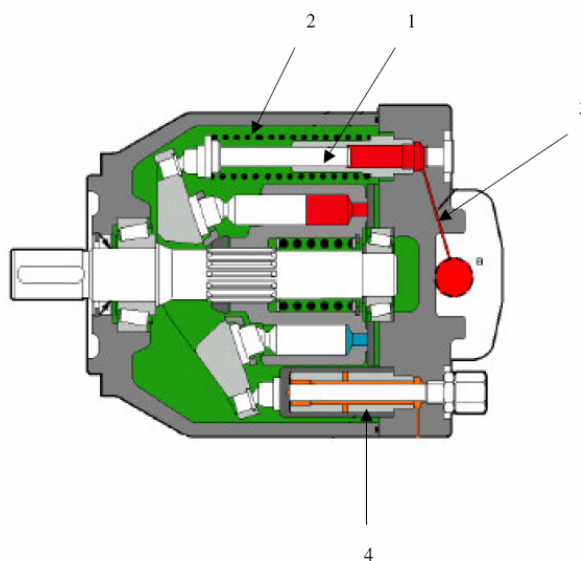

Fig 5.3.1 Hydraulic Pump

5.3.5.5 Cavitation/Aeration

Cavitation results when air, which is typically entrained or dissolved in the hydraulic fluid, is allowed to expand because of a low-pressure situation. This occurs in pump inlets, which by nature have a low-pressure condition. The expanded gas bubbles at the inlet collapse with considerable force as the pumping chamber is exposed to system pressure. This collapsing action results in rapid energy losses in the form of heat and noise. This energy level is also high enough to cause serious damage to the lens plate and/or the cylinder barrel of the pump.

Aeration is somewhat different than cavitation, however the resulting noise and damage to the pump is nearly identical. Aeration occurs when there are air bubbles present in the reservoir fluid at atmospheric pressure (typically caused by excessive foaming or vortexing at the pump inlet). These air bubbles are then drawn into the inlet line of the pump and ultimately cause of the same damage as described above.

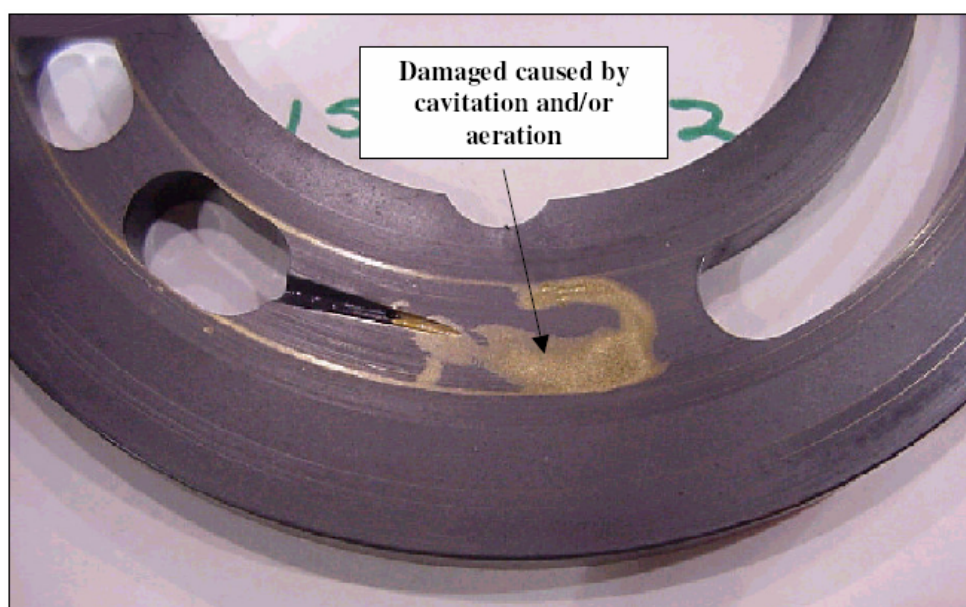
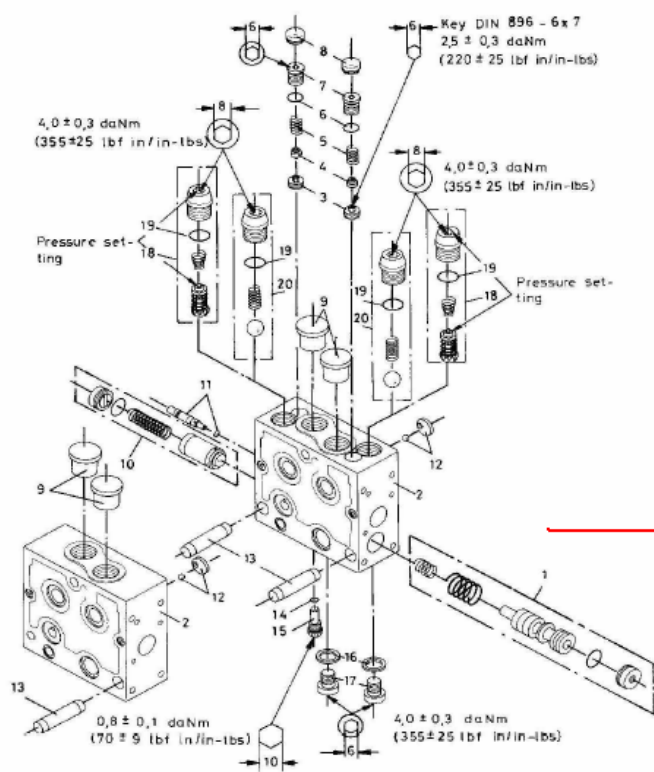

Fig 5.3.7 Cavitation / Aeration



Note: Illustration may show more parts than your valve contains

Fig 5.5.6 - Valve Assembly

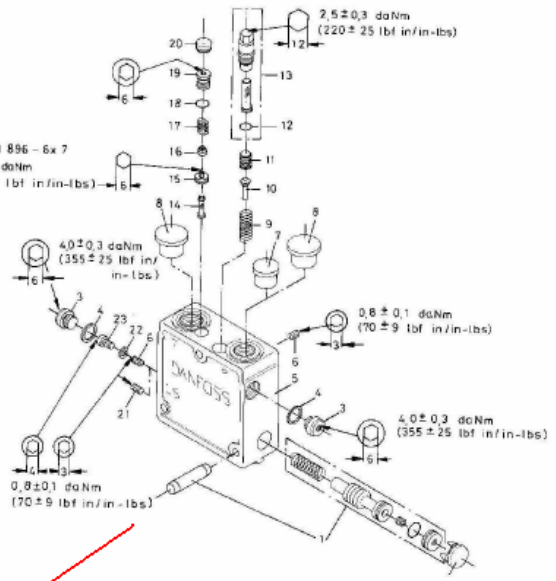

Fig 5.5.7 - Inlet Section

5.9 Proportional Valves

Proportional load-sensing type valves are used where variable flow is required. Refer to the Troubleshooting Section and Electrical Section when determining operating problems.

PM Tasks

Periodic maintenance is limited to external inspections. Overhauling the control valves includes replacing O-rings, seals and setting the pressure and flow. See Proportional Valve Settings below for these specifications. If additional parts need servicing, it may be more economical to replace the individual valve sections.

1000 Hour Intervals: Visual inspection.

2000 Hour Intervals: Visual inspection.

Operate controls to check for proper operation.



WARNING!

After installing hydraulic components and hoses, check that hydraulic actuators are operating in direction as indicated on controls.

CAUTION!

Operating pressure in hydraulic pump must be set correctly before performing this adjustment.

Improper Makeup & Breakout Speed may damage equipment or drill pipes.

All proportional valves are equipped with white/grey connectors.

These instructions apply to proportional valves only.

5.9.1 Proportional Valve Settings

Controls	Valve Type	Flow Rating	Pressure Setting	Flow Setting
Tram, left	Proportional	47.0 gpm (177.9 l)	N/A	Wide open
Tram, right	Proportional	47.0 gpm (177.9 l)	N/A	Wide open
Rotation	Proportional	47.0 gpm (177.9 l)	See Note 1	Wide open
Feed	Proportional	47.0 gpm (177.9 l)	N/A	Wide open
Water Pump	Proportional	10.2 gpm (40.0 l)	N/A	See Note 2

Notes: 1. Forward pressure: 1600 psi (110 bar), Reverse pressure: 2800 psi (193.5 bar). Reverse pressure is much higher than forward pressure to allow for breaking of toll joints.

2. Set flow to run water pump motor at 225 rpm using a tachometer.

6.2.2 Compressor Discharge System Functional Description

The Sullair compressor unit discharges a compressed air/fluid mixture into the sump. The discharge valve is located on the compressor unit at the end opposite the drive shaft. The discharge check valve prevents discharged air from returning from the compression chamber or sump on shut down.

From the discharge valve the air/fluid mixture is directed to the sump. The sump has four basic functions:

- Acts as a primary fluid separator.
- Serves as the compressor fluid sump.
- Houses the final fluid separator.
- Serves as an air tank receiver.

The compressed air/fluid mixture enters the sump and is directed against the end of the tank. By change of direction and reduction of velocity, larger droplets of fluid fall to the bottom of the sump. The fractional percentage of fluid remaining in the compressed air collects on the surface of the final separator element as the compressed air flows through the separator. As more and more fluid collects in the element surface, the fluid descends to the bottom of the separator. A return line (or scavenger tube) leads from the bottom of the separator element to the gear case of the compressor unit. Fluid collecting on the bottom of the separator unit is returned to the compressor gear case. An orifice (protected by a strainer) is included in this return line to assure proper flow.

The sump is ASME code rated at 600 PSIG (4137kPa) working pressure. A minimum pressure valve is located downstream from the separator to assure the required minimum receiver pressure during all conditions. This pressure is necessary for proper fluid circulation and air/fluid separation.

The system is protected from excessively high sump pressures by a 550 PSIG (37.69 bar) pressure relief valve, which is located on the wet side of the separator and is vented to atmosphere. Also, a two stage High Compressor Discharge Temperature Shut Down (a warning light comes on at 285° F, the compressor will shut down at 300° F) and High Interstage Temperature Shut Down (set at 280 deg. F) will shut the compressor unit down if the temperature exceeds the normal operating range.

Fluid is added to the sump via a capped fluid filler opening placed low on the tank to prevent overflowing to the sump. A sight glass enables the operator to visually monitor the fluid sump level. The proper level is halfway of the sight glass when the unit is shutdown. **DO NOT OVERFILL.**

A hydraulically operated 2-inch ball valve is used to open and close the discharge air when required.



WARNING! - DO NOT open the fluid filler cap when the compressor is pressurized. Shut down the compressor and bleed the sump to 0 PSIG before removing the cap

6.2.7.2 Butterfly Inlet Valve Functional Description

The purpose of the control system is to regulate the amount of air intake in accordance with the amount of air being used. The 2-stage compressor is designed to operate in one of the three modes of operation: the low-pressure mode up to (180 psig {12.4 bar}) and two high pressure modes (350 psig {24.1 bar}) and (500 psig {34.5 bar}). The control system consists of a 2-stage control (incorporating an inlet control cylinder and a closed inlet cylinder), running blowdown valve, and the necessary linkage to connect the inlet control cylinder to the inlet valve.

The position of the pressure selector determines the pressure that the control system will respond to. The functional description of the control system is described in four distinct phases of operation which (except for the start phase) apply to both high and low pressure modes.

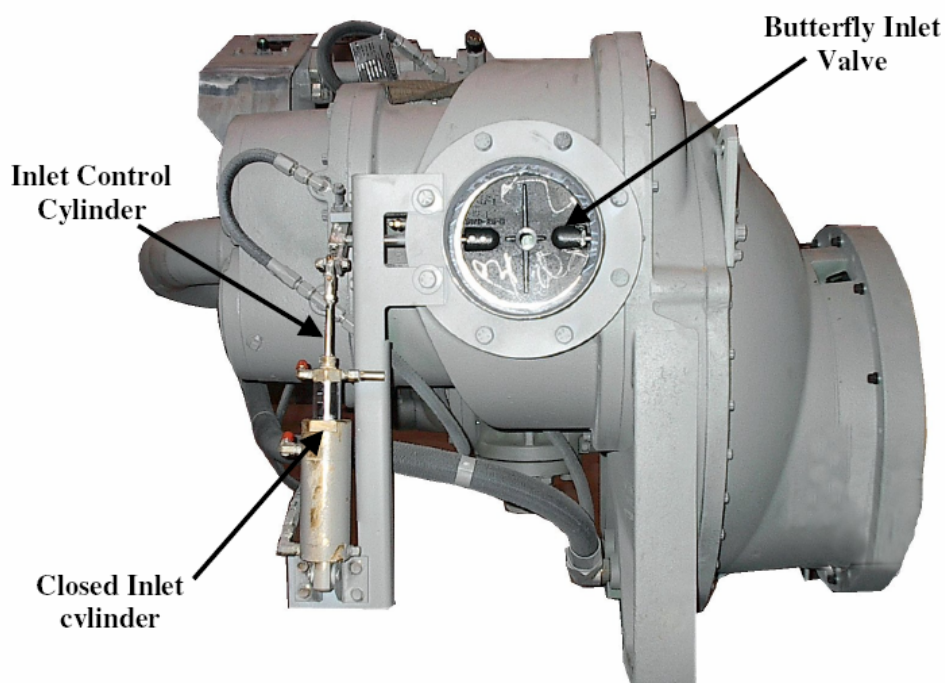

6.2.10 Butterfly Inlet Valve



WARNING: This compressor unit must only be serviced by qualified personnel.

No attempt should be made to alter this unit in any manner without written permission from Cubex. Any alterations may result in serious injury or damage to the unit.

Whenever working on this unit, check that the system has fully bled off before opening any connections. Compressed air has tremendous contained energy, which is released when opened to atmosphere. The potential to cause severe injury or damage is great if proper procedures are not followed.

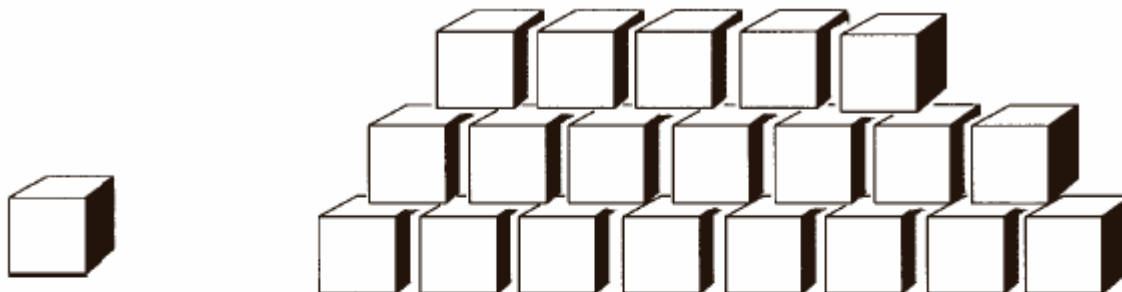

1 cu. ft. of Air
at 350 psi.

Same Volume Released
to Atmospheric Pressure

Warning!

Drain the Air System before Servicing!

6.2.8.8 Safety Valve

The Safety Valve is a non-serviceable item and must be replaced if it fails. If replacement is necessary follow these instructions.

1. Remove the failed unit and replace with new.
2. Apply a small amount of pipe dope to the male threads only of new safety valve.
3. Tighten by hand, then tighten not more than one extra turn using a wrench on the inlet hex nut.

During services it is recommended that the safety valve be cracked open to ensure that it is still functional. If the witness wire has been broken the safety valve must be replaced.

Check the pressure ratings on the safety valve as 400 PSI, 450 PSI, and 550 psi valves are available.



Fig 6.2.37 Safety Valve

6.3 Water Pump

Driven by a hydraulic motor, the water pump is a positive displacement unit. It is equipped with a strainer/pressure regulator in the suction line and a relief valve mounted in the discharge line.

PM Tasks

Visual inspections and changing the crankcase oil are routine maintenance procedures. The hydraulic motor requires lubrication of the drive coupling but no periodic servicing is required. Service instructions are not included because replacing the motor is more economical than overhauling.

250 Hour Intervals: Check pressure regulator/ strainer

1000 Hour Intervals: Change crankcase fluid

2000 Hour Intervals: Perform a pressure test



WARNING! Disconnect electrical power, mine air, water supply, and relieve pressure in air receiver before servicing.

CAUTION! Keep parts separate or mark components to allow installation in original locations.

Drain pump before exposing to freezing conditions.

Technical Specifications:	Volume:	4 gpm (15 l/m) @ 225 rpm
	Discharge pressure:	425 psi (29.4 bar)
	Speed:	225 rpm
	Crankcase Capacity:	40 fl. oz. (1.2 L)
	Lubricant Type:	Shell Tellus T 37 Hydraulic Oil
	Weight:	32 lbs. (14.5 kg.)

Pump Accessories:	Relief Valve:	425 psi (29.4 bar)
-------------------	---------------	--------------------

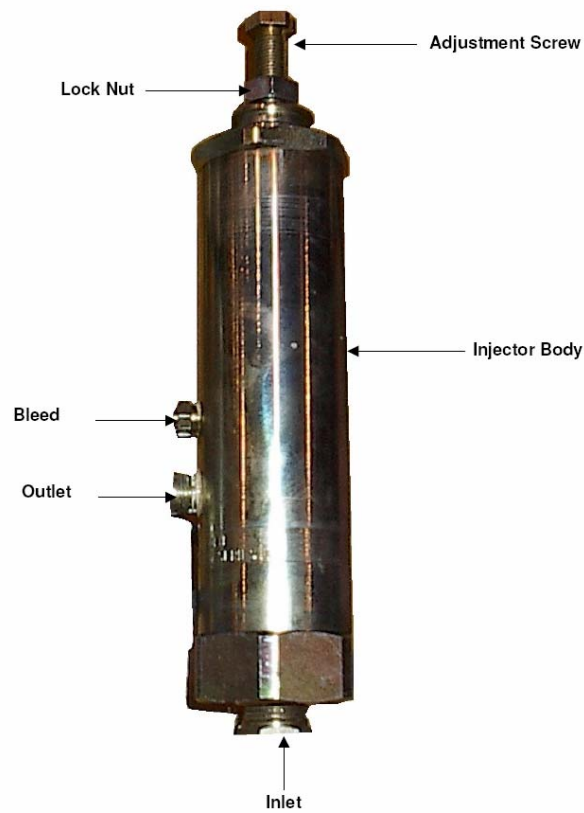

Fig 6.4.4 Adjusting Flow Rate

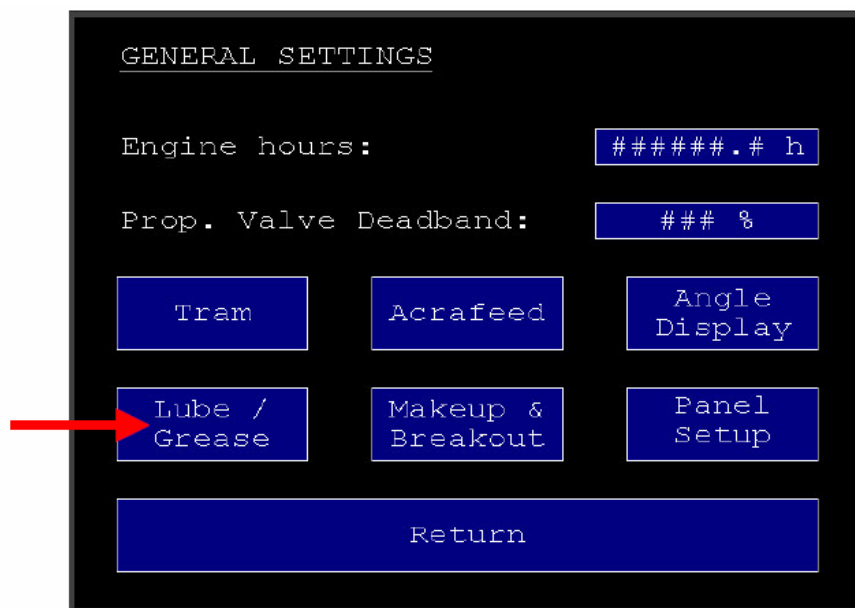

Fig 6.4.5 General Settings screen

Joystick in right position (See Fig 7.8.1):

pin 1:	12 volts DC (100% of supply voltage).
pin 2:	3 volts DC (25% of supply voltage).

Conclusion: If readings match above test, replace the solenoid

If readings do not match, check the following:

- Joystick not travelling to full position
- Faulty joystick
- Faulty wiring
- Improper voltage

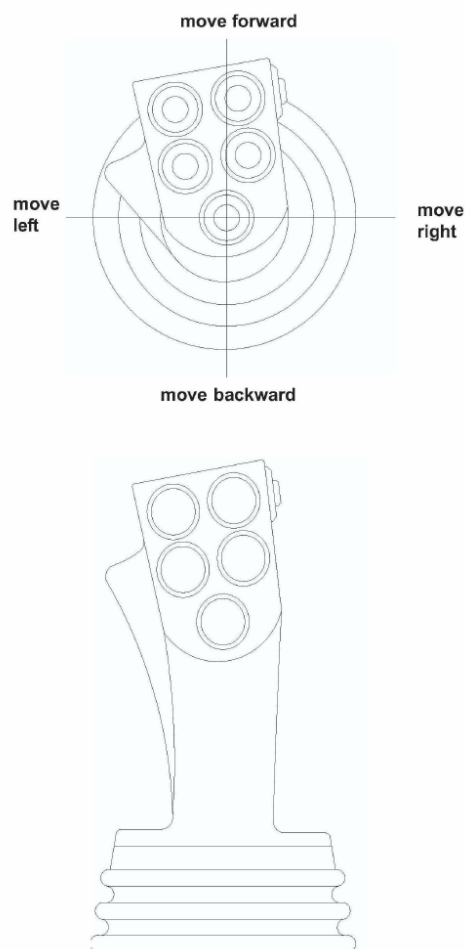

Fig 7.8.1

8.0 TROUBLE SHOOTING



Clean Tools and Equipment!

CLICK HERE TO **DOWNLOAD** THE COMPLETE MANUAL

- Thank you very much for reading the preview of the manual.
- You can download the complete manual from: www.heydownloads.com by clicking the link below



- Please note: If there is no response to CLICKING the link, please download this PDF first and then click on it.

CLICK HERE TO **DOWNLOAD** THE COMPLETE MANUAL