



Model B40i3 Maintenance Manual



LANDOLL CORPORATION

1900 North Street
Marysville, Kansas 66508
(785) 562-5381

800-428-5655 ~ WWW.LANDOLL.COM

CLICK HERE TO **DOWNLOAD** THE COMPLETE MANUAL

- Thank you very much for reading the preview of the manual.
- You can download the complete manual from: www.heydownloads.com by clicking the link below



- Please note: If there is no response to CLICKING the link, please download this PDF first and then click on it.

CLICK HERE TO **DOWNLOAD** THE COMPLETE MANUAL

For your Safety

NOTICE

In the interest of operator safety and in compliance with OSHA regulations, guidelines have been developed for performing service and maintenance on the truck. Before performing service and maintenance on the truck, review the following sections in this manual for additional procedures to be followed.

IMPORTANT

When doing maintenance or repair on the Bendi B40i3 truck, unless the truck must be on for testing, remove the key. In addition, because it's possible to have a duplicate key, remove the main power fuse and disconnect the battery. Also, install a warning reminder on the steering wheel, indicating that the truck is not available for use.

Battery Safety Rules:



CAUTION

- DO NOT bring any type of flame or spark near the battery.
- DO NOT place any electrically conductive tool on the battery that could cause a spark. Gas formed while the battery is charging is highly explosive. This gas remains in the cells long after charging is complete.
- Keep the battery clean. Foreign matter in the electrolyte will result in poor battery performance.
- Follow the battery manufacturer's instructions concerning maintenance and repair.
- The battery must meet size and voltage requirements of the truck.
- Make certain the charger being used matches the voltage and amperage of the truck battery.
- Before connecting or disconnecting the battery to a charger, make sure the charger is OFF. Attempts made to do this while the charger is ON, could result in serious injury to the operator and damage could occur to the charger with sparks or electrical spikes.

Hydraulic System



WARNING

- HIGH PRESSURE FLUIDS ARE DANGEROUS!
- Relieve all pressure from the hydraulic system before attempting to work on it.
- Make sure all hydraulic lines are tight before starting the system. Leaks in the hydraulic system can pierce the skin and cause severe injury. Any fluid injected into the skin under high pressure should be considered a medical emergency despite normal appearance of the skin. Medical attention by a doctor should be administered immediately.

IMPORTANT

When maintenance is to be performed on the hydraulic system, make sure the system hydraulic pressure is relieved by:

- Moving the truck to a level area.
- Have no load on the forks.
- Completely lower the mast, or if the mast is the object of repair, have blocks under the mast.
- Relieve all system pressure by moving the hydraulic levers in each direction several times.

Towing the Truck

NOTE

The Bendi B40i3 truck should be towed in the reverse direction. It is important to obey the following instructions:

1. With ignition off and brake pedal released, locate the brake release pump/valve assembly - notice the red manual control knob. See Figure 1-2. Close the manual valve by pulling up on the handle, rotate the handle 90° remove line and allow the detente cross pin into place.
2. Push and release the manual hand pump 5 to 7 times to build pressure that releases the park brake.
3. The Bendi B40i3 may now be towed a maximum of 200 yards, at a maximum speed of 2 MPH.
4. To reset park brakes, open manual valve by pulling up on the handle and rotate 90°, then locking the detente cross pin into the up (open) position.

To be performed each 2000 hrs of truck operation in addition to the required pre-shift daily inspection.

Continued onto page 1-13 for clarity.

Technicians 2000 Hour Inspection	Status	Landoll / Bendi IC
SAFETY & OPERATIONAL CHECKS Have a qualified technician correct all problems.	OK (X)	Maintenance Note if Applicable
Mast, carriage, or attachment friction surfaces - Clean, inspect for wear or damage and lubricate.		
Mast chains - Lube with SAE 40W oil or Bowman Heavy Load Red grease - Check for wear and stretch.		
Lift chains - Clean and lubricate with SAE 40W oil or Bowman Heavy Load Red grease - Check for wear and stretch.		
Extend mast - Check for excessive wear.		
Attachment control - Operational.		
Accelerator - Functioning smoothly.		
Controls (pwr on); Investigate unusual noises immediately.		
Instrument monitors - Functioning.		
Parking Brake- Functioning.		
Exterior hydraulic tank and oil tank breather - Clean.		
Hydraulic oil and power steering - Clean dust from motors.		
Leaks - Hydraulic oil, battery, brake fluid, transmission.		
Hydraulic hoses and connections - Check for wear.		
Hydraulic oil filter - Change element and oil. Check for proper level - Check pressures.		
Hydraulic reservoir suction screens - Clean with solvent.		
Battery - Thoroughly clean.		
Battery - Check water/electrolyte level.		
Battery - Check structure and electrical conditions.		
Seat belt, buckle, and retractors - Functioning smoothly.		
Tires Check for debris, torque lug nuts to 225 ft-lbs (300Nm).		
Wheel bearings - Clean and fill with grease.		
Vacuum Hoses - Check for cracks and leaks.		
Switches (interlock, direction, parking/seat, key, pressure, and temperature) - Check.		
Wire connections and sending units - Check.		
Grease fittings - Service.		
Forks, top clip retaining pin and heel - Condition.		
Load rollers - No greater than 1/16" play.		
Steering operation - Functioning smoothly; Lube knob.		
Micro Switches - Check operation.		
Operator's compartment capacity plate attached - Information matches model, serial no., and attachments.		
Check all connections for proper torque.		
LPG System - Check pressure hoses and fitting seals.		

IMPORTANT

- It is important that the proper level of oil be maintained at all times. Failure to check the oil level as recommended could cause serious mast function operating problems.
8. Add Hydraulic oil as needed. See page 1-15 for recommended lubricants.
 9. **DO NOT OVERFILL.** With the level above the FULL line, the oil does not have enough area for expansion when it heats up during normal operation.
 10. IF the fluid appears dirty or dark in color, check the truck's maintenance log for the last fluid and filter change and then change accordingly.
 11. Install the fill cap, making sure it is tight.
 12. Close and latch the access assembly and doors.

Check engine oil level

1. Lower the mast to within a few inches of the ground, then tilt it back completely.
2. Open the engine compartment by releasing the latch just under the driver in the front of the compartment. See Figure 2-4.

3. Remove the engine oil dipstick and wipe end with a clean rag.
4. Insert dipstick and remove, observing the oil level.
5. Ensure the oil level is at the proper level as indicated by the marks on the dipstick.
6. Clean the area around the engine fill cap, then open the cap (turn counter clockwise). See Figure 2-6.
 - It is important that the proper level of oil be maintained at all times. Failure to check the oil level as recommended could cause serious problems.
7. Add engine oil as needed. See page 1-15 for recommended lubricants.
8. **DO NOT OVERFILL.** With the level above the FULL line, the oil does not have enough area for expansion when it heats up during normal operation.
9. If the fluid appears dirty or dark in color, check the truck's maintenance log for the last fluid and filter change and then change accordingly.
10. Install the fill cap, making sure it is tight.
11. Close and latch the access assembly and doors.

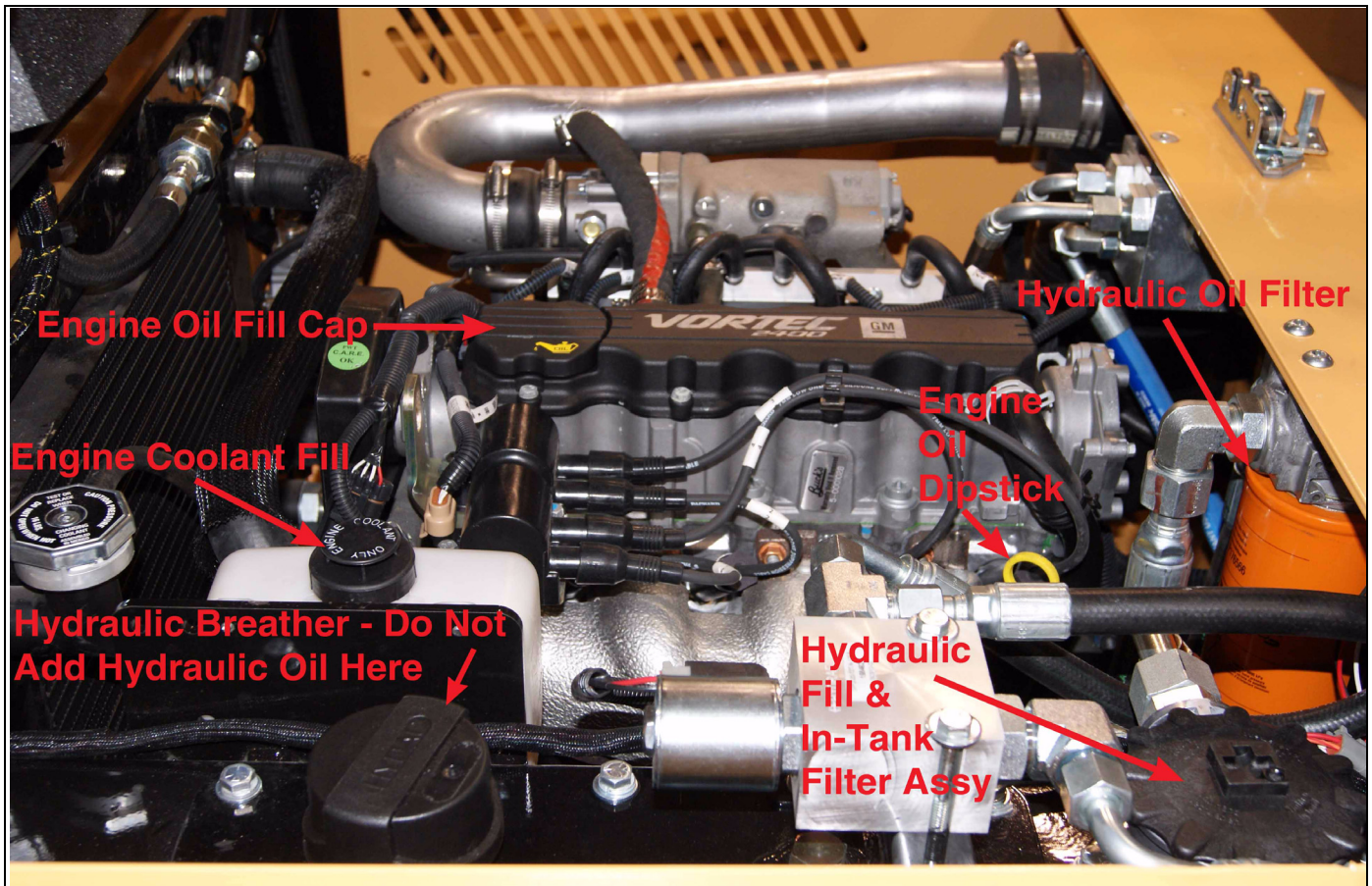

Figure 2-6: Engine Compartment Fluid Checks

Forks and Side Shifter

1. See Figure 2-21.
2. Start the truck and position the mast straight ahead.
3. Set the Keyswitch to OFF and remove the key.
4. Before lubricating the rails, wipe off any excess lubricant and dirt buildup from within the rail channels.
5. Grease the two rail fittings across the top of the carriage rail until fresh grease is seen.
6. Wipe off any excess grease.

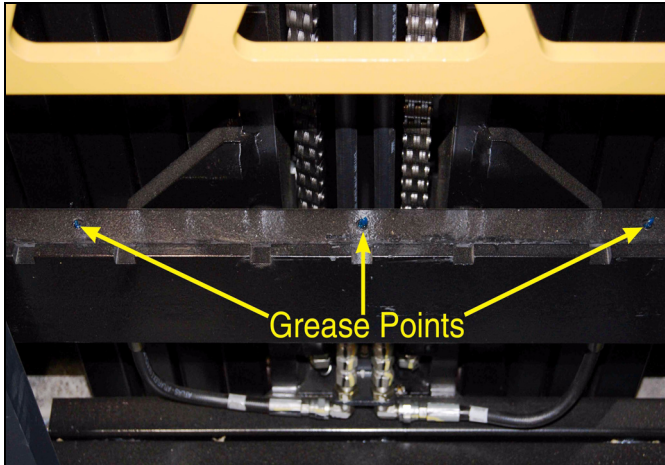

Figure 2-21

Fork Positioner Lubrication, Non-Side Shifting

1. See Figure 2-22.
2. Start the truck and position the mast straight ahead.
3. Set the Keyswitch to OFF and remove the key from the ignition switch.
4. Before lubricating the positioner rails, wipe off excess lubricant and dirt buildup from within the rail channels and dirt from the top and bottom of the rail grooves.
5. Using a brush, lubricate the shaded areas on the fork rails, including a thin film on the front face of both rails. Wipe off excess grease.
6. Check for hose line routing damage and loose fittings.

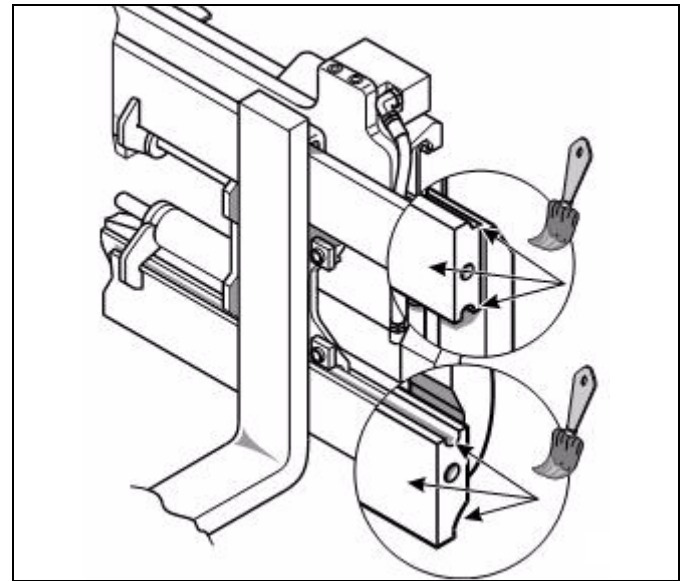

Figure 2-22

Check Radial Piston Hydraulic Motor

These units are internally lubricated by fluid in the hydraulic system. No lubrication or checks are necessary.

Cooling System

Make a visual check of the coolant level.

WARNING
<p>DO NOT remove the radiator cap from the radiator when the engine is hot. When the radiator cap is removed, the pressure is released from the system. If the system is hot, the steam and boiling coolant can cause burns.</p>

1. Make sure the coolant level is between the “ADD COOLANT” and “HOT” marks on the overflow reservoir. The coolant will expand as it is heated and the level in the auxiliary coolant reservoir will increase.
2. If coolant is added, use a 50% mixture of Dexcool and water.
3. Check the radiator fins.
4. Clean the radiator with compressed air/water as needed.

Troubleshooting and Corrective Maintenance

Troubleshooting

This chapter contains troubleshooting procedures to help diagnose and resolve problems.

Once the problem is located you must refer to the Corrective Maintenance Section starting on page 3-14, for repair instructions.

Troubleshooting Chart procedures are arranged as:

1. **Engine Problems**
2. **Hydraulic Problems**
3. **Electrical Problems**
4. **Audible Problems**
5. **Visible Problems**

Problem	Cause	Suggested Repair	
ENGINE PROBLEMS			
Does not start.	No fuel.	<ul style="list-style-type: none"> • Make sure fuel lock off is working. • Check fuel pressure and fuel relay. • Check tank. 	
	No Spark.		<ul style="list-style-type: none"> • Check spark plugs, wires & coil.
No acceleration.	Acceleration pedal out of calibration.	<ul style="list-style-type: none"> • See Throttle Pot Setup on page 4-18 and recalibrate. 	
Runs Rough and/or Sluggish.	Refer to Chapter 5 for engine and fuel system service manuals.		
HYDRAULIC PROBLEMS			
Mast lifts slowly - loss of lift speed.	Attempting to lift a load in excess of the truck's capacity.	<ul style="list-style-type: none"> • NEVER attempt to lift a load heavier than the specified rating of the truck. • Also see "Traveling and Load Handling," in the Bendi B40i3 Operator's Manual F-500 for additional information. • See "Understanding Stability," in the Bendi B40i3 Operator's Manual, F-500. • See "Mast does not lift load," on page 3-4. 	
	Insufficient pump or relief valve pressure.		
	Mechanical damage of the mast.		<ul style="list-style-type: none"> • See "Mast does not lift load," on page 3-4.
	Hydraulic cylinders leaking or binding.		<ul style="list-style-type: none"> • See "Mast does not lift load," on page 3-4.

Problem	Cause	Suggested Repair
VISIBLE PROBLEMS		
<p>Leaking fluid.</p>	<p>Cracked, split, or cut hoses.</p> <p>Loose or faulty hydraulic fittings.</p> <p>Pump or motor oil seals, rings, gaskets, etc. deteriorated by excessive heat or corrosion.</p>	<ul style="list-style-type: none"> • Replace. NEVER attempt to patch a hose. • See “Hydraulic Fittings and Hoses,” on page 3-55. • Tighten and/or replace. Be careful not to strip the threads, rendering the fitting defective. • See “Hydraulic Fittings and Hoses,” on page 3-55. • Replace seals in bad unit or replace unit. • Check appropriate vendor service information, where applicable.
<p>Cracked or exceptionally worn forks.</p> <p style="text-align: center;">DANGER!</p> <ul style="list-style-type: none"> • If you find any defect in the forks or mounting components, take the forklift out of service until the forks are repaired. Failure to do so can cause the load to fall resulting in serious injury or death. <p style="text-align: center;">WARNING!</p> <ul style="list-style-type: none"> •• Forks requiring repair must be returned to the original manufacturer. •• Never try to repair surface cracks or wear by welding. If a fork is reset, make sure it is heat treated before it is returned to service. <ul style="list-style-type: none"> • A fork that has undergone repairs must be load tested before it is returned to service. The test facility must test forks according to paragraph 7.25.3 (ASME B56.1-2000), except that the test load must be 2.5 times the rated capacity marked on the fork. 	<p>Fatigue, age, excessive lifting of overweight loads, straightness of blade and shank, fork angle or height differences between fork tips.</p> <p>Excessive wear or defective hooks.</p>	<ul style="list-style-type: none"> • When replacing forks - Forks must be replaced in pairs. • Check straightness of the upper face of each blade and the front face of each shank. If deviation exceeds 0.5% of the length of the blade and/or height of shank respectively, replace forks. • Check angle between upper face of fork blade and load face of each shank. If deviation exceeds 3° from original specification, replace forks. • Check difference in height between each fork blade (measured at the tip with the fork mounted on the carriage). If difference in tip heights exceeds 3% of the length on the blade, replace the forks. • See “Removing Forks,” on page 3-15. • Check each fork, especially at the heel area. If thickness is reduced to 90% of original thickness, replace the forks. • Check support face of the top hook and the retaining faces of both hooks for wear, crushing or other deformations. Excessive clearance between fork and carriage requires fork replacement.

Front Axle Assembly

To Check Load Wheels

1. First, review "Lifting the Truck," beginning on page 1-5.
2. With the truck raised and supported, spin each wheel and check for noise, rolling resistance and free play.
3. Rock the wheel in and out on the spindle. If there is any noticeable movement, the bearings should be checked and then repacked with grease and/or replaced.



WARNING

- To maintain stability and maximum reliability, you must always replace tires with the type originally supplied, Landoll P/N 109091 (Load Wheels) and P/N 0010998 (Drive Wheels).
- The truck is equipped with tires of a size and hardness that provide the necessary traction and maintain proper shape to prevent tipping.
- It is also recommended to replace worn tires in pairs. Treaded drive tires must be replaced when the tread depth is less than 0.0625" (1.6mm) at the deepest point.

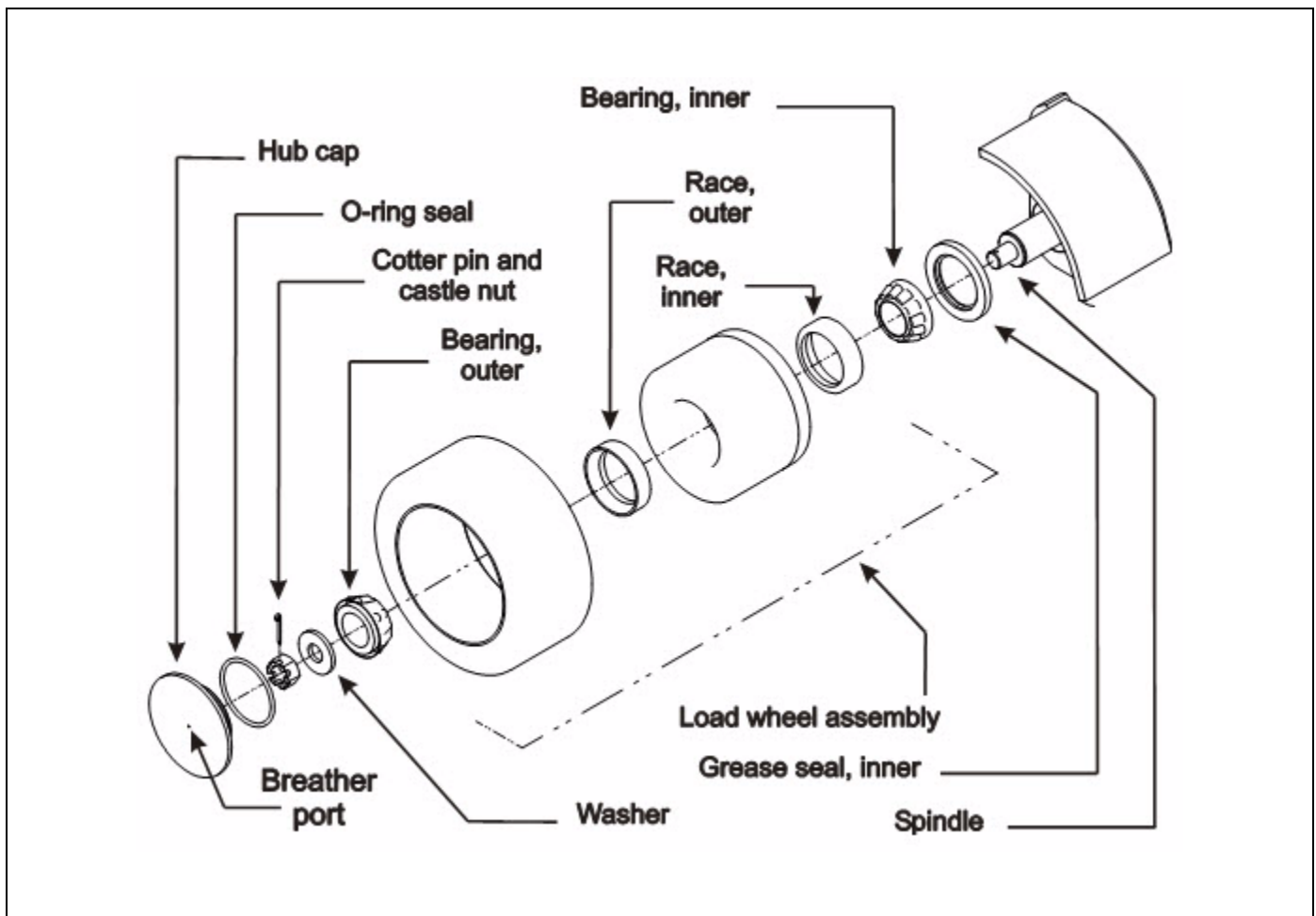

Figure 3-8

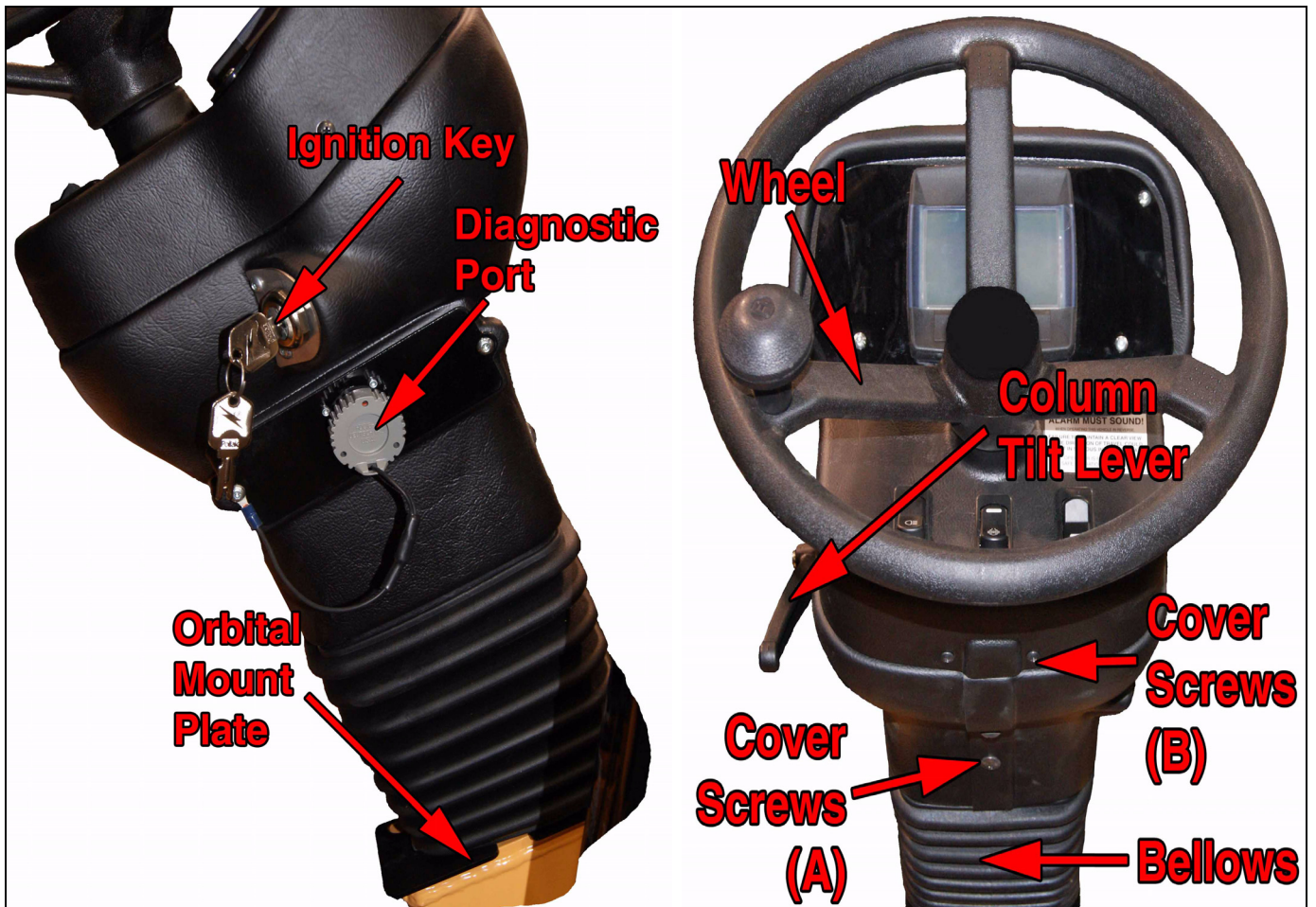

Figure 3-18:

Remove Right Side Cover

1. First, review “Before You Begin,” page 1-1.
2. Set the key switch to OFF and remove the key from the ignition switch.
3. Apply the parking brake and disconnect the battery.
4. Make sure the other wheels are securely blocked so that the truck cannot move.
5. Loosen the Allen set screw in the tilt steering lever and remove the lever from the stem. See Figure 3-18.
6. Remove the four large screws and hardware marked **(A)**. See Figure 3-18.
7. Remove the three right side top cover screws and hardware marked **(B)**. See Figure 3-18.
8. Pry the bellows (rubber boot) free of the steering column cover.
9. Remove the right side cover to expose the internal components of the steering column.

Display

1. Repeat preceding section “Remove Right Side Cover”.
2. Remove the four screws securing the dash panel to the steering console.
3. Reach inside the steering column and disconnect the appropriate display wire connectors from the main wire harness, then lift the panel out.
4. Install the new display by reversing the above steps.
5. Connect the wire connector to the wire harness and close the steering column by reversing the steps outlined in section “Remove Right Side Cover”.

To Remove and Replace Hydrostatic Pump Manifold

1. First, review “Before You Begin (Please Read)” on page 1.
2. Set the key switch to “OFF” and remove key from the switch.
3. Apply the parking brake, disconnect the battery and block the wheels.
4. Remove the 3 floor plate covers. “Floor Plate(s) Removal” on page 3-15.
5. Clean the area around all hose connections and mounting surfaces.
6. Remove all hoses and fittings from the manifold.
7. Remove the 8 mounting bolts.
8. Remove the manifold, ensuring the 2 O-rings are also removed.
9. Clean the mounting surfaces of the hydrostat and the manifold.
10. Install new Landoll P/N 168279 O-rings lubricated with new, clean hydraulic oil.
11. Re-install manifold to the hydrostat and start all 8 bolts.
12. Snug all bolts in a criss cross pattern working from the center out.
13. Torque all bolts to 100ft./lbs (136 N.m) in the same pattern.
14. Re-install all fitting and hoses torqued to the specifications on “Torque Specifications” on page 1-17 to 1-19.

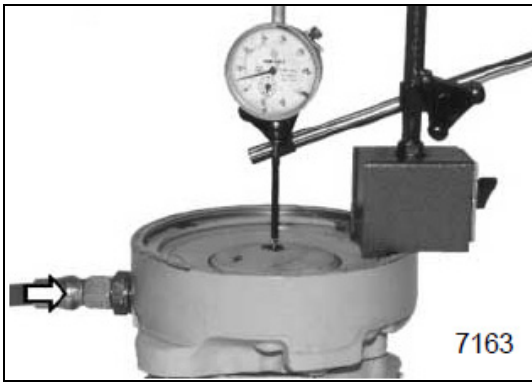

Figure 3-56

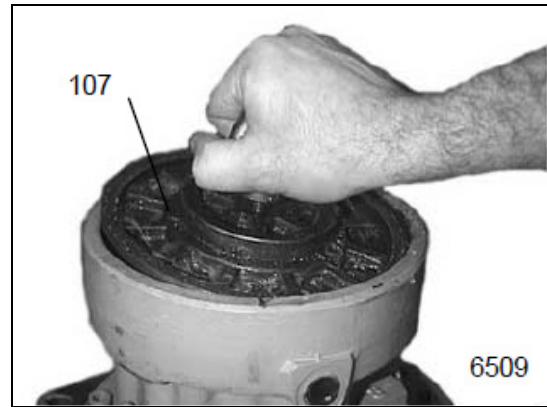

Figure 3-59

26. Calculate the shimming, item 105, value(measured travel) in order to control the stroke of .034" (.87mm). See Figure 3-50.
27. Reapply the compressive force to remove the snap ring, item 109. See Figure 3-57.

30. Install the proper shimming, item 105, on the last disc, **the thickest shim towards the brake piston**. See Figure 3-60.

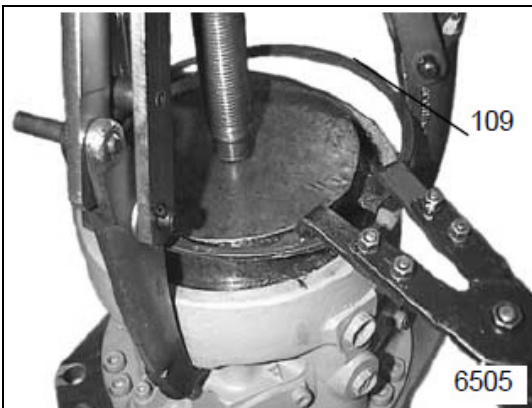

Figure 3-57



Figure 3-60

28. Remove the spring washer. See Figure 3-58.

NOTE

Minimize the number of shims of thickness .0079" (.2mm).



Figure 3-58

31. Reinstall the brake piston, item 107, and the spring washer, item 108. See Figure 3-61.



Figure 3-61

29. Remove the brake piston. See Figure 3-59.

The Plus 1 software package is segregated into two basic operational sections. See Figure 4-7.

- The first section of the software is a monitoring or "Log Function", which allows the user to monitor vital performance settings in the B40i3 forklift.
- The second section, the "Parameter Functions" within the software is where parameters can be manipulated as applicable.
- Follow the screens shots of the Plus 1 provided in the upcoming pages.
- Also shown below you will notice in the right side column the REV control number that may become important as improvements are made in the software, by the factory.

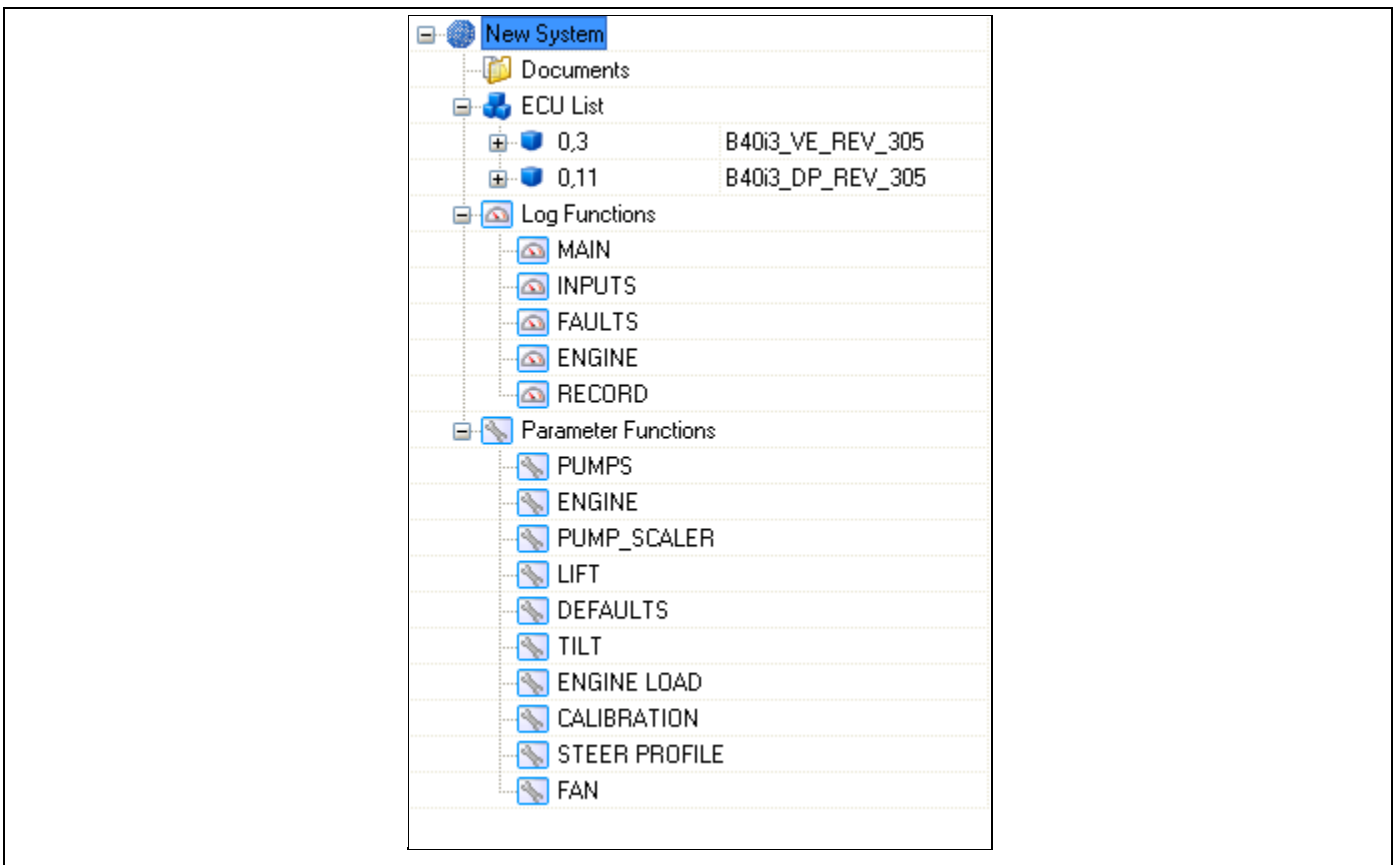

Figure 4-7:

CLICK HERE TO **DOWNLOAD** THE COMPLETE MANUAL

- Thank you very much for reading the preview of the manual.
- You can download the complete manual from: www.heydownloads.com by clicking the link below



- Please note: If there is no response to CLICKING the link, please download this PDF first and then click on it.

CLICK HERE TO **DOWNLOAD** THE COMPLETE MANUAL

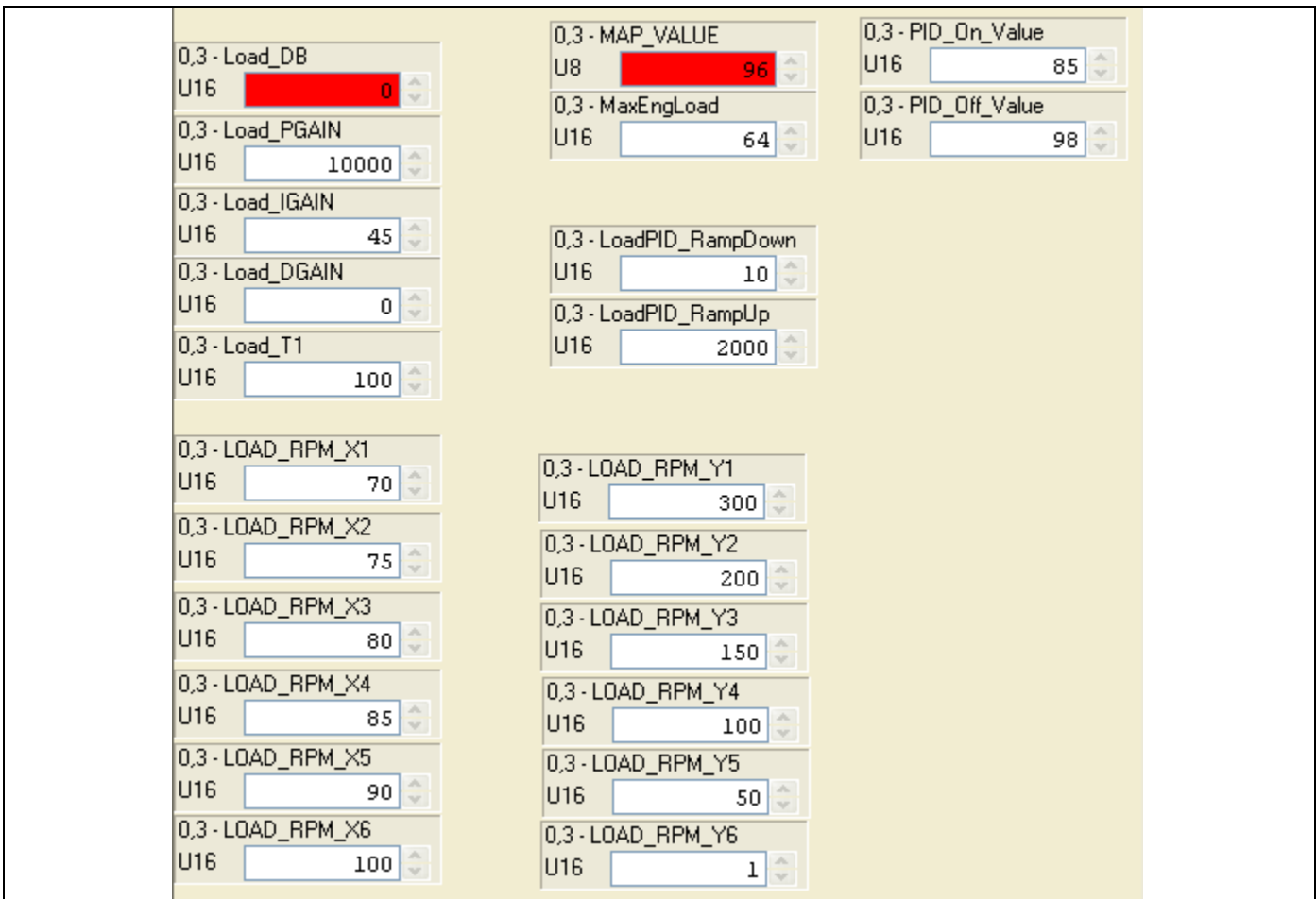

Figure 4-15:

Engine Load Screen

The “ENGINE LOAD” screen shot provides featured parameters for the Plus 1 functions. See Figure 4-15.

Below is provided a definitions list for truck parameters: See Figure 4-15.

0,3-Load_DB – Pre defined in software, for reference only.

0,3-Load_PGAIN – Pre defined in software, for reference only.

0,3-Load_IGAIN – Pre defined in software, for reference only.

0,3-Load_DGAIN – Pre defined in software, for reference only.

0,3-Load_T1 – Pre defined in software, for reference only.

0,3-LOAD_RPM_X1 – Pre defined in software, for reference only.

0,3-LOAD_RPM_X2 – Pre defined in software, for reference only.

0,3-LOAD_RPM_X3 – Pre defined in software, for reference only.

0,3-LOAD_RPM_X4 – Pre defined in software, for reference only.

0,3-LOAD_RPM_X5 – Pre defined in software, for reference only.

0,3-LOAD_RPM_X6 – Pre defined in software, for reference only.

0,3-MAP_VALUE – Pre defined in software, for reference only.

0,3-MaxEngLoad – Pre defined in software, for reference only.

0,3-LoadPID_RampDown – Pre defined in software, for reference only.

0,3-LoadPID_RampUp – Pre defined in software, for reference only.

0,3-LOAD_RPM_Y1 – Pre defined in software, for reference only.

0,3-LOAD_RPM_Y2 – Pre defined in software, for reference only.

0,3-LOAD_RPM_Y3 – Pre defined in software, for reference only.

0,3-LOAD_RPM_Y4 – Pre defined in software, for reference only.

Electronic Throttle

The electronic throttle plate is commanded to open by the ECU. A servo motor on the throttle opens the throttle plate and a throttle position sensor sends a signal back to the ECU to confirm the commanded opening is achieved. The electronic throttle performs the tasks of idle and over-speed governing. If there is a sensor failure in the throttle the power to the motor is shut off and the plate assumes a limp home position (just slightly open to allow a high idle of the truck).

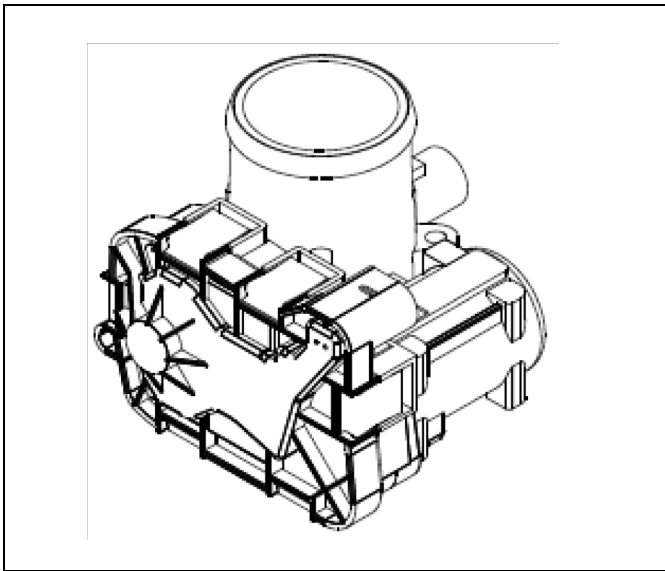

As mentioned previously, if there is a throttle related failure, the electronic throttle will go into a “LIMP HOME” mode of operation. This mode of operation has the symptom of no engine response to the pedal. Check for any throttle body codes and remedy the situation. Then clear the codes and key off the vehicle and let sit for at least 30 seconds. This resets the ECU and removes the “LIMP HOME” throttle mode and should return pedal response. The “LIMP HOME” mode can be triggered by simply disconnecting the throttle body connector while the vehicle power is on. If the throttle body of an engine has to be replaced, the range of travel of the new throttle has to be learned by the ECU. It is important to open the S3000 monitor software, see page 5-17 through page 5-20, to clear the EEPROM in the diagnostics tab. The Keyswitch must then be turned off for 30 seconds. When the key is switched back on the ECU will cycle the throttle body through the full range of motion to re-learn the throttle body end stops.

S3000 Engine Control Unit (S3000)

The S3000 ECU is the command and control unit for the 2.4 liter LPG engine. The ECU monitors inputs, performs engine management calculations and controls outputs to achieve the desired engine performance. The ECU also monitors the various input and output components, as well as it's own internal functioning, for failures and then alerts the operation if any failures occur. The ECU also supplies the truck controller with various engine operating parameters to allow for proper truck operation. The S3000 ECU along with the S3000 Monitor software allows monitoring and recording of engine operating parameters as well as reading and clearing engine Diagnostic Trouble Codes (DTCs). The S3000 Monitor software is run in a Windows XP operating system on a laptop or desktop PC. The connection from the PC to the S3000 is through a Kvaser or iFak cable which connects to the USB port of the PC and to the CAN BUSS lines of the S3000 ECU (pin 2 of the 9 pin connector is CAN L and pin 7 is CAN H). The corresponding CAN wires can be found on the engine harness 8 pin Duetch connector CRP83 pins 7 (CAN H)and 8 (CAN L). See Figure 4-2.



The ECU (S3000) opens the throttle to the required opening to obtain the commanded speed. It then calculates the airflow into the engine based on MAP, speed, air and coolant temperature. The correct amount of fuel for the this airflow is calculated and injection signals, compensated for the actual measured fuel pressure, are sent to the injector driver unit which drives the peak and hold current injectors to deliver fuel to each intake manifold runner in sequence. The spark timing is set for optimum drivability and emissions. The resulting fuel air mixture is burned in the cylinder supplying torque to the crankshaft. The heated exhaust gas oxygen (HEGO) sensor is used to determine if the fueling was rich or lean of mixture and the injector pulse widths are then trimmed to provide fueling, which cycles the air to fuel ratio around the optimum 15.7 : 1 air to fuel ratio, to achieve maximum catalyst reduction of pollutants.

Are the injectors firing?

The best and most thorough way to check the injector circuit is to insert a “noid” light in place of the injectors one by one and cranking the engine to see that the light flashes. A noid light can be approximated by using a 12 volt flashlight or tail-light bulb with wires soldered to the positive and negative contacts of the bulb. To see if the injectors are mechanically stuck, replacement with known good injectors is the best test. To find if there is one bad injector in the bunch take the engine rpm up to approximately 1200 rpm and using the S3000 monitor’s “Injector” tab disable one injector at a time and see if there is a drop in rpm, as each injector in turn is disabled (the rpm needs to be above idle since if the truck is on idle the idle governor will try to keep the rpm constant by opening the throttle when you disconnect an injector). If disabling an injector has no effect on the rpm it is likely that cylinder is not firing.

Is there fuel pressure at fuel rail?

Fuel pressure can be read via the S3000 monitor. The fuel pressure should be approximately 180 to 210 kPa when the engine is not running and 88 kPa above manifold pressure when it is running (this is approximately 125 to 140 kPa at idle). If the engine will start and run look at the “Feedback” window on the S3000 Monitor, if the values are hitting -25% or +25% this may indicate the fuel pressure is too high or too low. Check that the vacuum line that supplies the manifold pressure, from the manifold to the vaporizer, is connected and not leaking or plugged.

Is LPG vaporizer Lock-Off opening or is the gasoline fuel pump coming on?

You should be able to hear the gasoline fuel pump come on for two seconds, after the key is on [after a 20 second key off]. The LPG lock-off can be checked for activation with a iron bar (or other metal which is attracted to a magnet), by holding it close but not touching the solenoid tower of the vaporizer and then turning the key on. Since the vaporizer solenoid is a high side control it can also be checked by watching for the appearance of battery voltage at CPS207 pin 1 at key on (for 2 seconds as mentioned above).

Do you have No or Low Cylinder compression?

Check compression in each cylinder using a compression gauge. Typically a cylinder will have 140 to 160 PSI of cranking compression. Low compression could be caused by burnt exhaust valves, a bad head gasket, worn rings and cylinder or a broken timing belt.

DTC codes

Shown on the next page are the DTC codes with descriptive details:

CRANKSHAFT TIMING PULLEY**Removal****↔ Remove or disconnect**

1. V pulley belt; see "*V Pulley Belt - Removal*", in this section.
2. Timing pulley attaching bolt, with a 13-mm socket wrench and handle, and tool 3-0006772 to hold the pulley; ①
3. Timing pulley; if it is locked, use tool 6-8604028 to remove the same ②
4. Timing pulley key

Installation**↔ Install or connect**

1. Key in the timing pulley
2. Timing pulley and attaching bolt, without tightening
3. Use tool 3-0006772 to hold the pulley and with a 13-mm socket wrench, tighten

**Tighten**

- Bolt: 135 + 30° + 15° (99 lb.ft. + 30° + 15°)
4. V pulley belt; see "*V Pulley Belt - Installation*", in this section.

CRANKSHAFT FRONT SEAL**Removal****↔ Remove or disconnect**

1. Timing belt; see "*Timing Belt - Removal*", in this section
2. Crankshaft timing pulley; see "*Crankshaft Timing Pulley - Removal*", in this section
3. Crankshaft seal. For this operation, drill a hole in the seal front face and install a fine threaded bolt (arrow). With the aid of pliers, remove the seal. ③

①

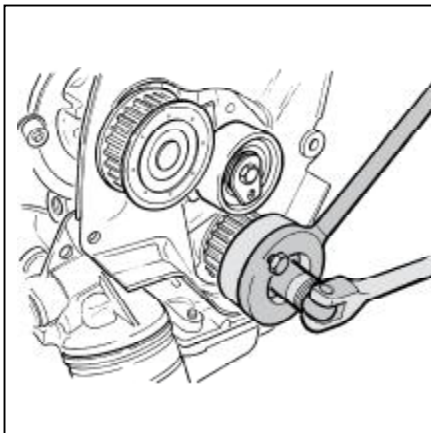

②

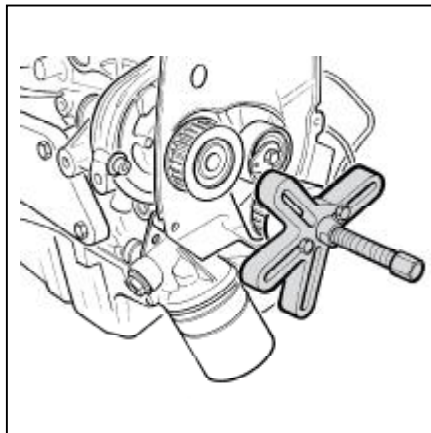

③

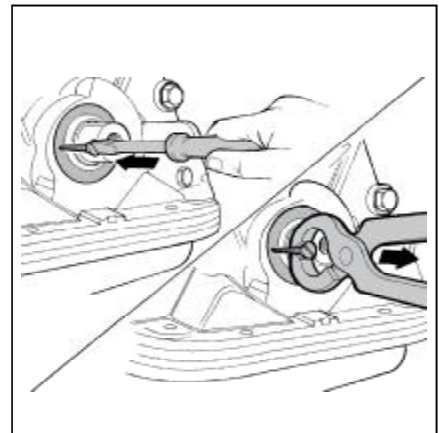

40. Lock; for that, displace the camshaft a little to the outside
41. Camshaft, by its rear side

Installation

↔ Install or connect

1. Camshaft in the case



Important

- Despite the camshaft end being chamfered, take care not to damage the seal
- When installing a new camshaft, drain the engine oil, apply zinc dithiophosphate additive in the camshaft lobes and rocker arms and add the remaining additive to the new engine oil.

2. Camshaft lock and attaching bolt, without tightening ①
3. With a 5-mm Allen wrench and torque wrench, give the final tightening



Tighten

- Bolts: 4 – 10 N.m
4. Camshaft case rear cover, with a new gasket and attaching bolts, without tightening
 5. With a 10-mm socket wrench and torque wrench, give the final tightening



Tighten

- Bolts: 6 – 10 N.m
6. New cylinder head gasket to the cylinder block ②

7. Cylinder head together with the exhaust and intake manifolds, positioning them in the cylinder block
8. Valve lifters, pad and rocker arms (3) ③
9. Camshaft case with the camshaft assembled
10. Camshaft and cylinder head new attaching bolts, without tightening

①

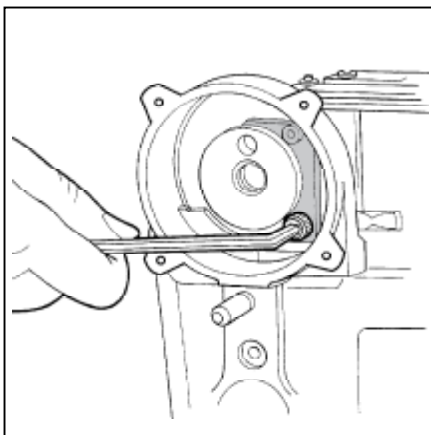

②

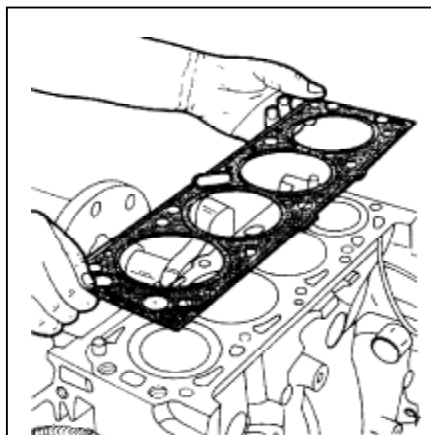

③

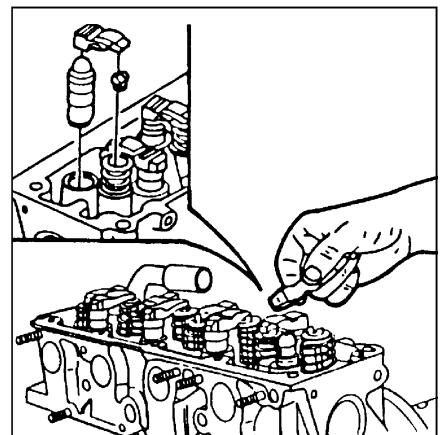

47. With a 10-mm combination wrench, tighten



Tighten

- Bolts: 10 – 12 N.m (7 – 8,8 lb.ft)

48. DIS coil electric connection
 49. Spark plug cables
 50. Radiator; see “Radiator – Installation”, section 6B
 51. Engine hood; see “Engine Hood – Installation”, section 10-5
 52. Refill the power steering pump oil reservoir

ENGINE DISASSEMBLY

Removal



Remove or disconnect

1. Engine assembly, as per instructions under “Engine Assembly – Removal”, in this Section
2. Generator attaching bolt, with a 13-mm wrench; remove the generator
3. Power steering pump attaching bolts, with a 13-mm wrench; remove the pump
4. Exhaust manifold nuts, with a 13-mm socket wrench, extension and handle; remove the exhaust manifold
5. Intake manifold nuts, with a 13-mm socket wrench, extension and handle; remove the intake manifold
6. Crankcase vent tube attaching bolt, with a 13-mm socket wrench, extension and handle; remove the crankcase vent tube
7. Align the camshaft timing pulley mark with the timing belt rear cover mark
8. Align the crankshaft timing pulley mark with the oil pump case flange mark
9. Timing pulley front cover attaching bolts, with a 10-mm socket wrench, extension and handle; remove the front cover
10. Timing belt tensioner bolt, to relieve the tension of the belt, with a 13-mm combination wrench; remove the timing belt
Obs.: Turn the crankshaft 45° clockwise, so as to prevent damaging the engine and cylinder head inner components.
11. Camshaft cover attaching bolts, with a 10-mm socket and handle; remove the camshaft cover
12. Camshaft pulley attaching bolt, using a 17-mm combination wrench and a 22-mm wrench to attach the camshaft; remove the camshaft pulley ①
13. Install tool S-9407182 and attach the engine flywheel; with a 19-mm combination wrench, attach the tool bolt ②
14. Crankshaft timing pulley attaching bolt, with a 17-mm socket wrench and handle; remove the bolt

①

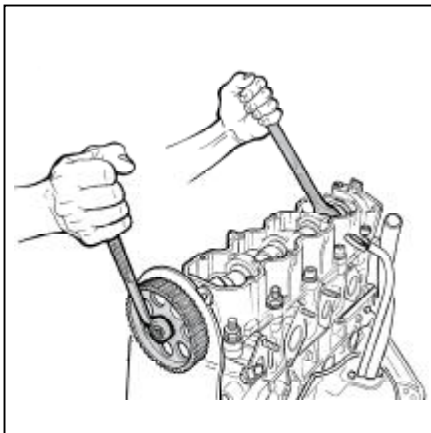

②

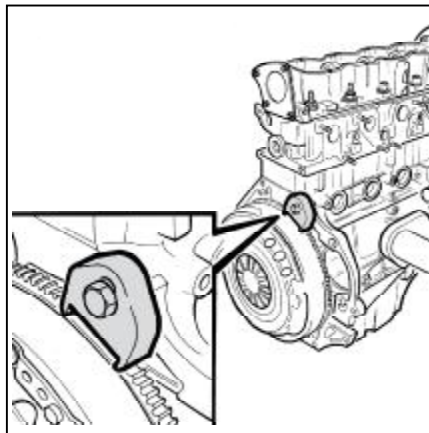

③

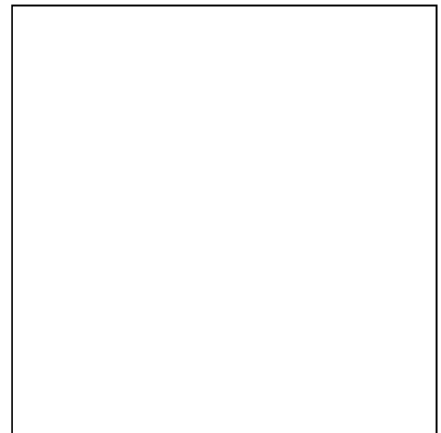

Installation**↔ Install or connect**

1. Upper shells in the block; lubricate the surface turned toward the saddle with engine oil.
2. Crankshaft
3. Main bearing caps with the shells lubricated on the surfaces turned toward the saddle

! Important

- The bearing caps should be installed so that the cast numbers base (1) stays turned toward the engine rear side. Pay attention also to the sequential engraved numbers. ①
 - Fill the rear bearing cap side grooves with sealant.
4. Main bearing attaching bolts, without tightening

! Important

- With a plastic mallet, slightly tap the crankshaft, in two directions, so as to mainly seat the thrust bearing rear face. ②

5. Tighten the main bearing attaching bolts, with a Torx E12 wrench, extension and torque wrench.

🔧 Tighten

- Bolts: 60 N.m (45 lb.ft.) + 40° to 50°

📏 Measure

Crankshaft end clearance, as follows:

- Install a dial gauge so that the probe touches the crankshaft end ③
 - With the aid of a screwdriver, displace the crankshaft to and fro and read the dial gauge
 - The specified clearance is 0.070 – 0.302 mm (0.003 – 0.012 in.).
6. A new seal in the crankshaft, with tool 3-0006775. ④
 7. Piston-connecting rod assembly with the aid of the universal band, positioning the piston arrow turned toward the engine front end ⑤

①

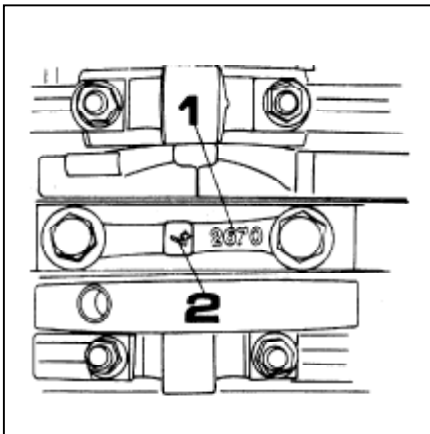

②

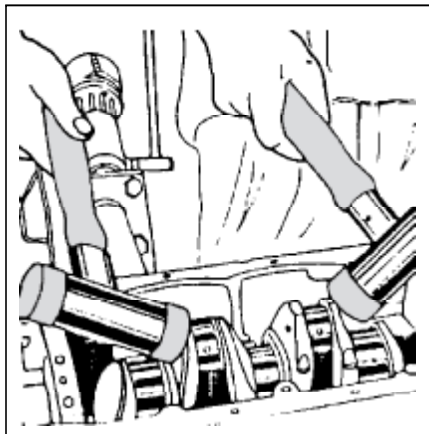

③

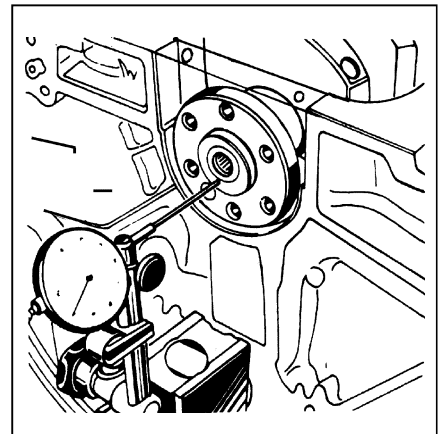

④

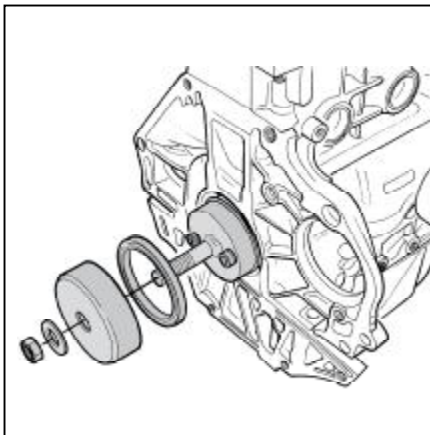

⑤

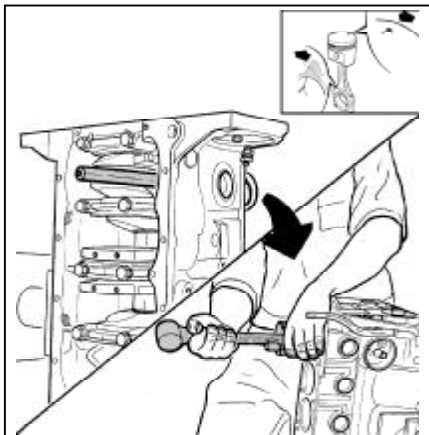

⑥

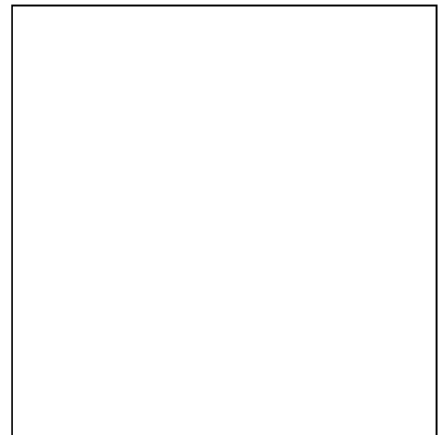

**SHELLS SELECTION TABLE
MAIN BEARINGS – STANDARD SIZE (*)**

BLOCK	0		62.0000	62.0065	0		62.0065	62.0130
CRANKSHAFT	BROWN	57.9885	GREEN	57.9820	BROWN	57.9885	GREEN	57.9820
		57.9950		57.9885		57.9950		57.9885
UPPER SHELL	BROWN	1.989	BROWN	1.989	GREEN	1.995	GREEN	1.995
		1.995		1.995		2.001		2.001
LOWER SHELL	BROWN	1.989	GREEN	1.995	BROWN	1.989	GREEN	1.995
		1.995		2.001		1.995		2.001
CLEARANCE	0.015 – 0.040		0.0155 – 0.0405		0.0155 – 0.0405		0.016 – 0.041	

MAIN BEARINGS – 0.25 OVERSIZE (*)

BLOCK	0		62.0000	62.0065	1		62.0065	62.0130
CRANKSHAFT	BROWN/ BLUE	57.7385	GREEN/ BLUE	57.7320	BROWN/ BLUE	57.7385	GREEN/ BLUE	57.7320
		57.7450		57.7385		57.7450		57.7385
UPPER SHELL	BROWN/ BLUE	2.114	BROWN/ BLUE	2.114	GREEN/ BLUE	2.120	GREEN/ BLUE	2.120
		2.120		2.120		2.126		2.126
LOWER SHELL	BROWN/ BLUE	2.114	GREEN/ BLUE	2.120	BROWN/ BLUE	2.114	GREEN/ BLUE	2.120
		2.120		2.126		2.120		2.126
CLEARANCE	0.015 – 0.040		0.0155 – 0.0405		0.0155 – 0.0405		0.016 – 0.041	

(*) ALL MEASURES ARE IN MILLIMETERS

Section 2 Installation Instructions

2.4 Inspection and Adjustments

2.4-1 Chain Inspection and Tension

The hoist Chains have been factory lubricated using heat and pressure to force the lubricant thoroughly into the chain links. Avoid removal or contamination of this factory applied lubricant. **Do not wash, sand blast, etch, steam clean, or paint the chains for internal mast installation.**

The chains must be adjusted with equal tension to ensure proper load distribution and mast operation. To determine equal tension, extend the unload mast to put the chains under tension. Press the center of a strand of chain with your thumb, then press at the same place on the other chain of the pair. Each chain in a pair should have equal "give". If they do not have equal tension, perform the hoist chain adjustments described in Section 5.6-3 and 5.6-4.

2.4-2 Main Lift Chain Adjustment

SEE SECTION 5.6-4.

2.4-3 Free Lift Chain adjustment

SEE SECTION 5.6-6.

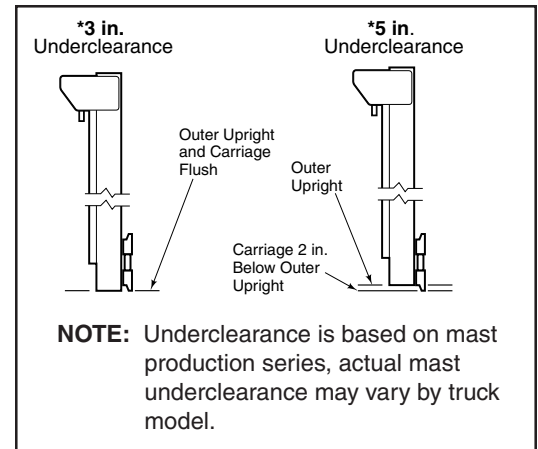

Figure 5. Upright and Carriage Position.

Section 4 Troubleshooting

The following table lists problems that may be encountered on your Lift Tek Mast, the probable causes and recommended corrective action that should be taken to restore the mast to normal operating condition.

PROBLEM	PROBABLE CAUSE	SOLUTION
Cylinders don't lift load or won't move Empty	a) Plugged inlet hose	a) Unplug hose or replace.
	b) Insufficient oil.	b) Check the truck hydraulic system for correct oil level in tank, defective pump or pump drive, leaks in the lines or disconnect control valve linkage. Repair or replace as necessary.
	c) Bent or jammed plunger.	c) Repair or replace as necessary.
Loaded	⚠ WARNING: Extreme care should be used when working on a unit when the carriage (with or without a load) is in the raised position.	
	a) Plugged piston check valve.	a) Unplug check valve or replace.
	b) Truck relief valve setting low.	b) Raise truck relief setting to specified level.
	c) Over capacity.	c) Reduce load to specified capacity.
	d) Mechanical bind due to bent plunger or bad rollers.	d) Remove mechanical bind by replacing/freeing plunger and rollers.
⚠ WARNING: Extreme care should be used when working on a unit when the carriage (with or without a load) is in the raised position.		
Cylinders drift-	a) External leak in pressure line.	a) Tighten or replace as necessary.
	b) Truck valve defective-cycle to full lift height to verify.	b) Repair or replace truck valve.
	c) External leaks at retainer.	c) Replace all cylinder seals.
	d) Piston check valve leaking.	d) Replace check valve.
Spongy or jerky action-	a) Sticky or defective truck relief valve.	a) remove and check the truck relief valve. If contaminated oil caused the malfunction, drain and flush the system, change the filter and refill with fresh oil.
	⚠ WARNING: Extreme care should be used when working on a unit when the carriage (with or without a load) is in the raised position.	
	b) Bent or damaged cylinder plunger.	b) Disassemble, check and repair cylinder assembly.
	⚠ WARNING: Extreme care should be used when working on a unit when the carriage (with or without a load) is in the raised position.	
	c) Load rollers not properly adjusted or defective.	c) Adjust or repair as necessary.
	⚠ WARNING: Extreme care should be used when working on a unit when the carriage (with or without a load) is in the raised position.	
	d) Mast channels improperly lubricated.	d) Lubricate mast.
	⚠ WARNING: Extreme care should be used when working on a unit when the carriage (with or without a load) is in the raised position.	
	e) Low Battery charge.	e) Charge battery.
	f) Low pump volume.	f) Install accumulator.
g) Low oil level.	g) Fill oil reservoir.	
h) Insufficient hydraulic tank capacity or baffles.	h) Install larger tank baffles	

Section 5 Service

5.2-8 Main Lift Cylinder Service

1. Remove the cylinder from the mast as described in Section 5.2-5.
2. Use a claw type spanner wrench to remove the retainer. See Figure 27.
3. **Remove** the plunger/piston assembly from the shell.
4. Remove the Hydraulic Fuse/Lowering Cushion components.
5. Inspect all components for nicks or burrs. Minor nicks or burrs can be removed with 400 grit emery cloth. **NOTE:** Minor nicks are those that will not bypass oil when under pressure. If they cannot be removed with emery cloth, replace the part. If the piston requires replacing, refer to Section 5.2-10.
6. Replace the retainer and piston seals, back-up rings O-rings and bearing. Lubricate the new seals with petroleum jelly prior to installation. **Note the correct seal directions.** The cylinder will not operate correctly if the seals are installed backwards.
7. **2000 PSI CYLINDERS-** When replacing the piston check valve O-ring, make sure the check valve is reinstalled with the arrow pointed in the correct direction.
8. Install the plunger retainer on the plunger. Install the plunger/piston assembly into the cylinder shell. Tighten the retainer to the torque value listed below using the claw spanner wrench and a strap wrench.

30D/35D/40D- 95-125 ft.-lbs. (129-169 Nm)
50D/55D/60D- 225-250 ft.-lbs. (305-340 Nm)

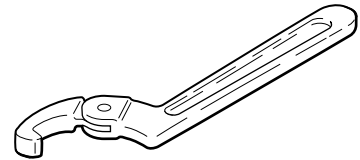
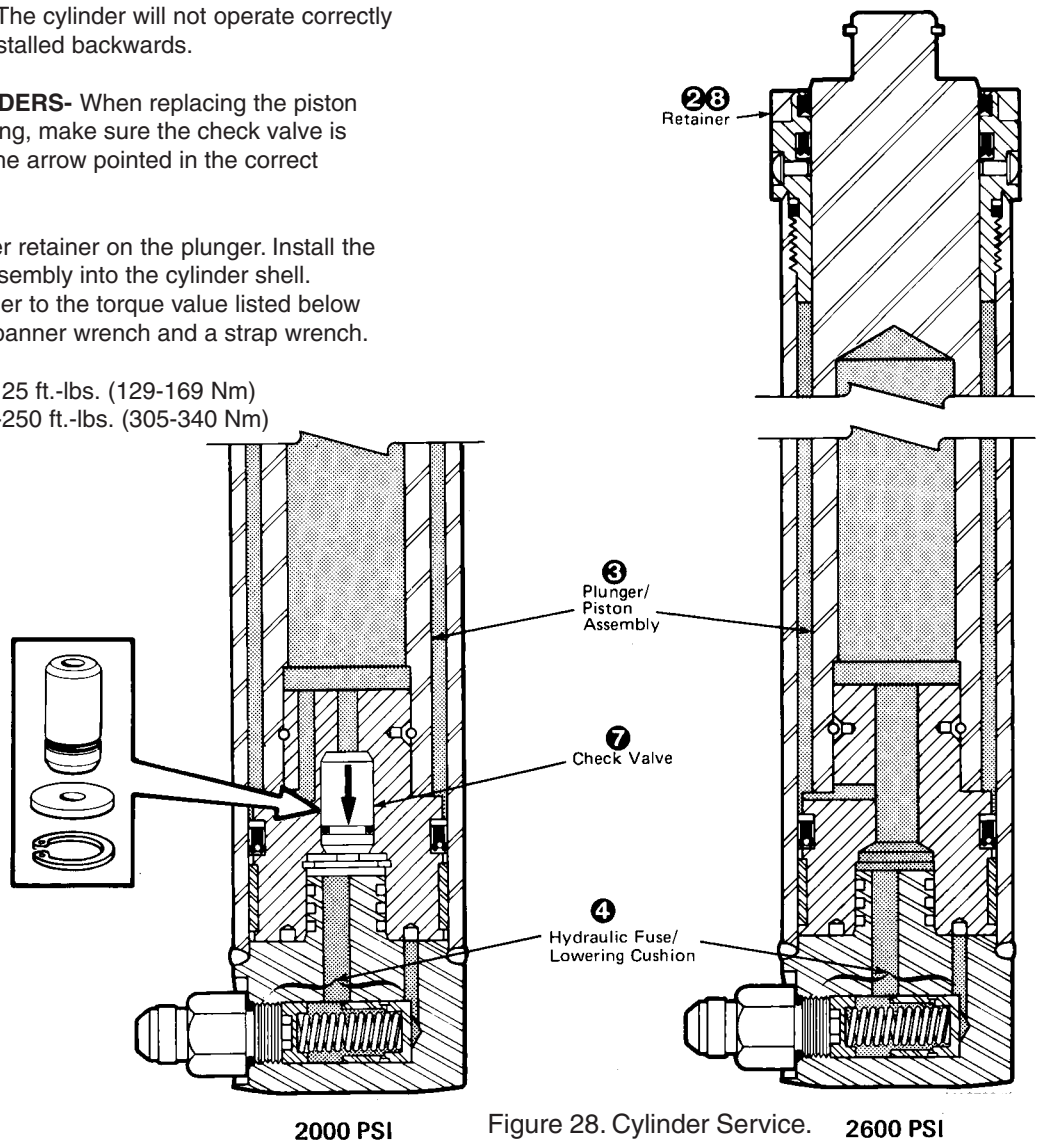

Figure 27. Claw Type Spanner Wrench..



2000 PSI

Figure 28. Cylinder Service. 2600 PSI

Section 5 Service

5.5-3 Upright Disassembly

(Continued)

CAUTION: The chain anchor nuts should be used one time only and be replaced after removal.

13. Remove the main lift chain anchors (long anchors) and chains from the outer upright crossmember. Tag the anchors for reassembly.
14. Roll the inner upright downward to expose the intermediate and outer upright load rollers. Remove the load rollers. Note the number of shims behind each load roller.
15. Attach an overhead hoist to the intermediate upright. Remove the intermediate upright through the top of the outer upright.

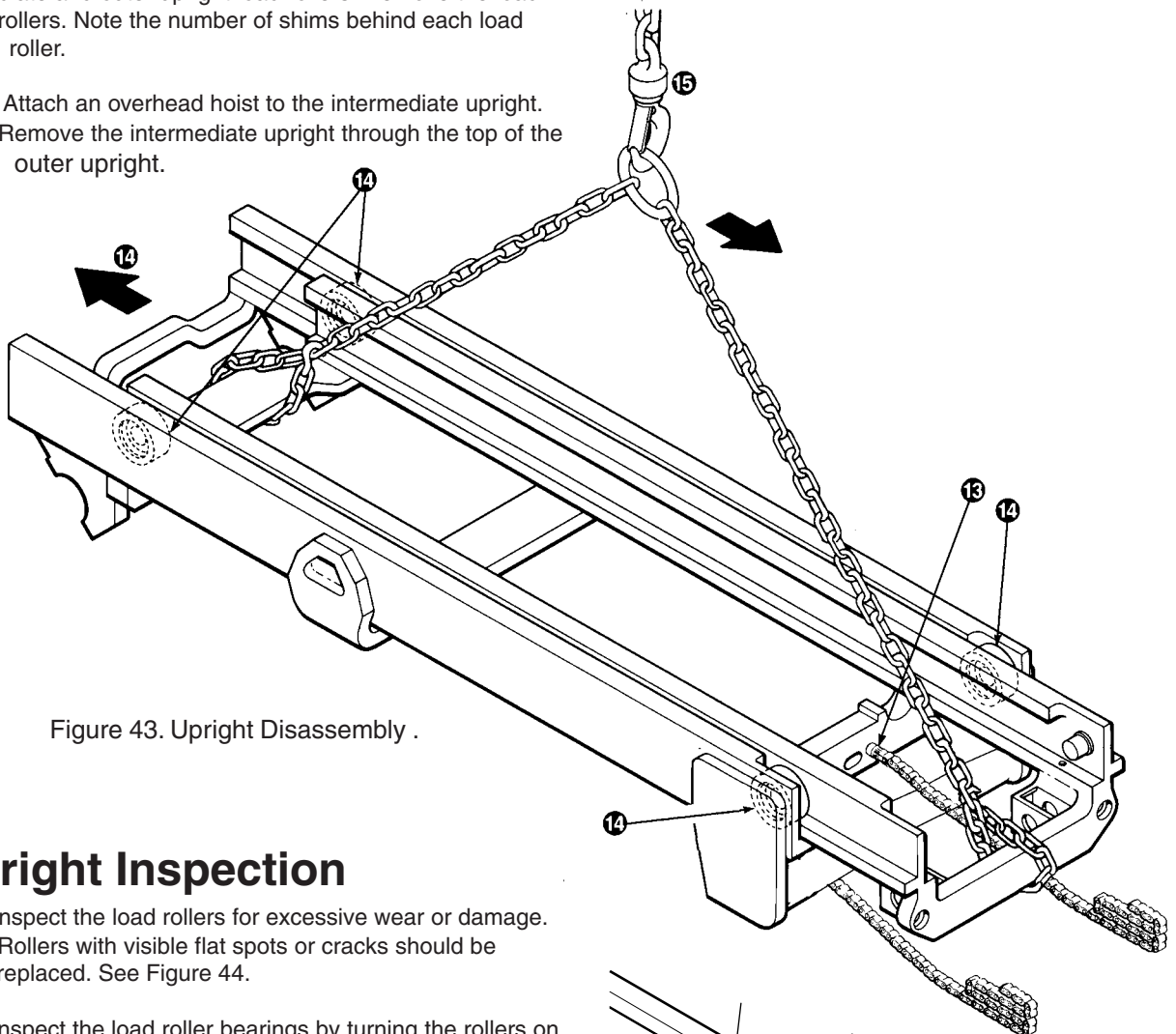

Figure 43. Upright Disassembly .

5.5-4 Upright Inspection

1. Inspect the load rollers for excessive wear or damage. Rollers with visible flat spots or cracks should be replaced. See Figure 44.
2. Inspect the load roller bearings by turning the rollers on their shafts. Rollers with roughness or noticeable restrictions to turning should be replaced.
3. Inspect the load roller stub shafts. If they are damaged or have cracks at the base, the upright mast must be replaced or repaired.
4. Inspect the outer and intermediate upright thrust plugs. If the wear surface is worn to less than 1/16 in. (1.5 mm), they should be replaced.
5. Inspect the hoist chains as described in Section 5.6-1.

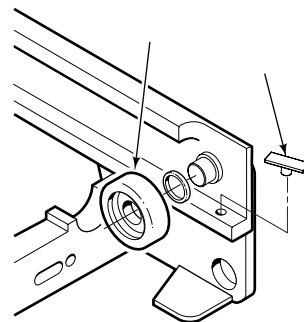

Figure 44. Upright Inspection .

CLICK HERE TO **DOWNLOAD** THE COMPLETE MANUAL

- Thank you very much for reading the preview of the manual.
- You can download the complete manual from: www.heydownloads.com by clicking the link below



- Please note: If there is no response to CLICKING the link, please download this PDF first and then click on it.

CLICK HERE TO **DOWNLOAD** THE COMPLETE MANUAL