

Operating Instructions

Hydraulic Excavator

6060 AC No.

Bucyrus HEX GmbH



CLICK HERE TO **DOWNLOAD** THE COMPLETE MANUAL

- Thank you very much for reading the preview of the manual.
- You can download the complete manual from: www.heydownloads.com by clicking the link below



- Please note: If there is no response to CLICKING the link, please download this PDF first and then click on it.

CLICK HERE TO **DOWNLOAD** THE COMPLETE MANUAL

1 INTRODUCTION

	Operating instructions	Target group
Part 1	INTRODUCTION FUNDAMENTAL SAFETY INSTRUCTIONS	Operating personnel + Inspection and servicing personnel + Repair personnel
Part 2	OPERATION	Operating personnel The operating personnel must have know-how relevant to the operation and the application of this or comparable machines.
Part 3	INSPECTION AND SERVICING	Inspection and servicing personnel The inspection and servicing personnel must have know-how relevant to the inspection and servicing of this or comparable machines.
Part 4	REPAIR WORK	Repair personnel The repair personnel must have know-how and experience relevant to the repair of this or comparable machines.
Part 5	ANNEX	Operating personnel + Inspection and servicing personnel + Repair personnel
Part 6	INDEX	Operating personnel + Inspection and servicing personnel + Repair personnel

Gas, dust, steam and smoke

Always start and operate the engine in a well-ventilated area;

If in an enclosed area, vent the exhaust to the outside;

Do not modify or tamper with the exhaust system

Diesel engine exhaust and some of its constituents are known to cause cancer, birth defects, and other reproductive harm

Operate fuel-operated heating systems only on adequately ventilated premises. Before starting the machine on enclosed premises, make sure that there is sufficient ventilation.

Observe the regulations in force at the respective site.

Carry out welding, flame-cutting and grinding work on the machine only if this has been expressly authorized, as there may be a risk of explosion and fire.

Before carrying out welding, flame-cutting and grinding operations, clean the machine and its surroundings from dust and other inflammable substances and make sure that the premises are adequately ventilated (risk of explosion).

Hydraulic / pneumatic equipment

Check all lines, hoses and screwed connections regularly for leaks and obvious damage. Repair damage immediately. Splashed oil may cause injury and fire.

Depressurize all system sections and pressure pipes (hydraulic / pneumatic system) to be removed in accordance with the specific instructions for the unit concerned before carrying out any repair work.

Hydraulic- and pneumatic lines must be laid and fitted properly. Ensure that no connections are interchanged. The fittings, lengths and quality of the hoses must comply with the technical requirements.

Noise

During operation, all sound baffles of the machine must be closed.

Always wear the prescribed ear protectors.

Oil, grease and other chemical substances

When handling oil, grease or other chemical substances, observe the product-related safety regulations (see safety specifications).

Be careful when handling hot consumables (risk of burning or scalding).

Transporting and recommissioning

The machine must be loaded and transported only in accordance with the operating instructions.

Use only appropriate means of transport and lifting gear of adequate capacity.

The recommissioning procedure must be strictly in accordance with the operating instructions.

FIRE AND EXPLOSION HAZARD

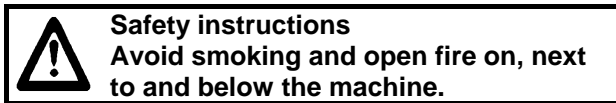

Combustible and easily flammable substances or liquids increase the fire and explosion hazard.

Do not store such substances on the excavator.

Clean the excavator thoroughly, if possible, with a steam jet (rubber parts and electric components with compressed air - refer to information label), when, for example, oil, grease, fuel or cleaner was spilled.

Such substances may spontaneously ignite if they get into the vicinity of hot units.

Even battery gases can ignite in open flames or fire.

Avoid parking the excavator in places where

- combustible substances such as coal dust or tar are present,
- open or smouldering fire may occur.

Remove the excavator from such an area where combustible or easily flammable liquids have spilled from the excavator onto the ground.

Flying sparks may cause fire on the ground that can spread to the excavator.

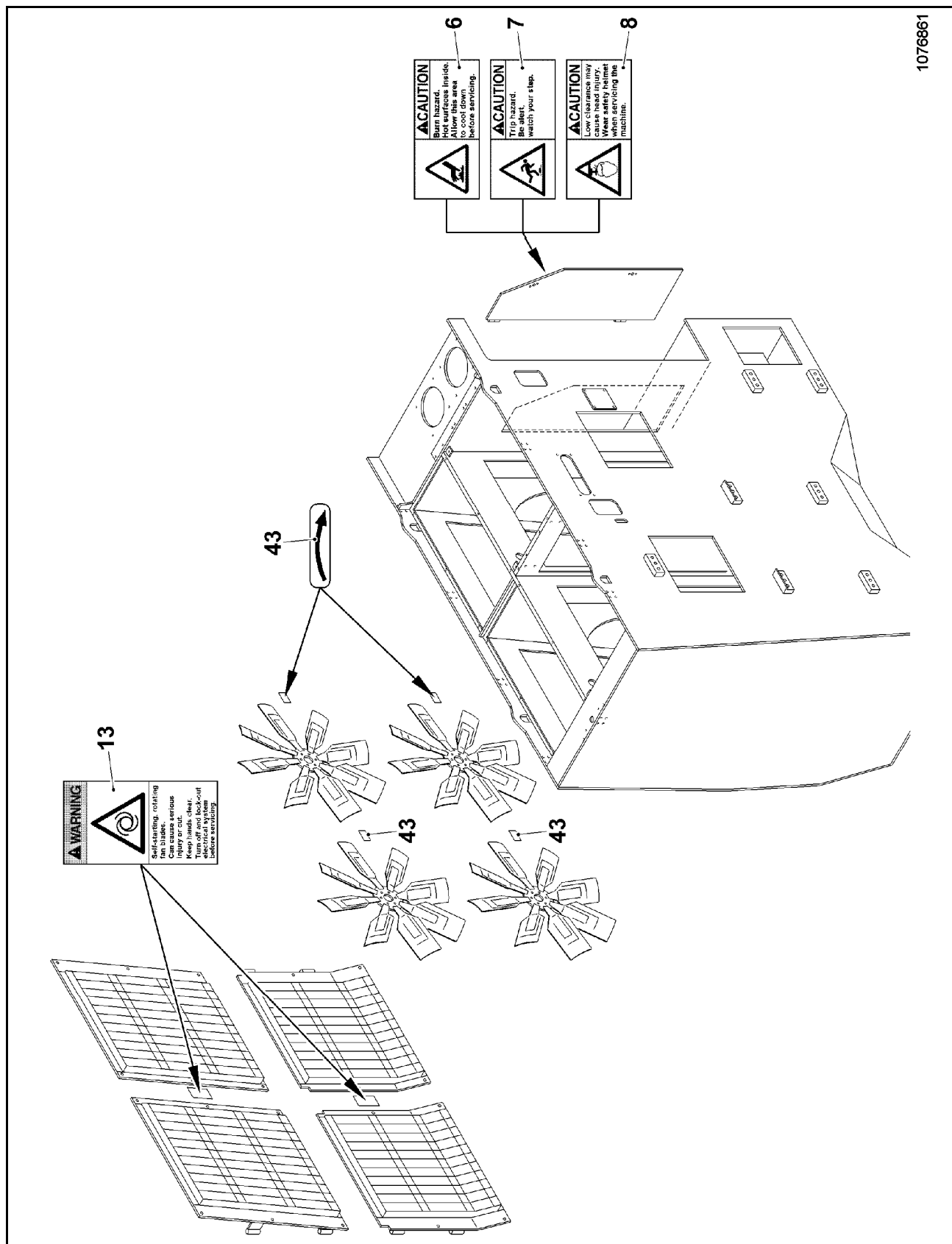

Fig. 2-9:

Cab interior lamp

The interior lamp is switched on and off with switch (Fig. 2-30:).

Switch position 0 - lamp off,
1 - lamp on.

The interior lamp can be used even if the electrical system is switched off.

Therefore, switch off the interior lamp when leaving the machine. The batteries may be discharged if the interior lamp is left on for prolonged periods.

The interior lamp is also switched on and off with switches (arrow, Fig. 2-31:) and / or (96, Fig. 2-32:).

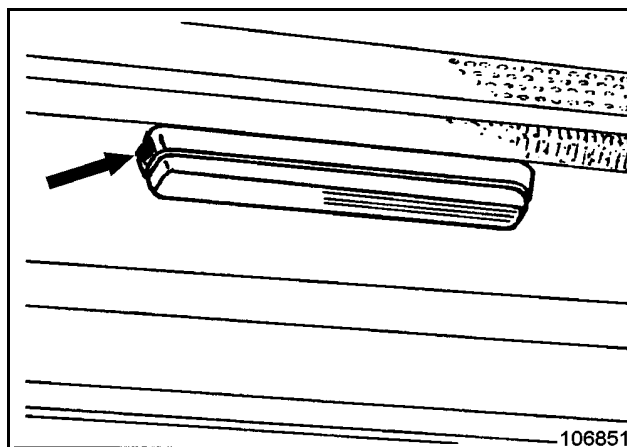

Fig. 2-30:

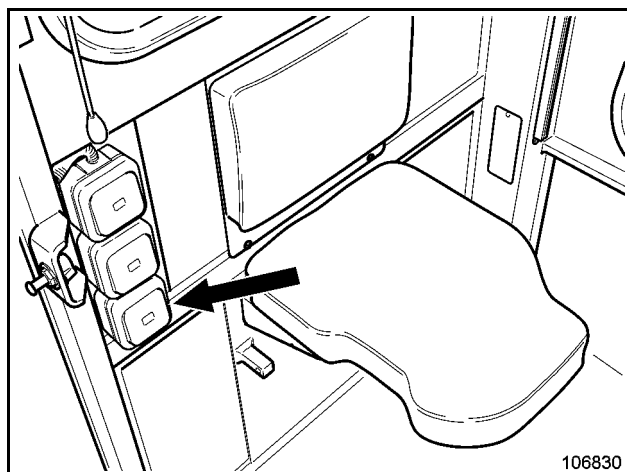

Fig. 2-31:

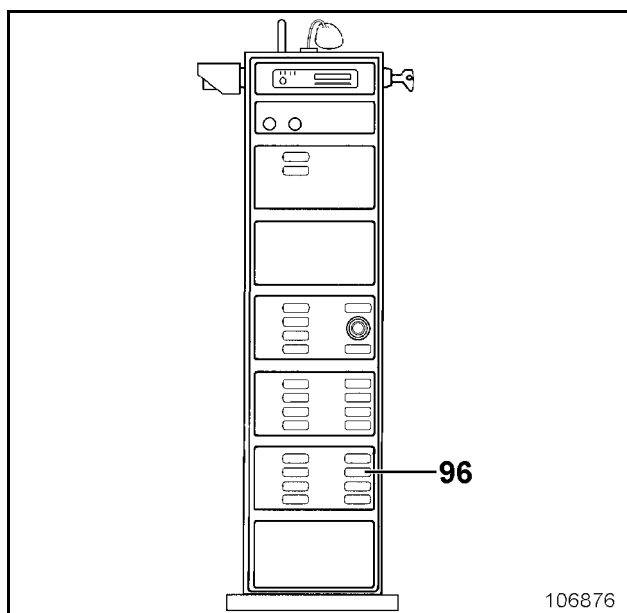

Fig. 2-32:

- Hang up loop (4, Fig. Fig. 2-54:) into snap hook (16).

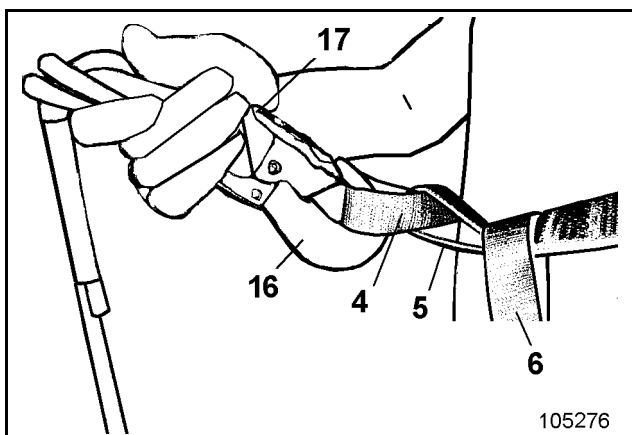

Fig. 2-54:

- Release hooking safety device (17, Fig. 2-55:).

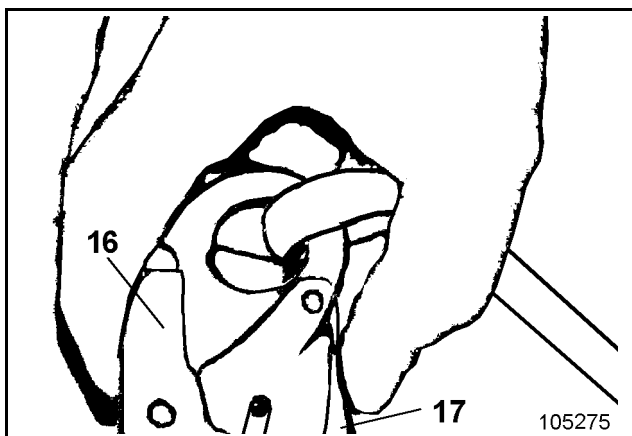

Fig. 2-55:

If you have the harness put on in such a way in case of danger you can escape from the excavator (Fig. Fig. 2-56:).

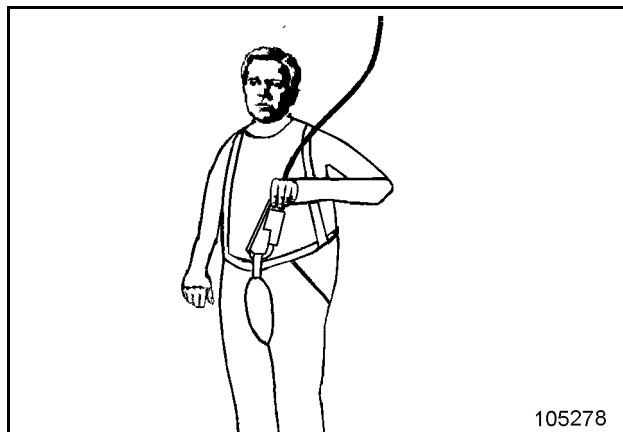







Fig. 2-56:

(Fig. 2-61:)

No.	Element	Function	Symbol
71	Switch Travel motors	Switches on the fast gear (overdrive).	
72	Switch Undercarriage holding brake	<p>CCW: brake permanently applied The excavator can not be driven</p> <p>CW: Every time the excavator stops, the undercarriage brake is automatically applied after approx. 8 sec. The undercarriage brake is automatically released when the travel function is activated.</p> <p> Actuate switch only when the excavator is stationary. Do not use as service brake.</p>	
73	Taster Reset	Activate after a fault in the central lubricating system.	
74	Switch Electronic excavator control	Switches on the electronic servo control.	
75	Switch Switching the power supply from the transformer station (optional)	Switches the power supply from the transformer station on and off.	
76	Cigarette lighter		
77	Switch	Not connected.	

(Fig. 2-66:)

(Options. Depending on the options ordered with the machine, the described elements can be found on different positions on the control column).

No.	Element	Function	Symbol
151	Warning lamp Slewing pump 1 contaminated	Lights up when the slewing pump is contaminated with metal particles.	
152	Warning lamp Slewing pump 2 contaminated	Lights up when the slewing pump is contaminated with metal particles.	
153	Warning lamp Slewing pump 3 contaminated	Lights up when the slewing pump is contaminated with metal particles.	
154	Warning lamp Slewing pump 4 contaminated	Lights up when the slewing pump is contaminated with metal particles.	
155	Warning lamp Main pump 1 contaminated	Lights up when the main pump is contaminated with metal particles.	
156	Warning lamp Main pump 2 contaminated	Lights up when the main pump is contaminated with metal particles.	
157	Warning lamp Distributor gearbox contaminated	Lights up when the distributor gearbox is contaminated with metal particles.	
158	Warning lamp Slewing pump 1 temperature	Lights up when the temperature in the slewing pump is too high	
159	Warning lamp Slewing pump 2 temperature	Lights up when the temperature in the slewing pump is too high	
160	Warning lamp Slewing pump 3 temperature	Lights up when the temperature in the slewing pump is too high	
161	Warning lamp Slewing pump 4 temperature	Lights up when the temperature in the slewing pump is too high	
162	Warning lamp Main pump 3 contaminated	Lights up when the main pump is contaminated with metal particles.	
163	Warning lamp Main pump 4 contaminated	Lights up when the main pump is contaminated with metal particles.	
164	Warning lamp Distributor gearbox contaminated	Lights up when the distributor gearbox is contaminated with metal particles.	

Circuit breaker, switching on and off

By means of the circuit breaker the supplied medium voltage 6.6kV can be connected to the excavators electrical system or can be disconnected from it. The circuit breaker is installed in the control cabinet 6.6 kV (Fig. 2-80: and Fig. 2-81:).

Switching the circuit breaker on is possible only when PLC and motor protection relay enable this function. In this case, monitoring lamp (2, Fig. 2-81:) lights up.

The circuit breaker is operated with an actuating lever which is stored in a fixture inside the control cabinet 6.6 kV.

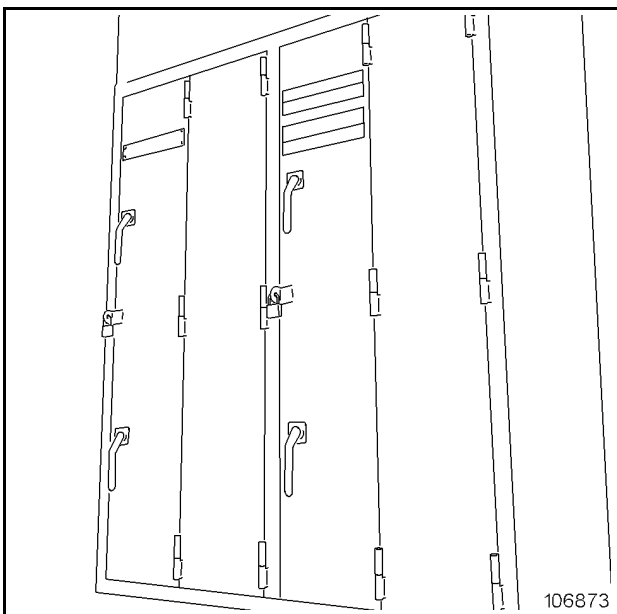

Fig. 2-80:

Switching on the circuit breaker

- Slip actuating lever (Fig. 2-82:) onto the actuating shaft of the circuit breaker. Pull locking element outwards against spring pressure.
- Turn actuating lever by ca. 180° to the left (Fig. 2-82:). This tensions the cut-out spring.
- Turn actuating lever (Fig. 2-83:) by 180° to the right. This tensions the cut-in spring and the circuit breaker is switched on.
- Engage locking ring.
- The indicator lamps "6.6 kV OK" (1, Fig. 2-84:) and "PHASE SEQUENCE OK" (2) comes on at the control cabinet 400V and at the control column in the driver's cab.
- Withdraw the actuating lever and put it into its fixture.

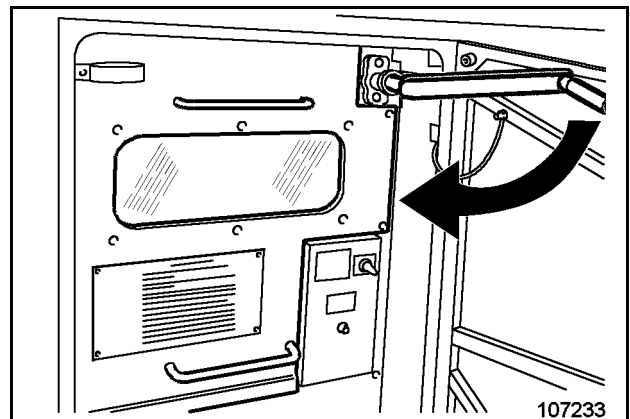

Fig. 2-82:

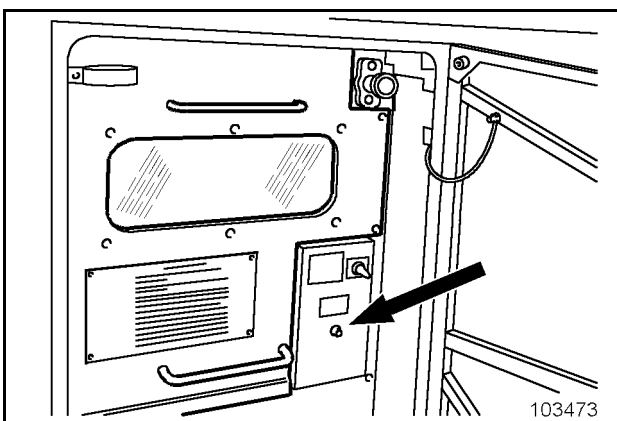

Fig. 2-81:

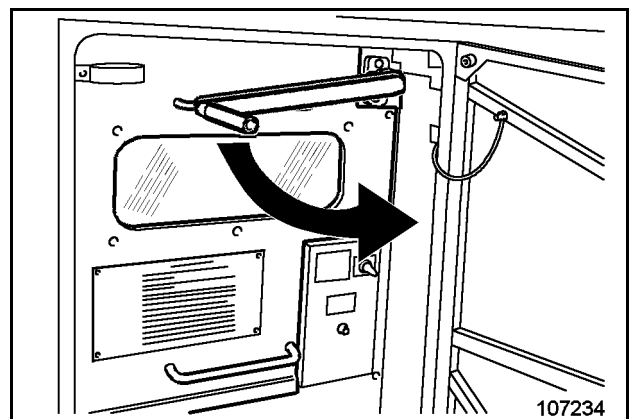

Fig. 2-83:

Travelling over long distances



Travel only forwards with the excavator in its basic position.

Travelling backwards over longer distances could damage parts of the undercarriage.

Read and observe the "Travelling – Safety instructions" chapter.

When travelling, pay attention to sufficient head-room, e. g. under cable bridges or high-tension cables.

Keep the loading or the backhoe bucket close to the ground. For a more uniform loading of the tracks, the equipment must, however, be kept at a steep angle (Fig. 2-102: / Fig. 2-103:).

Loading bucket equipment (Fig. 2-102:):

- Fully extend boom cylinder (1).
- Extend bucket cylinder (2).
- Extend stick cylinder (3).
- Retract bucket cylinder 2 and stick cylinder (3) to such an extent as to reach the position of the equipment (Fig. 2-102:).

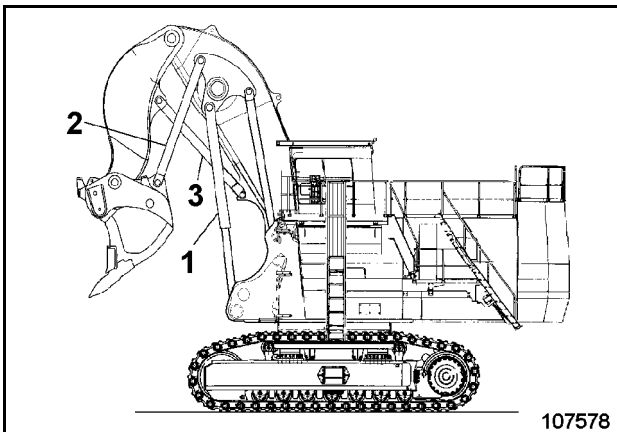

Fig. 2-102:

Backhoe bucket equipment (Fig. 2-103:)

- Fully extend boom cylinder 1.
- Retract backhoe cylinder 2.
- Retract stick cylinder 3.
- Extend backhoe cylinder 2 and stick cylinder (3) to such an extent as to reach the position of the equipment shown in (Fig. 2-103:).

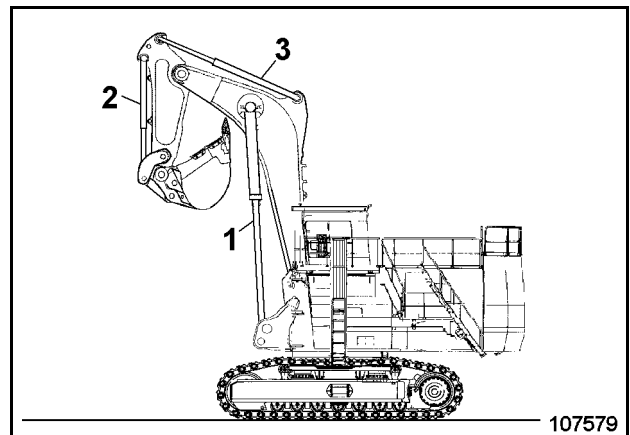

Fig. 2-103:

Lower the equipment when travelling underneath obstacles.

If the equipment position must be changed:

- stop the excavator,
- change the position,
- continue to travel.

After travelling for 15 minutes without interruption, stop the excavator and check the temperature of the track rollers.

If the temperature does not exceed ca. 100° C / 212°F, continue travelling.

In case of higher temperatures:

- Stop travelling. Resume travelling only after the track rollers have cooled down to ca. 40° C / 104°F.

CORROSION PROTECTION FOR PINS AND BEARINGS (BUSHINGS AND HUBS)

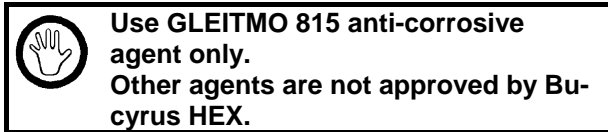

All pins and bearings (bushings and hubs) of the working equipment or in equipment components must be treated GLEITMO 815 anti-corrosive agent before fitting.

GLEITMO 815:

- permits easy fitting and dismantling,
- protects against rust, oxidation and similar wear,
- prevents seizing and fretting corrosion in non-moving parts of bearings.

This is achieved by aluminium and copper particles forming a protective layer on the metal. This layer removes surface irregularities and does not sweat, seize or harden.

Part number of GLEITMO 815 is 2764305. Available from Bucyrus HEX Spare-Parts Service

Application of GLEITMO 815

- Clean off grease, oil, dirt and corrosion protection agents from pins and bearings using white spirit or diesel fuel. Rust patches must be thoroughly removed, if any. All parts must present a dry, bright metal surface.
- Apply a thin layer of GLEITMO 815 on pins and all bearings using a brush or a spray can. Pin shafts and bearings must be completely covered by the protective layer. If the protective layer of a pin already treated with GLEITMO 815 is damaged, these areas must be touched up before fitting the part.
- Fitting and securing of pins
If the pin is too heavy to be fitted manually, apply GLEITMO 815 at first only on abt. a quarter of the pin's length
Then position pin by means of a lifting gear-ready for fitting.
Apply GLEITMO 815 on the remaining length of pin shaft, fit pin and secure.

Non-polluting disposal

Dispose of oils, greases, cooling liquids, detergents, solvents and oil-containing components, such as filters, cleaning rags, replaced wearing parts and unusable machine parts, without polluting the environment and separately from other waste.

Do not dispose of these substances together with household wastes.

Fill these substances into the containers provided for such purposes.

Like any other oil, also bio-degradable, "environmental-friendly" hydraulic oil must be disposed of separately.

Do not allow oils and oily wastes to penetrate into the soil or into water. They are an environmental hazard

Seals

Individual spares may contain asbestos. Such spares or their packaging are marked with: 

Never process spares containing asbestos mechanically. Inhaling asbestos dust is a health hazard.

Clean sealing faces prior to assembly.

Handling batteries

California Proposition 65 Warning

Battery Posts, terminals and related accessories contain lead and lead compounds, and handling batteries may also expose you to sulfuric acid mist, chemicals known to the state of California to cause cancer and reproductive harm. Wash hands after handling.

Batteries give off explosive gases.

Never handle batteries close to naked flames and unshielded light sources, never smoke.

Battery acid is toxic and corrosive.

Avoid any contact with the skin, mouth, eyes and clothing. Avoid spilling battery acid or inhaling the vapours.

Wear gloves, firm protective clothing and goggles when handling batteries.

If the skin is splashed with acid, rinse thoroughly with running water and consult a doctor.

If the eyes are splashed with acid, rinse thoroughly with running water and consult a doctor immediately.

Never set tools down on the battery. They may induce a short circuit, causing irreparable damage to the battery and injuring persons.

Never wear metal necklaces, bracelets or watchstraps when working on the battery. The metal parts may induce a short-circuit resulting in burns.

Dispose of used batteries separately from other waste in the interests of environmental protection.

Before working on the electrical system

Before performing work on the electrical system where tools, spare parts, etc. can come into contact with electrical conductors or contacts, the battery must be disconnected.

Disconnect first the negative and then the positive terminal.

After the work:

Reconnect first the positive and then the negative terminal.

CLICK HERE TO **DOWNLOAD** THE COMPLETE MANUAL

- Thank you very much for reading the preview of the manual.
- You can download the complete manual from: www.heydownloads.com by clicking the link below



- Please note: If there is no response to CLICKING the link, please download this PDF first and then click on it.

CLICK HERE TO **DOWNLOAD** THE COMPLETE MANUAL

Plan T and W

Plan **T** - Every 10 OH or every working shift

(whichever comes first)

Plan **W** - Every 60 OH or every working week

(whichever comes first)

Page 1 of 2

Location	Servicing work	Quantity/ No.	Plan T	Plan W
Electric motor	Listen for unusual machine noise	1		●
Electrical system				
Lighting	Check operation		●	●
Switchgear cabinets	Check for condensation/drain water		●	●
- Electrical components	Visual check			●
Switchgear cabinets				
- Breather filters				
- Dust traps	Remove dust	3		●
- EMERGENCY OFF switches	Check function	3		●
Monitoring, warning and control elements	Check function of monitoring, warning and control elements		●	●
BCS	Check function	1	●	●
Hydraulic system	Check function of working and travelling movement		●	●
	Inspect visually for leaks			●
Hydraulic oil reservoir	Check oil level	1	●	●
Oil cooler	Check / clean	2		●
Fan wheel	Check condition	2	●	●
Pump transfer gearbox	Check oil level	1		●
Oil filter (tell-tale)	Check	1		●
Swing gearbox	Check oil level	4	●	●
Reservoir for used grease at the A-frame	Check, depollute used grease	2 x 1		●
Travel gearbox	Check for leaks	2	●	●
Escape ladder				
- Locking	Check function		●	●
- Ladder	Check free movement		●	●
Emergency escape device / seat	Visual condition check		●	●
- Holding device	Check tightness and fixation on cab		●	●
- Harness	Connect to the holding device		●	●

No.	Greasing point	Number	Lubricant properties	Grease every operating hours
1	Central lubricating system – grease container	1	V ¹²	10
2	Hydraulic ladder, central greasing point	1		1000
3	Electric motor, bearings	2 x 1	V ¹²	See plate with lubricating instructions attached to the electric motor for detailed information).
5	On-board crane		V ¹²	250
	- Bearing	4		250
	- Joint (column / boom)	2		250
	- Cylinder bearing	5	250	
	- Swing ring	1	Graphitspray	250
6	Monitoring, warning and control elements		V ¹²	
	- Joystick	2 x 4 ¹³		1000
	- Pedal	3 x 2 ¹³		1000

All other greasing points are supplied with grease by the central lubricating system.

Filling quantities – Grease

Greasing point	Lubricant properties	Filling quant. in	
		kg	lb
Central lubricating system – grease container (Depending on the ordered system the volume may vary)	V ¹²	appr. 180 to 1000 litres	appr. 47.5 to 264 gal
Internal gearing – Roller-bearing swing ring		appr. 300	appr. 661
Idler (permanent grease filling)	Tribol BUCYRUS HEX part no. 2764564	2 x appr. 25	2 x appr. 55
Track rollers (permanent grease filling) (optional: rollers supported with grease via the central lubrication system for the undercarriage)		12 x appr. 21	12 x appr. 46
Support rollers (permanent grease filling)		4 x appr. 14	4 x appr. 31

¹² see "LUBRICANTS" section

¹³ apply a thin layer of low temperature grease

V. Greases for bearings and swing rings

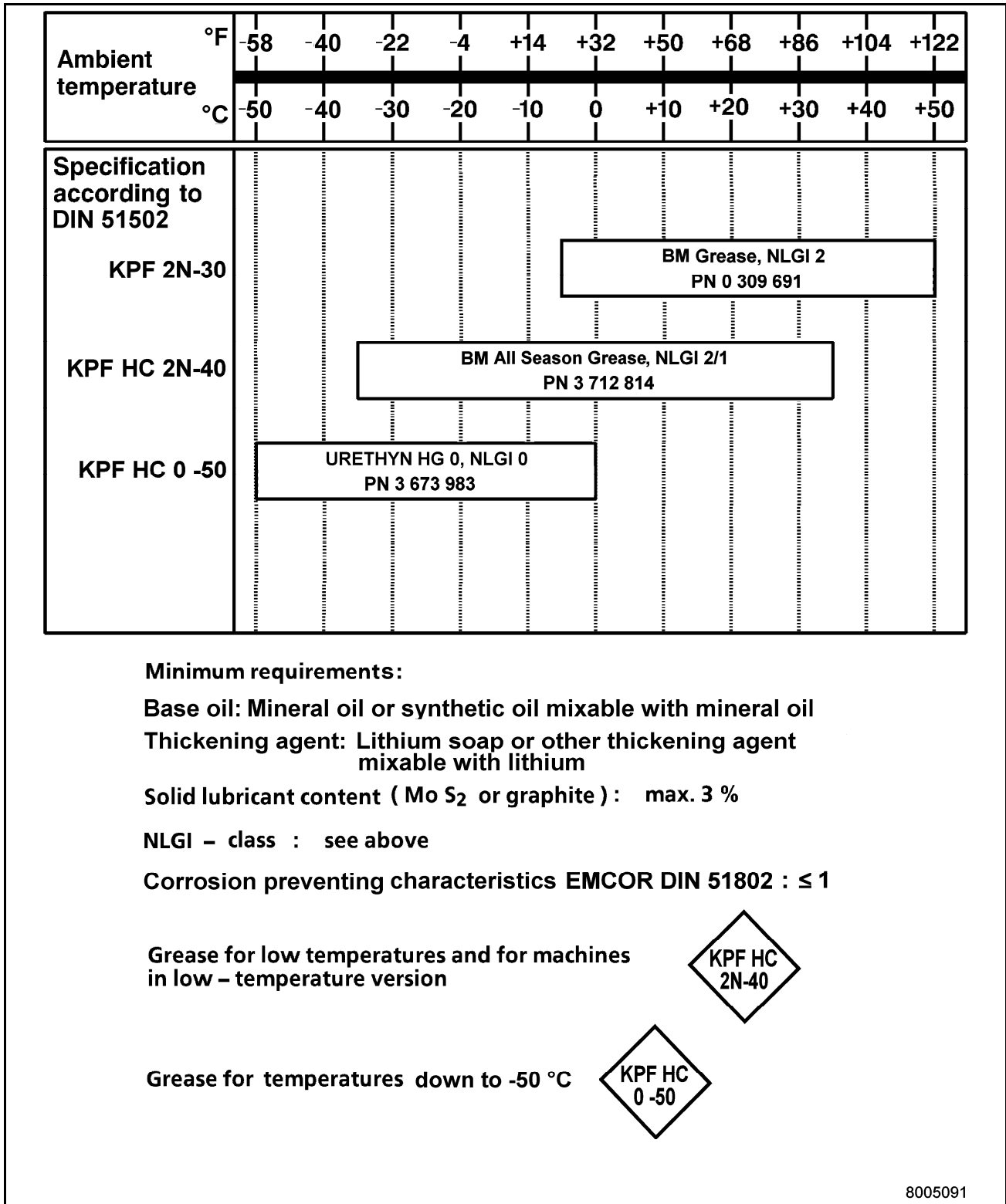

Fig. 3-14:

Floodlight projector, replacing the lamp

Safety instructions

The floodlight projectors use xenon technology. The lamp is not a usual incandescent lamp, but a gas discharge lamp which is operated with a ballast unit. The ballast unit is integrated in the floodlight projector.

When the projector is turned on, the ballast unit generates a high-voltage pulse of more than 25000 volts to start the xenon lamp.



Warning!

This high-voltage pulse can be a life-threatening risk, if a person comes into contact with any of the live components. This can be the case, for instance,

- if the lamp is operated improperly,
- if the projector housing is opened in an inappropriate way or
- by sticking one's hand into an opened or damaged projector.

Protect yourself from potential risks by reading and by observing the following safety instructions.



Always switch off the projector and disconnect it from its power supply before replacing the Xenon lamp.

Allow the xenon lamp to cool off before removing it from the projector.

Wear goggles and safety gloves when replacing the lamp.

Never stick your hand into the lampholder. The contacts may still be live with residual voltage.

Never switch on the projector when the xenon lamp has been removed. There is a risk of voltage discharge and damage to the lampholder.

The glass body of the xenon lamp is filled with different gases and metal gases and is under gauge pressure (risk of injury from splinters)

If the xenon lamp breaks apart in closed room (workshop), all persons must leave the room and the room must be ventilated for at least 20 minutes to exclude any health risks caused by gases.

Further instructions

Always hold the xenon lamp by the base. Never touch the glass bulb. Sweat and grease from the skin would evaporate when the lamp is in operation and obscure the reflector.

If the fingers have nevertheless come into contact with the glass bulb, the fingerprints must be removed with a clean cloth and some alcohol.

The replaced Xenon lamp must be disposed of as special waste.

Never switch on projectors when housing or electrical wiring is damaged.

Have damaged projectors be replaced by a qualified electrician as soon as possible.

Filter (servo control circuit), replace



Risk of scalding caused by hot hydraulic oil.

Read and observe the "Inspection and servicing - Safety instructions" chapter.

Switch off the electric motor.

The hydraulic oil reservoir itself may also be hot.

Avoid skin contact.

Skin contact with hydraulic oil may cause skin injury.

Wear protective gloves and firm working clothing.

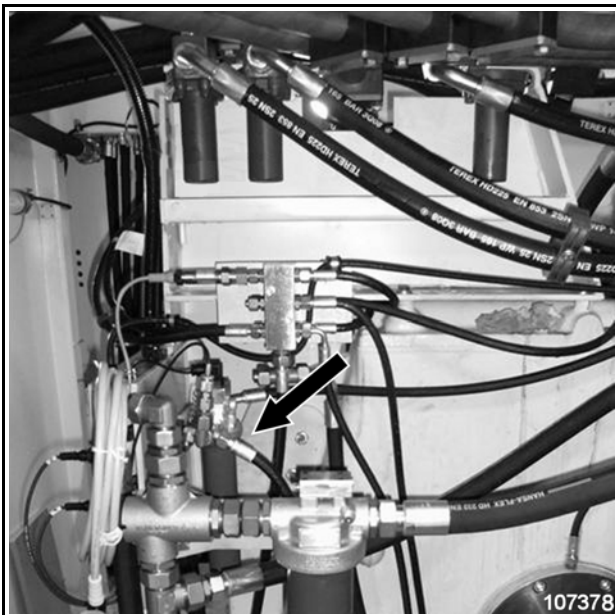

Fig. 3-49:

Replacing the filter element

To filter the hydraulic oil in the control circuit, the machine is equipped with a high-pressure filter (arrow, Fig. 3-49:).

Change filter element regularly and when the BCS indicates a contamination.

- Unscrew filter housing (5, Fig. 3-50:).
- Withdraw filter element (6) from filter housing (5).
- Clean filter housing (5) and the sealing face at the filter head with white spirit or paraffin oil.
- Check seals (8) and replace, if required.
- Insert new filter element into filter housing (5) and refit to the filter head with new, lightly oiled sealing ring (8).
- Check for leaks after putting the filter into operation.

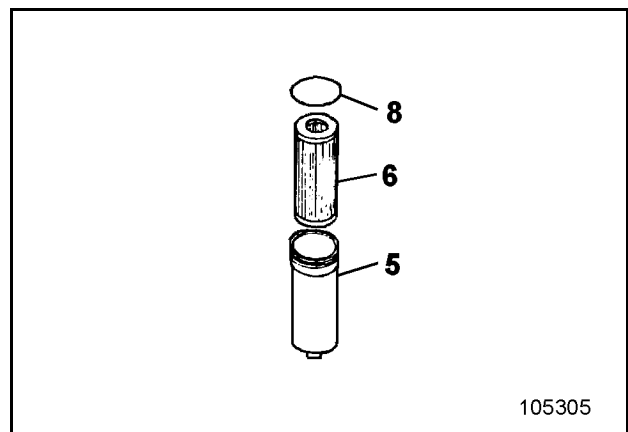

Fig. 3-50:

Electronic excavator control

Joystick

At regular intervals acc. to the maintenance plans:

- Loosen gaiter and move upwards.
- Apply a thin layer of low temperature grease on the control spools, the actuator plate above and the cardan joint of the joysticks (arrows, Fig. 3-67:) to prevent jamming of the joysticks.
- Refit gaiter using a cable strap.

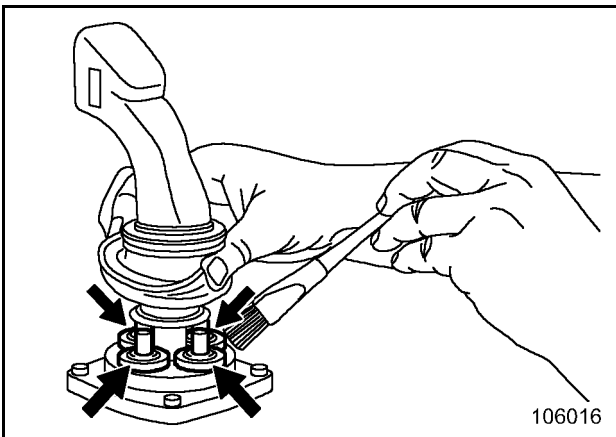

Fig. 3-67:

Pedal

At regular intervals acc. to the maintenance plans:

- Remove old grease and dirt from the control spools and the actuator plate of the pedals (arrows, Fig. 3-68:).
- Apply a thin layer of low temperature grease on the control spools of the pedals to prevent jamming of the control spools.

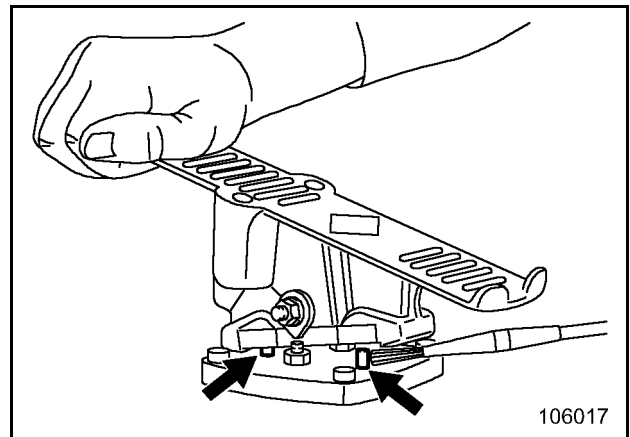

Fig. 3-68:

Travel gearbox - Changing oil

Carry out oil change when oil is nearly at operating temperature. All suspended particles and contaminations will be rinsed out with the old oil.

Draining off oil

- Move the excavator into such a position that the screw plugs (1, 2 and 3, Fig. 3-86:) are in the displayed position.
- Place a collecting recipient for used oil under the travel gearbox.
Choose the required capacity in accordance with the "Refilling quantities - Oil" table.
- Unscrew drain plug (2) and drain off the oil completely.
Slackening plug (3) allows the oil to run out more readily.
- Clean screw plugs (2 and 3)
- Screw screw plug (2) back in place.

Filling in oil

- Unscrew screw plug (1 and 3).
- Fill in oil through opening in plug (3) until it flows out of opening in plug (1).
Oil grade see: „LUBRICANTS“.
- Screw plugs (1 and 3) back in place.

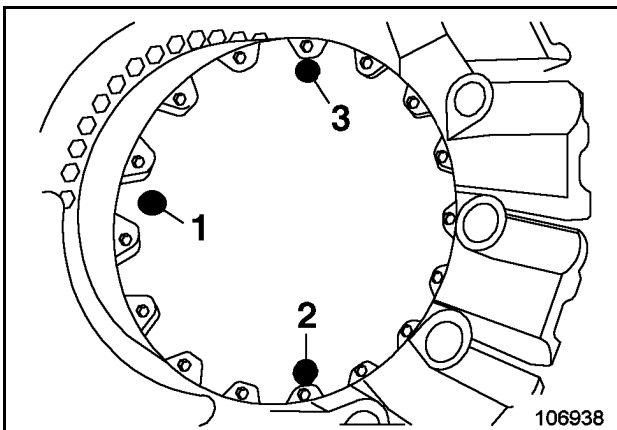

Fig. 3-86:

Spur gear section - Changing the oil / Draining off oil

- Place a collecting recipient for used oil under the pre-chamber.
Choose the required capacity in accordance with the "Refilling quantities - Oil" table.
- Unscrew drain plug (3, Fig. 3-87:) and drain off the oil completely.
Slackening plug (4) allows the oil to run out more readily.
- Clean screw plugs (3 and 4)
- Screw screw plug (3) back in place.

Filling in oil

- Unscrew screw plug (4).
- Fill in oil through opening of plug (4) until it reaches the center of the inspection glass (2).
Oil grade see: „LUBRICANTS“.
- Screw plug (4) back in place.

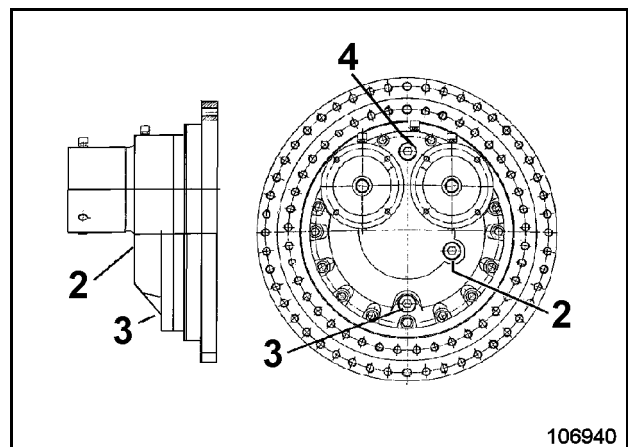

Fig. 3-87:

SWING RING



Switch off the electric motor

Wear protective gloves and firm protective clothing.

Swing ring - Instructions

The grease filling must be replaced:

- when repairs have been carried out on the swing ring, the swing ring seals or the swing ring housing.

Remove old grease completely before filling in new grease.

If greater losses are detected, locate cause immediately to prevent damage to the swing ring. Greases and greasy cleaning rags must not be allowed to pollute the environment. Discard grease and greasy cleaning rags separately from other waste without polluting the environment.

Bearing races

The **central lubricating system** supplies grease continuously to the two **roller bearing races** and the **internal gearing**.

The grease is pumped to the greasing points of the bearing races by a distributor (Fig. 3-102:).

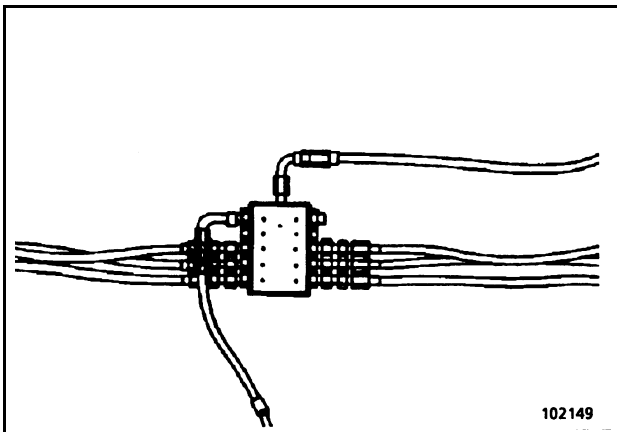

Fig. 3-102:

Internal gearing

The internal gearing (1, Fig. 3-103:) and the pinion (2) are enclosed in a housing (3, Fig. 3-104:). The housing forms a grease-filled trough in which the pinion of the swing mechanism moves.

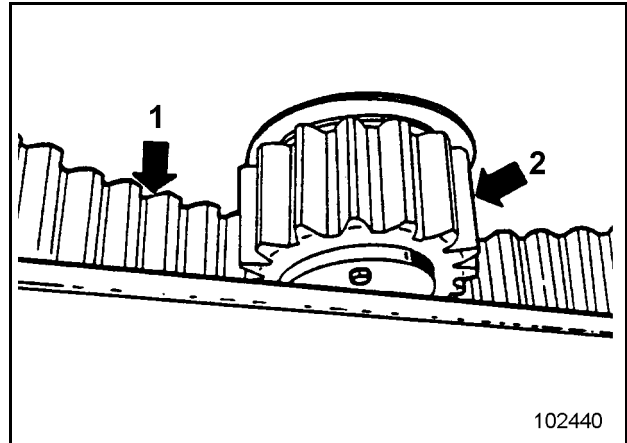

Fig. 3-103:

The grease is pumped to the greasing port of the grease trough by the distributor (Fig. 3-102:). The amount of grease used up during operation is replenished by the central lubricating system.

The housings have a check opening which is closed with a cover (2, Fig. 3-104:). For checking, the cover must be removed.

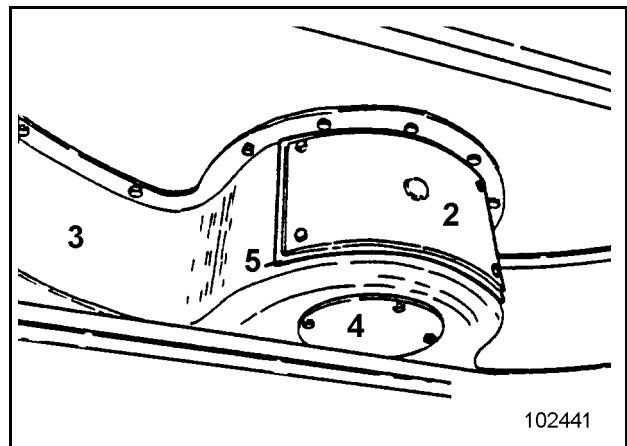

Fig. 3-104:

Grease filter (Grease lines)



Switch off the electric motor.

Grease filter (12, Fig. 3-124:) is installed in the greasing line to the grease container.

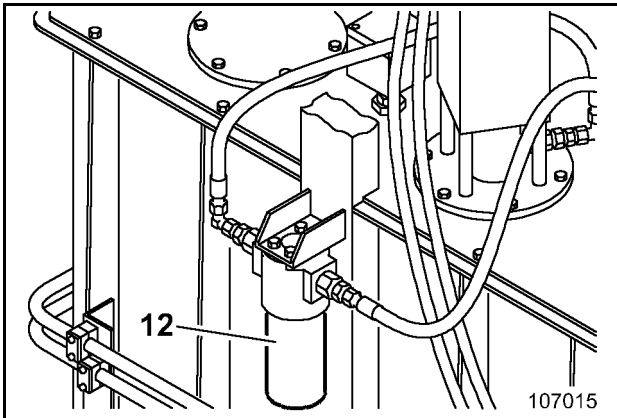

Fig. 3-124:

Checking the filter element

- Unscrew filter housing (42, Fig. 3-125:).
- Withdraw filter element (43) from housing (42).
- Remove the grease.
- Clean filter housing and contact faces at the filter head with white spirit or paraffin oil.
- Insert filter element into housing (42) and attach to the filter head with a new, slightly oiled sealing ring (46).
- Check the high-pressure filter for leaks after the system has been put into operation.

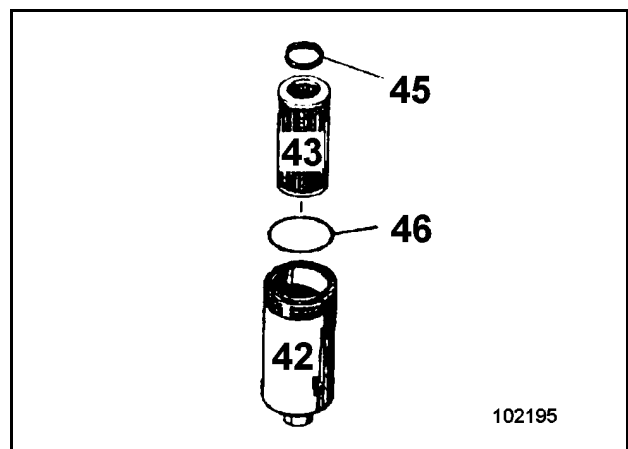

Fig. 3-125:

Replacing the filter element

- Remove filter element as described under "Checking the filter element".
- Insert new filter element and reassemble.
- Check high-pressure filter for leaks after the system has been put into operation.

4 REPAIR WORK

	Operating instructions	Target group
Part 1	INTRODUCTION FUNDAMENTAL SAFETY INSTRUCTIONS	Operating personnel + Inspection and servicing personnel + Repair personnel
Part 2	OPERATION	Operating personnel The operating personnel must have know-how relevant to the operation and the application of this or comparable machines.
Part 3	INSPECTION AND SERVICING	Inspection and servicing personnel The inspection and servicing personnel must have know-how relevant to the inspection and servicing of this or comparable machines.
Part 4	REPAIR WORK	Repair personnel The repair personnel must have know-how and experience relevant to the repair of this or comparable machines.
Part 5	ANNEX	Operating personnel + Inspection and servicing personnel + Repair personnel
Part 6	INDEX	Operating personnel + Inspection and servicing personnel + Repair personnel

Tanks, pressure vessels and pressure accumulators

Any work on vessels containing or having contained

- combustible or combustion-accelerating substances,
- potentially explosive substances or
- substances susceptible to develop harmful gases, fumes, mists or dusts during welding

may only be carried out under expert supervision and only by experienced personnel especially assigned to such work.

This prescription applies, for instance, to all tanks and reservoirs for hydraulic fluid, engine oil, diesel fuel or lubricating grease.

Welding work on pressure vessels and pressure accumulators is forbidden.

Pressure vessels containing cold-starting fluid (ether) may be installed in or near the engine compartment.

Ether is toxic and highly flammable; the vessels are under pressure. These pressure vessels can explode if exposed to high temperatures (above 49°C / 120°F) or in the event of damage.

Protect the vessels against damage and high temperatures.

Do not perform welding work in the vicinity of these pressure vessels before they have been covered up safely against accidental contact or flying sparks. Have the pressure vessels removed from the machine, if safe protection cannot be ensured.

Inform yourself about the locations in the machine where the pressure accumulators of the hydraulic system are installed. Do not perform welding work in the vicinity of these pressure accumulators before they have been covered up safely against accidental contact or flying sparks. Have the pressure accumulators removed from the machine, if safe protection cannot be ensured.

Slewing rings and articulated joints

The welding current must not flow through ball-bearing or roller-bearing slewings rings, through bolted connections or articulated joints or through hydraulic cylinders.

An electric current flowing through an air gap (e.g. in the bearing or in the articulation) produces a spark which damages the metallic surface.

The welding clamps must therefore always be connected very close to the weld area (max. 2 - 3 m away (6.6-9.8 ft)).

Information relating to the electrical system and to electronic modules

Electric arc welding produces electromagnetic fields, electrostatic charges and voltage spikes which can cause damage to electronic modules. Although the electronic modules of the machine are carefully protected against these influences, it is nevertheless necessary to take additional precautions in order to prevent such damage to the greatest possible extent.

Switch off the electrical system ("ignition OFF").

Open the battery main switch (or disconnect the starter batteries from the machine).

Lay the welding cables as far away from electric lines as possible.

If it is not possible to implement all of the above-mentioned precautions, all connectors must be removed from the electronic modules before beginning any welding work.

Protect withdrawn terminals and connectors from short circuits and soiling. Cover up terminals and connectors with foils or adhesive tape.

Never touch the enclosures of electrical and electronic modules with the welding electrode.

Protect electric lines against the heat emanating from the weld area.

Restore all electrical connections when the welding operations are terminated.

Never connect the ground clamp of the welding cable to the enclosures of electric or electronic modules.

Track drive – Fault table

Fault				Remedial action
No forward travel and no reversing travel				Check P
Maximum travel speed cannot be reached				Adjust E
Insufficient traction power				Replace W
				Top up A
				Reduce S
				Clean R
				1) Contact the Bucyrus HEX Service
Cause				Chapter ref.
•	•	•	Malfunction of pressure-relief valves	1)
•	•	•	Servo system pump defective	1)
•	•	•	Malfunction of travel valve (pedal)	1)
	•	•	Malfunction of control spool	1)
	•		ECO-power switch in 80%-position	Travelling P
	•		Hydraulic oil temperatur too high (warning lamp lit, PMS fault indicator lamp lit) oil cooler contaminated	Hydraulic oil cooler cleaning P/R

Hydraulic Shovel—6060

Version 2 - Cummins® QSK45 Tier 1

Make and model	2 x Cummins QSK45
Total rated net power ISO	3 046/1 2 240 kW (3 000 HP) 1,800 min ⁻¹
Total rated net power SAE J1349	2 240 kW (3,000 HP) 1 800 min ⁻¹
Total rated gross power SAE J1995	2 240 kW (3,000 HP) 1 800 min ⁻¹
No. of cylinders (each engine)	12
Bore	159 mm (6.25 in)
Stroke	190 mm (7.48 in)
Displacement	45 l (2,746 in ³)
Aspiration	Turbocharged and aftercooled
Max. altitude without deration	4 267 m (14,000 ft) a.s.l.
Alternators	2 x 175 A

Hydraulic System with Pump Managing System

Main pumps	4 x swash plate double pumps
Max. oil flow	4 x 1 300 l/min (4 x 343 US gal/min)
Max. pressure, attachment	32 MPa = 320 bar (4,640 psi)
Max. pressure, travel	37 MPa = 370 bar (5,370 psi)
Swing pumps	4 x reversible swash plate pumps
Max. oil flow	4 x 352 l/min (4 x 93 US gal/min)
Max. pressure, swing system	32 MPa = 320 bar (4,640 psi)
Total volume of hydraulic oil	approx. 9 400 l (2,483 US gal)
Hydraulic tank capacity	approx. 7 100 l (1,876 US gal)

- Pump Managing System contains:
 - Electronic load limit control
 - Flow on demand from main pumps depending on joystick position
 - Automatic regulation of main pumps to zero flow without demand
 - Automatic rpm reduction of engine speed during working breaks
 - Reduced oil flow of main pumps at high hydraulic oil temperature or engine temperature
 - Pressure cut-off for main pumps
 - Cooling of pump transmission gear oil
 - Filters:
 - Full-flow high-pressure filters (100 µm) for the main pumps, installed directly behind each pump
 - High pressure filters (200 µm) for the closed swing circuit
 - Full-flow filters (10 µm) for the complete return circuit
 - Pressure filters (40 µm and 6 µm) for servo circuit
 - Pressure filters (40 µm) for the feed pumps of the closed swing circuit
 - Transmission oil filters (40 µm)

Undercarriage

Travel speeds (2 stage)	1st stage 2nd stage	Max. 1.4 km/h (0.87 mph) Max. 2.0 km/h (1.24 mph)
Max. tractive force	2 956 kN (301 t = 664,300 lb)	
Gradability of travel drives	Max. 52 %	
Track pads (each side)	42	
Bottom rollers (each side)	7	
Support rollers (each side)	2 plus a skid plate in between	
Travel drives (each side)	1 planetary transmission with 2 two-stage axial piston motors	
Parking brakes	Wet multiple-disc brake, spring applied/hydraulically released	

- Cast double-grouser combined pad links with bushings connected by hardened full floating pins
- All running surfaces of sprockets, idlers, rollers and pad links, as well as teeth contact areas of sprocket and pad links, are hardened
- Fully hydraulic, self-adjusting track tensioning system with membrane accumulator
- Automatic hydraulic retarder valve to prevent over-speed on downhill travel
- Acoustic travel alarm

Operator's Cab

Operator's eye level	approx. 7.6 m (24 ft 11 in)	
Internal dimensions cab	Length	2 200 mm (7 ft 3 in)
	Width	1 600 mm (5 ft 3 in)
	Height	2 150 mm (7 ft 1 in)

- Pneumatically cushioned and multi-adjustable comfort seat with lumbar support, safety belt, head and armrests
- Switch in seat cushion to automatically neutralize the hydraulic controls when operator leaves the seat
- Joystick controls integrated in independently adjustable seat consoles
- Fold-away auxiliary seat with safety belt
- FOPS (rock guard; approved acc. to DIN ISO 3449) integrated into cab structure
- All-round safety glass, armored windshield and sliding side window
- Windshield with parallel intermittent wiper/washer
- Roller blind at windshield
- Robust instrument panel incl. large colored BCS screen with transfective technology
- Board Control System (BCS) electronic monitoring and data logging system for vital signs and service data of engines, hydraulic system and lubrication system
- Machine access via retractable boarding ladder, hydraulically operated
- Sliding emergency ladder (kick-down type) with ladder cage

CLICK HERE TO **DOWNLOAD** THE COMPLETE MANUAL

- Thank you very much for reading the preview of the manual.
- You can download the complete manual from: www.heydownloads.com by clicking the link below



- Please note: If there is no response to CLICKING the link, please download this PDF first and then click on it.

CLICK HERE TO **DOWNLOAD** THE COMPLETE MANUAL