

Front PTO Kit

Package With: RE326849



JOHN DEERE

INSTALLATION INSTRUCTIONS

Front PTO Kit

RE326854 16JUN15 (ENGLISH)

7R Series Tractors

John Deere Waterloo Works
RE326854 (16JUN15)

PRINTED IN U.S.A.
COPYRIGHT © 2014
DEERE & COMPANY
Moline, Illinois

All rights reserved.
A John Deere ILLUSTRATION™ Manual

RE326854-19-16JUN15

CLICK HERE TO **DOWNLOAD** THE COMPLETE MANUAL

- Thank you very much for reading the preview of the manual.
- You can download the complete manual from: www.heydownloads.com by clicking the link below



- Please note: If there is no response to CLICKING the link, please download this PDF first and then click on it.

CLICK HERE TO **DOWNLOAD** THE COMPLETE MANUAL

18. Attach nylon straps (D) around rear hood support and through opening in hood.
19. Attach straps to overhead hoist as illustrated.
20. Disconnect harness (A).
21. Remove rear linkage pin (B).
22. Remove front linkage pin (C) and lift hood off tractor.

A—Harness Connector
B—Rear Linkage Pin

C—Front Linkage Pin
D—Lifting Straps

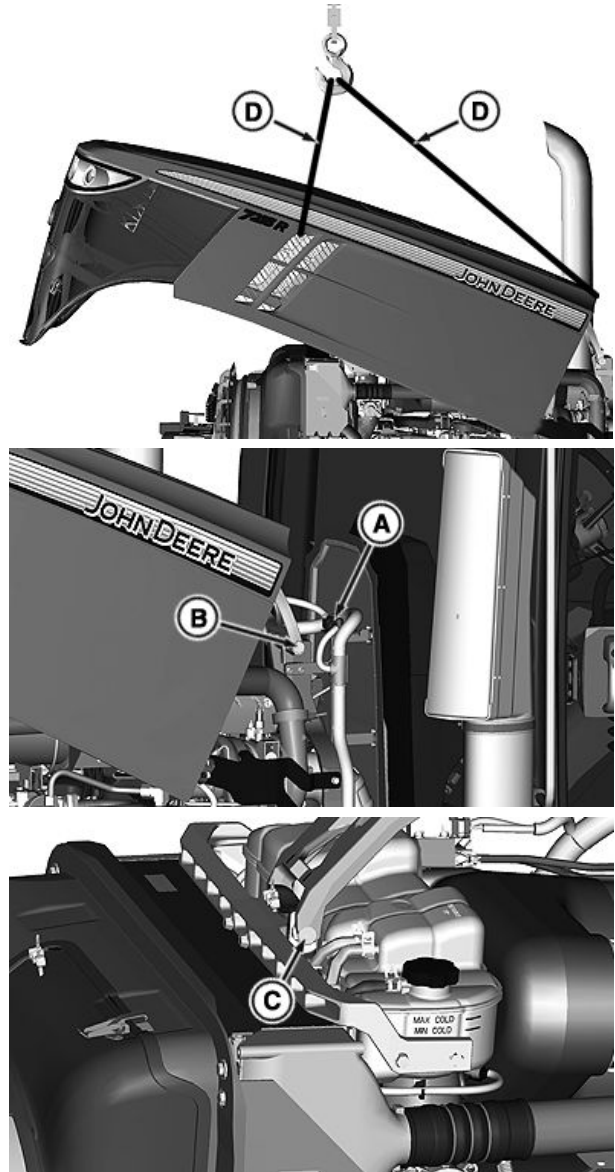

RXA0112172 —UN—07DEC10

RXA0112187 —UN—07DEC10

RXA0112165 —UN—07DEC10

Continued on next page

AS67992,00000FA -19-16JUN15-7/71

63. Remove cap screws (A) and charge air cooler (B).

A— Cap Screws (4 used)

B— Charge Air Cooler

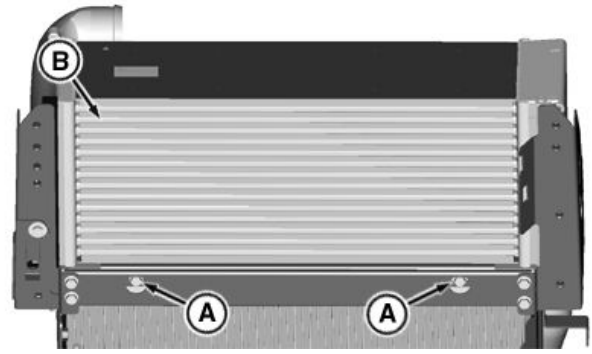

RXA0115924—UN—15APR11

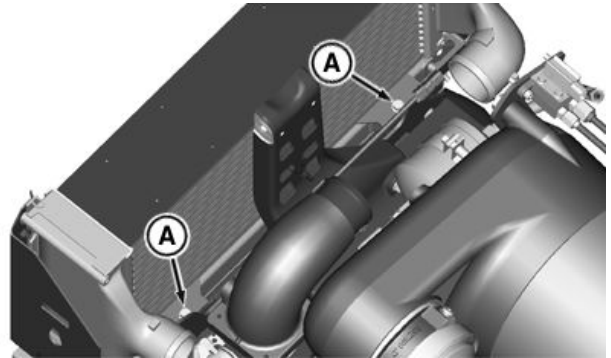

RXA0115930—UN—15APR11

Continued on next page

AS67992,00000FA -19-16JUN15-24/71

95. Install cap screws (A) and spacers (B). Tighten to specification.

Specification

Front PTO Mounting Cap

Screws—Torque.....430 N·m
(317 lb.-ft.)

A— Cap Screws (4 used)

C—Bushings (2 Used)

B— Washers (4 used)

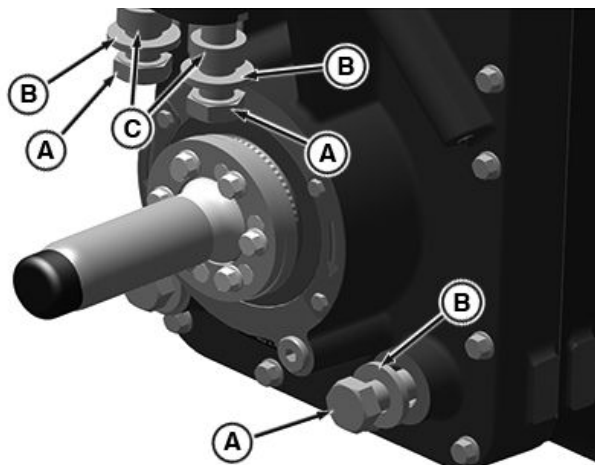

PY24437 —UN—04JUN15

AS67992,00000FA -19-16JUN15-41/71

96. Install PTO stub shaft (A) with six cap screws (B). Torque to specification.

Specification

Cap Screw (B)—Torque.....28 N·m
(20 lb.-ft.)

A—Shaft

B—Cap Screw

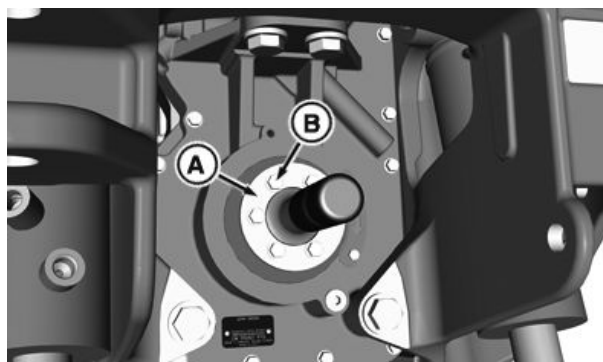

RXA0136510 —UN—05NOV13

AS67992,00000FA -19-16JUN15-42/71

97. Connect wiring harness (A).

A— Harness Connectors (4 used)

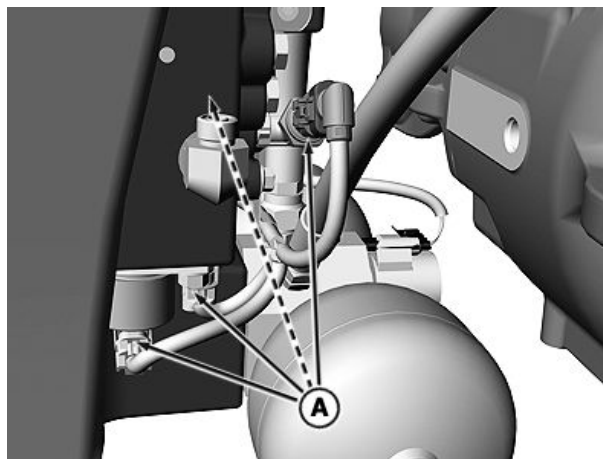

RXA0116653 —UN—13MAY11

Continued on next page

AS67992,00000FA -19-16JUN15-43/71

IMPORTANT: Verify that R327584 friction washer is installed on shaft before front PTO drive pulley is installed.

127. Install R327584 friction washer, drive pulley, and cap screws (E). Tighten to specification.

Specification

Drive Pulley-to-Shaft	
Mounting Cap	
Screws—Torque.....	85 N·m
	(63 lb.-ft.)

128. Install alternator and cap screws (D).

129. Install engine control unit and cap screws (C).

130. Install fuel coolers, shield (B), and cap screws (A).

- | | |
|------------------------|------------------------|
| A— Cap Screws (7 used) | D— Cap Screws (2 used) |
| B— Shield | E— Cap Screws (3 used) |
| C— Cap Screws (6 used) | |

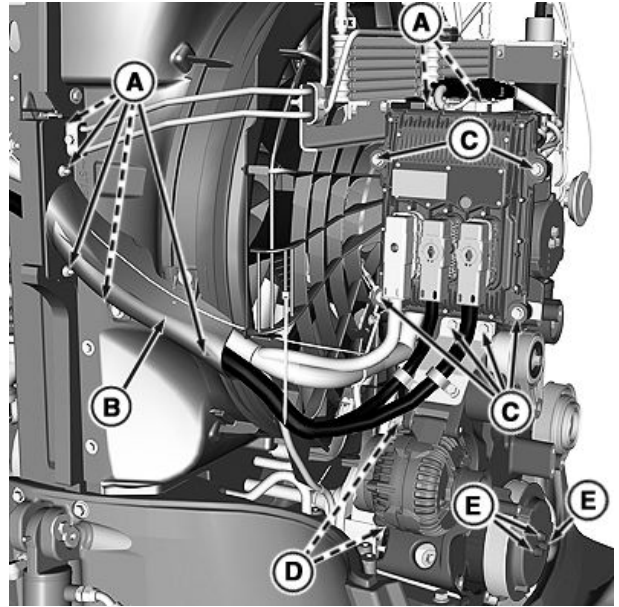

RXA0116544—UN—13MAY11

AS67992,00000FA -19-16JUN15-57/71

131. Release tension on belt using long-handle 1/2 in. drive tool (A) on tensioner pulley (B).

132. Install belt.

- | | |
|----------------------------------|------------------|
| A—Long-Handle 1/2 in. Drive Tool | B—Belt Tensioner |
|----------------------------------|------------------|

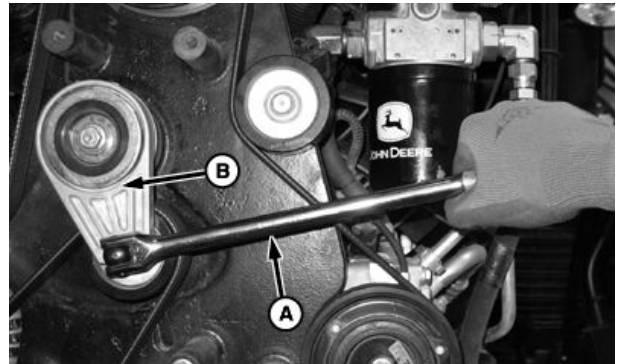

RXA0109509—UN—19AUG10

AS67992,00000FA -19-16JUN15-58/71

133. Install auxiliary drive shield (B) and cap screws (A).

- | | |
|-----------------------|--------------------------|
| A—Cap Screws (4 used) | B—Auxiliary Drive Shield |
|-----------------------|--------------------------|

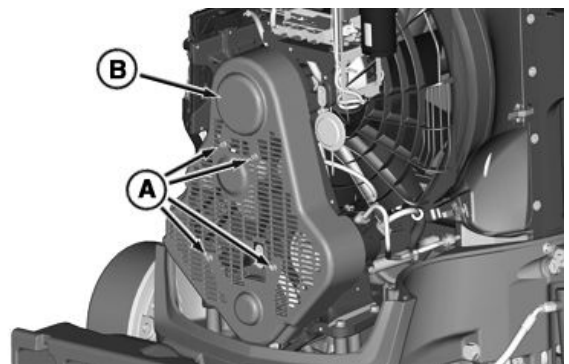

RXA0113919—UN—06APR11

Continued on next page

AS67992,00000FA -19-16JUN15-59/71

4. Remove cap screws (A), right rear upholstery (B), and rubber seal (C).

A— Cap Screw
B— Rear Right Upholstery

C— Rubber Seal



RXA0115396 —UN—12APR11

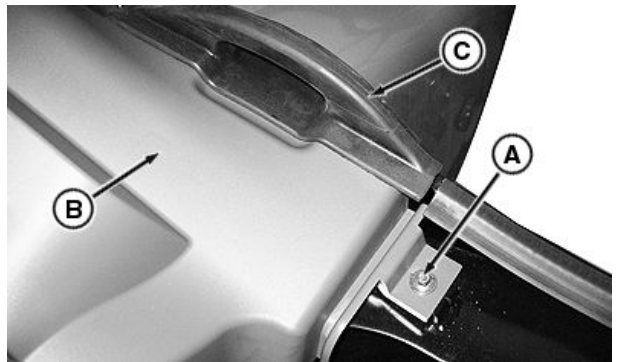

RXA0115398 —UN—12APR11

Continued on next page

CB33994,0000AA1 -19-22AUG14-2/7

CLICK HERE TO **DOWNLOAD** THE COMPLETE MANUAL

- Thank you very much for reading the preview of the manual.
- You can download the complete manual from: www.heydownloads.com by clicking the link below



- Please note: If there is no response to CLICKING the link, please download this PDF first and then click on it.

CLICK HERE TO **DOWNLOAD** THE COMPLETE MANUAL