



INSTALLATION INSTRUCTIONS

KG1BP589-00
QUICK COUPLER LINE KIT (FOR STANDARD BOOM)

APPROXIMATE INSTALLATION TIME: 8.0 hours

CLICK HERE TO **DOWNLOAD** THE COMPLETE MANUAL

- Thank you very much for reading the preview of the manual.
- You can download the complete manual from: www.heydownloads.com by clicking the link below



- Please note: If there is no response to CLICKING the link, please download this PDF first and then click on it.

CLICK HERE TO **DOWNLOAD** THE COMPLETE MANUAL

7. Install the pipe clamp (17) and seating (boom top, QC) (4) with two sems bolts (9).
Install the two screw caps (10) on the seating (boom top, QC) (4).
Fasten the line assembly (left) (12) and line assembly (right) (14) with the pipe clamp (16) and sems bolt (8).

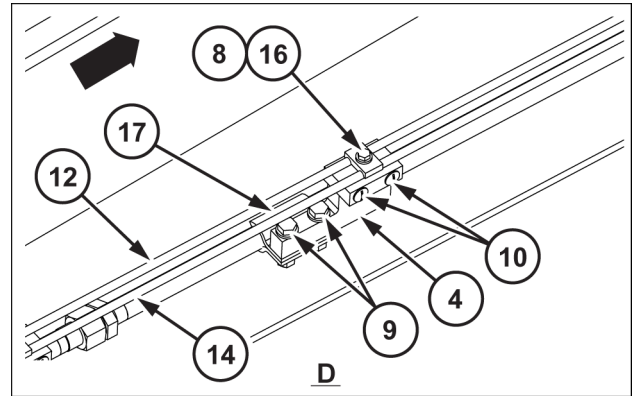

SMIL15CEX8408AB 8

8. Install the seating (boom top, QC) (4) with two sems bolts (9).
Install the two screw caps (10) on the seating (boom top, QC) (4).
Fasten the line assembly (left) (12) and line assembly (right) (14) with the pipe clamp (16) and sems bolt (8).
Sandwich the line assembly (left) (12) with the seating (stopper, BU, QC) (1) and pipe clamp (15), and then fasten with the high-strength bolt (22).

- Fasten the seating (stopper BU QC) (1) at a position **1000 mm (39.370 in)** from the pipe clamp (16).

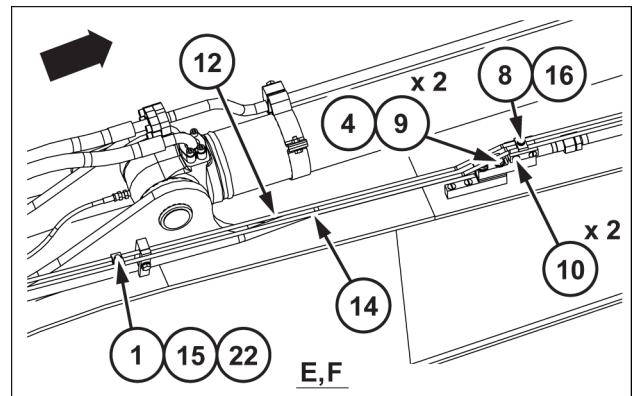

SMIL15CEX8409AB 9

9. Fasten the line assembly (left) (12) and line assembly (right) (14) with two pipe clamps (16), one high-strength bolt (21), one high-strength washer (23), and one nut (7).

- Fasten the pipe clamps (16) at a position **50 mm (1.969 in)** from the seating (stopper, BU, QC) (1).

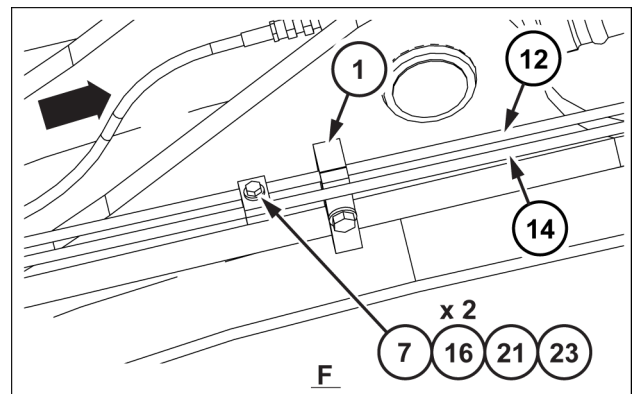

SMIL15CEX8410AB 10

2 - VORMONTAGE

VORBEREITUNG ZUR MONTAGE

Vorbereitung

Ein „*“ in diesem Dokument weist darauf hin, dass das Teil an der vorliegenden Maschine verbaut ist.

Vorzubereitende Elemente:

- Schraubenschlüssel (**13 mm, 19 mm**)
- Ringschlüssel (**13 mm, 19 mm**)
- Sechskantschlüssel (**12 mm**)
- Hebekran
- Schweißgerät
- Lappen

1. Bringen Sie die Haupteinheit in Position.

- Die Haupteinheit auf einem festen und flachen Untergrund abstellen, den Löffelzylinder bis zum Anschlag ausfahren, den Pendelarmzylinder bis zum Anschlag ausfahren, den Ausleger senken und mit dem Pendelarmoberteil den Boden berühren.

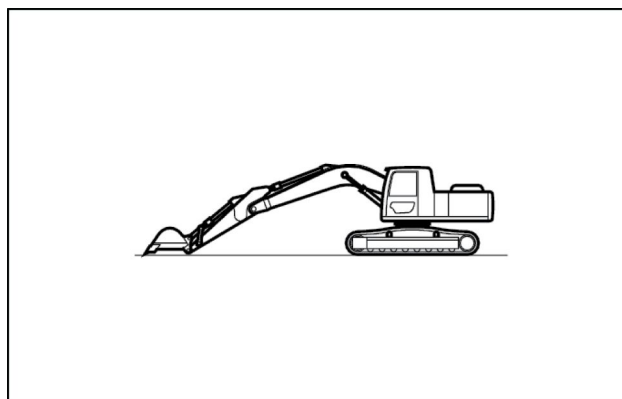

SMIL13II00106AA 1

2. Schalten Sie den Zündschlüssel auf „OFF“ (AUS) (a), vergewissern Sie sich, dass der Motor gestoppt ist, und schalten Sie dann den Zündschlüssel wieder auf „ON“ (EIN). (Den Motor nicht starten.)

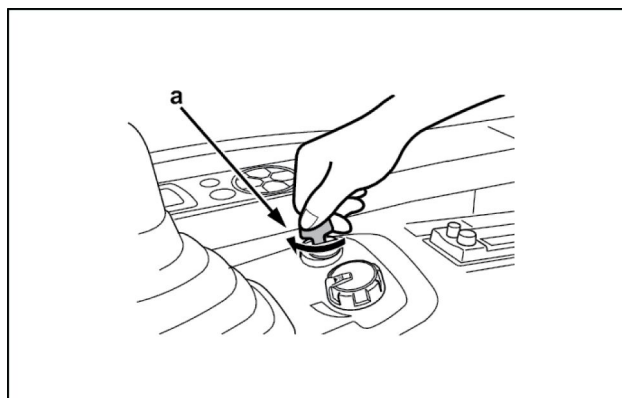

SMIL13II00107AA 2

Sommaire

1 CONTENU DU KIT

Contenu du kit 1-1

2 AVANT-ASSEMBLAGE

PREPARATION POUR L'ASSEMBLAGE

Préparation 2-1

3 ASSEMBLAGE

KIT DE CONDUITE POUR RACCORD RAPIDE (POUR FLECHE STANDARD)

Pose de la flèche standard 3-1

Index

	C	
Contenu du kit		1-1
	P	
Pose de la flèche standard		3-1
Préparation		2-1

3 - MONTAGGIO

KIT TUBAZIONE ATTACCO RAPIDO (PER AVAMBRACCIO STANDARD)

Montaggio avambraccio standard

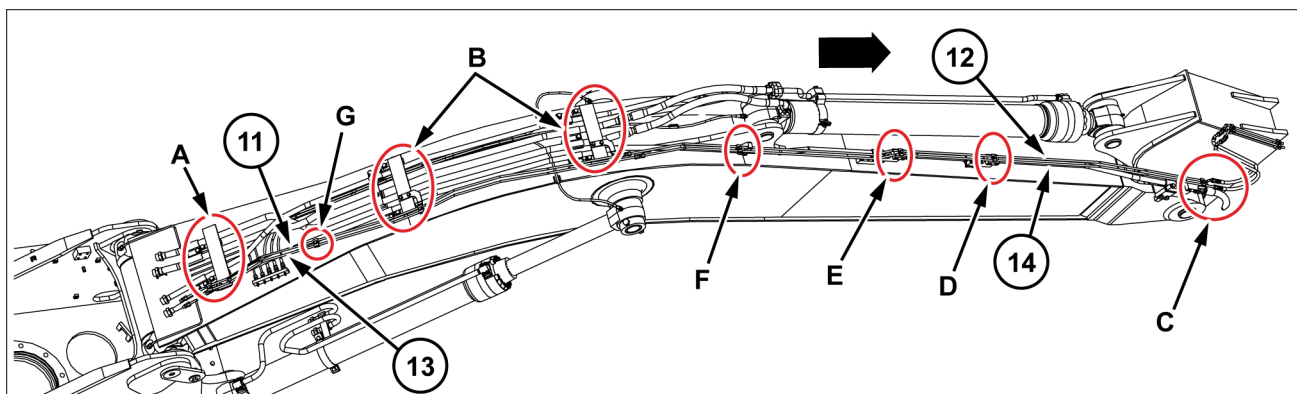

SMIL15CEXY586EB 1

Applicare **LOCTITE® (20)** alla sezione filettata dei bulloni tipo Sems e dei bullone ad alta resistenza.

1. Utilizzare una gru o un attrezzatura simile, per posizionare il complessivo tubazione (lato sinistro) (11) e il complessivo tubazione (lato destro) (13) sul braccio.

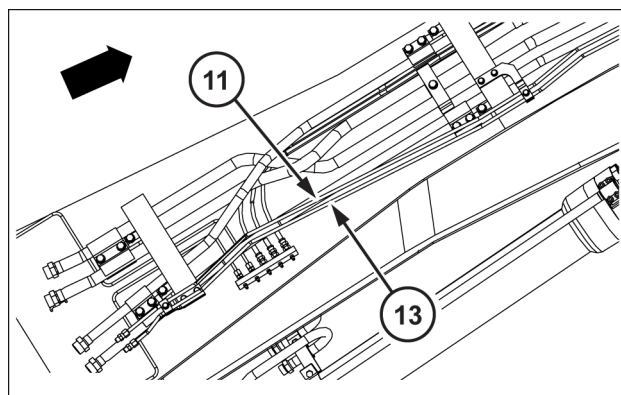

SMIL15CEX8403AB 2

2. Montare la sede (base braccio QC) (5) con 2 bulloni tipo Sems (9).
Montare la sede (base braccio QC) (6) con 2 bulloni tipo Sems (8).
Montare i due raccordi corpo (19) sui lati posteriori del complessivo tubazione (lato sinistro) (11) e del complessivo tubazione (lato destro) (13).
Fissare il complessivo tubazione (lato sinistro) (11) e il complessivo tubazione (lato destro) (13) con la fascetta per tubi (16), il bullone ad alta resistenza (21) e la rondella ad alta resistenza (23).

- Fissare la fascetta per tubi (16) su un punto a **165 mm (6.496 in)** dal lato posteriore del raccordo corpo sinistro (19) e **159 mm (6.260 in)** dal lato posteriore del raccordo corpo destro (19).

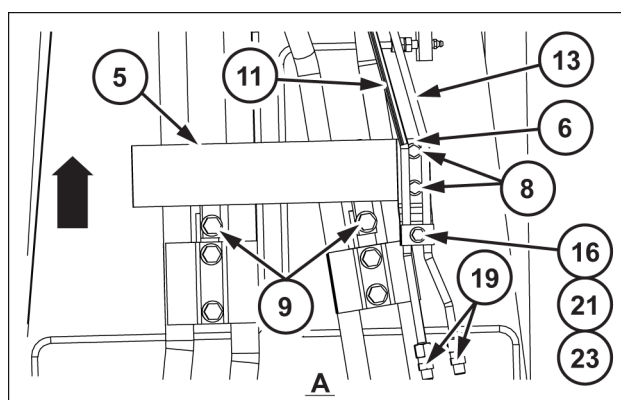

SMIL15CEX8404AB 3

1 - CONTENIDO DEL KIT

Contenido del kit

NOTA: consulte el manual de piezas para los pedidos.

Pluma estándar (consulte 3-1)

Elemento	Descripción	Cantidad	Referencia
1	Asiento (unión BU, acoplador rápido QC)	1	KBV40900
2	Asiento (centro de la pluma - acoplador rápido)	2	KHV13670
3	Asiento (centro de la pluma - acoplador rápido)	2	KBV38610
4	Asiento (tope de la pluma - acoplador rápido)	2	KBV38650
5	Asiento (base de la pluma - acoplador rápido)	1	KBV38570
6	Asiento (base de la pluma - acoplador rápido)	1	KBV39430
7	Tuerca M8	2	162R008SR
8	Perno SEMS M8x25	9	105R008Y025R
9	Perno SEMS M12x60	12	105R012Y060R
10	Tapa de tornillo	6	KHV12270
11	Conjunto de conductos (izquierdo)	1	KBV38470
12	Conjunto de conductos (izquierdo)	1	KBV40820
13	Conjunto de conductos (derecho)	1	KBV38480
14	Conjunto de conductos (derecho)	1	KBV40830
15	Abrazadera	1	KBV40910
16	Abrazadera	10	KHV13660
17	Abrazadera	1	KHV11640
18	Unión	2	KMJ0602
19	Unión	4	KMJ0708
20	LOCTITE®	1	KRC5007
21	Perno de alta resistencia M8x35	5	102R008Y035R
22	Perno de alta resistencia M12x30	1	102R012Y030R
23	Arandela de alta resistencia M8	5	KAJ1500
24	Asiento (tope de la pluma - acoplador rápido)	1	KBV40860

CLICK HERE TO **DOWNLOAD** THE COMPLETE MANUAL

- Thank you very much for reading the preview of the manual.
- You can download the complete manual from: www.heydownloads.com by clicking the link below



- Please note: If there is no response to CLICKING the link, please download this PDF first and then click on it.

CLICK HERE TO **DOWNLOAD** THE COMPLETE MANUAL