



## **INSTALLATION INSTRUCTIONS**

**KG0TP707-00  
CAMERA (RIGHT-HAND SIDE) KIT**

**APPROXIMATE INSTALLATION TIME: 1.5 hours**

CLICK HERE TO **DOWNLOAD** THE COMPLETE MANUAL

- Thank you very much for reading the preview of the manual.
- You can download the complete manual from: [www.heydownloads.com](http://www.heydownloads.com) by clicking the link below



- Please note: If there is no response to CLICKING the link, please download this PDF first and then click on it.

CLICK HERE TO **DOWNLOAD** THE COMPLETE MANUAL

2. Route the CCD camera wire harness (1) as shown in the diagram, bringing it out on the inside of the harness hole on the frame (\*4).

Fasten the CCD camera wire harness (1) with five wire bands (2).

- Fasten one of the wire bands (2) at the 2nd white marking (\*11) on the CCD camera wire harness (1).
- Fasten the CCD camera wire harness (1) together with the frame main harness (\*3).

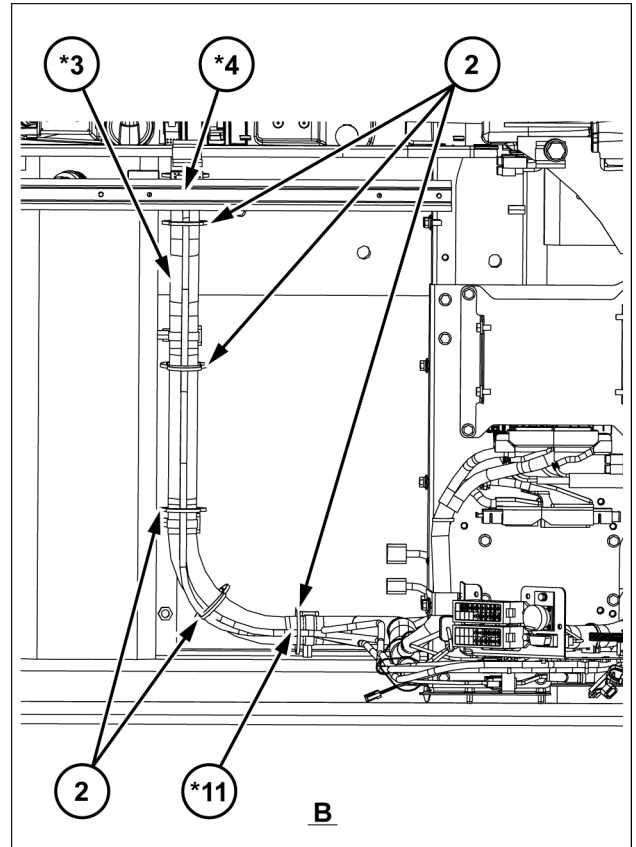

SML15CEXY628BB 3

3. Route the CCD camera wire harness (1) to point D behind the main unit.

- Do not fasten the harness at this point.

4. Route the CCD camera wire harness (1) as shown in the diagram and fasten with nine wire bands (2) and one mount clamp (26).

- Fasten one of the wire bands (2) at the white marking (\*7) on the CCD camera wire harness (1).
- Fasten the CCD camera wire harness (1) together with the frame main harness (\*3).

Connect the CCD camera wire harness (1) and wire harness (22) with the connector (\*15), and then fasten with the clip (25) and bolt (21).

Fasten the wire harness (22) with two wire bands (2) and one mount clamp (26).

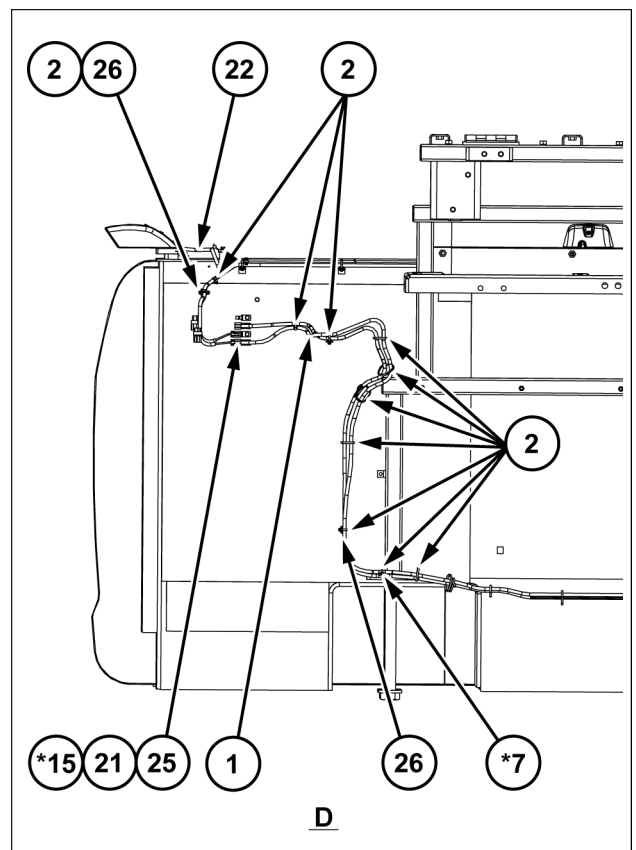

SML15CEXY629BB 4

# 1 - SATZINHALT

## Satzinhalt

*HINWEIS: Bitte ziehen Sie für die Bestellung von Teilen das Teilehandbuch heran.*

### Seitenkamera (siehe 3-1)

Gegenstand	Beschreibung	Anzahl	Teilereferenz
1	Kabelbaum (CCD-Kameragelenk)	1	KHR41630
2	Kabelbinder ( L = 250 )	-	KHH0142
6	CCD-Kamera	1	KHR23830
7	Kameraträger	1	KHR28630
8	Hochfeste Schraube M6 x 16	5	KHN2132
9	Schraube mit unverlierbarer Unterlegscheibe M8 x 20	2	105R008Y020R
10	Klemme mit Band M8	1	KHR2583
12	Kameraabdeckung	1	KHR28640
13	Befestigungsklemme	1	KHR1445
14	Warnaufkleber	1	KHP18460
21	Schraube M6 x 16	1	KHR1253
22	Kabelbaum	1	KHR45200
23	Kamerahalterung (Rückfahrkamera)	1	KSR14130
24	Innensechskantschraube M8 x 20	2	108R008Y020R
25	Klammer	1	KHR1957
26	Befestigungsschelle	2	KHR10220

# Index

---

	<b>E</b>	
Einbau der Seitenkamera . . . . .		3-1
	<b>S</b>	
Satzinhalt . . . . .		1-1
	<b>V</b>	
Vorbereitung . . . . .		2-1

### 3 - ASSEMBLAGE

#### ECLAIRAGE DE CAMERA (COTE DROIT)

#### Pose de caméra latérale

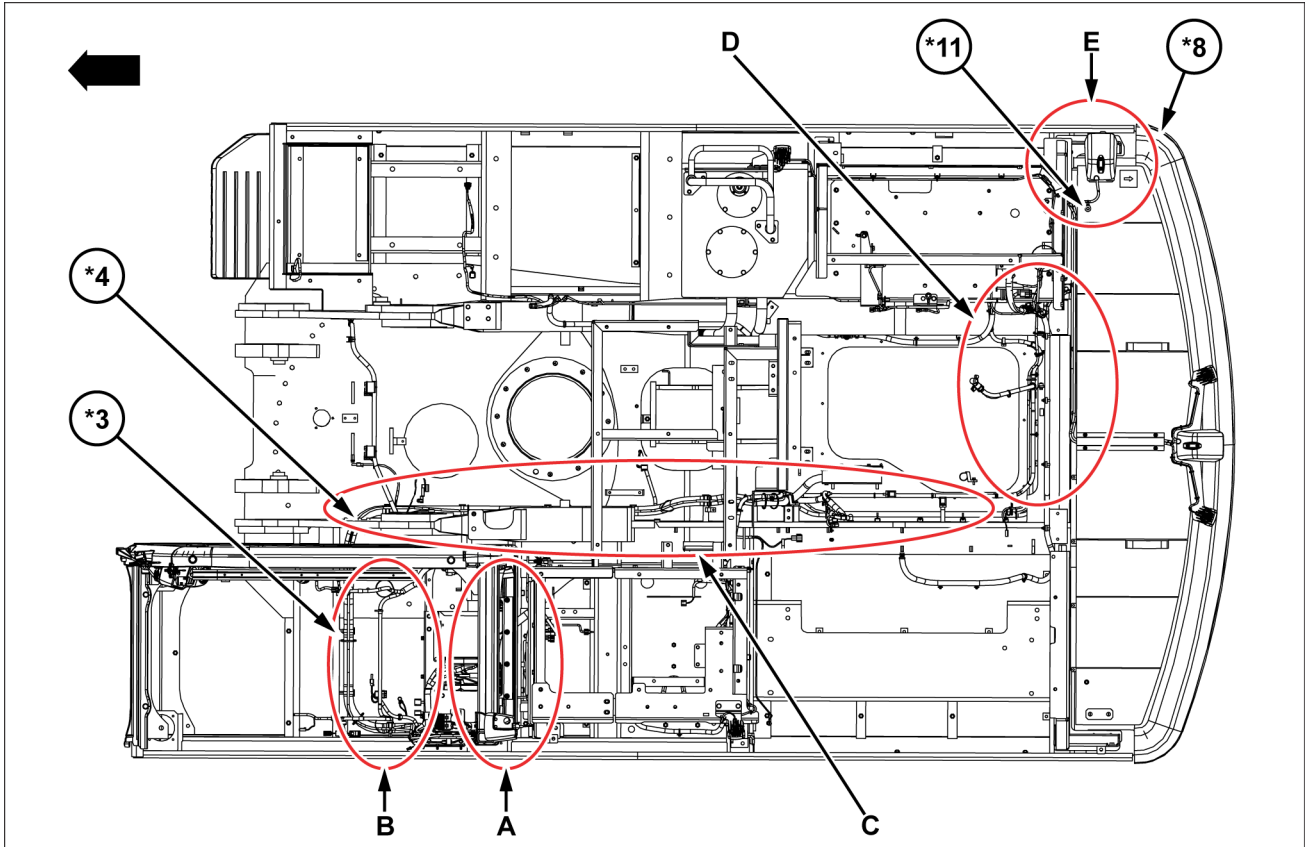

SMIL15CEXY626FB 1

# Contenuto

---

<b>1 CONTENUTO DEL KIT</b>	
Contenuto del kit .....	1-1
<b>2 PRE-ASSEMBLAGGIO</b>	
<b>OPERAZIONI PRELIMINARI PER IL MONTAGGIO</b>	
Preparazione .....	2-1
<b>3 MONTAGGIO</b>	
<b>LUCE TELECAMERA (LATO DESTRO)</b>	
Montaggio della telecamera laterale .....	3-1

- Montare la telecamera CCD (**6**) sulla staffa della telecamera (**7**) con 2 bulloni ad alta resistenza (**8**).

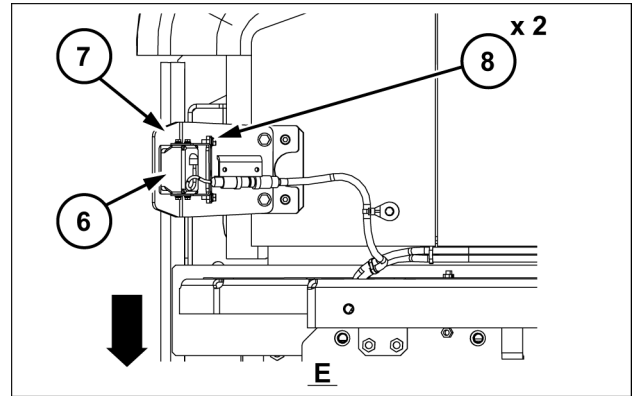

- Collegare il connettore del cablaggio (**22**) e il connettore (\***9**) della telecamera CCD (**6**), quindi fissare con la fascetta a nastro (**13**) e il bullone ad alta resistenza (**8**).  
Montare il coperchio della telecamera (**12**) con 2 bulloni ad alta resistenza (**8**).  
A. Lato sinistro

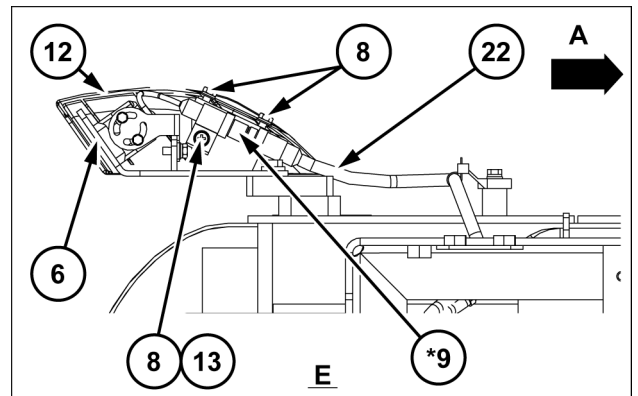

### Applicazione dell'etichetta

- Con un panno, rimuovere eventuale sporcizia presente nel punto in cui verrà incollata l'etichetta.
- Applicare l'etichetta di avvertenza (**14**).
  - Applicare l'etichetta di avvertenza (**14**) in modo che la freccia sia rivolta verso il lato superiore dell'etichetta.

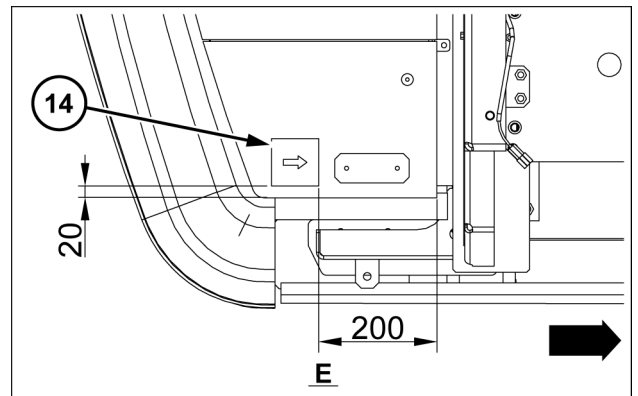

## 2 - PREENSAMBLADO

### PREPARACIÓN PARA MONTAJE

#### Preparación

En este documento, el símbolo “\*” indica que la pieza está montada en la máquina actual.

Elementos necesarios

- Llaves ( **10 mm**, **13 mm** )
- Cizallas de cables
- Crimpadora
- Marcador borrable
- Cuchilla
- Trapo

1. Coloque la máquina.

- Ponga la máquina en una superficie sólida y nivelada, extienda totalmente el cilindro de la cuchara y el cilindro del brazo, y baje la pluma hasta que la parte superior del brazo toque en el suelo.

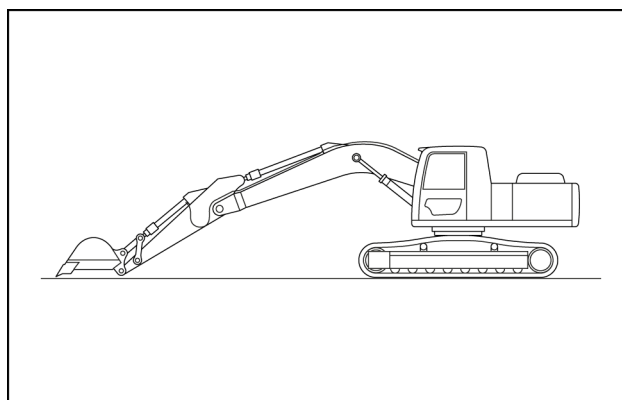

SMIL14II01743AA 1

2. Ponga la llave de contacto en OFF (Apagado) y compruebe que el motor esté parado.  
Desconecte el terminal negativo (-) de la batería.

 **AVISO:** Asegúrese de apagar la corriente (ponga el interruptor del motor de arranque en posición de apagado) antes de manipular la batería.

\* Después de realizar el trabajo, vuelva a colocar el borne (-) de la batería a su posición original.

CLICK HERE TO **DOWNLOAD** THE COMPLETE MANUAL

- Thank you very much for reading the preview of the manual.
- You can download the complete manual from: [www.heydownloads.com](http://www.heydownloads.com) by clicking the link below



- Please note: If there is no response to CLICKING the link, please download this PDF first and then click on it.

CLICK HERE TO **DOWNLOAD** THE COMPLETE MANUAL