



INSTALLATION INSTRUCTIONS

KG0SP787-00
LOW FLOW HYDRAULIC KIT

APPROXIMATE INSTALLATION TIME: 9 hours

CLICK HERE TO **DOWNLOAD** THE COMPLETE MANUAL

- Thank you very much for reading the preview of the manual.
- You can download the complete manual from: www.heydownloads.com by clicking the link below



- Please note: If there is no response to CLICKING the link, please download this PDF first and then click on it.

CLICK HERE TO **DOWNLOAD** THE COMPLETE MANUAL

Control valve - Install

CX350C WE, CX370C

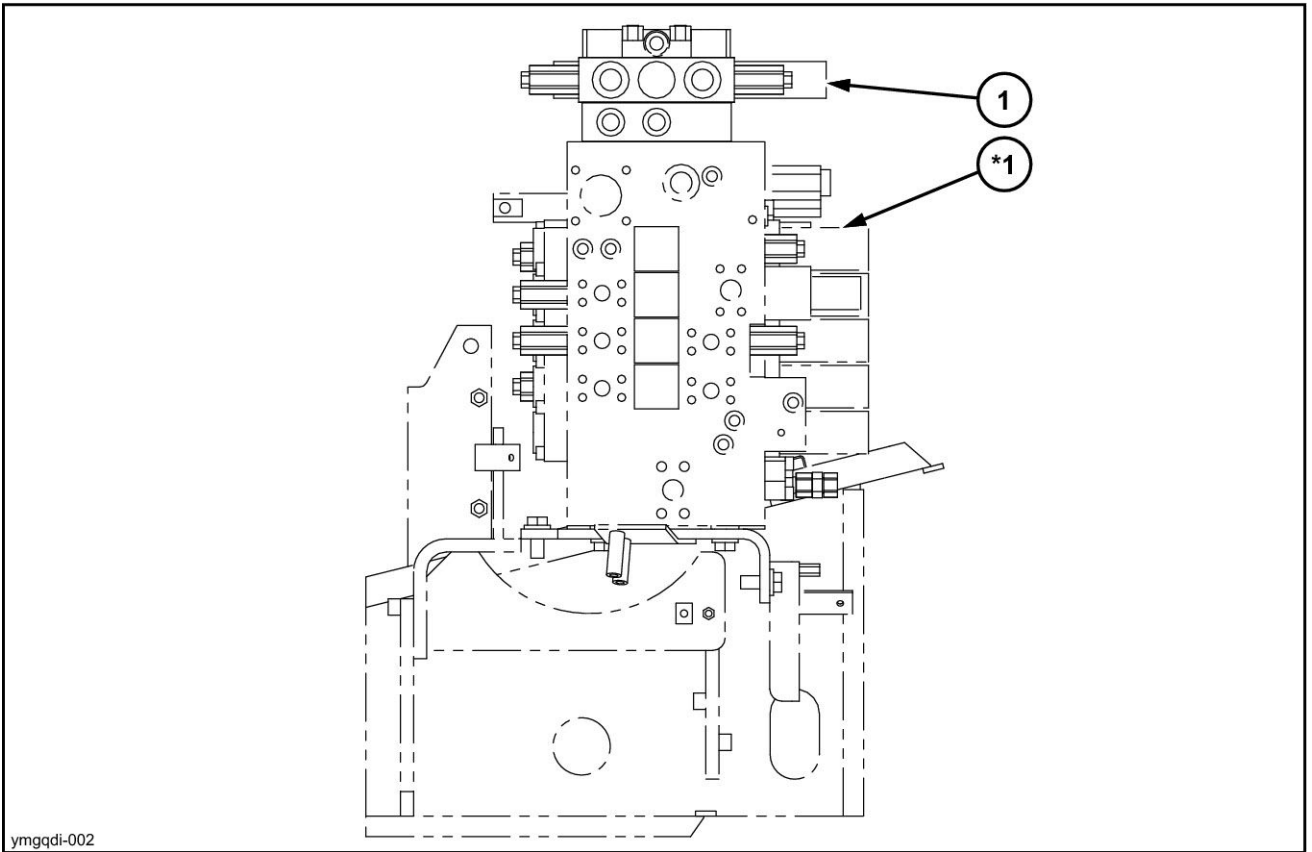

ymgqdi-002

YMGQDI-002 1

- Install the add-on 2nd option control valve (1) on the control valve (*1) with the 4 nuts (1a) and 4 tie rods (1b)

 - Tightening torque:
 $122 \pm 6 \text{ N}\cdot\text{m}$ ($1079.8 \pm 53.1 \text{ lb in}$).

Replace the O-ring (1c) and tie rods (1b) with new ones.

The nuts (1a), tie rods (1b), and O-ring (1c) are accessories for the add-on 2nd option control valve.

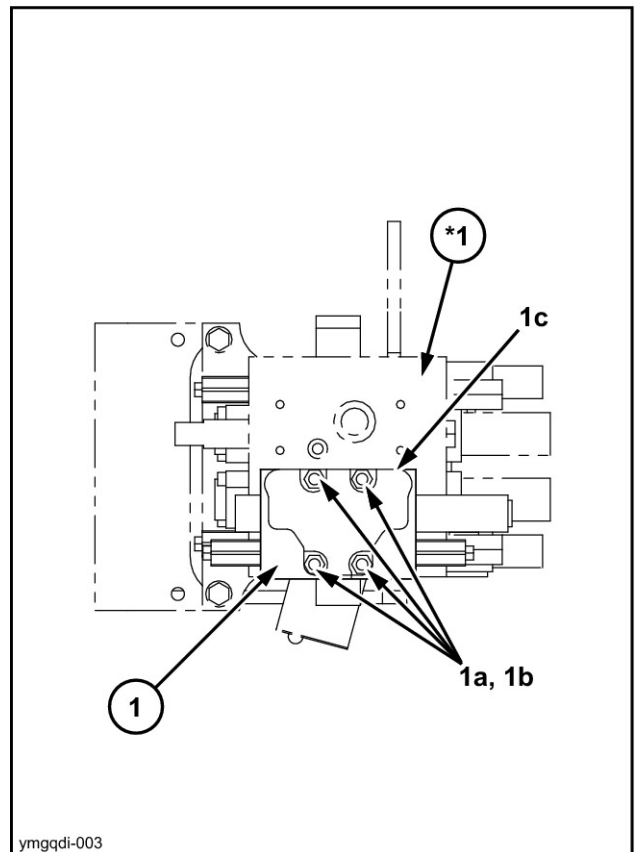

ymgqdi-003

YMGQDI-003 2

3. Install the hose adapter (**18**) on the control valve (***2**) BR2 port.

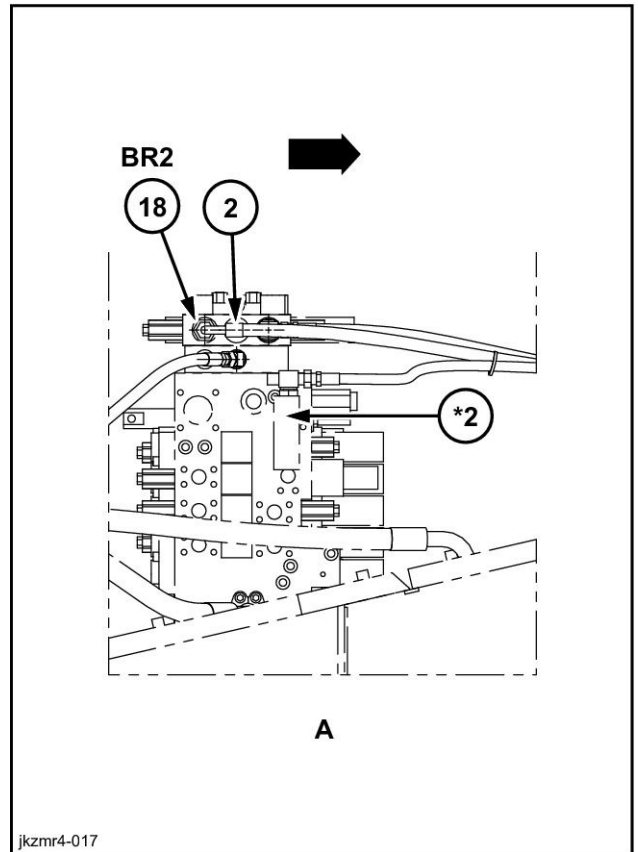

JKZMR4-017 4

4. Connect the control valve (***2**) BR2 port and the line assembly (right) (***4**) with the hydraulic hose (**2**).

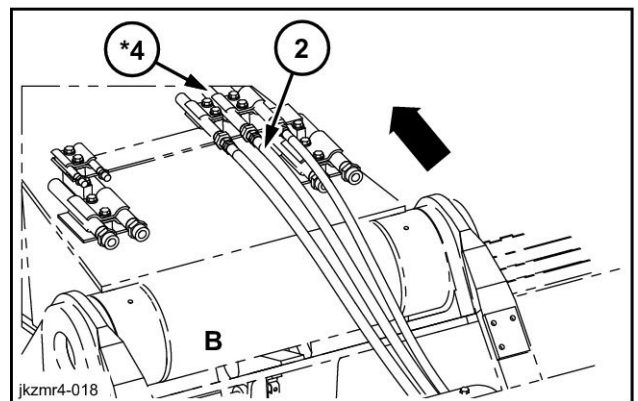

JKZMR4-018 5

- Install the hose adapter (7) at the manifold (*2) T5 port.
Connect the option remote control valve (*1) T port and manifold (*2) T5 port with the assembly hose (3)/(T6).

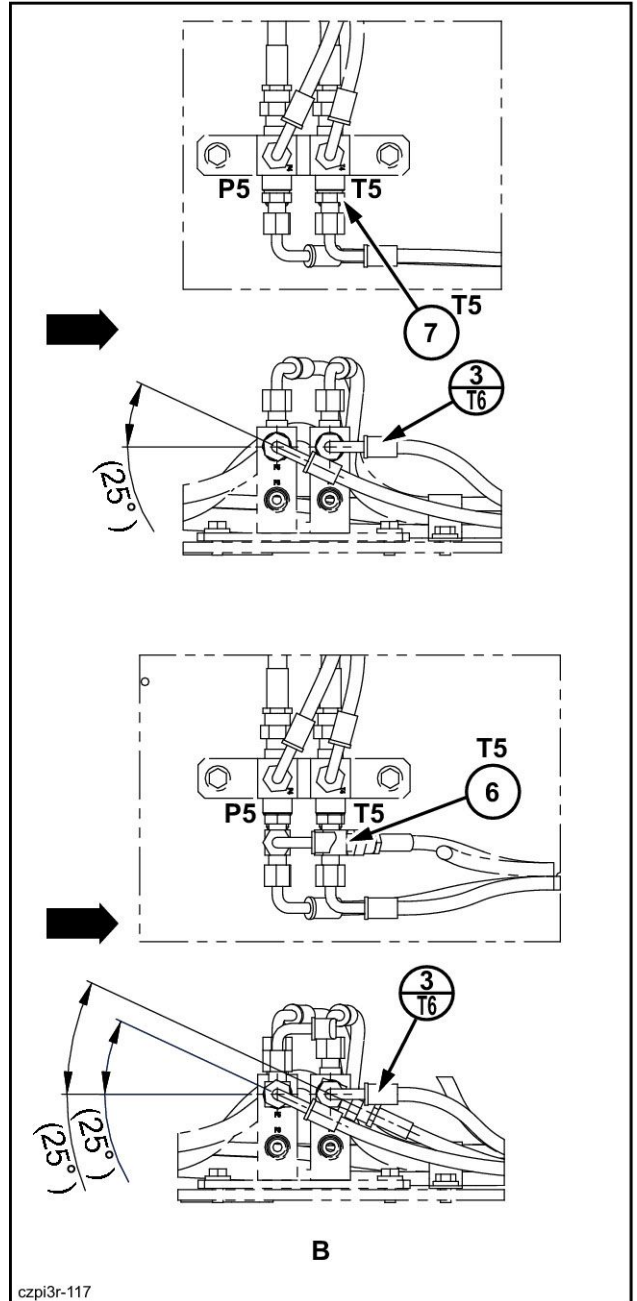

CZPI3R-117 5

- Install the nipple (12) on the option remote control valve (*1) P port.

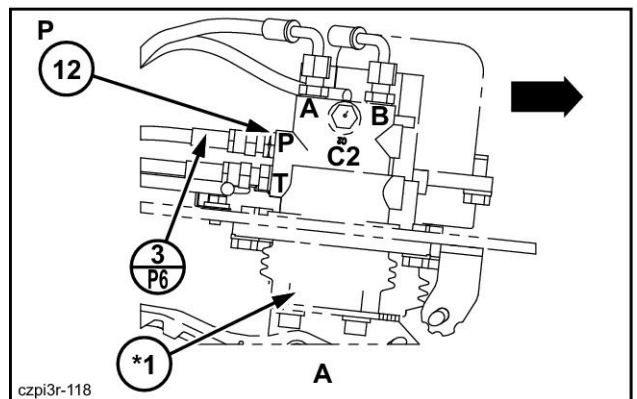

CZPI3R-118 6



INSTRUCTIONS D'INSTALLATION

KG0SP787-00
KIT DE CIRCUIT HYDRAULIQUE BAS DEBIT

TEMPS D'INSTALLATION APPROXIMATIF : 9 heures

Distributeur - Pose

CX350C WE, CX370C

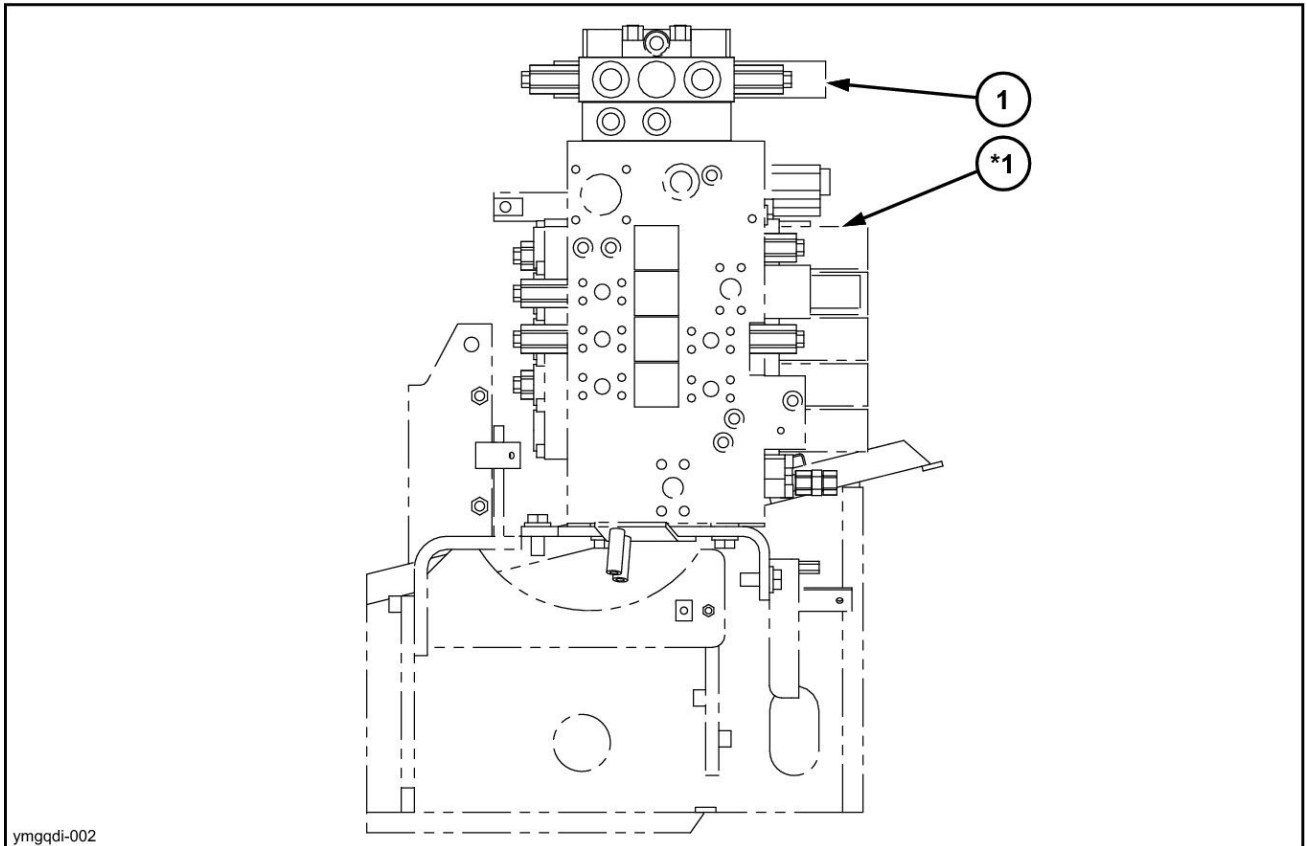

YMGQDI-002 1

1. Mettre en place le distributeur de 2ème option supplémentaire (**1**) sur le distributeur (***1**) à l'aide des 4 écrous (**1a**) et des 4 tirants (**1b**)
 - Couple de serrage : **122 ± 6 N·m (1079.8 ± 53.1 lb in)**.
 Remplacer le joint torique (**1c**) et les tirants (**1b**) par des pièces neuves.
 Les écrous (**1a**), tirants (**1b**) et joint torique (**1c**) sont des accessoires du distributeur de 2ème option supplémentaire.

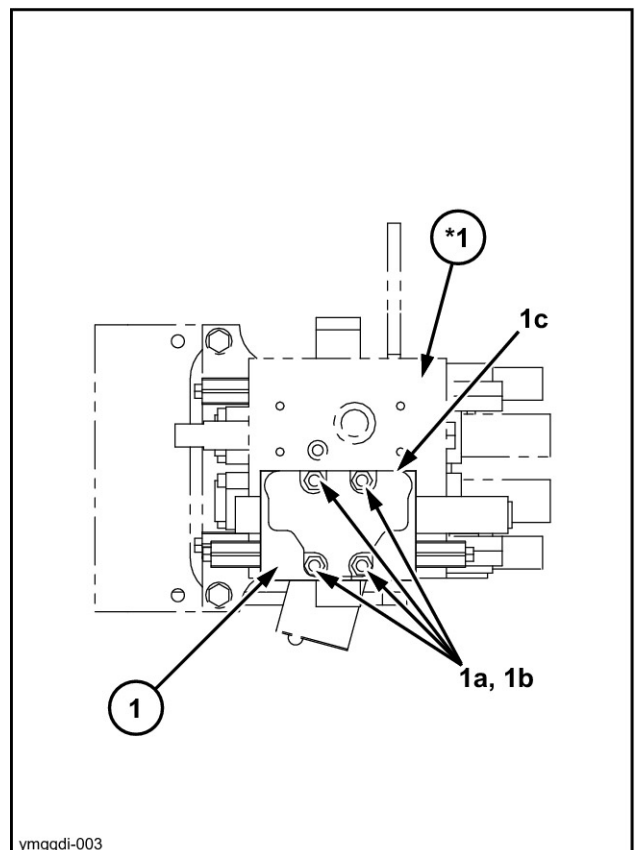

YMGQDI-003 2

3. Mettre en place l'adaptateur de flexible (18) sur l'orifice BR2 du distributeur (*2).

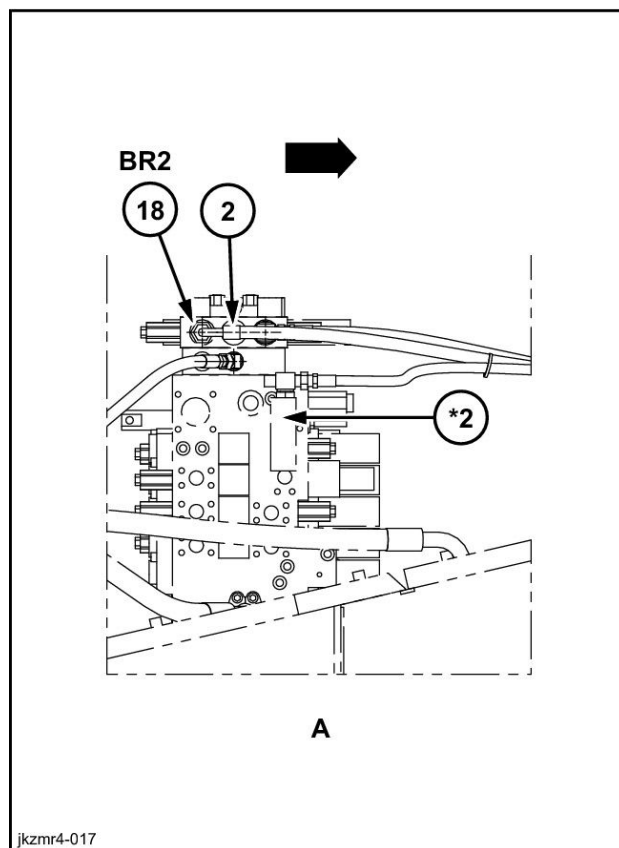

JKZMR4-017 4

4. Raccorder l'orifice BR2 du distributeur (*2) et l'ensemble conduite (droite) (*4) à l'aide du flexible hydraulique (2).

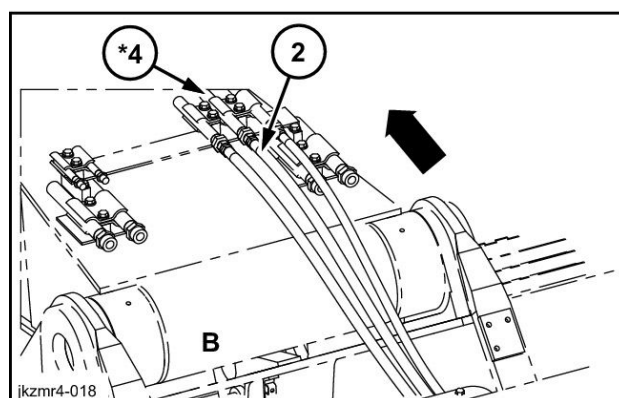

JKZMR4-018 5

2. Mettre en place l'adaptateur de flexible (7) sur l'orifice T5 du collecteur (*2).
Raccorder l'orifice T du distributeur à distance d'option (*1) et l'orifice T5 du collecteur (*2) à l'aide du flexible d'assemblage (3)/ (T6).

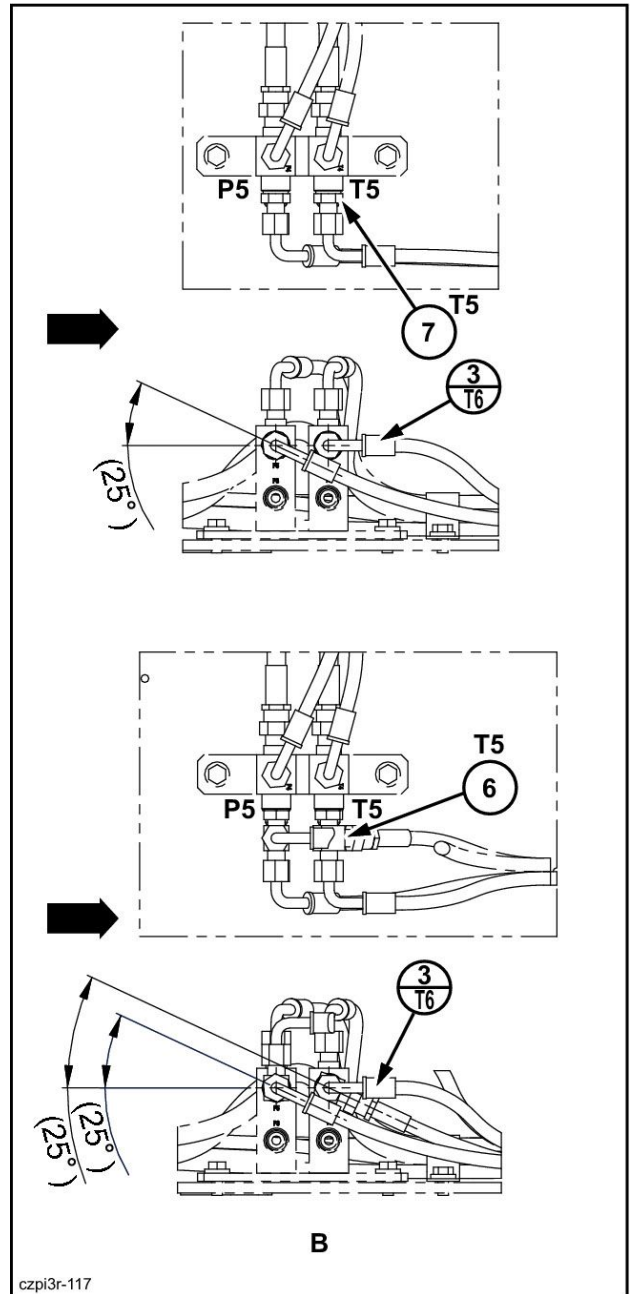

CZPI3R-117 5

3. Mettre en place l'embout (12) sur l'orifice P du distributeur à distance d'option (*1).

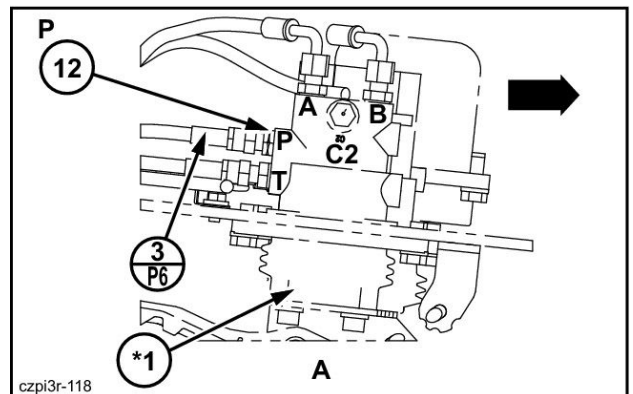

CZPI3R-118 6



INSTALLATIONSANWEISUNG

KG0SP787-00
HYDRAULIKSATZ FÜR KLEINE DURCHFLUSSMENGEN

UNGEFÄHRE EINBAUZEIT: 9 Stunden

Steuerventil - Montieren

CX350C WE, CX370C

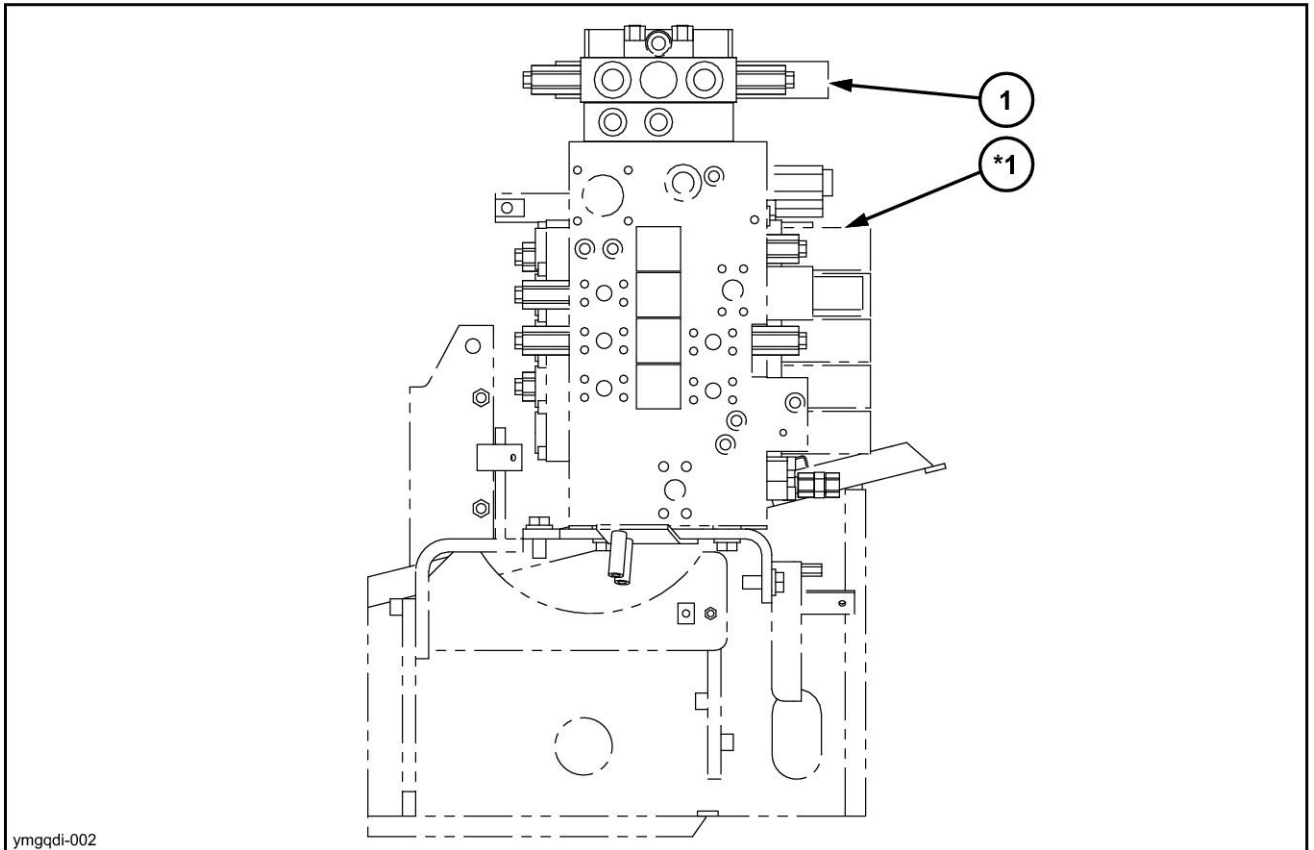

ymgqdi-002

YMGQDI-002 1

- Das zusätzliche 2. Zusatzausstattungs-Steuerventil (**1**) am Steuerventil (***1**) mit den 4 Muttern (**1a**) und 4 Befestigungsstangen (**1b**) anbringen.
 - Anzugsmoment:
 $122 \pm 6 \text{ N}\cdot\text{m}$ ($1079.8 \pm 53.1 \text{ lb in}$).
 - Den O-Ring (**1c**) und die Befestigungsstangen (**1b**) durch neue ersetzen.
 - Die Muttern (**1a**), Befestigungsstangen (**1b**) und O-Ring (**1c**) sind Zubehörteile für das zusätzliche 2. Zusatzausstattungs-Steuerventil.

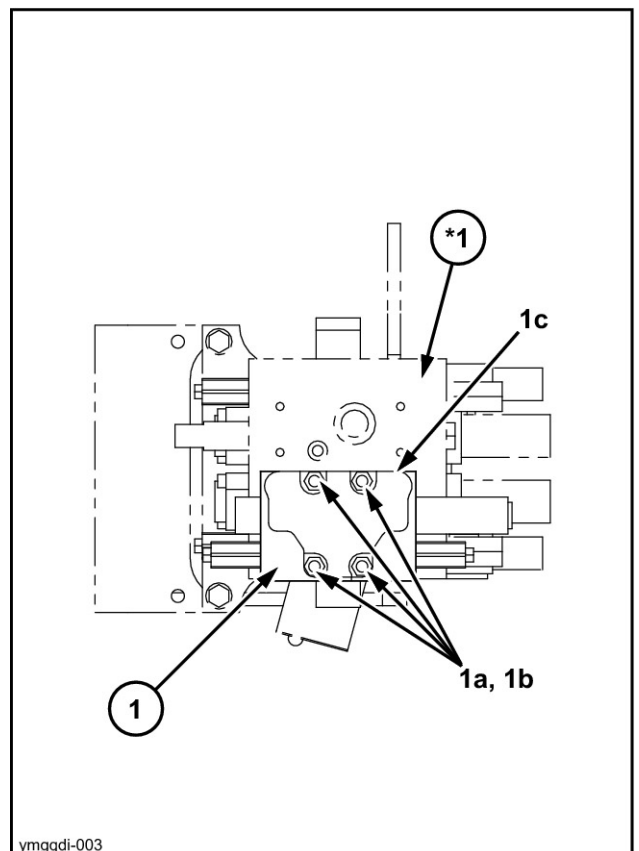

ymgqdi-003

YMGQDI-003 2

CLICK HERE TO **DOWNLOAD** THE COMPLETE MANUAL

- Thank you very much for reading the preview of the manual.
- You can download the complete manual from: www.heydownloads.com by clicking the link below



- Please note: If there is no response to CLICKING the link, please download this PDF first and then click on it.

CLICK HERE TO **DOWNLOAD** THE COMPLETE MANUAL

3. Den Schlauchadapter (**18**) an Anschluss BR2 des Steuerventils (***2**) anbringen.

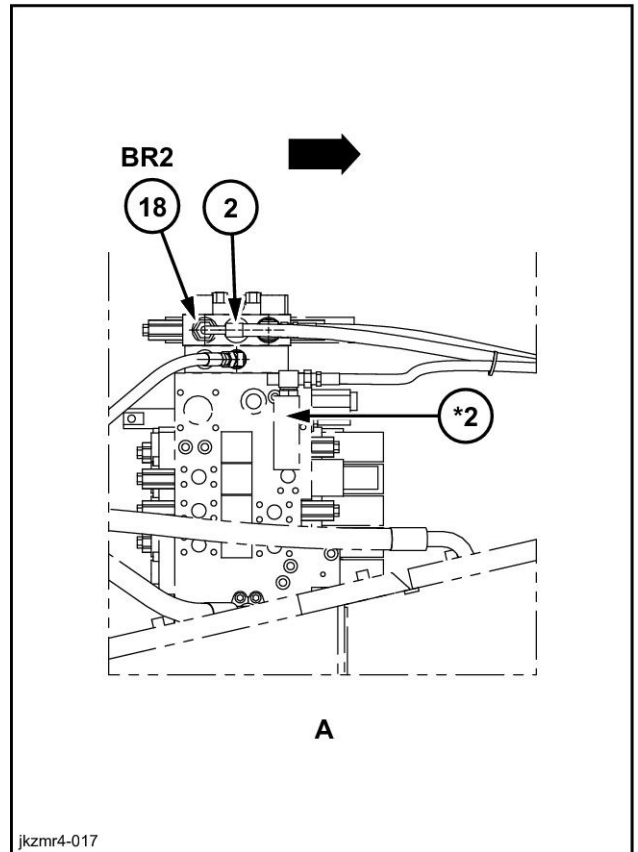

JKZMR4-017 4

4. Den Anschluss BR2 des Steuerventils (***2**) und die Leitungsbaugruppe (rechts) (***4**) mit dem Hydraulikschlauch (**2**) verbinden.

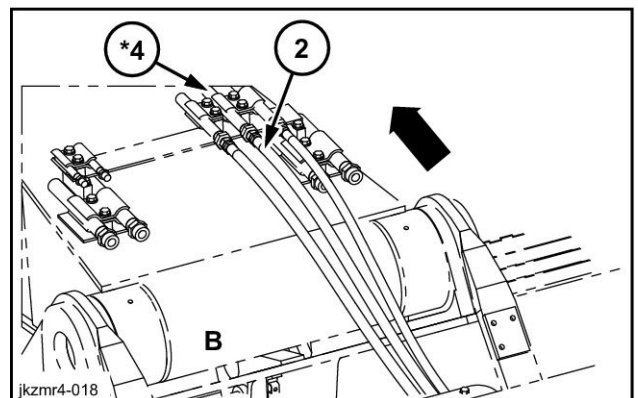

JKZMR4-018 5

2. Den Schlauchadapter (7) an Anschluss T5 des Sammlers (*2) anbringen.
Den Anschluss T des Zusatzausstattungs-Fernsteuerventils (*1) und den Anschluss T5 des Sammlers (*2) mit dem Verbindungsschlauch (3)/ (T6) verbinden.

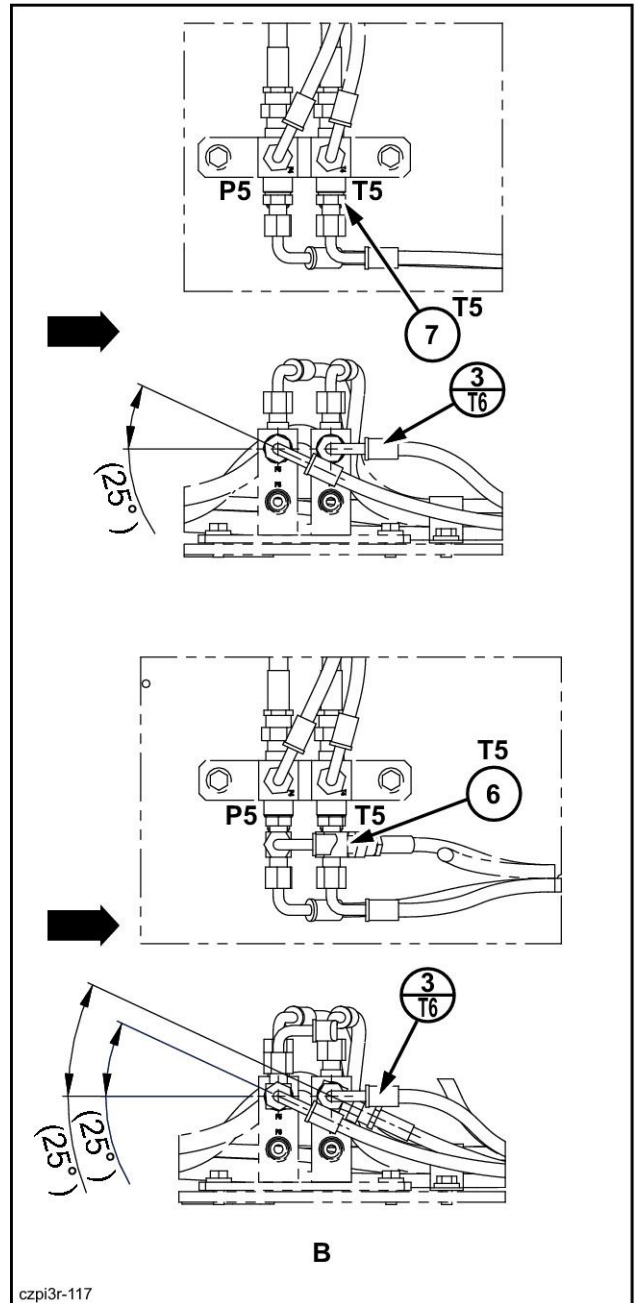

CZPI3R-117 5

3. Den Nippel (12) an Anschluss P des Zusatzausstattungs-Fernsteuerventils (*1) anbringen.

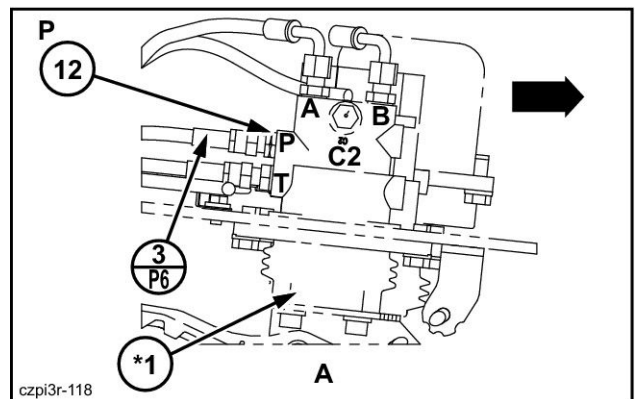

CZPI3R-118 6



INSTRUCCIONES DE INSTALACIÓN

KG0SP787-00
KIT HIDRÁULICO DE BAJO FLUJO

TIEMPO DE INSTALACIÓN APROXIMADO: 9 horas

Válvula de control - Instalar

CX350C WE, CX370C

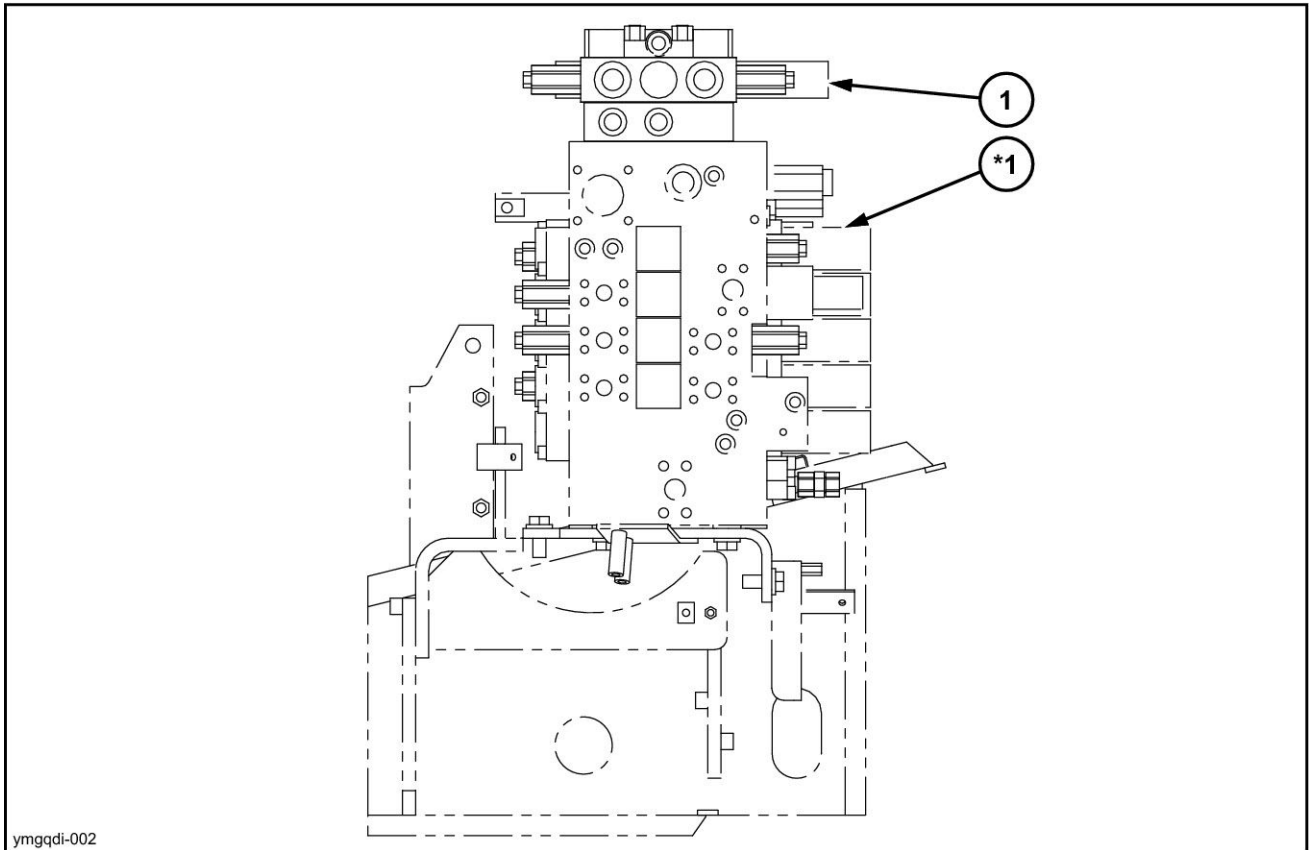

ymgqdi-002

YMGQDI-002 1

1. Instalar la válvula de control de 2a opción auxiliar (1) en la válvula de control (*1) con las 4 tuercas (1a) y los 4 tirantes (1b)
 - Par de apriete:
 $122 \pm 6 \text{ N}\cdot\text{m}$ ($1079.8 \pm 53.1 \text{ lb in}$).
 Sustituir la junta tórica (1c) y los tirantes (1b) por nuevos.
 Las tuercas (1a), los tirantes (1b) y la junta tórica (1c) son accesorios para la válvula de control de 2a opción auxiliar.

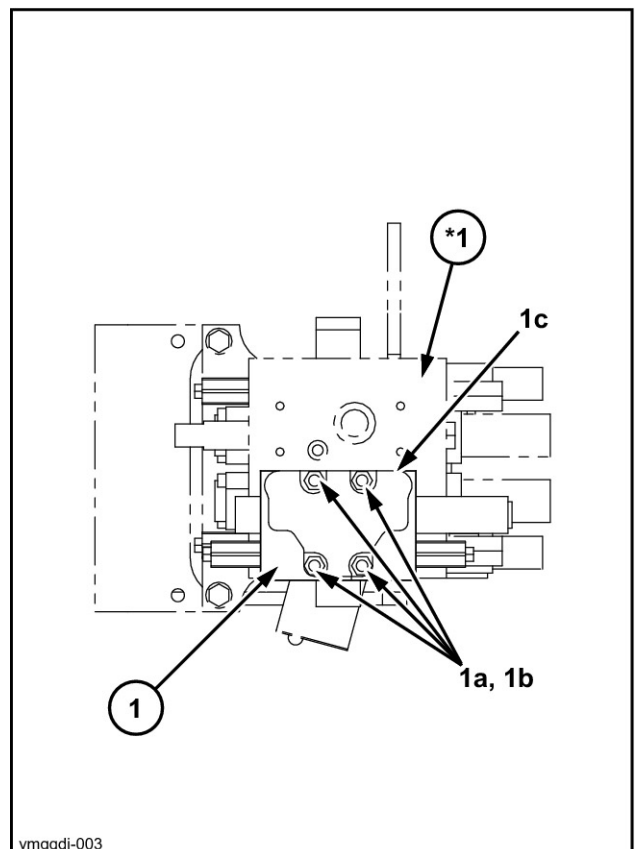

ymgqdi-003

YMGQDI-003 2

3. Instalar el adaptador de tubo flexible (18) en el orificio BR2 de la válvula de control (*2).

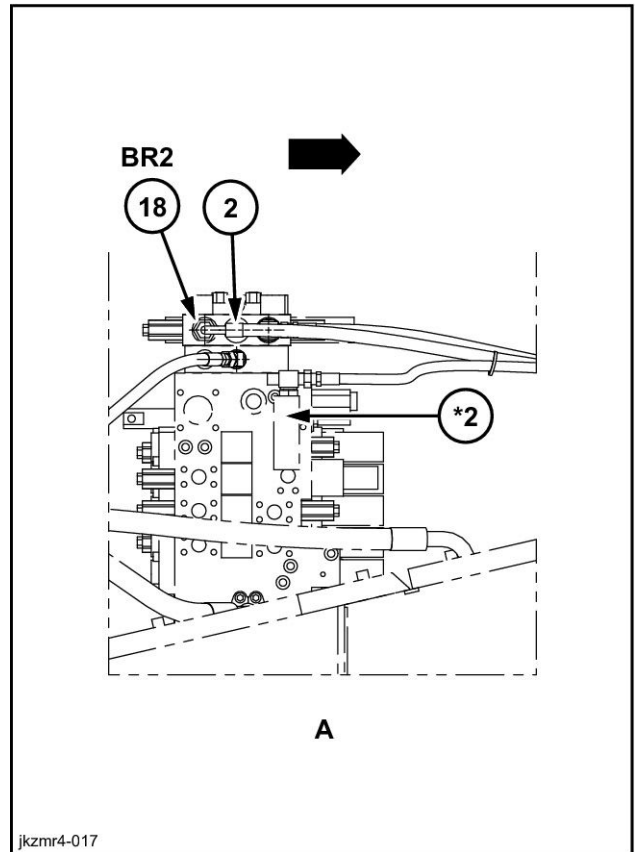

JKZMR4-017 4

4. Conectar el orificio BR2 de la válvula de control (*2) y el conjunto conducto (derecha) (*4) con el tubo flexible hidráulico (2).

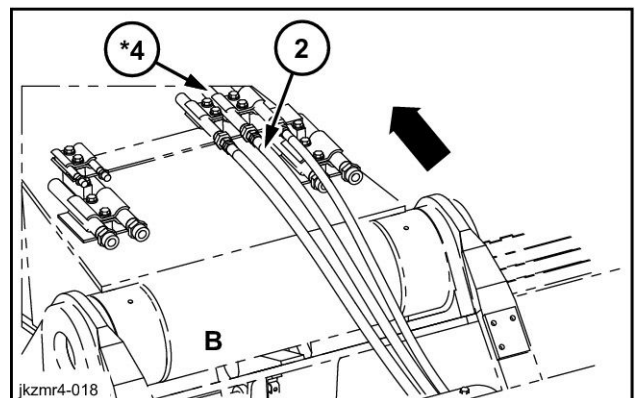

JKZMR4-018 5

2. Instalar el adaptador de tubo flexible (7) en el orificio T5 del colector (*2). Conectar el orificio T de la válvula de control remoto opcional (*1) y el orificio T5 del colector (*2) con el tubo flexible (3) / (T6).

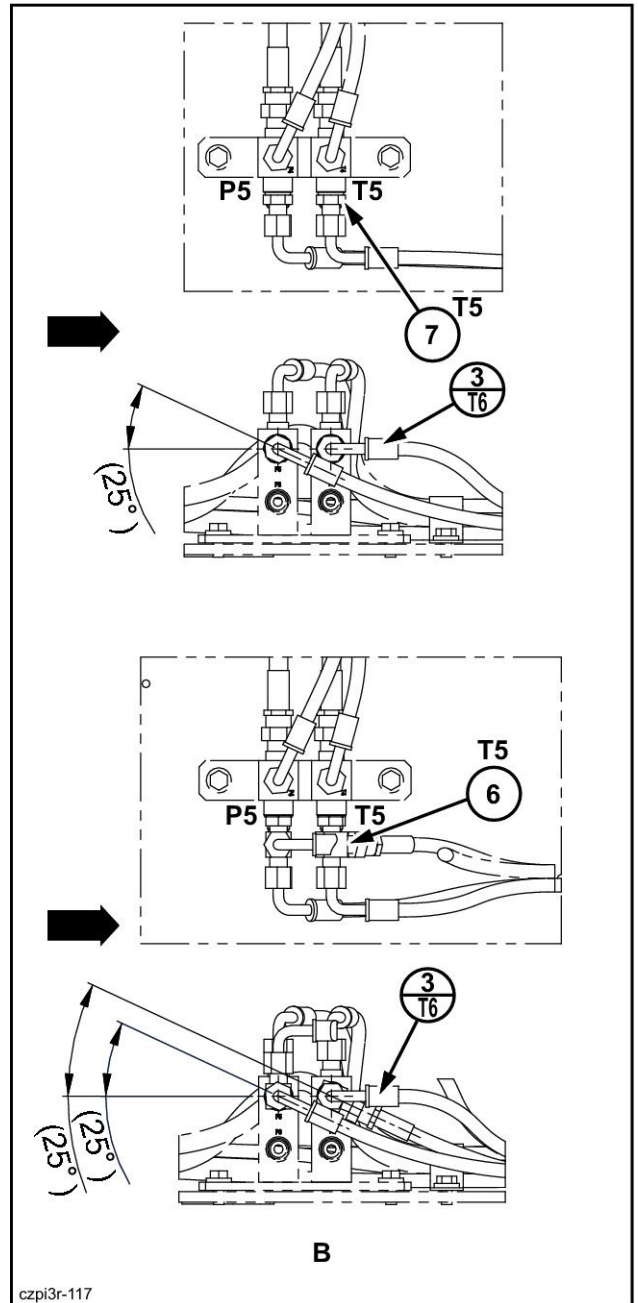

CZPI3R-117 5

3. Instalar la boquilla (12) en orificio P de la válvula de control remoto opcional (*1).

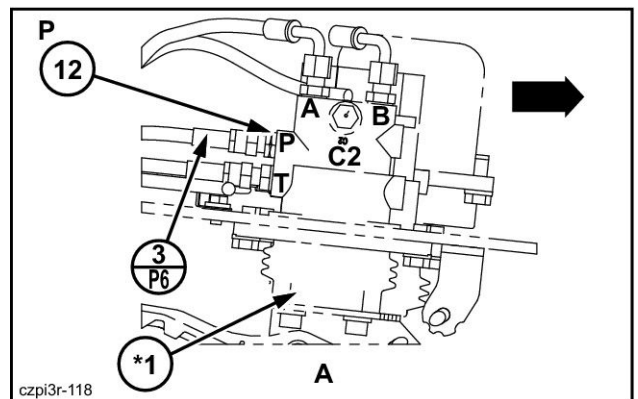

CZPI3R-118 6



ISTRUZIONI DI MONTAGGIO

**KG0SP787-00
KIT IDRAULICO A BASSA PORTATA.**

TEMPO DI MONTAGGIO APPROSSIMATIVO: 9 ore

Valvola di comando - Montaggio

CX350C WE, CX370C

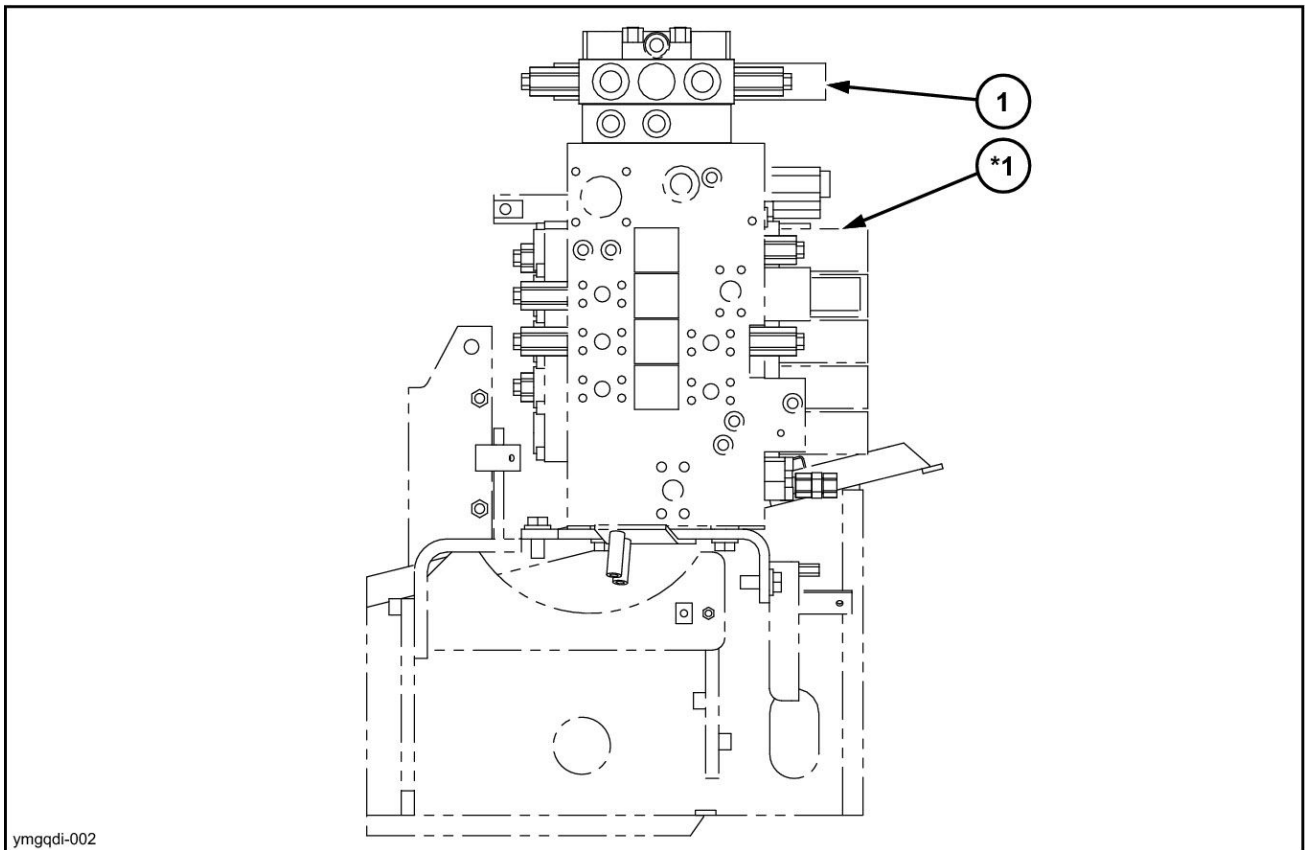

YMGQDI-002 1

1. Montare il distributore aggiuntivo della seconda opzione **(1)** sul distributore **(*1)** con i 4 dadi **(1a)** e 4 tiranti **(1b)**
 - Coppia di serraggio:
122 ± 6 N·m (1079.8 ± 53.1 lb in).

Sostituire l'O-ring **(1c)** e i tiranti **(1b)** con dei nuovi. I dadi **(1a)**, i tiranti **(1b)** e gli O-ring **(1c)** sono accessori per il distributore aggiuntivo della seconda opzione.

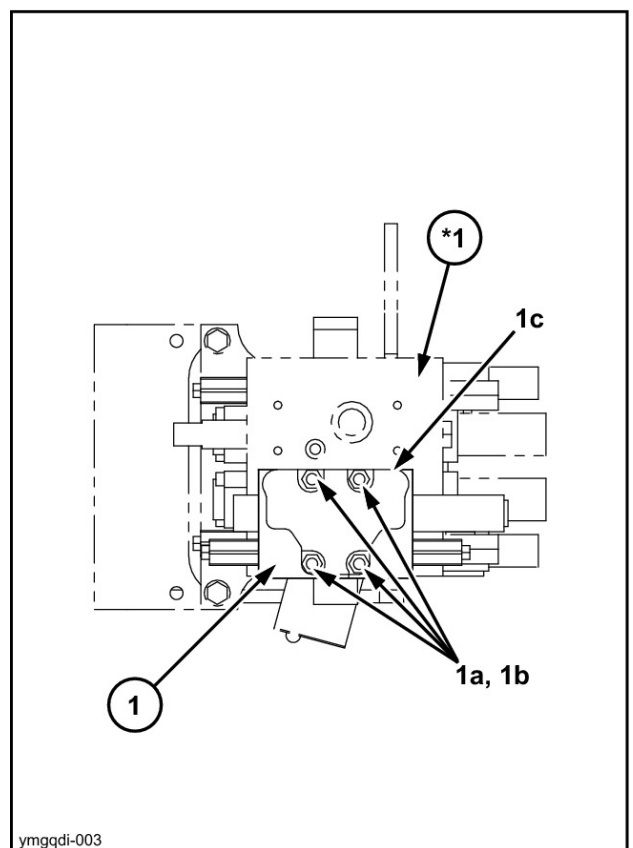

YMGQDI-003 2

3. Montare l'adattatore del flessibile (18) sul foro BR2 del distributore (*2).

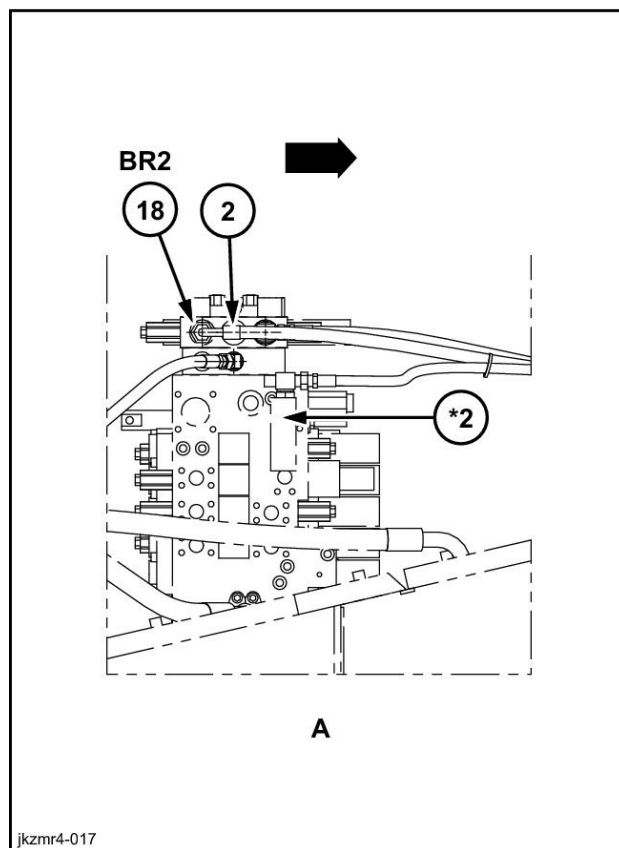

JKZMR4-017 4

4. Collegare il foro BR2 del distributore (*2) e il gruppo linea (destro) (*4) al flessibile idraulico (2).

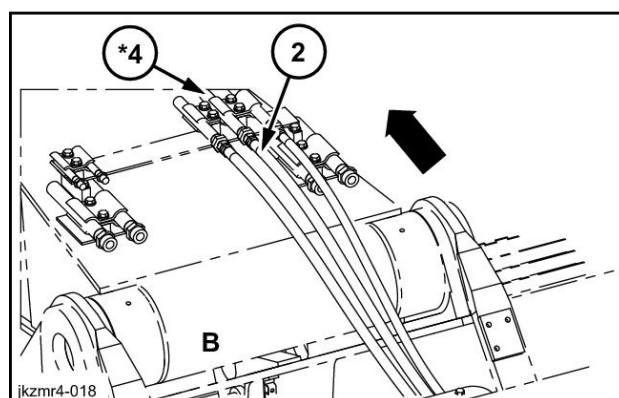

JKZMR4-018 5

2. Montare l'adattatore del flessibile (7) sul foro T5 del collettore (*2). Collegare il foro T del comando remoto dell'opzione (*1) e il foro T5 del collettore (*2) al flessibile del gruppo (3)/ (T6).

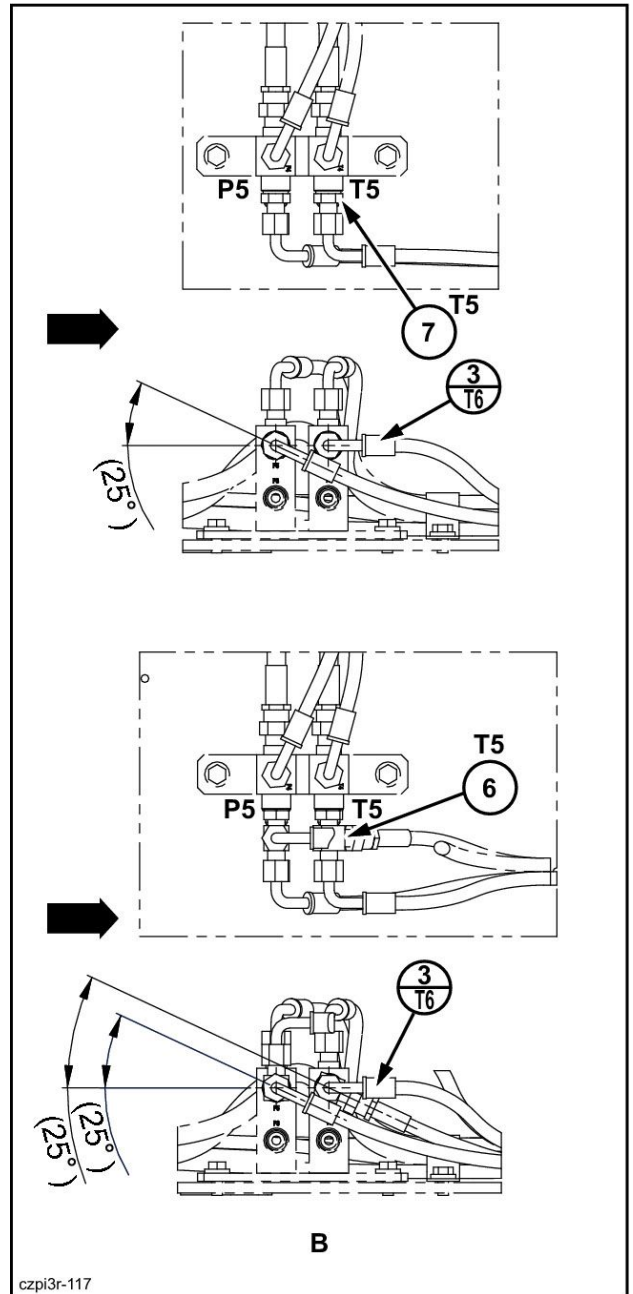

CZPI3R-117 5

3. Montare l'ugello (12) sul foro P del comando remoto dell'opzione (*1).

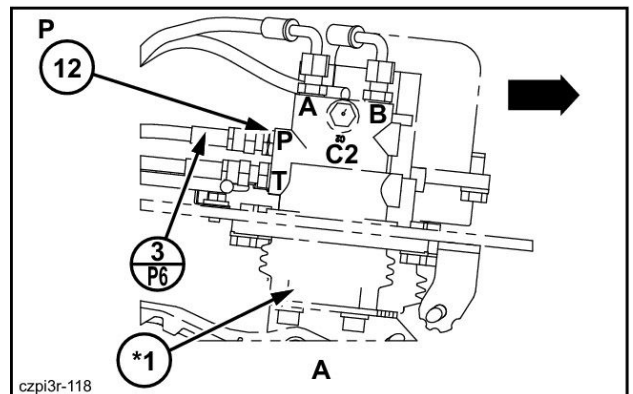

CZPI3R-118 6

CLICK HERE TO **DOWNLOAD** THE COMPLETE MANUAL

- Thank you very much for reading the preview of the manual.
- You can download the complete manual from: www.heydownloads.com by clicking the link below



- Please note: If there is no response to CLICKING the link, please download this PDF first and then click on it.

CLICK HERE TO **DOWNLOAD** THE COMPLETE MANUAL