



INSTALLATION INSTRUCTIONS

KG1BP630-00

**QUICK COUPLER LINE KIT (BOOM LINE) WITH HOSE BURST CHECK VALVE
(HBCV)**

APPROXIMATE INSTALLATION TIME: 8.0 hours

CLICK HERE TO **DOWNLOAD** THE COMPLETE MANUAL

- Thank you very much for reading the preview of the manual.
- You can download the complete manual from: www.heydownloads.com by clicking the link below



- Please note: If there is no response to CLICKING the link, please download this PDF first and then click on it.

CLICK HERE TO **DOWNLOAD** THE COMPLETE MANUAL

6. Install the seating (boom top, QC) (4) with two sems bolts (9).
 Install the two screw caps (10) on the seating (boom top, QC) (4).
 Install the two body unions (19) and two plugs (24) on the front ends of the line assembly (left) (12) and line assembly (right) (14).
 Fasten the line assembly (left) (12) and line assembly (right) (14) with the pipe clamp (16) and sems bolt (8).
- Fasten the pipe clamp (16) at a position **100 mm (3.937 in)** from the front ends of the body unions (19).

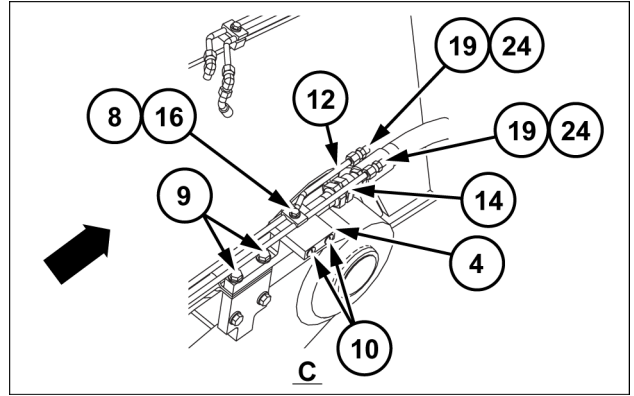

SMIL15CEXY596AB 7

7. Install the pipe clamp (17) and seating (boom cylinder bottom, QC) (6) with two sems bolts (9).
 Install the two screw caps (10) on the seating (boom cylinder bottom, QC) (6).
 Fasten the line assembly (left) (12) and line assembly (right) (14) with the pipe clamp (16) and sems bolt (8).
- Fasten the pipe clamp (16) at a position **800 mm (31.496 in)** from the pipe clamp (16) in diagram C.

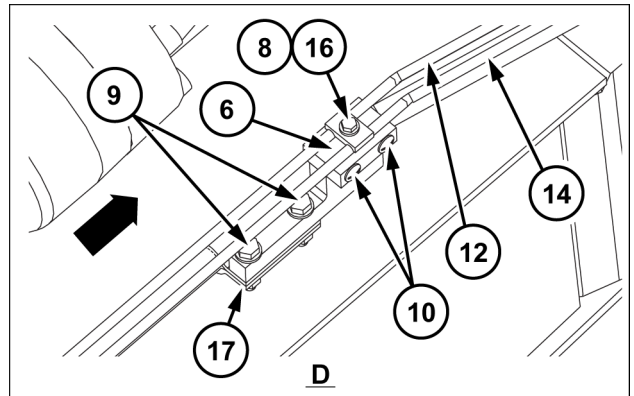

SMIL15CEXY582AB 8

8. Install the seating (boom cylinder bottom, QC) (6) with two sems bolts (9).
 Install the two screw caps (10) on the seating (boom cylinder bottom, QC) (6).
 Fasten the line assembly (left) (12) and line assembly (right) (14) with the pipe clamp (16) and sems bolt (8).
- Fasten the pipe clamp (16) at a position **750 mm (29.528 in)** from the pipe clamp (16) in diagram D.

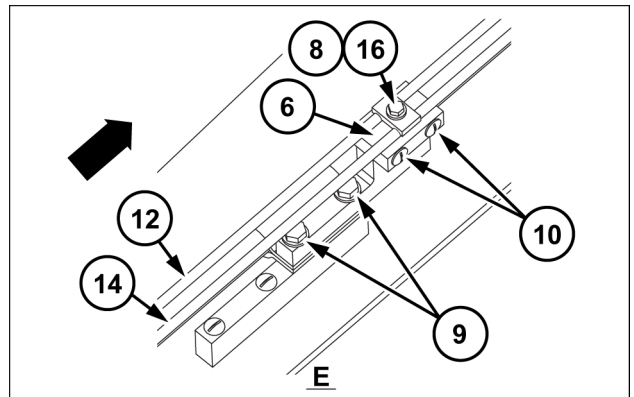

SMIL15CEXY597AB 9

9. Install the pipe clamp (17) and seating (boom cylinder bottom, QC) (6) with two sems bolts (9).
 Install the two screw caps (10) on the seating (boom cylinder bottom, QC) (6).
 Fasten the line assembly (left) (12) and line assembly (right) (14) with the pipe clamp (16) and sems bolt (8).
 Sandwich the line assembly (left) (12) with the seating (stopper, BU, QC) (1) and pipe clamp (15), and then fasten with the sems bolt (22).
- Fasten the seating (stopper, BU, QC) (1) at a position **480 mm (18.898 in)** from the pipe clamp (16) in diagram E.

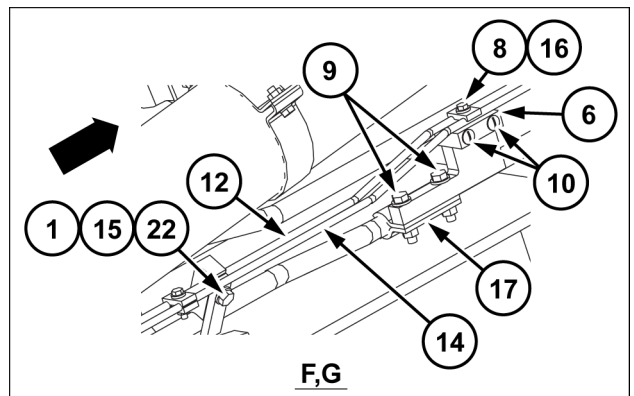

SMIL15CEXY598AB 10

2 - VORMONTAGE

VORBEREITUNG ZUR MONTAGE

Vorbereitung

Ein „*“ in diesem Dokument weist darauf hin, dass das Teil an der vorliegenden Maschine verbaut ist.

Vorzubereitende Elemente:

- Schraubenschlüssel (**13 mm, 19 mm**)
- Ringschlüssel (**13 mm, 19 mm**)
- Sechskantschlüssel (**12 mm**)
- Hebekran
- Schweißgerät
- Lappen

1. Bringen Sie die Haupteinheit in Position.
 - Die Haupteinheit auf einem festen und flachen Untergrund abstellen, den Löffelzylinder bis zum Anschlag ausfahren, den Pendelarmzylinder bis zum Anschlag ausfahren, den Ausleger senken und mit dem Pendelarmoberteil den Boden berühren.

2. Schalten Sie den Zündschlüssel auf „OFF“ (AUS) (**a**), vergewissern Sie sich, dass der Motor gestoppt ist, und schalten Sie dann den Zündschlüssel wieder auf „ON“ (EIN). (Den Motor nicht starten.)

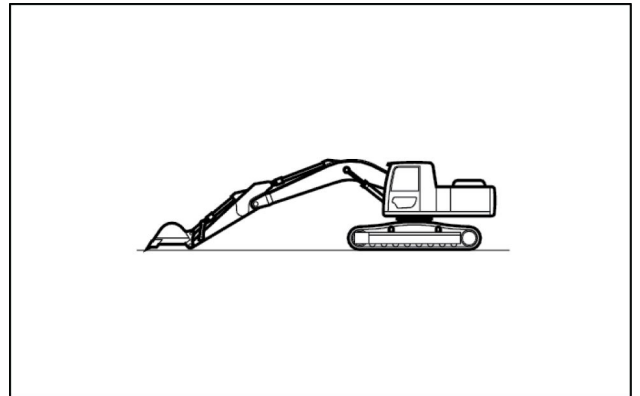

SMIL13II00106AA 1

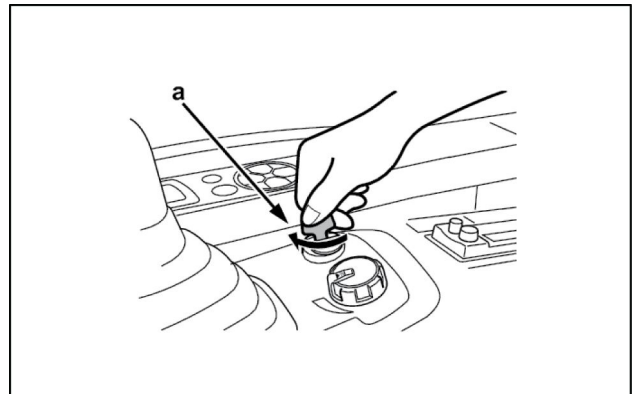

SMIL13II00107AA 2

Sommaire

1 CONTENU DU KIT

Contenu du kit 1-1

2 AVANT-ASSEMBLAGE

PREPARATION POUR L'ASSEMBLAGE

Préparation 2-1

3 ASSEMBLAGE

KIT DE CONDUITE POUR RACCORD RAPIDE (POUR FLECHE STANDARD) AVEC CLAPET ANTI-RETOUR EN CAS DE RUPTURE DE FLEXIBLE (HBCV)

Pose des conduites de flèche 3-1

Index

	C	
Contenu du kit		1-1
	P	
Pose des conduites de flèche		3-1
Préparation		2-1

3 - MONTAGGIO

KIT TUBAZIONE ATTACCO RAPIDO (PER AVAMBRACCIO STANDARD) CON VALVOLA DI RITEGNO SCOPPIO FLESSIBILI (HBCV)

Montaggio della tubazione del braccio

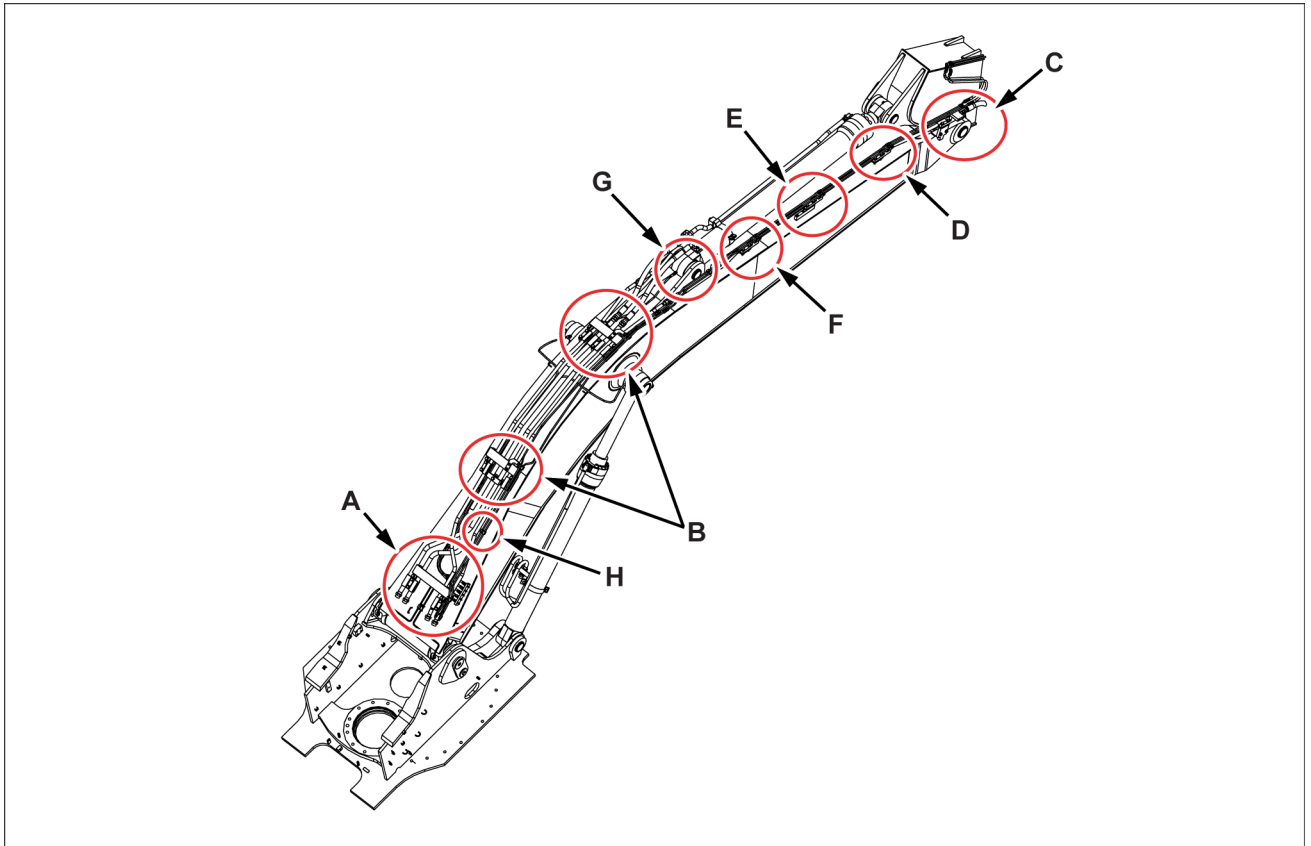

SMIL15CEXY576FB 1

Applicare **LOCTITE® (20)** alla sezione filettata dei bulloni tipo Sems e dei bullone ad alta resistenza.

1. Utilizzare una gru o un attrezzatura simile, per posizionare il complessivo tubazione (lato sinistro) **(11)** e il complessivo tubazione (lato destro) **(13)** sul braccio.

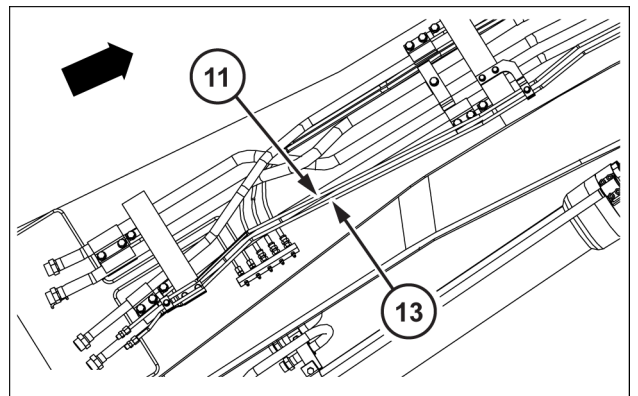

SMIL15CEX8403AB 2

1 - CONTENIDO DEL KIT

Contenido del kit

NOTA: consulte el manual de piezas para los pedidos.

Pluma estándar (consulte 3-1)

Elemento	Descripción	Cantidad	Referencia
1	Asiento (tope - unión BU - acoplador rápido)	1	KRV46000
2	Asiento (centro de la pluma - acoplador rápido)	2	KHV13670
4	Asiento (tope de la pluma - acoplador rápido)	1	KBV40880
6	Asiento (base del cilindro de la pluma - acoplador rápido)	3	KBV39060
7	Tuerca M8	2	162R008SR
8	Perno SEMS M8x25	8	105R008Y025R
9	Perno SEMS M12x60	8	105R012Y060R
10	Tapa con rosca	8	KHV12270
11	Conjunto de conductos (izquierdo)	1	KBV38880
12	Conjunto de conductos (izquierdo)	1	KBV40840
13	Conjunto de conductos (derecho)	1	KBV38890
14	Conjunto de conductos (derecho)	1	KBV40850
15	Abrazadera	1	KRV46010
16	Abrazadera	11	KHV13660
17	Abrazadera	2	KHV13330
18	Unión	2	KMJ0602
19	Unión	4	KMJ0708
20	LOCTITE®	1	KRC5007
21	Perno de alta resistencia M8x35	5	102R008Y035R
22	Perno SEMS M12 x 30	1	105R012Y030R
23	Arandela de alta resistencia M8	5	KAJ1500
24	Tapón G1/4	2	KHJ0632

CLICK HERE TO **DOWNLOAD** THE COMPLETE MANUAL

- Thank you very much for reading the preview of the manual.
- You can download the complete manual from: www.heydownloads.com by clicking the link below



- Please note: If there is no response to CLICKING the link, please download this PDF first and then click on it.

CLICK HERE TO **DOWNLOAD** THE COMPLETE MANUAL