



INSTALLATION INSTRUCTIONS

746400050

746400060

SECOND AUXILIARY CIRCUIT KIT

APPROXIMATE INSTALLATION TIME: 6.0 hours

CLICK HERE TO **DOWNLOAD** THE COMPLETE MANUAL

- Thank you very much for reading the preview of the manual.
- You can download the complete manual from: www.heydownloads.com by clicking the link below



- Please note: If there is no response to CLICKING the link, please download this PDF first and then click on it.

CLICK HERE TO **DOWNLOAD** THE COMPLETE MANUAL

4 - PRE-ASSEMBLY

PREPARING FOR ASSEMBLY

Preparation

1. Position the machine.
 - Park the machine on a level and firm surface with the upper structure turned by **90°** in order to make access easier.
 - Fully retract the arm cylinder and the bucket cylinder.
 - Lower the bucket to the ground.
 - Lower the dozer to the ground.

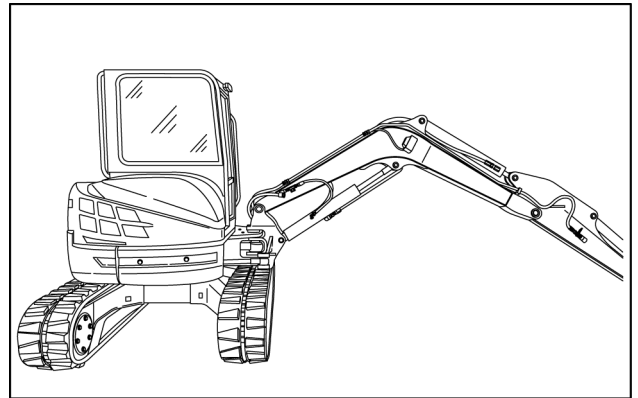

SMIL13MEX0384AA 1

2. Unload the hydraulic lines.
 - Shut down the engine and set the starter key to ON position.
 - Press the left and right side of the pedal for **2 s** each.

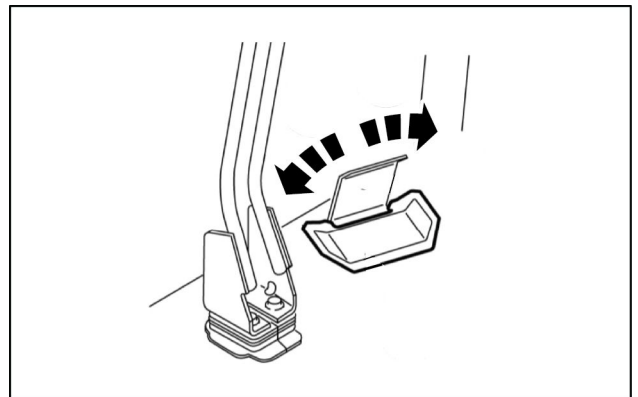

SMIL13MEX0435AA 2

3. Bleed out the pressure inside the hydraulic oil tank.
 - Open the right hood (**A**).
 - Press the rubber cap (**B**) on the upper surface of the hydraulic oil tank several times (5 to 7 times).
4. Fit a vacuum device to avoid leaking of the hydraulic oil during the installation.

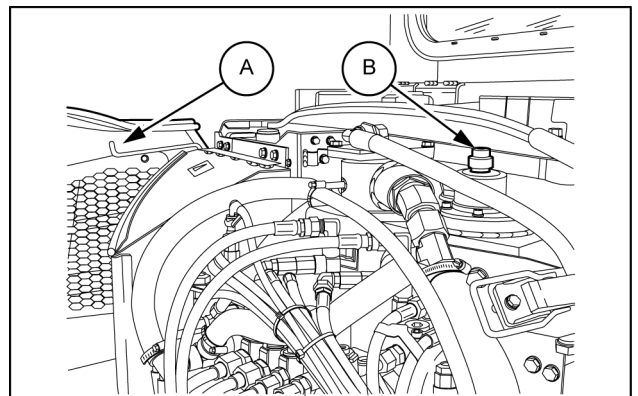

SMIL13MEX0385AB 3

8. Loosen the screws **(D)** and remove the bracket **(E)** from the grommet **(F)** into the front upper frame near the swing bracket.
9. Direct two hoses **(22)** towards the switch valve, passing them through the grommet **(F)**.
You can use the floor mat opening space for helping you to pull the hoses **(22)** from the boom towards the switch valve.

(RH): from the right boom side to the F port on the switch valve

(LH): from the left boom side to the D port on the switch valve

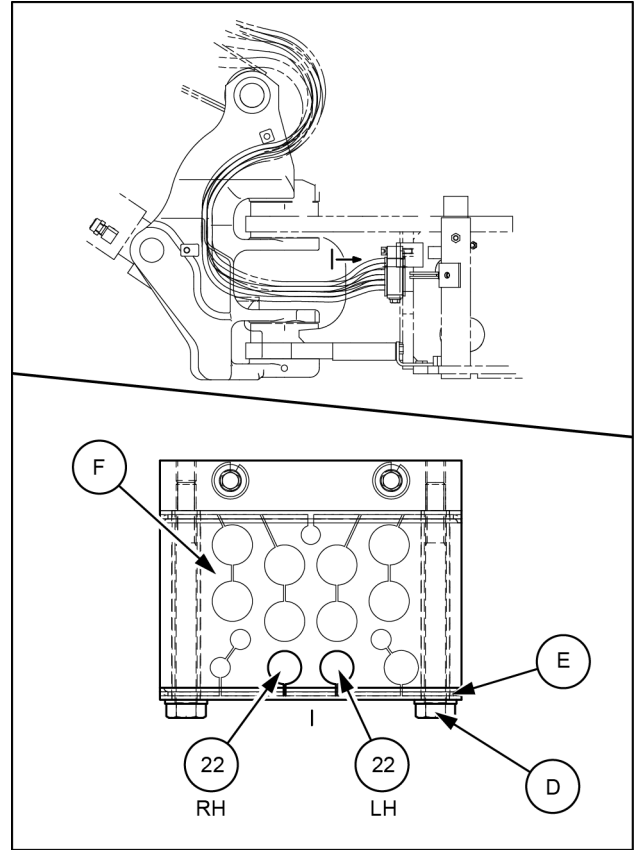

SMIL13MEX0490BB 7

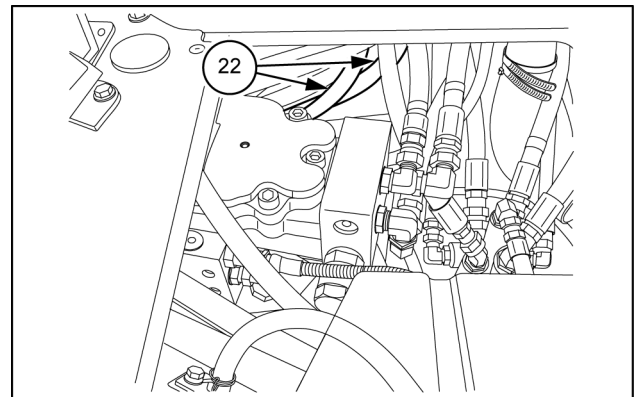

SMIL13MEX0404AB 8

10. Connect two hoses **(22)** to the D and F ports of the switch valve **(14)** without tightening.
The hose **(22)** connected to the D port goes to the left side of the boom.
The hose **(22)** connected to the F port goes to the right side of the boom.

- Wrench: **22 mm**

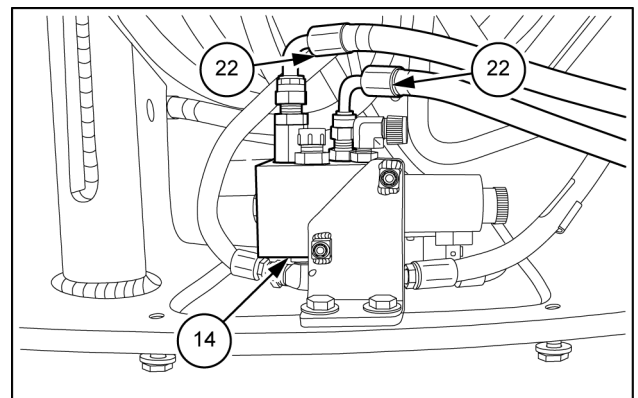

SMIL13MEX0405AB 9

8. Lift the rubber boot (I) of the left control lever.
9. Disassemble the cover (J) from the cover (K) on the left control lever.

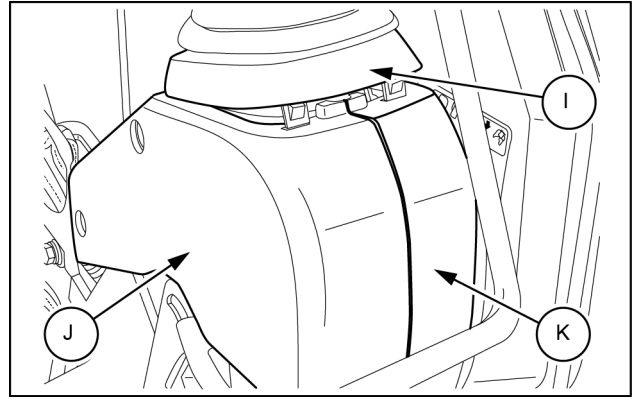

SMIL13MEX0427AB 5

10. Wipe off any dirt from the cover (34) and attach the label (27).
11. Fit the selector switch (31) to the cover (34).
12. Connect the harness (32) to the selector switch (31).

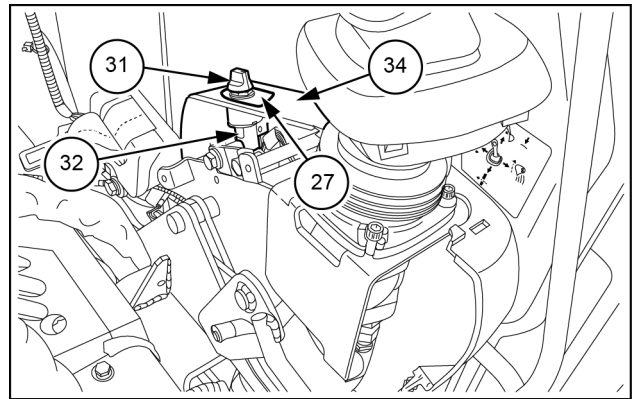

SMIL13MEX0428AB 6

13. Connect the harness (32) to the connector labeled **CN-42** of the main harness, sliding it along the rubber sleeve (L).
14. Fasten the harness (32) by means of the tie cables (33), putting the harness under the right console.

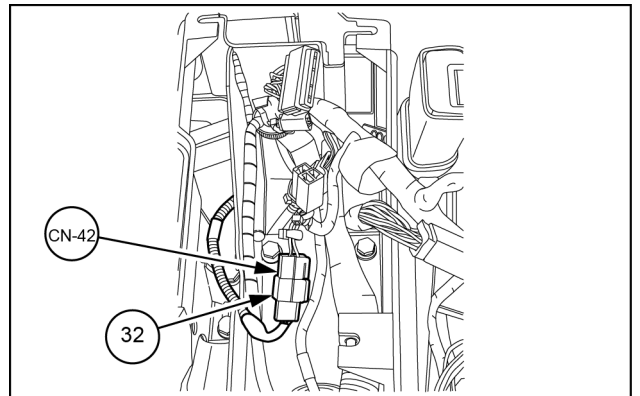

SMIL13MEX0429AB 7

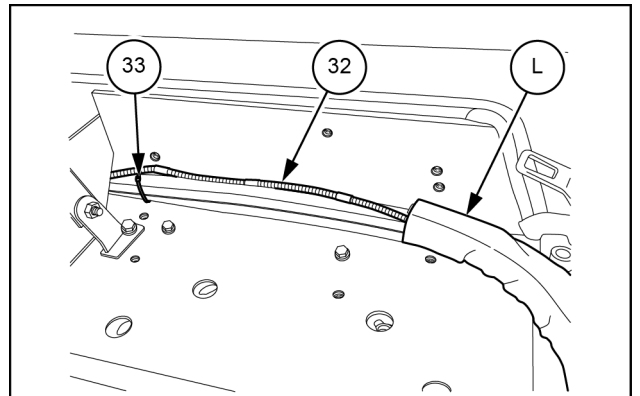

SMIL13MEX0430AB 8



INSTALLATIONSANWEISUNG

746400050

746400060

MONTAGESATZ ZWEITER ZUSATZGERÄTESATZ

UNGEFÄHRE EINBAUZEIT: 6.0 Stunden

4 - VORMONTAGE

VORBEREITUNG ZUR MONTAGE

Vorbereitung

1. Positionieren Sie die Maschine.
 - Parken Sie die Maschine auf ebenem Boden, und drehen Sie den Oberwagen um **90°**, um den Zugang zu erleichtern.
 - Fahren Sie den Armzylinder und Löffelzylinder ganz ein.
 - Senken Sie den Löffel auf den Boden ab.
 - Senken Sie den Planierschild auf den Boden ab.

2. Bauen Sie den Druck in den Hydraulikleitungen ab.
 - Schalten Sie den Motor ab, und schalten Sie den Zündschlüssel in die Position EIN.
 - Drücken Sie die linke Seite und die rechte Seite des Pedals um jeweils **2 s**.

3. Lassen Sie den Druck aus dem Hydraulikölbehälter ab.
 - Öffnen Sie die rechte Haube **(A)**.
 - Drücken Sie den Gummistopfen **(B)** auf der Oberseite des Hydraulikölbehälters einige Male (5 bis 7 Mal).

4. Bringen Sie eine Unterdruckvorrichtung an, um Hydrauliköllecks während der Montage zu vermeiden.

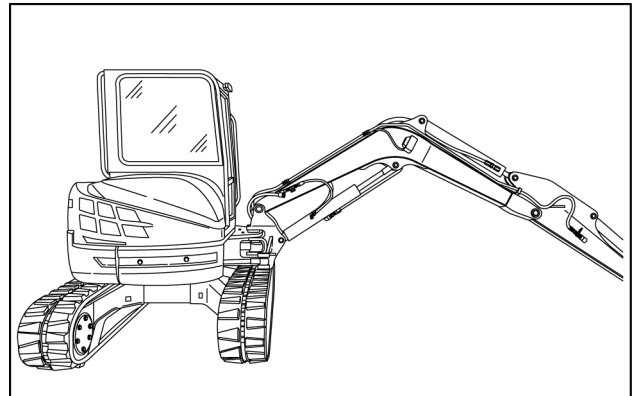

SMIL13MEX0384AA 1

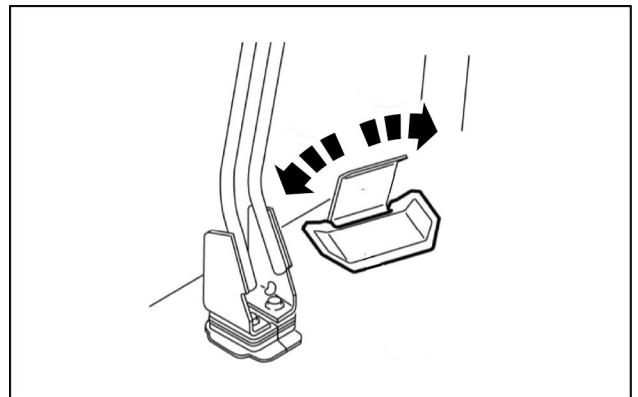

SMIL13MEX0435AA 2

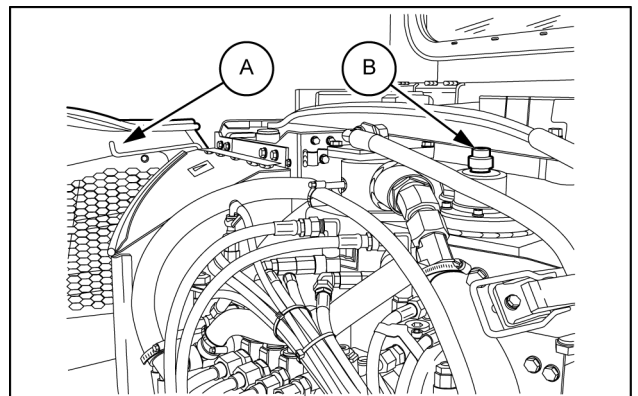

SMIL13MEX0385AB 3

8. Lösen Sie die Schrauben (**D**) und entfernen Sie die Halterung (**E**) von der Tülle (**F**) im vorderen oberen Rahmen neben der Schwenkhalterung.
9. Verlegen Sie zwei Schläuche (**22**) in Richtung des Umschaltventils durch die Gummitülle (**F**). Sie können die Bodenmattenöffnung verwenden, um die Schläuche (**22**) vom Ausleger in Richtung Umschaltventil zu ziehen.

(RH): Von der rechten Auslegerseite zum Anschluss F auf dem Umschaltventil

(LH): Von der linken Auslegerseite zum Anschluss D auf dem Umschaltventil

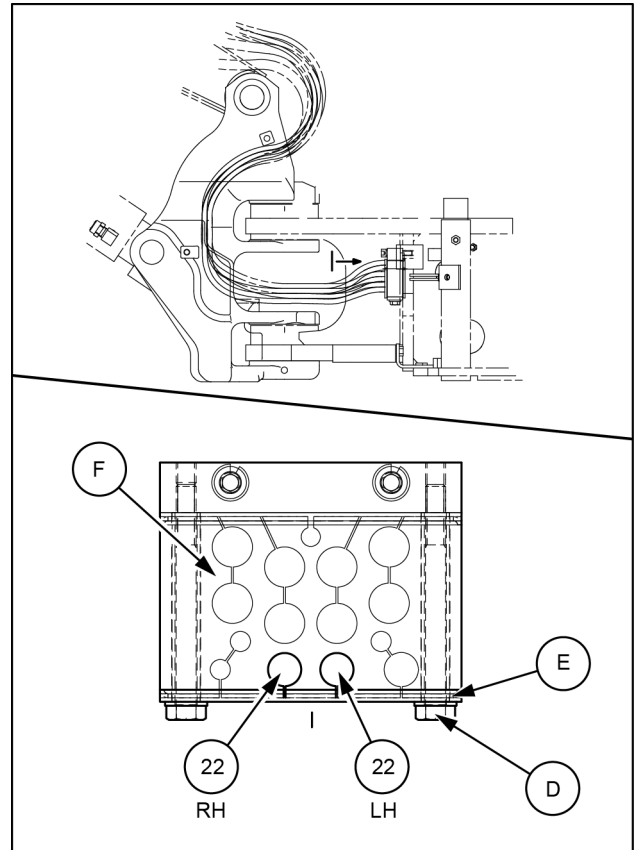

SMIL13MEX0490BB 7

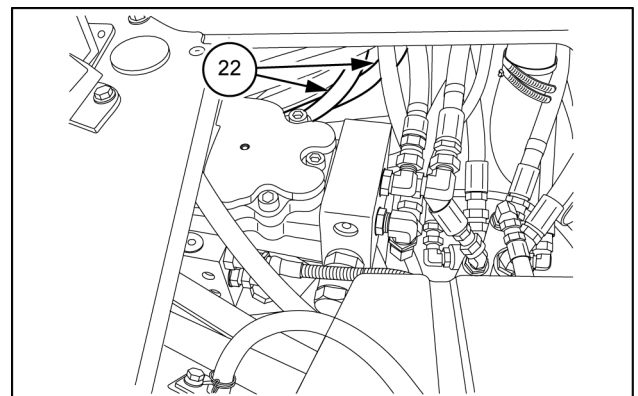

SMIL13MEX0404AB 8

10. Verbinden Sie die beiden Schläuche (**22**) an den Anschlüssen D und F des Umschaltventils (**14**), ohne sie festzuziehen. Der Schlauch (**22**) an Anschluss D führt auf die linke Seite des Auslegers. Der Schlauch (**22**) an Anschluss F führt auf die rechte Seite des Auslegers.

- Schraubenschlüssel: **22 mm**

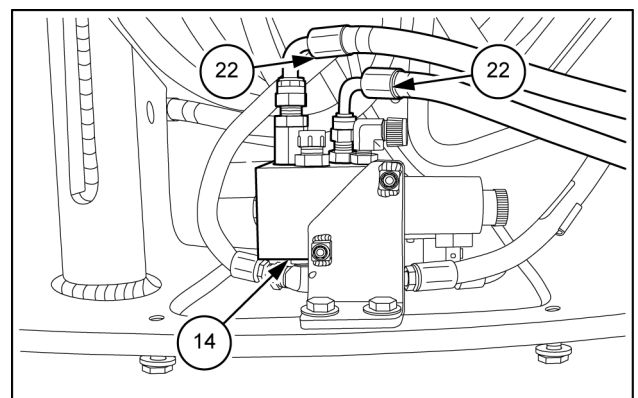

SMIL13MEX0405AB 9

8. Heben Sie die Gummimanschette (**I**) des linken Steuerhebels an.
9. Demontieren Sie die Abdeckung (**J**) von der Abdeckung (**K**) am linken Steuerhebel.

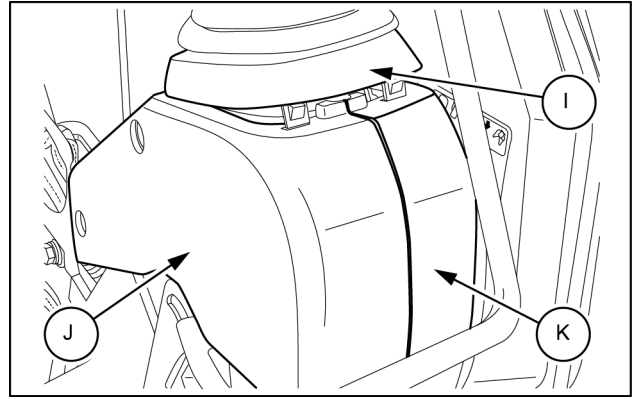

SMIL13MEX0427AB 5

10. Wischen Sie den Schmutz von der Abdeckung (**34**) ab, und bringen Sie das Etikett (**27**) an.
11. Montieren Sie den Wahlschalter (**31**) an der Abdeckung (**34**).
12. Schließen Sie den Kabelbaum (**32**) an den Wahlschalter (**31**) an.

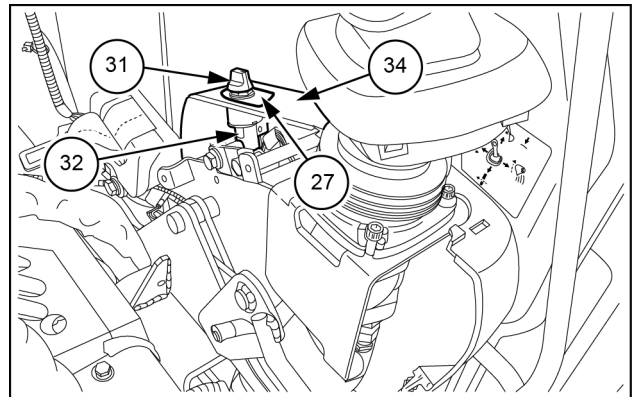

SMIL13MEX0428AB 6

13. Schließen Sie den Kabelbaum (**32**) an den Steckverbinder des Hauptkabelbaums mit der Beschriftung **CN-42** an, und schieben Sie ihn entlang der Gummimuffe (**L**).
14. Befestigen Sie den Kabelbaum (**32**) mit Hilfe der Kabelbinder (**33**), indem Sie den Kabelbaum unter der rechten Konsole positionieren.

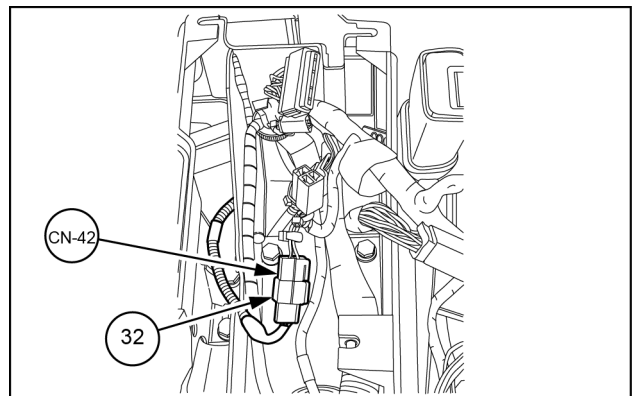

SMIL13MEX0429AB 7

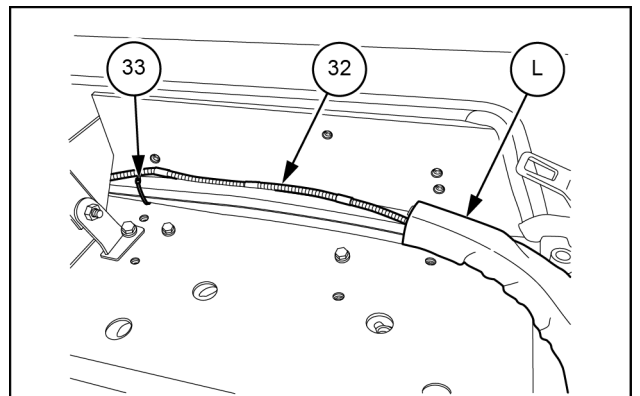

SMIL13MEX0430AB 8



INSTRUCTIONS D'INSTALLATION

746400050

746400060

KIT DE SECOND CIRCUIT AUXILIAIRE

TEMPS D'INSTALLATION APPROXIMATIF : 6.0 heure(s)

4 - AVANT-ASSEMBLAGE

PREPARATION POUR L'ASSEMBLAGE

Préparation

1. Positionner la machine.
 - Stationner la machine sur une surface plane et ferme avec la structure supérieure tournée à **90 °** pour faciliter l'accès.
 - Rétracter complètement le vérin de bras et le vérin de godet.
 - Abaissez le godet au sol.
 - Abaisser la lame au sol.

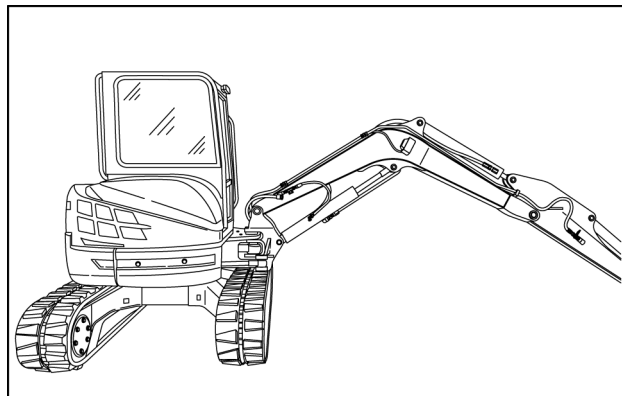

SMIL13MEX0384AA 1

2. Décharger les conduites hydrauliques.
 - Arrêter le moteur et mettre la clé de contact en position ON.
 - Appuyer sur les côtés gauche et droit de la pédale pendant **2 s** de chaque côté.

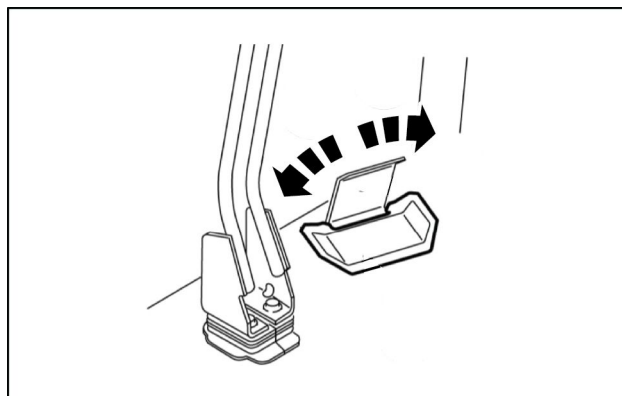

SMIL13MEX0435AA 2

3. Evacuer la pression à l'intérieur du réservoir d'huile hydraulique.
 - Ouvrir le capot droit (**A**).
 - Appuyer plusieurs fois (5 à 7 fois) sur le capuchon en caoutchouc (**B**) situé sur la surface supérieure du réservoir d'huile hydraulique.
4. Installer un dispositif à dépression pour éviter toute fuite d'huile hydraulique lors de l'installation.

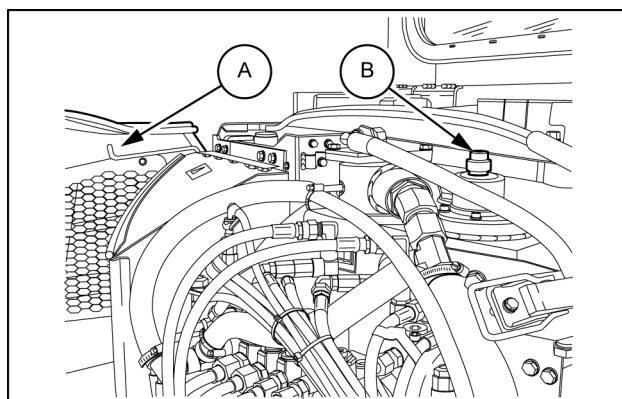

SMIL13MEX0385AB 3

CLICK HERE TO **DOWNLOAD** THE COMPLETE MANUAL

- Thank you very much for reading the preview of the manual.
- You can download the complete manual from: www.heydownloads.com by clicking the link below



- Please note: If there is no response to CLICKING the link, please download this PDF first and then click on it.

CLICK HERE TO **DOWNLOAD** THE COMPLETE MANUAL

8. Dévisser les vis (**D**) et retirer le support (**E**) du passe-fil (**F**) dans le châssis supérieur avant, à proximité du support de pivotement.
9. Diriger les deux flexibles (**22**) vers la vanne de commutation en les faisant passer à travers le passe-fil (**F**). Utiliser l'ouverture du tapis de sol pour tirer plus facilement les flexibles (**22**) entre la flèche et la vanne de commutation.

(RH) : entre le côté droit de la flèche et l'orifice F sur la vanne de commutation

(LH) : entre le côté gauche de la flèche et l'orifice D sur la vanne de commutation

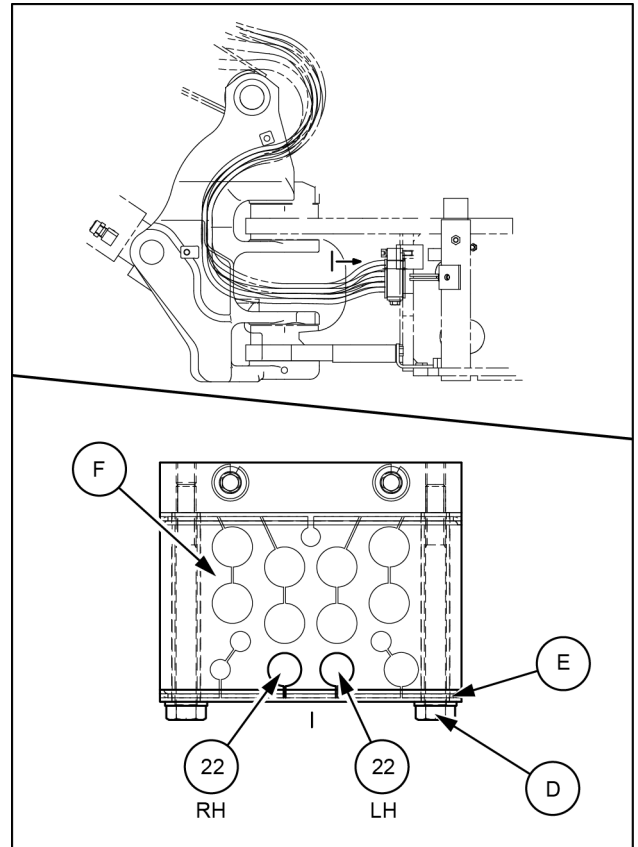

SMIL13MEX0490BB 7

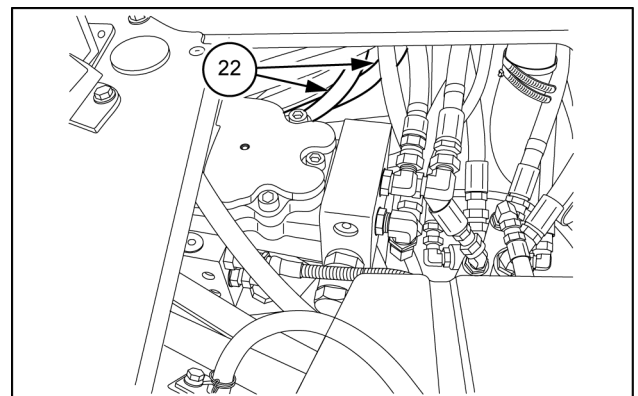

SMIL13MEX0404AB 8

10. Brancher les deux flexibles (**22**) aux orifices D et F de la vanne de commutation (**14**), sans les serrer. Le flexible (**22**) branché à l'orifice D est dirigé vers le côté gauche de la flèche. Le flexible (**22**) branché à l'orifice F est dirigé vers le côté droit de la flèche.

- Clé : **22 mm**

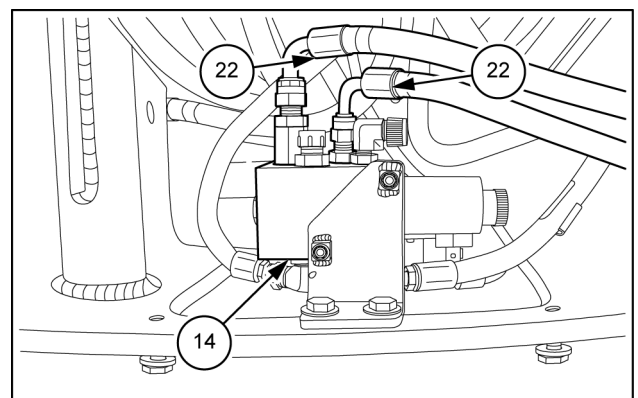

SMIL13MEX0405AB 9

8. Soulever le soufflet en caoutchouc **(I)** du levier de commande gauche.
9. Détacher le couvercle **(J)** du couvercle **(K)** sur le levier de commande gauche.

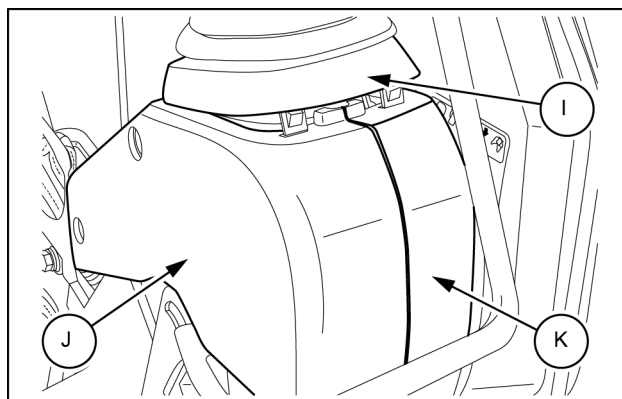

SMIL13MEX0427AB 5

10. Dépoussiérer le couvercle **(34)** et fixer l'étiquette **(27)**.
11. Installer le sélecteur **(31)** sur le couvercle **(34)**.
12. Brancher le faisceau **(32)** sur le sélecteur **(31)**.

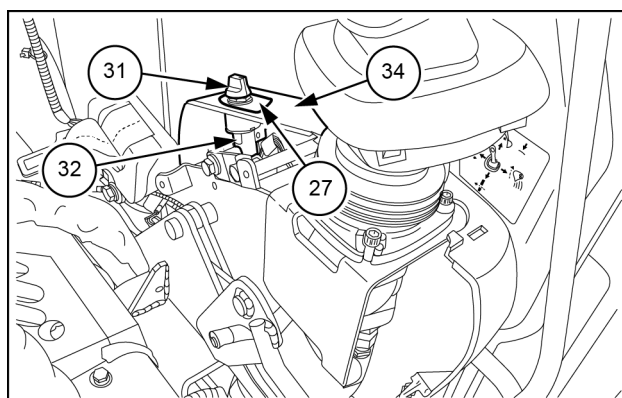

SMIL13MEX0428AB 6

13. Brancher le faisceau **(32)** au connecteur étiqueté **CN-42** du faisceau principal en le faisant glisser le long du manchon en caoutchouc **(L)**.
14. Fixer le faisceau **(32)** à l'aide des attaches pour câbles **(33)**, en plaçant le faisceau sous la console droite.

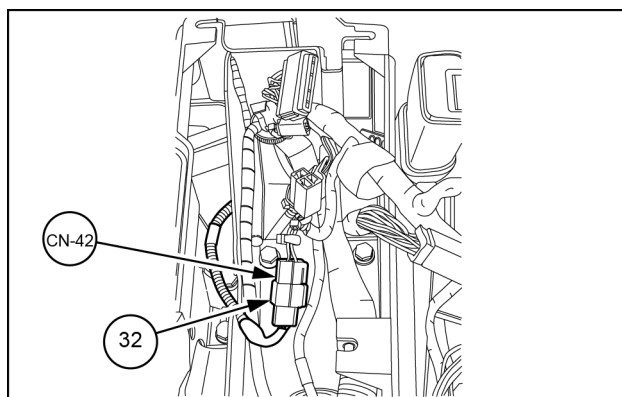

SMIL13MEX0429AB 7

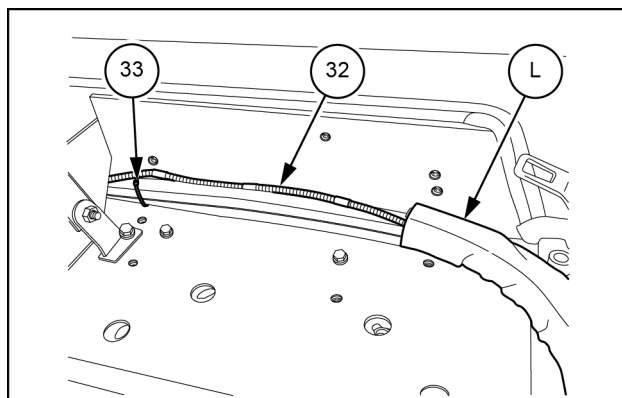

SMIL13MEX0430AB 8



ISTRUZIONI DI MONTAGGIO

746400050

746400060

KIT SECONDO CIRCUITO AUSILIARIO

TEMPO DI MONTAGGIO APPROSSIMATIVO: 6.0 ore

4 - PRE-ASSEMBLAGGIO

OPERAZIONI PRELIMINARI PER IL MONTAGGIO

Preparazione

1. Posizionare la macchina.
 - Parcheggiare la macchina su una superficie piana e solida con la torretta ruotata di **90°** per agevolare l'accesso.
 - Ritrarre completamente il cilindro avambraccio e il cilindro benna.
 - Abbassare la benna al suolo.
 - Abbassare l'apripista al suolo.

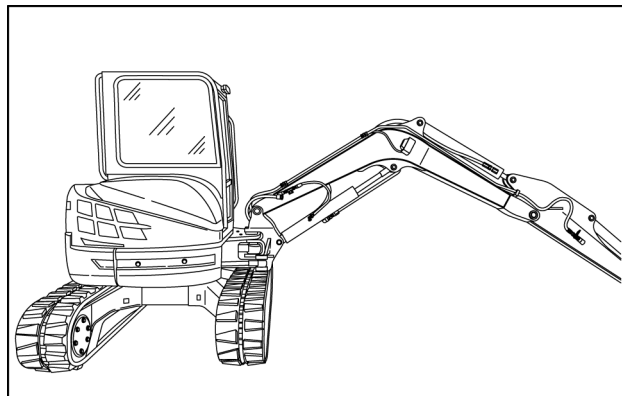

SMIL13MEX0384AA 1

2. Scaricare le tubazioni idrauliche.
 - Arrestare il motore e portare la chiave di avviamento in posizione ON.
 - Premere il lato sinistro e destro del pedale per **2 s** ciascuno.

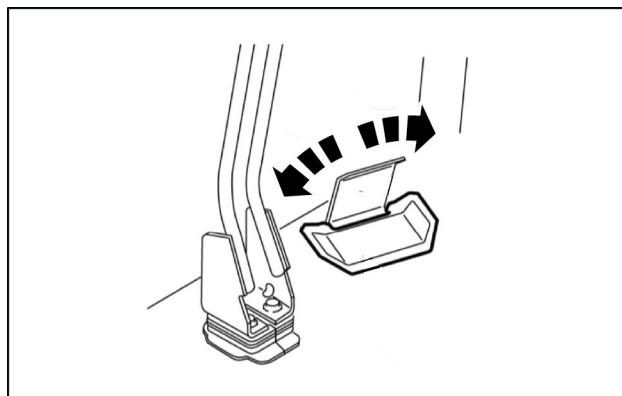

SMIL13MEX0435AA 2

3. Scaricare la pressione all'interno del serbatoio olio idraulico.
 - Aprire il cofano destro (**A**).
 - Premere diverse volte (da 5 a 7) il tappo in gomma (**B**) sulla superficie superiore del serbatoio olio idraulico.
4. Montare un dispositivo del vuoto per evitare perdite di olio idraulico durante il montaggio.

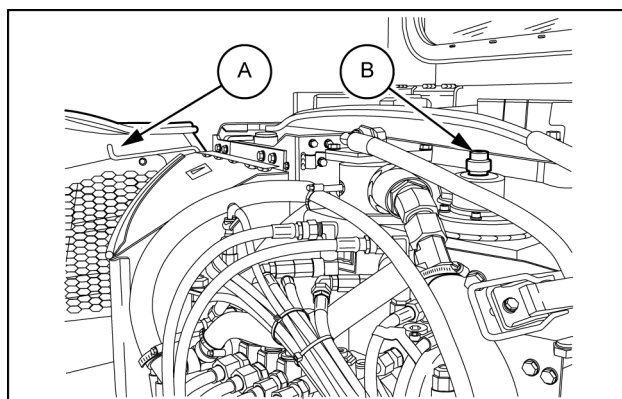

SMIL13MEX0385AB 3

8. Allentare le viti (**D**) e smontare la staffa (**E**) dall'anello passacavo (**F**) nel telaio superiore anteriore accanto alla staffa di supporto brandeggio.

9. Dirigere due tubi flessibili (**22**) verso la valvola interruttore, facendoli passare attraverso l'anello passacavo (**F**).

È possibile utilizzare lo spazio nell'apertura del tappetino per facilitare l'estrazione dei tubi flessibili (**22**) dal braccio verso la valvola interruttore.

(RH): dal lato del braccio destro alla luce F sulla valvola interruttore

(LH): dal lato del braccio sinistro alla luce D sulla valvola interruttore

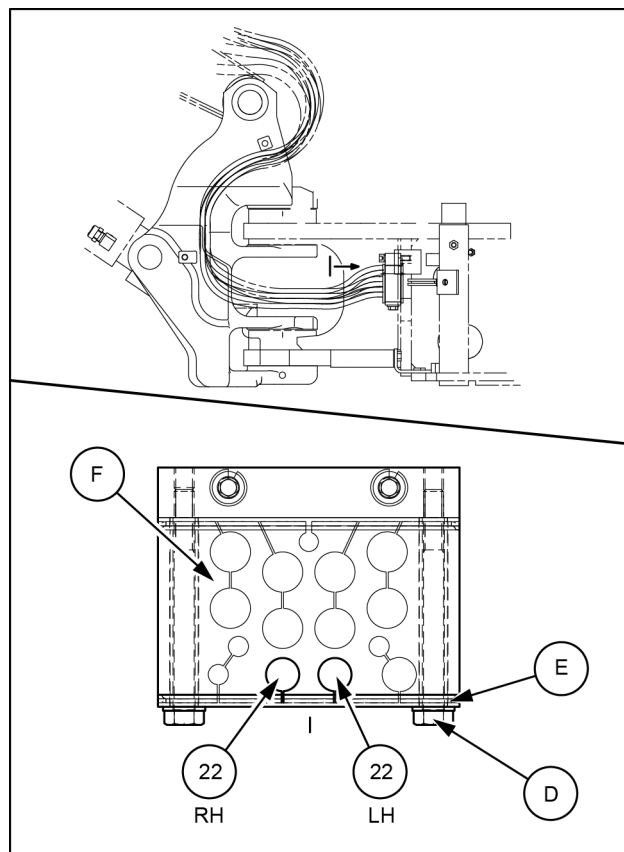

SMIL13MEX0490BB 7

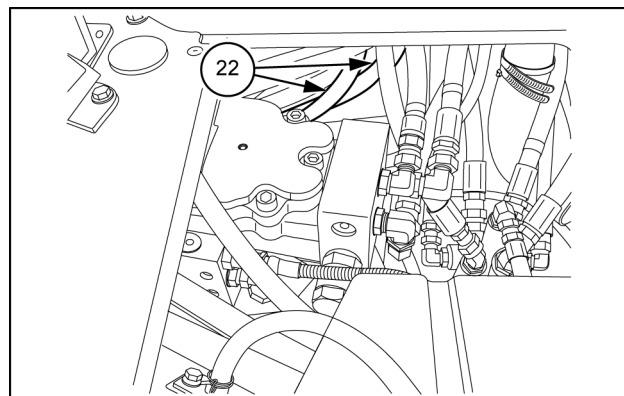

SMIL13MEX0404AB 8

10. Collegare due tubi flessibili (**22**) alle luci D ed F della valvola interruttore (**14**) senza serrare.

Il tubo flessibile (**22**) collegato alla luce D è diretto al lato sinistro del braccio.

Il tubo flessibile (**22**) collegato alla luce F è diretto al lato destro del braccio.

- Chiave: **22 mm**

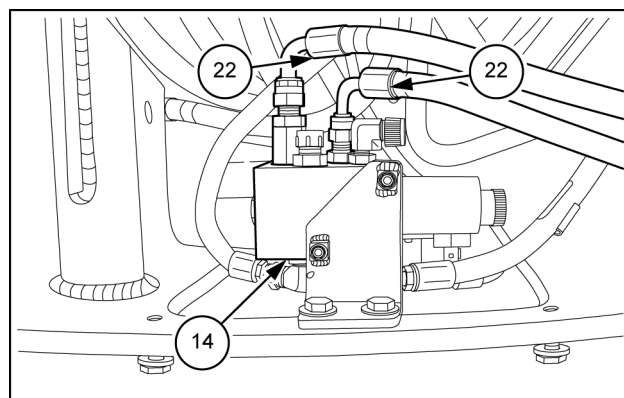

SMIL13MEX0405AB 9

8. Sollevare il parapolvere in gomma **(I)** della leva di comando sinistra.
9. Disassemblare il coperchio **(J)** dal coperchio **(K)** sulla leva di comando sinistra.

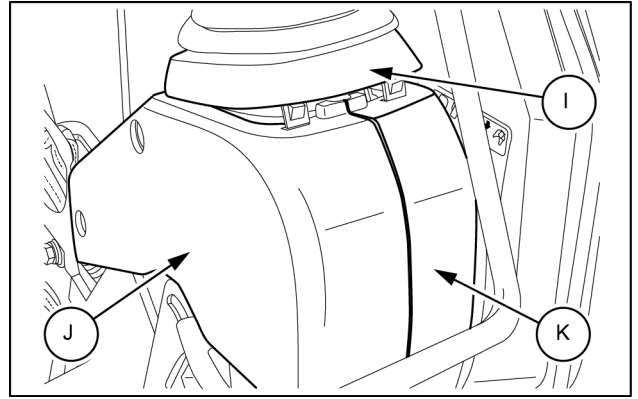

SMIL13MEX0427AB 5

10. Con un panno, rimuovere eventuale sporcizia dal coperchio **(34)** e applicare l'etichetta **(27)**.
11. Montare l'interruttore selettore **(31)** sul coperchio **(34)**.
12. Collegare il cablaggio **(32)** all'interruttore selettore **(31)**.

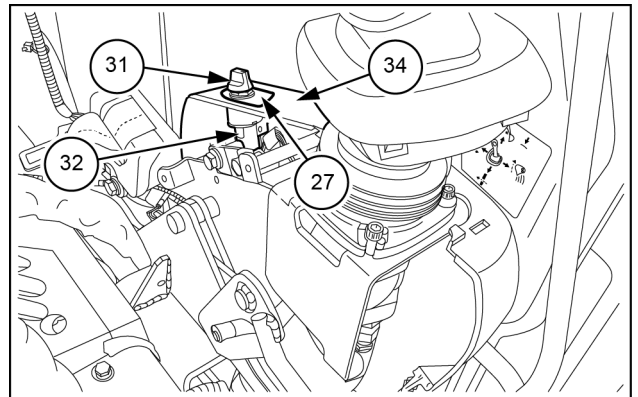

SMIL13MEX0428AB 6

13. Collegare il cablaggio **(32)** al connettore etichettato con **CN-42** del cablaggio principale, facendolo scorrere lungo il manicotto in gomma **(L)**.
14. Fissare il cablaggio **(32)** sotto la console lato destro mediante le fascette serrafili **(33)**.

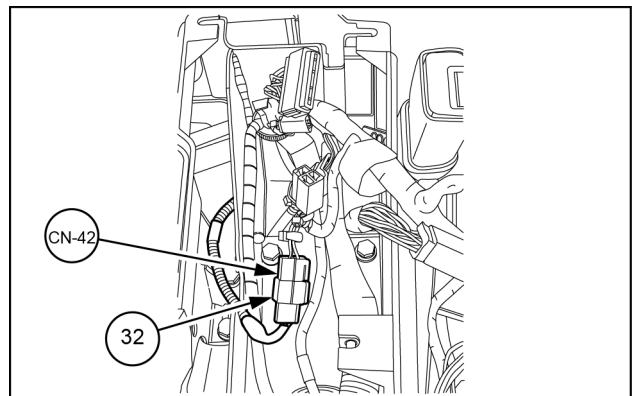

SMIL13MEX0429AB 7

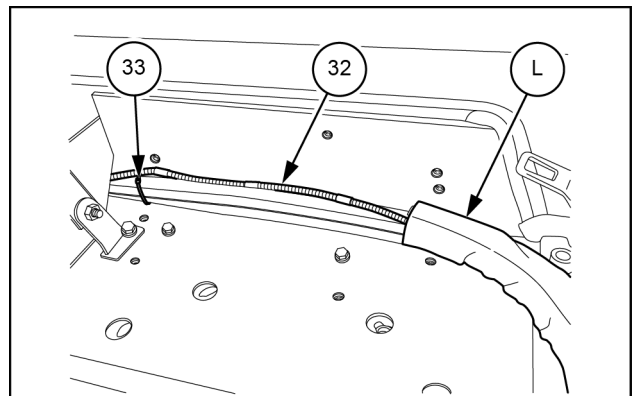

SMIL13MEX0430AB 8



INSTRUCCIONES DE INSTALACIÓN

746400050

746400060

KIT DEL SEGUNDO CIRCUITO AUXILIAR

TIEMPO DE INSTALACIÓN APROXIMADO: 6.0 horas

4 - PREENSAMBLADO

PREPARACIÓN PARA MONTAJE

Preparación

1. Coloque la máquina.
 - Estacione la máquina en una superficie plana y nivelada con la estructura superior girada **90°** para facilitar el acceso.
 - Repliegue por completo los cilindros del brazo y de la cuchara.
 - Baje la cuchara al suelo.
 - Baje la empujadora al suelo.

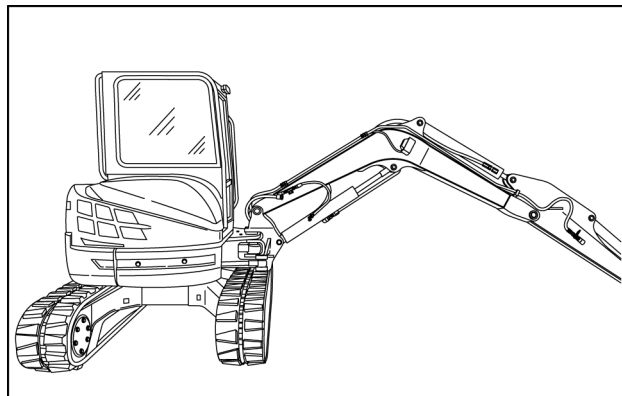

SMIL13MEX0384AA 1

2. Descargue los conductos hidráulicos.
 - Apague el motor y coloque la llave de contacto en la posición ON.
 - Presione cada lado del pedal durante **2 s**.

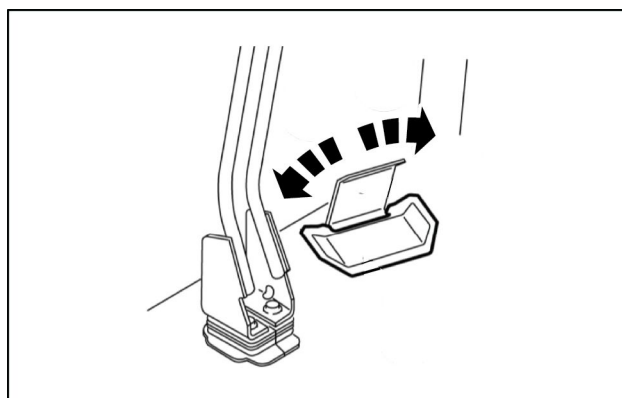

SMIL13MEX0435AA 2

3. Despresurice el interior del depósito de aceite hidráulico.
 - Abra la cubierta derecha (**A**).
 - Presione varias veces la tapa de goma (**B**) sobre la superficie superior del depósito de aceite hidráulico (entre 5 y 7 veces).
4. Monte un dispositivo de vacío para evitar fugas del aceite hidráulico durante la instalación.

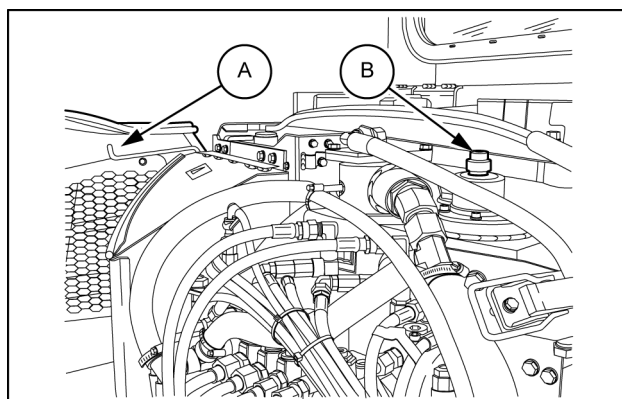

SMIL13MEX0385AB 3

8. Afloje los tornillos **(D)** y retire el soporte **(E)** del pasacables **(F)** del bastidor superior delantero, cerca del soporte oscilante.
9. Pase dos mangueras **(22)** hacia la válvula de conmutación, por el pasacables **(F)**.
Puede utilizar la abertura de la alfombrilla para ayudarse a tirar de las mangueras **(22)** desde la pluma hacia la válvula de conmutación.

(RH): desde el lado derecho de la pluma al puerto F de la válvula de conmutación

(LH): desde el lado izquierdo de la pluma al puerto D de la válvula de conmutación

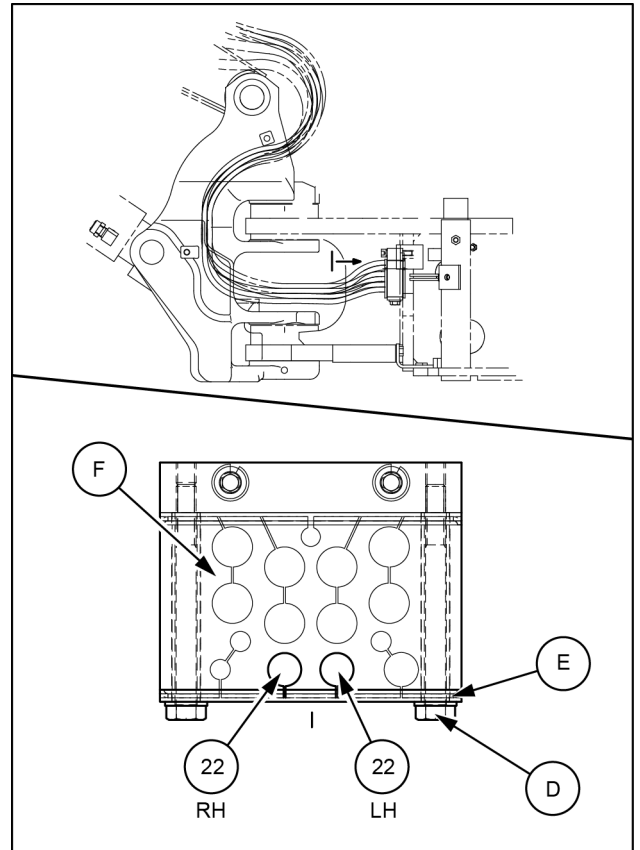

SMIL13MEX0490BB 7

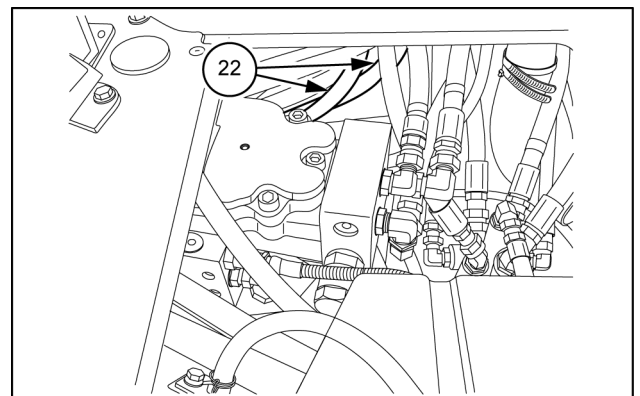

SMIL13MEX0404AB 8

10. Conecte las dos mangueras **(22)** a los puertos D y F de la válvula de conmutación **(14)** sin apretar.
La manguera **(22)** conectada al puerto D llega hasta el lado izquierdo de la pluma.
La manguera **(22)** conectada al puerto F llega hasta el lado derecho de la pluma.

- Llave: **22 mm**

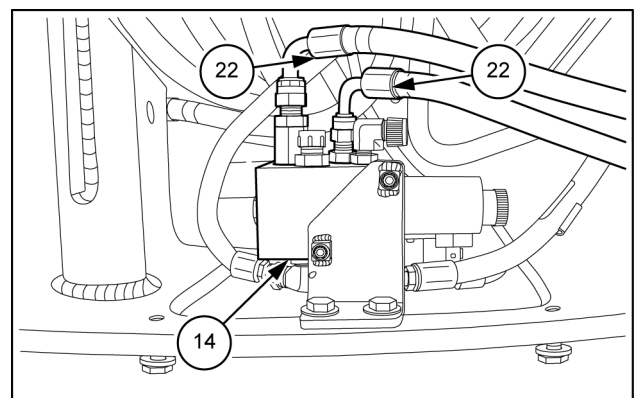

SMIL13MEX0405AB 9

8. Levante la funda de goma (I) de la palanca de control izquierda.
9. Desmonte la cubierta (J) desde la cubierta (K) en la palanca de control izquierda.

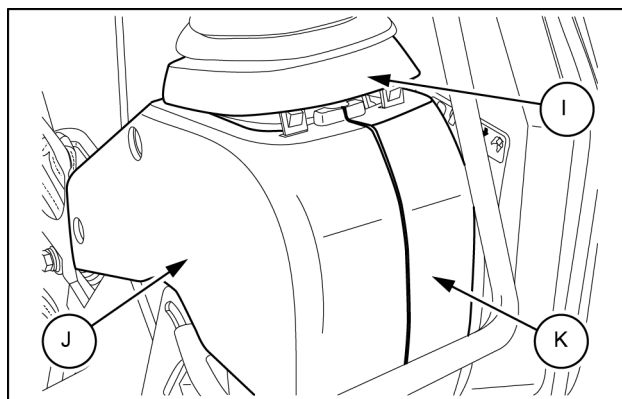

SMIL13MEX0427AB 5

10. Limpie la cubierta (34) y coloque la etiqueta (27).
11. Instale el interruptor del selector (31) en la cubierta (34).
12. Conecte el mazo de cables (32) al interruptor del selector (31).

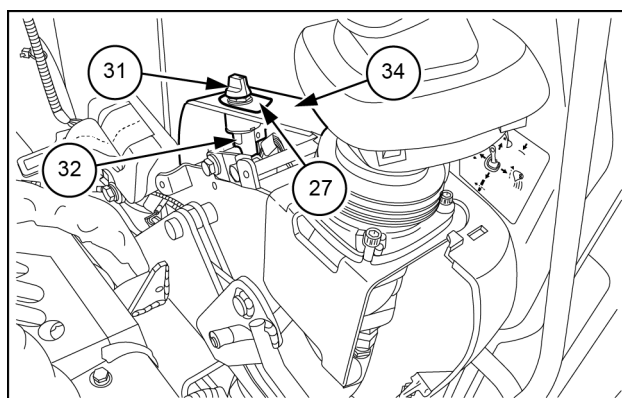

SMIL13MEX0428AB 6

13. Conecte el mazo de cables (32) al conector etiquetado como **CN-42** del mazo de cables principal, deslizándolo por el manguito de goma (L).
14. Apriete el mazo de cables (32) con cables de brida (33) y coloque el mazo de cables debajo de la consola derecha.

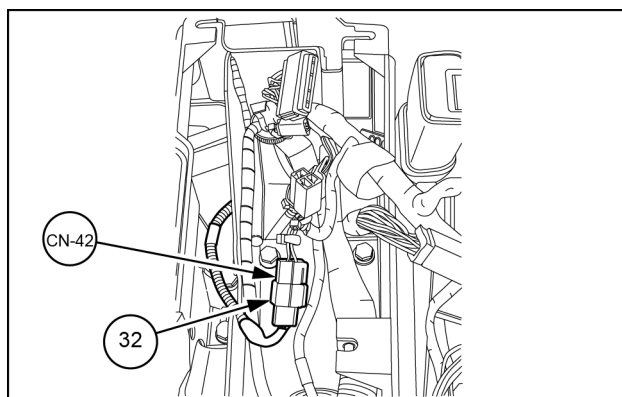

SMIL13MEX0429AB 7

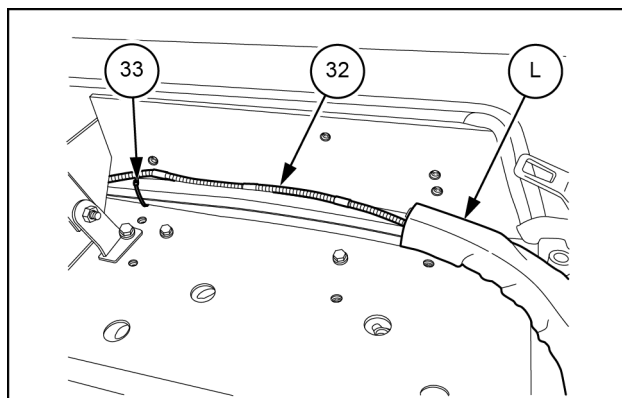

SMIL13MEX0430AB 8

CLICK HERE TO **DOWNLOAD** THE COMPLETE MANUAL

- Thank you very much for reading the preview of the manual.
- You can download the complete manual from: www.heydownloads.com by clicking the link below



- Please note: If there is no response to CLICKING the link, please download this PDF first and then click on it.

CLICK HERE TO **DOWNLOAD** THE COMPLETE MANUAL