

CLAAS



**ROLLANT 250
ROLLANT 255
ROLLANT 255 UNIWRAP**

**ANBAUANLEITUNG
MPS-UMRÜSTUNG**

**INSTALLATION INSTRUCTIONS
MPS CONVERSION**

**NOTICE DE MONTAGE
RÉÉQUIPEMENT MPS**

SERVICE & PARTS

CLICK HERE TO **DOWNLOAD** THE COMPLETE MANUAL

- Thank you very much for reading the preview of the manual.
- You can download the complete manual from: www.heydownloads.com by clicking the link below



- Please note: If there is no response to CLICKING the link, please download this PDF first and then click on it.

CLICK HERE TO **DOWNLOAD** THE COMPLETE MANUAL

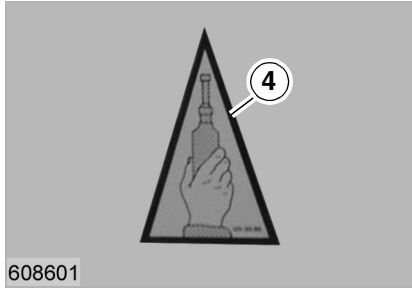
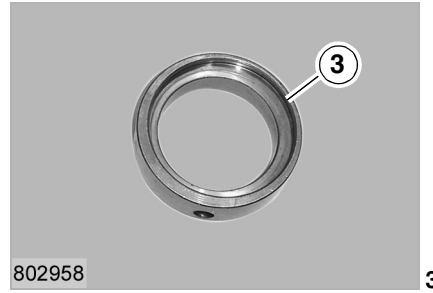
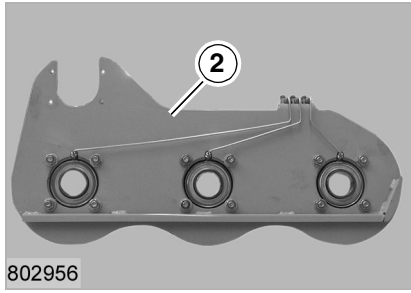
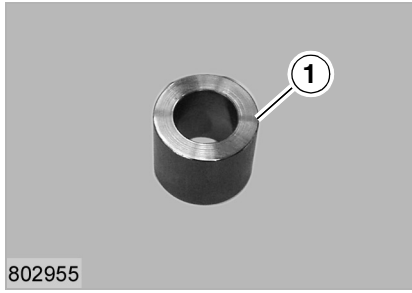

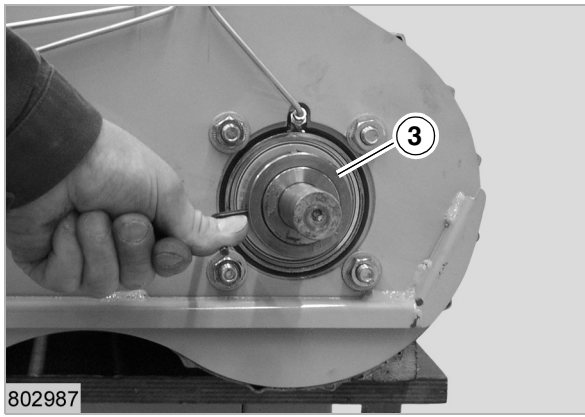

Spannring (3) mit Hilfe der Feststellschraube anziehen.

(Abb. 17)

17

Installation of MPS-conversion set



9

In figure (9), the right hand side of the baler is shown without the MPS-fixing system.

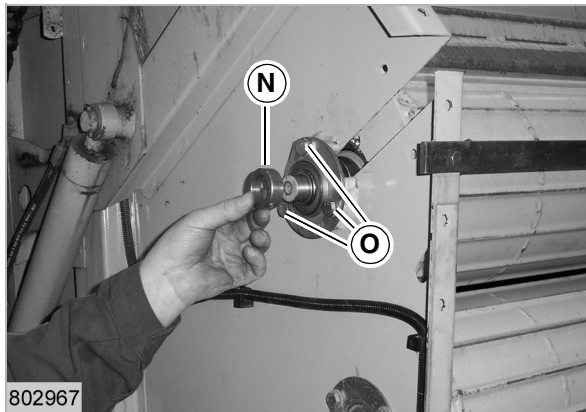

10

Left hand side

Remove clamping ring (N).
Remove the three bolts (O).
(Fig. 10)

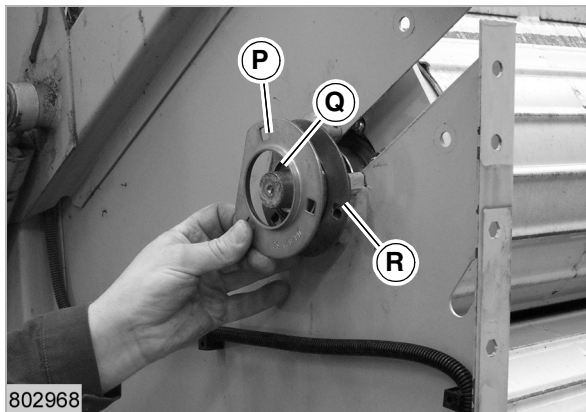

11

Remove the plate bearing (P).
Remove the roller-bearing (Q).
Remove the plate bearing (R).
(Fig. 11)



12

Remove the MPS (S) of the press by using a pulley.
Place the MPS (S) on a solid workplace.
(Fig. 12)

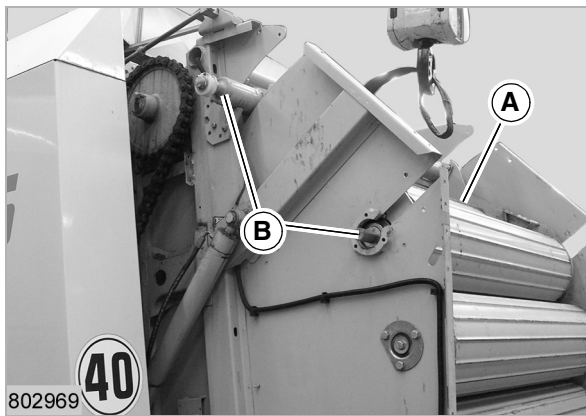

INSTALLING THE MODIFIED MPS

Placing the MPS on the baler

Fasten the modified MPS (A) by using a pulley.
Place the modified MPS on the baler.



Note!

Ensure that the axles (B) on the right and left hand side are positioned correctly.

1

(Fig. 1, 2)

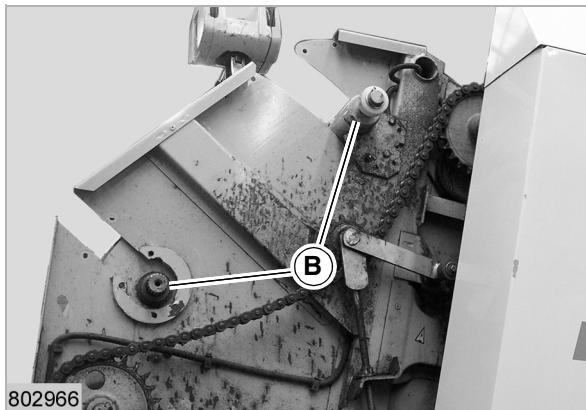

2

Fastening the MPS on the baler

Right hand side

Fasten plate bearing (C) on the axle of roller no. 8.
Hold the plate bearing (C) by using two pins (E).
Slide roller-bearing (D) onto the axle of roller no. 8.
Fasten plate bearing (F) on the axle of roller no. 8.

(Fig. 3)

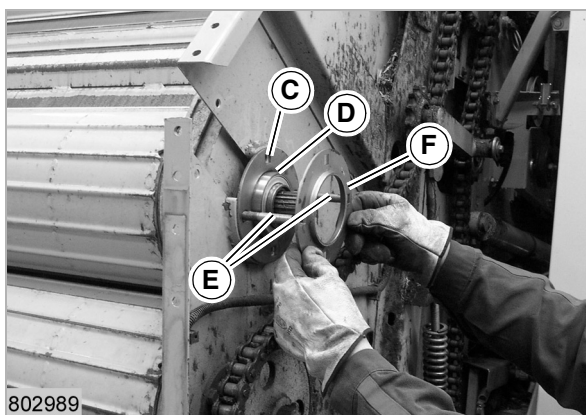

3

Place and tighten the four original bolts (G) to fasten the plate bearings.

Tightening torque: 83.5 Nm

(Fig. 4)

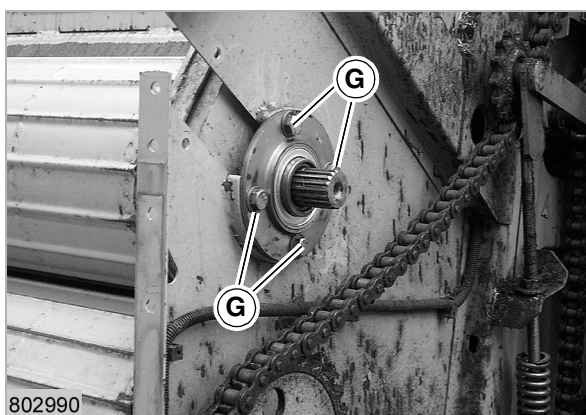

4

Lot de pièces (851 240.0)

Pos. No.	Pièce de rechange	Désignation	Nb
1	851 143.0	Entretoise	3
2	851 239.0	Côté monté	1
3	233 977.1	Bague de serrage E10	3
4	924 112.1	Autocollant	3

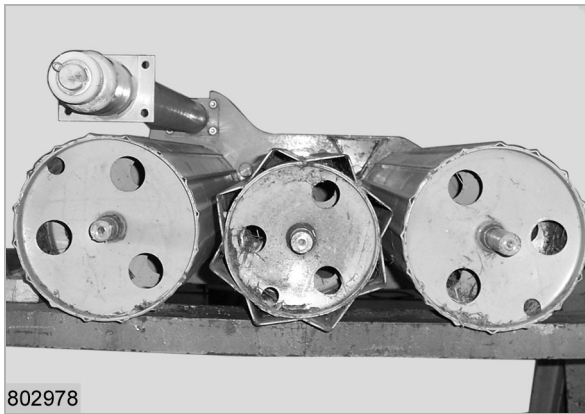

802978

9

Montage du nouveau MPS

La figure (9) présente le MPS sans les tôles anti-pelotage.

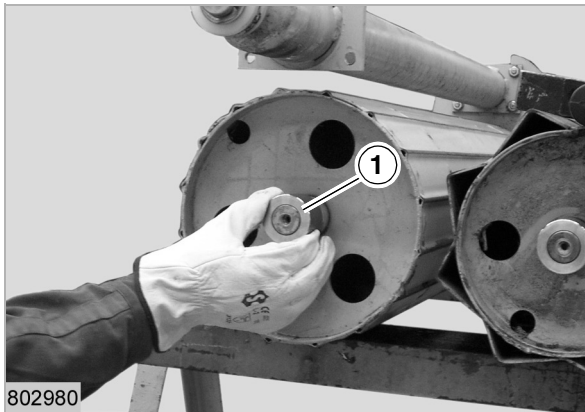

802980

10

Mettre en place l'entretoise (1) à chaud sur chacun des axes de rouleau.



Remarque !

Si nécessaire utiliser un marteau pour permettre le montage serré de l'entretoise.

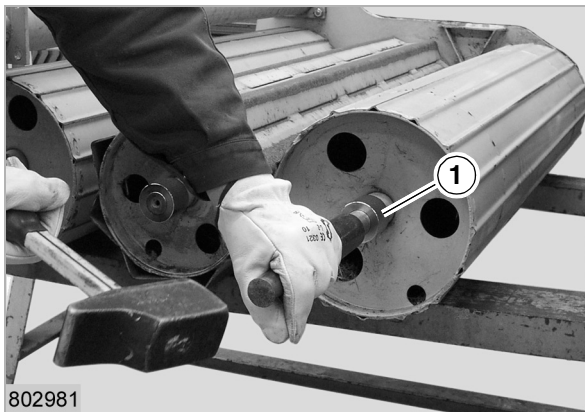

802981

11

(Fig. 10, 11)

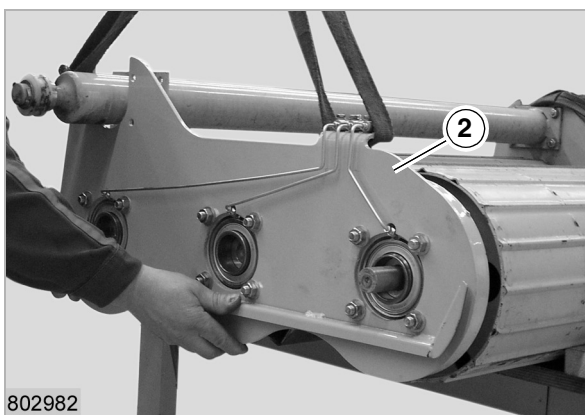

802982

12

Monter le côté monté (2) sur le MPS.

(Fig. 12)

CLICK HERE TO **DOWNLOAD** THE COMPLETE MANUAL

- Thank you very much for reading the preview of the manual.
- You can download the complete manual from: www.heydownloads.com by clicking the link below



- Please note: If there is no response to CLICKING the link, please download this PDF first and then click on it.

CLICK HERE TO **DOWNLOAD** THE COMPLETE MANUAL