



INSTALLATION INSTRUCTIONS

**KG0LP476-00
BREAKER CIRCUIT PEDAL KIT**

APPROXIMATE INSTALLATION TIME: 28.0 hours

CLICK HERE TO **DOWNLOAD** THE COMPLETE MANUAL

- Thank you very much for reading the preview of the manual.
- You can download the complete manual from: www.heydownloads.com by clicking the link below



- Please note: If there is no response to CLICKING the link, please download this PDF first and then click on it.

CLICK HERE TO **DOWNLOAD** THE COMPLETE MANUAL

4 - ASSEMBLY

BREAKER CIRCUIT PEDAL KIT

Boom line installation

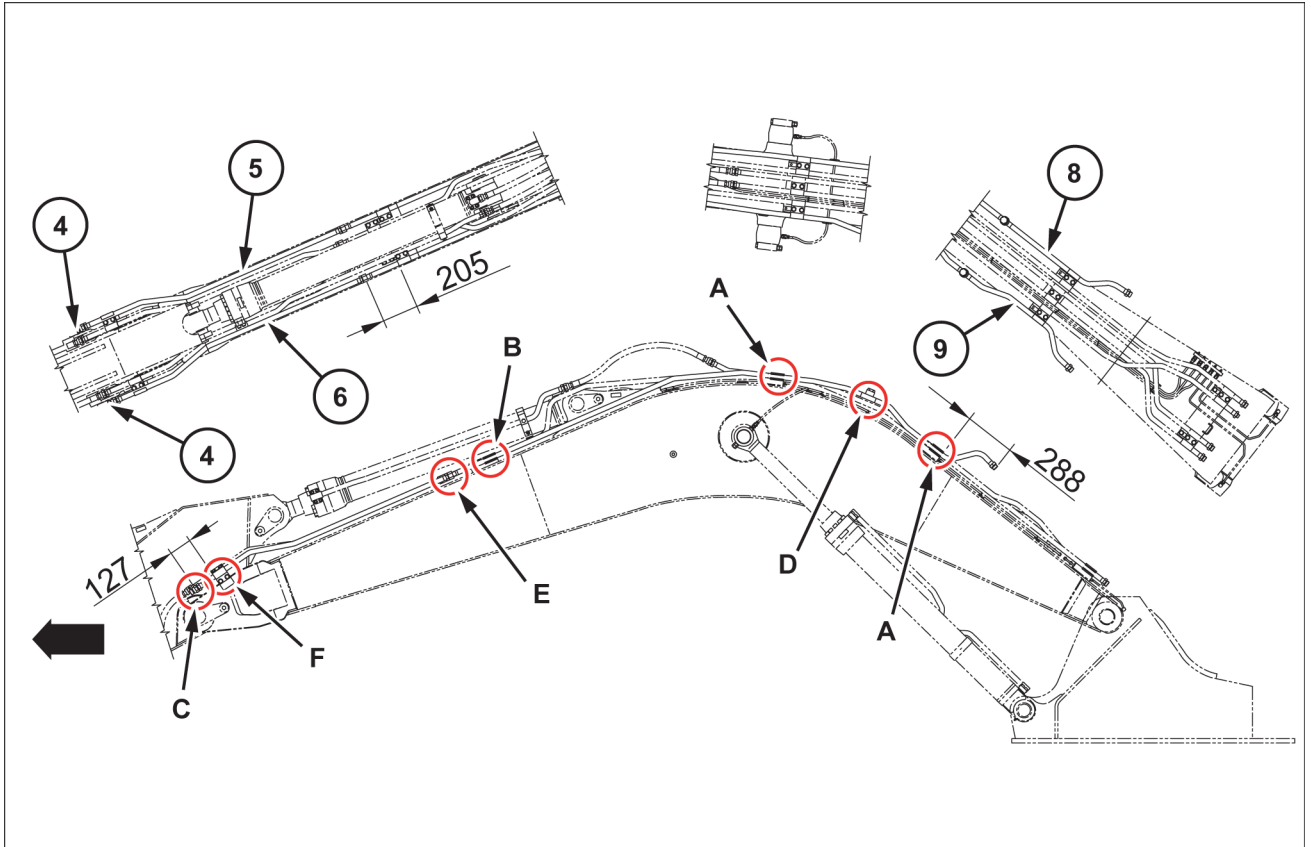

SMIL15CEX8917FB 1

Line Assemblies (8) (9)

1. Set the line assembly (left-hand) (9) on the boom.

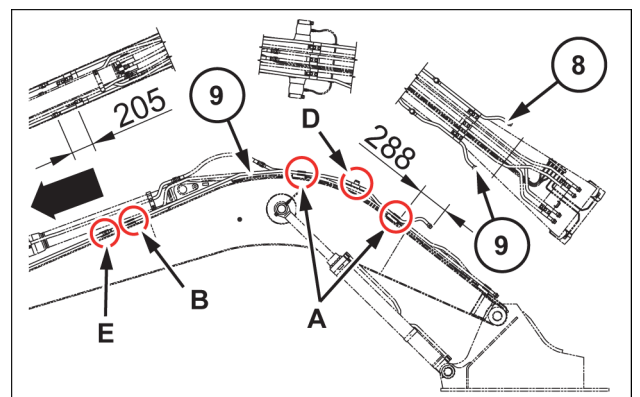

SMIL15CEX8918AB 2

Service valve (remote control valve) installation

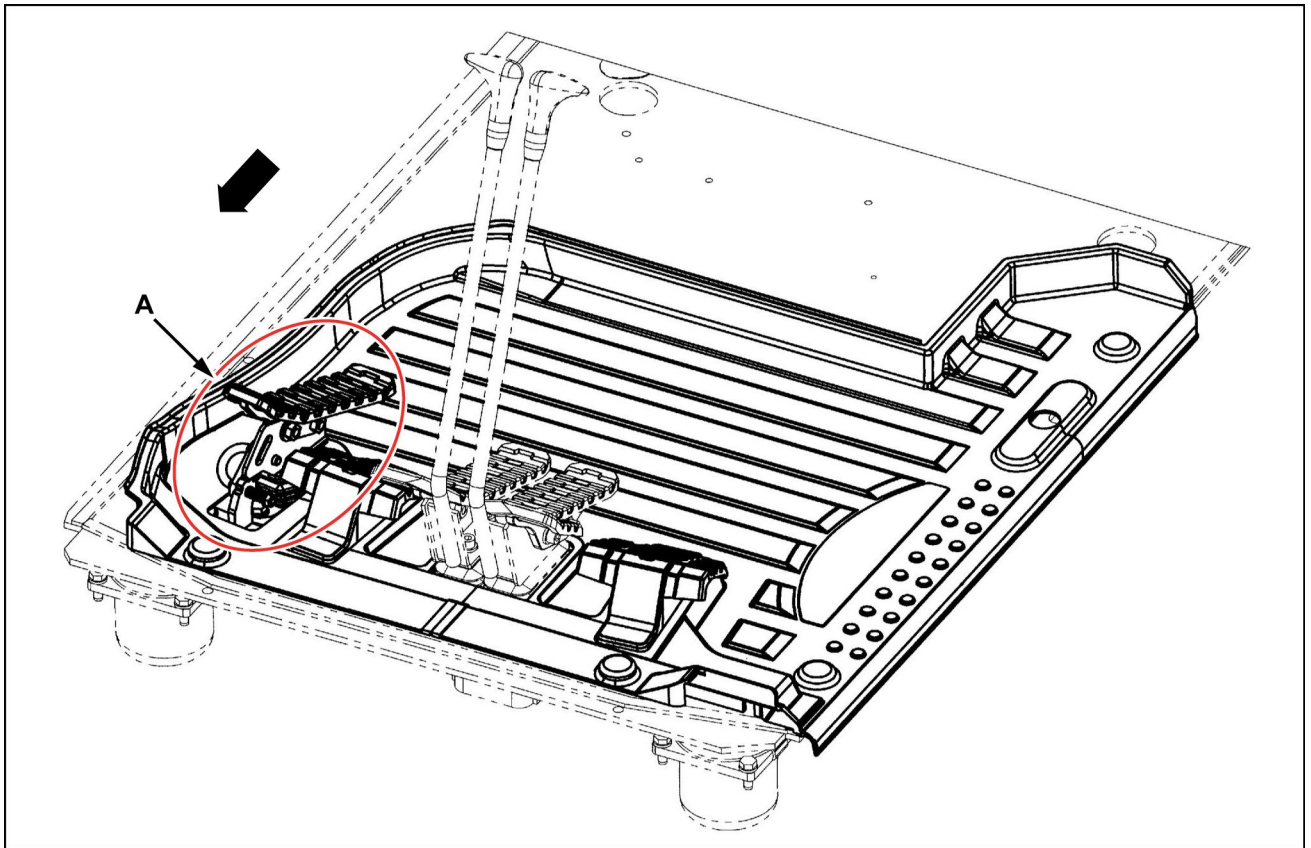

SMIL14II01007FA 1

1. Remove the floor mat from the cab.
2. Install the remote control valve (14) on the front right section of the floor with two sems bolts (13).

Install the option right pedal bracket (16) on the remote control valve (14) with two hexagon socket head bolts (12) and two high-strength washers (11).

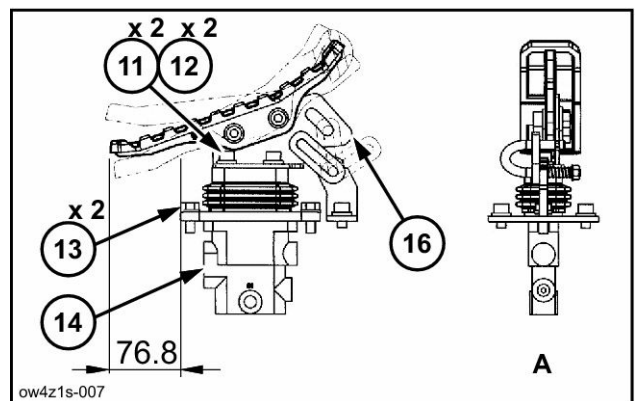

ow4z1s-007

OW4Z1S-007 2

Index

	A	
Additional processing for the floor mat		4-20
	B	
Boom line installation		4-1
	K	
Kit content		2-1
	P	
Preparation		3-1
	S	
Safety rules		1-1
Service valve (remote control valve) installation.		4-11
Service valve (remote control valve) pilot line installation.		4-13
	T	
Tank indicator sensor installation		4-18
	U	
Upper main line installation		4-5

3 - PREENSAMBLADO

PREPARACIÓN PARA MONTAJE

Preparación

En este documento, el símbolo "*" indica que la pieza está montada en la máquina.

Elementos necesarios:

- Llaves (13 mm, 17 mm, 19 mm, 22 mm, 36 mm, 41 mm)
- Llaves fijas (10 mm, 13 mm, 17 mm, 19 mm, 22 mm, 27 mm, 41 mm)
- Llaves hexagonales (8 mm)
- Destornillador Phillips (No. 3)
- Cuchillas, tijeras
- Trapo

1. Coloque la máquina.

- Ponga la máquina en una superficie sólida y nivelada, extienda totalmente el cilindro de la cuchara y el cilindro del brazo, y baje la pluma hasta que la parte superior del brazo toque en el suelo.

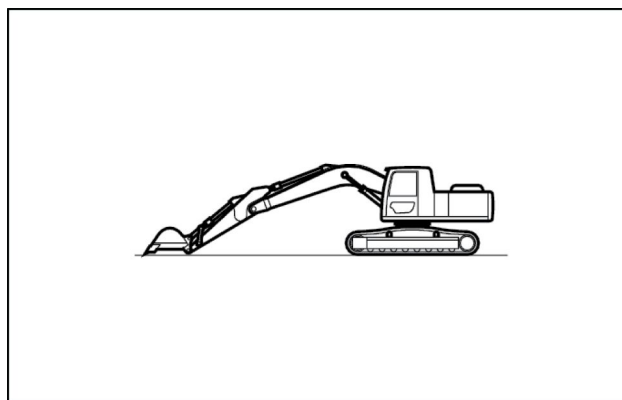

SMIL13II00106AA 1

2. Ponga la llave de contacto (a) en "OFF" (Apagado), asegúrese de que el motor esté parado y ponga de nuevo la llave en "ON" (Encendido). (No arranque el motor)

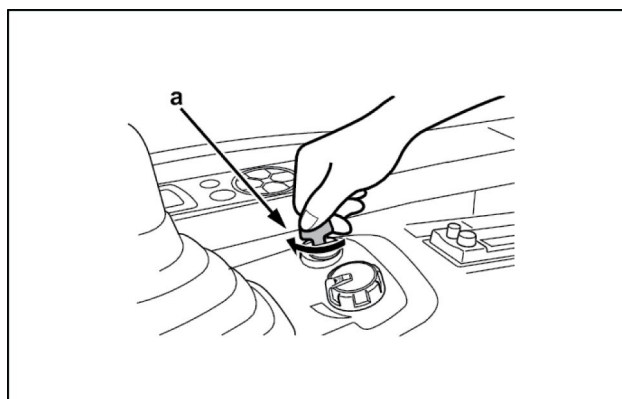

SMIL13II00107AA 2

4. Instale el adaptador para manguera (9) en el colector (8).
 Conecte la manguera hidráulica (10) al adaptador para mangueras (9).

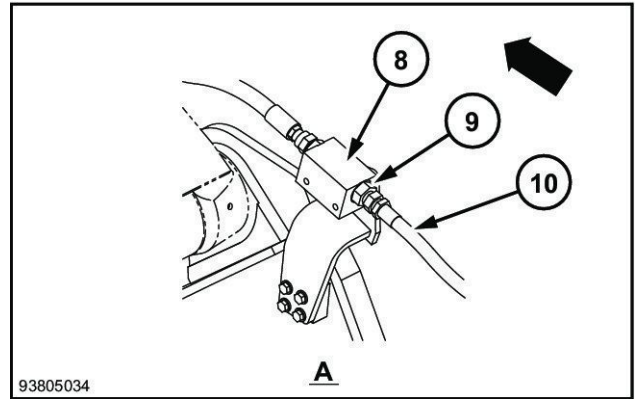

93805034

93805034 10

5. Instale el adaptador para mangueras (11) en el depósito hidráulico (*2).
 Conecte la manguera hidráulica (10) al adaptador para mangueras (11).

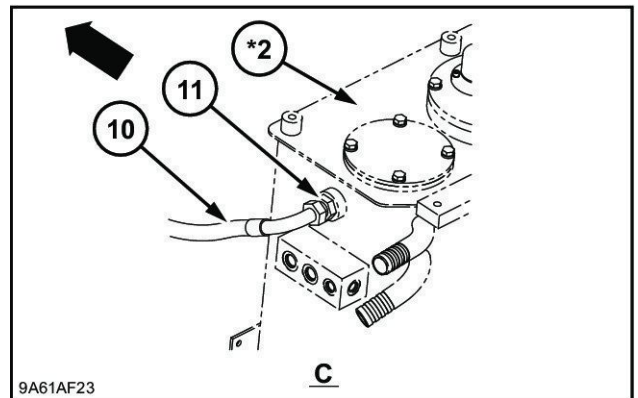

9A61AF23

9A61AF23 11

6. Instale la junta tórica (2) en la manguera hidráulica (1) y conéctela al conjunto del conducto (*4).
- Par de apriete: **157 - 193 N·m (115.797 - 142.349 lb ft)**

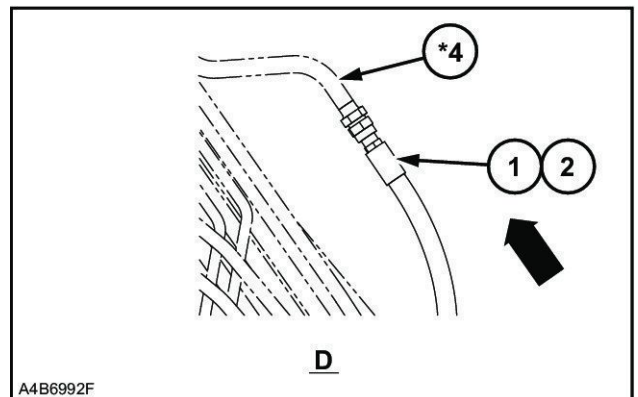

A4B6992F

A4B6992F 12

CLICK HERE TO **DOWNLOAD** THE COMPLETE MANUAL

- Thank you very much for reading the preview of the manual.
- You can download the complete manual from: www.heydownloads.com by clicking the link below



- Please note: If there is no response to CLICKING the link, please download this PDF first and then click on it.

CLICK HERE TO **DOWNLOAD** THE COMPLETE MANUAL