



INSTALLATION INSTRUCTIONS

KG0LP210-00
LOW FLOW HYDRAULIC KIT

APPROXIMATE INSTALLATION TIME: 7 hours

CLICK HERE TO **DOWNLOAD** THE COMPLETE MANUAL

- Thank you very much for reading the preview of the manual.
- You can download the complete manual from: www.heydownloads.com by clicking the link below



- Please note: If there is no response to CLICKING the link, please download this PDF first and then click on it.

CLICK HERE TO **DOWNLOAD** THE COMPLETE MANUAL

7. Sandwich the line assembly (right) **(10)** at 2 locations with 1 pipe clamp **(8)** and 1 pipe clamp **(9)** at each location, and then fasten with 3 sems bolts **(7)** at each location.

For 1 of the pipe clamp **(8)** **(9)** locations, fasten the pipe clamp at a position **115 mm (4.53 in)** from the end of the line assembly (right) **(10)**.

Put the pipe clamp **(9)** on the outside.

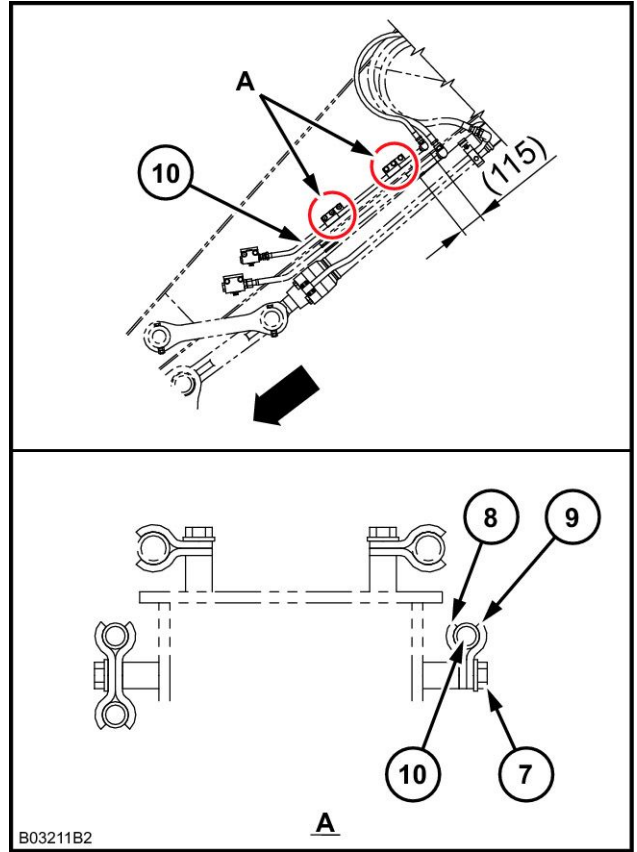

B03211B2

B03211B2 6

8. Connect the line assembly (right) **(10)** and line assembly (right) **(*3)** with the hydraulic hose **(11)**.

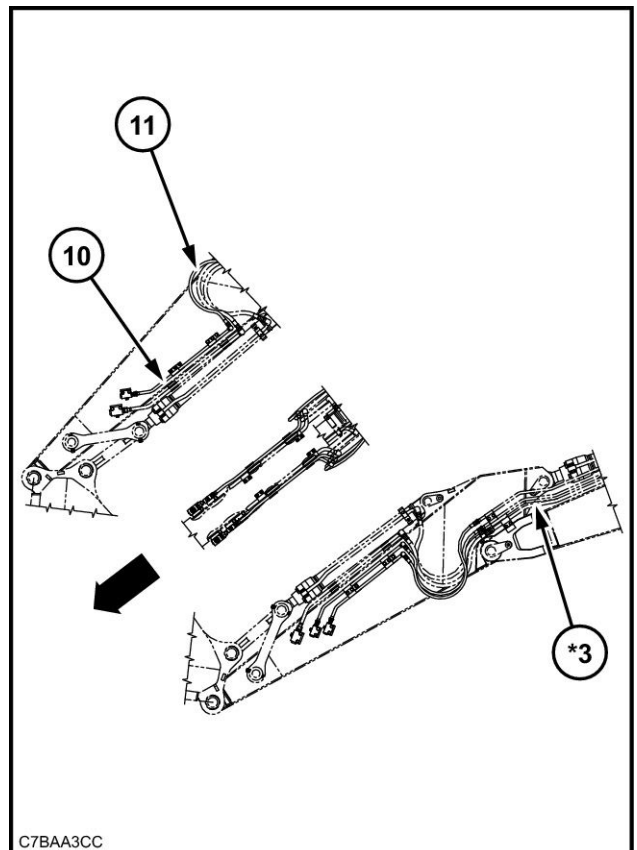

C7BAA3CC

C7BAA3CC 7

Deuxième conduite en option - Conduite de bras standard

CX160C WE, CX180C WE

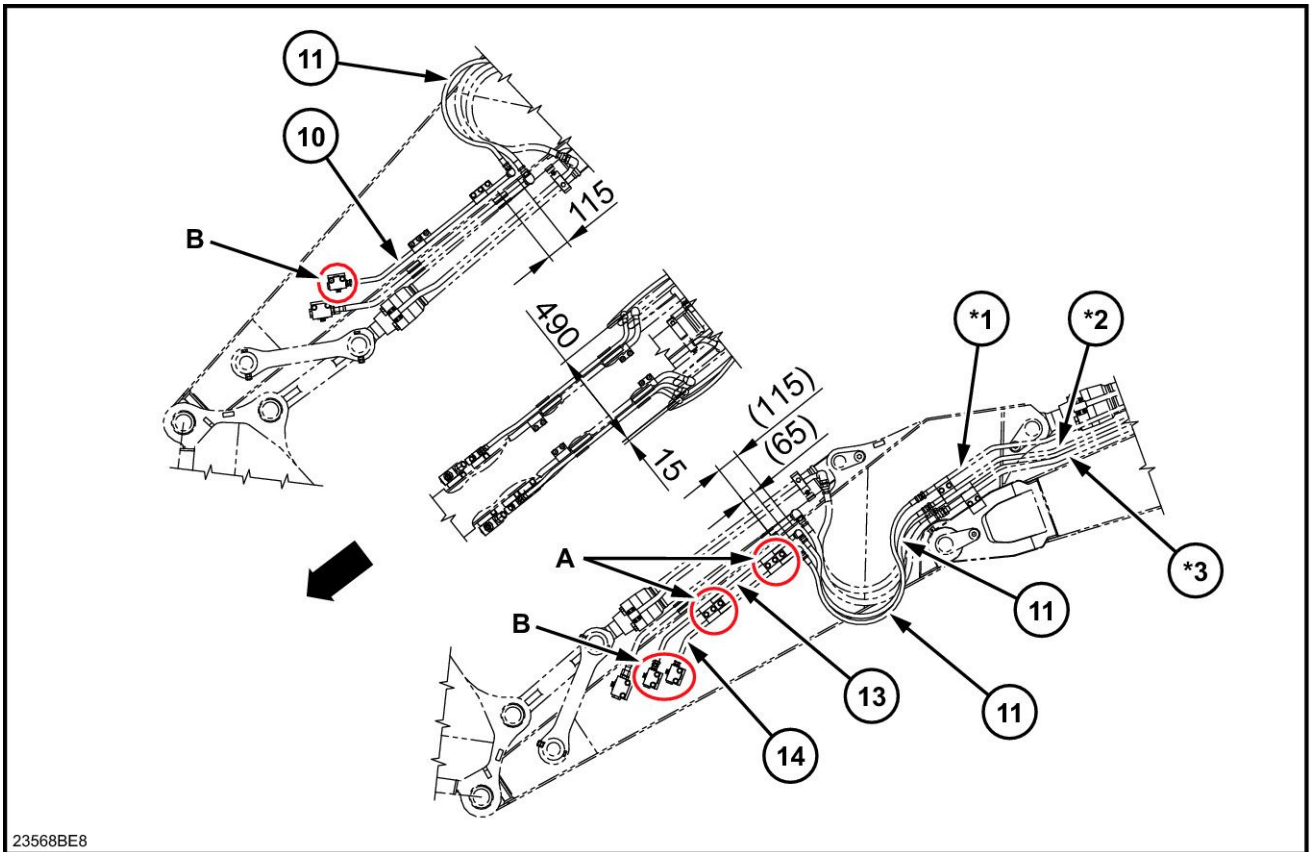

23568BE8

23568BE8 1

1. Utilisez un appareil de levage etc., pour régler l'ensemble conduite (gauche) (13) et l'ensemble conduite (vidange) (14) sur le côté gauche du bras.
2. Posez les 2 vannes d'arrêt (2) au moyen des 2 vis à rondelle (4) situées sur le côté gauche du bras.
Posez un bouchon (1) sur chacune des 2 vannes d'arrêt (2).
Posez un adaptateur de flexible (3) sur chacune des 2 vannes d'arrêt (2).
Connectez l'ensemble conduite (gauche) (13) et l'ensemble conduite (vidange) (14) à 1 adaptateur de flexible (3).

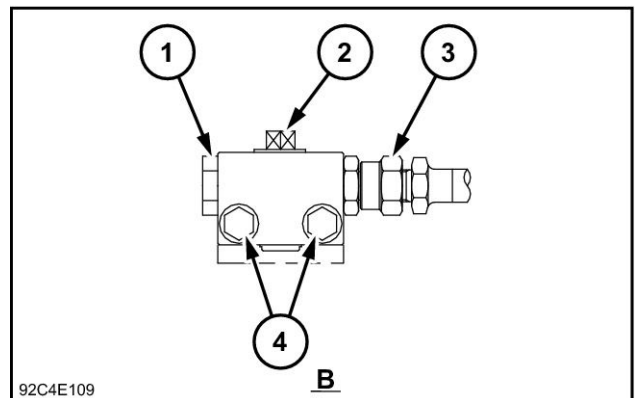

92C4E109

92C4E109 2

3 - MONTAGE

Leitung für 2. Option - Standardarmleitung

Standardarmsitz

CX160C WE, CX180C WE

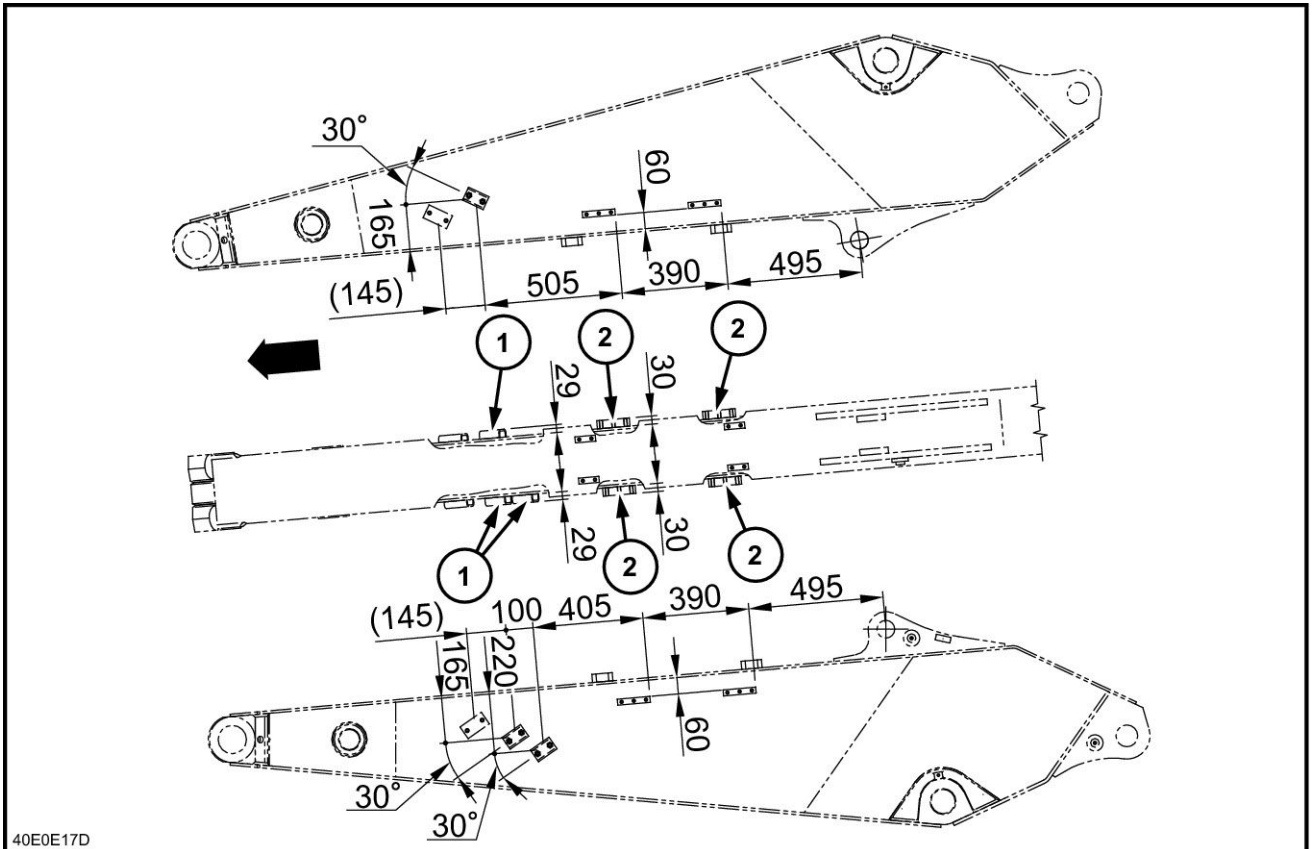

40E0E17D

40E0E17D 1

1. Montieren Sie die 3 Sitze (1) am Arm.
 - Dichten Sie die mit „a“ gekennzeichneten Stellen ab.
 - Schweißen Sie nicht über die mit „b“ (beide Seiten) gekennzeichneten Bereiche.

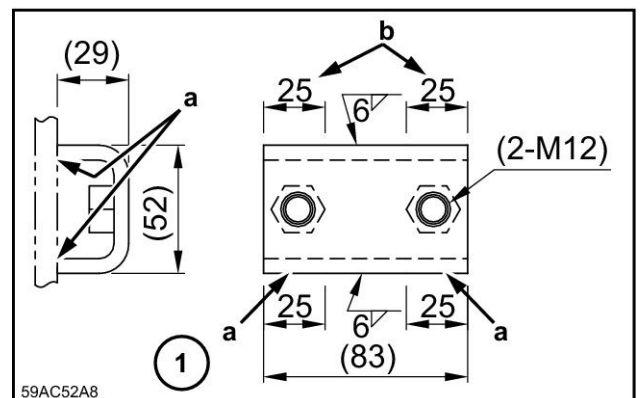

59AC52A8

59AC52A8 2

2 - PREENSAMBLADO

PREPARACIÓN PARA MONTAJE

Preparación

CX160C WE, CX180C WE

En este documento, el símbolo “*” indica que la pieza está montada en la máquina

Elementos necesarios

- Llaves (**19 mm (0.7 in)** y **27 mm (1.1 in)**)
- Grúa
- Equipo de soldadura
- Trapo

1. Coloque la máquina.

- Ponga la máquina en una superficie sólida y nivelada, extienda totalmente el cilindro de la cuchara y el cilindro del brazo, y baje la pluma hasta que la parte superior del brazo toque en el suelo.

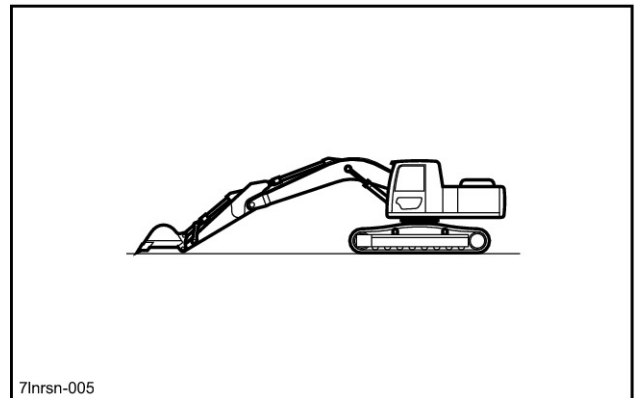

7LNRSN-005 1

2. Ponga la llave de contacto (**a**) en OFF, asegúrese de que se ha detenido el motor y ponga de nuevo la llave en ON. (No arranque el motor).

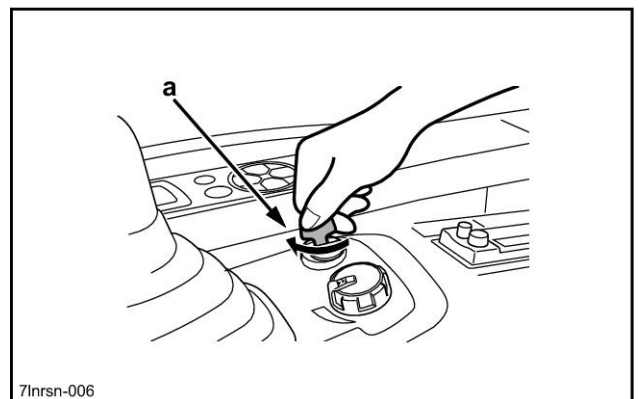

7LNRSN-006 2

Contenuto

1 CONTENUTO DEL KIT	
Contenuto del kit	1-4
2 PRE-ASSEMBLAGGIO	
OPERAZIONI PRELIMINARI PER IL MONTAGGIO	
Preparazione	2-5
3 MONTAGGIO	
Linea 2a opzione - Tubazione del braccio standard	
Sede del braccio standard.....	3-7
Linea 2a opzione - Tubazione del braccio standard.....	3-9

CLICK HERE TO **DOWNLOAD** THE COMPLETE MANUAL

- Thank you very much for reading the preview of the manual.
- You can download the complete manual from: www.heydownloads.com by clicking the link below



- Please note: If there is no response to CLICKING the link, please download this PDF first and then click on it.

CLICK HERE TO **DOWNLOAD** THE COMPLETE MANUAL