



INSTALLATION INSTRUCTIONS

KG1BP512-00
BREAKER CIRCUIT PROPORTIONAL CONTROL KIT

APPROXIMATE INSTALLATION TIME: 28.0 hours

CLICK HERE TO **DOWNLOAD** THE COMPLETE MANUAL

- Thank you very much for reading the preview of the manual.
- You can download the complete manual from: www.heydownloads.com by clicking the link below



- Please note: If there is no response to CLICKING the link, please download this PDF first and then click on it.

CLICK HERE TO **DOWNLOAD** THE COMPLETE MANUAL

Line assemblies (83) and (89)

1. Set the line assembly (left) (83).

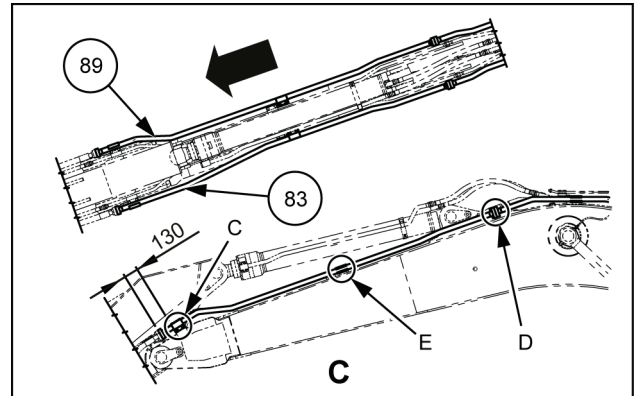

SMIL14CEX5785AB 5

2. Fasten the line assembly (left) (83) with 1 pipe clamp (80) and 2 sems bolts (*1).

- Fasten the pipe clamp (80) at a position 130 mm from the front end of the line assembly (left) (83).

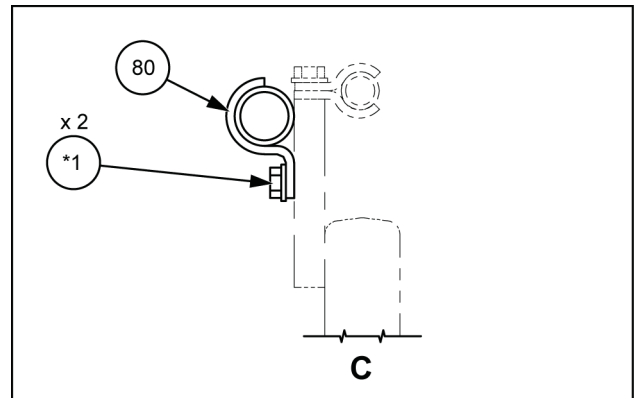

SMIL14CEX5786AB 6

3. Set the O-ring (85) on the end of the line assembly (left) (83), and then connect the line assembly (left) (83) with the 2 split flanges (86) and the 4 hexagon socket head bolts (87).

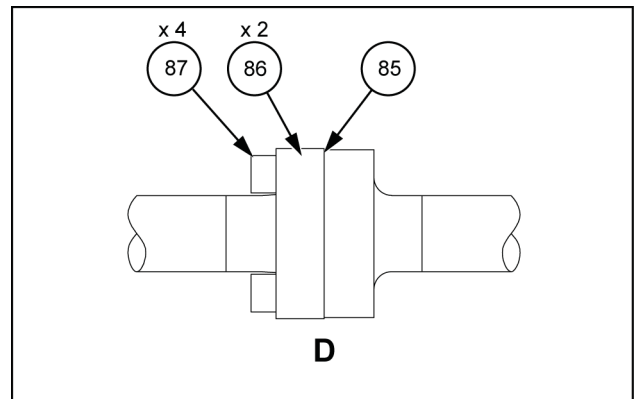

SMIL14CEX5787AB 7

4. Fasten the line assembly (left) (83) with 2 pipe clamp (79) and 81 sems bolt (2).

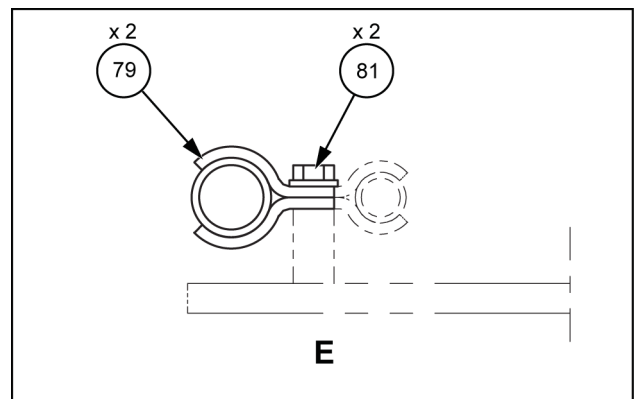

SMIL14CEX5788AB 8

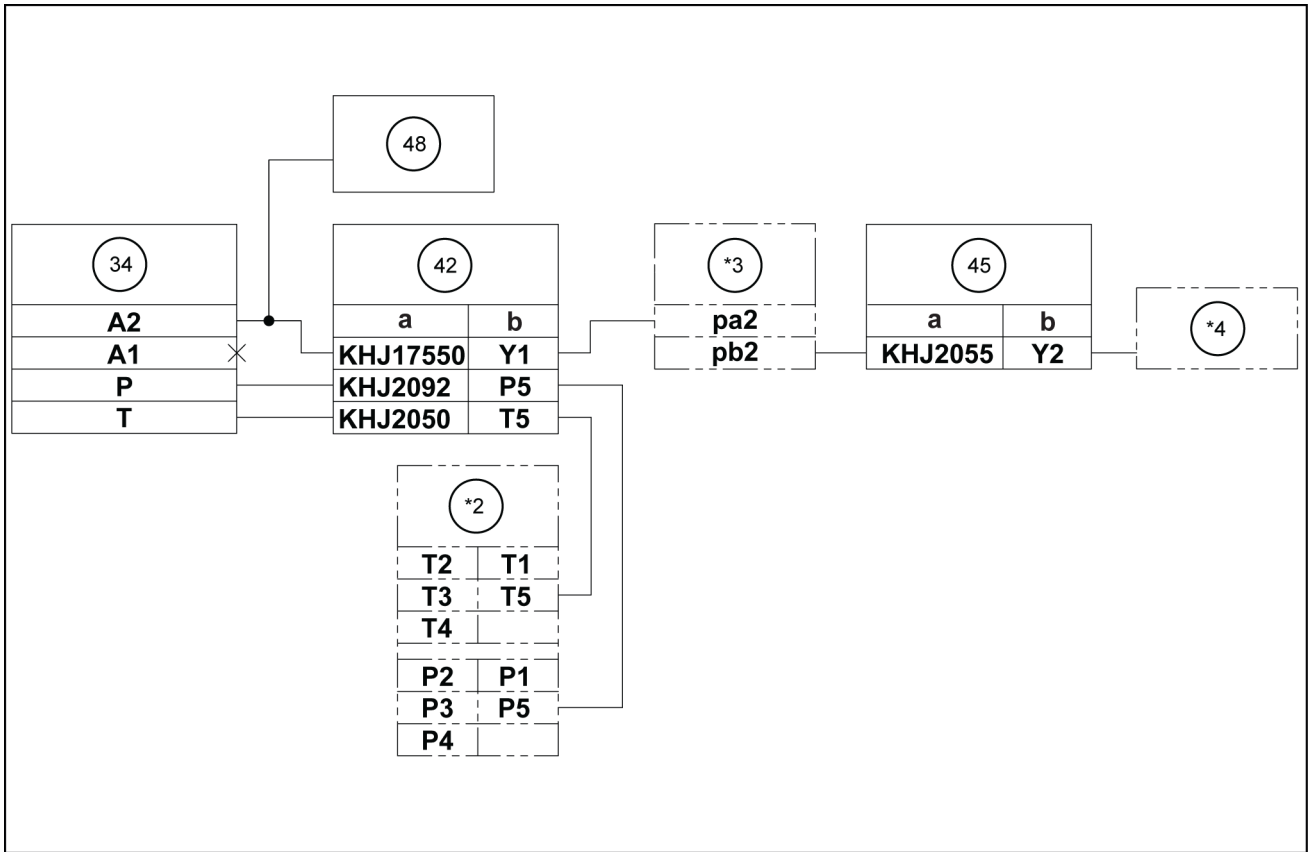

SMIL14CEX5804FB 3

- a. Hose assembly
- b. Code
- *1. Floor

- *2. Manifold
- *3. Control valve
- *4. Hydraulic tank

2. Install the horn switch connector (*11), bundle with the wire band (*12), and then cover the control lever boot (*10).

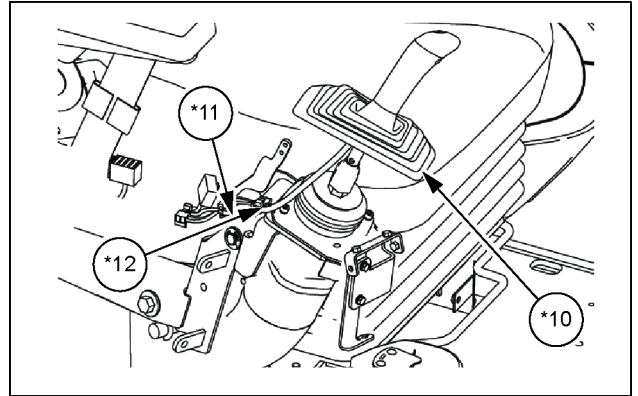

SMIL14II00174AB 9

3. Use a Phillips screwdriver or box wrench 10 mm to install the cover (*9) with 5 bolts (*8).

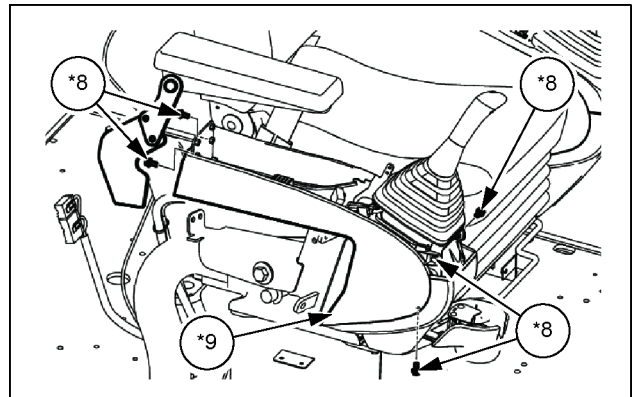

SMIL14II00175AB 10

4. Install the connectors (*6) and install the console top cover (*7).

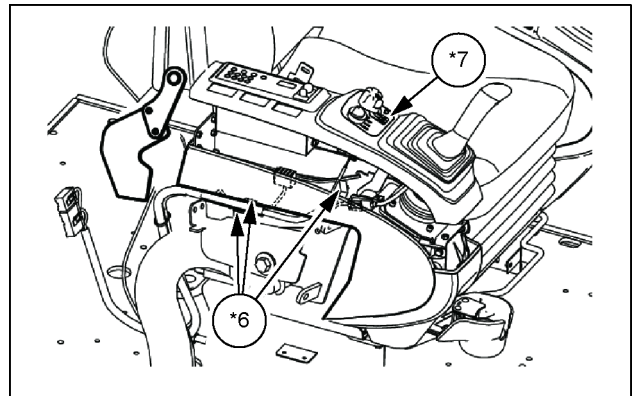

SMIL14II00176AB 11

5. Use the Phillips screwdriver to install the 2 screws (*5) of the console top cover.

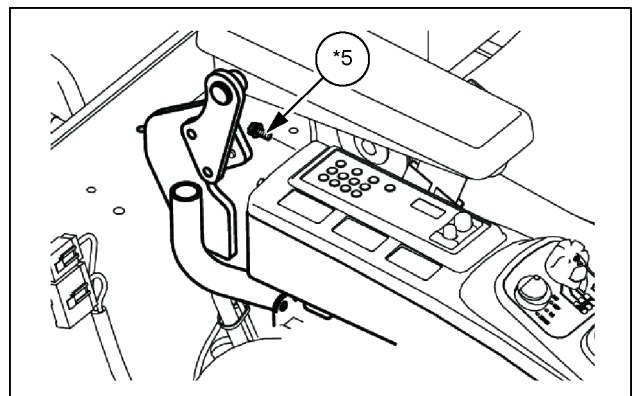

SMIL14II00177AB 12

Inhalt

1 SATZINHALT	
Satzinhalt	1-1
2 VORMONTAGE	
VORBEREITUNG ZUR MONTAGE	
Vorbereitung	2-1
3 MONTAGE	
MONTAGESATZ BRECHERKREIS-PROPORTIONALSTEUERUNG	
Einbau der Auslegerleitung	3-1
Einbau der oberen Hauptleitung	3-5
Montage der Vorsteuerleitung - Proportionalsteuerung	3-12
Kabelbaummontage - Proportionalsteuerung	3-17
Montage des Steuerhebels	3-21
Einbau des Behälteranzeigesensors (Filterverstopfungswarnung)	3-25
Montage des Typenschilds in der Kabine	3-27

Einbau der oberen Hauptleitung

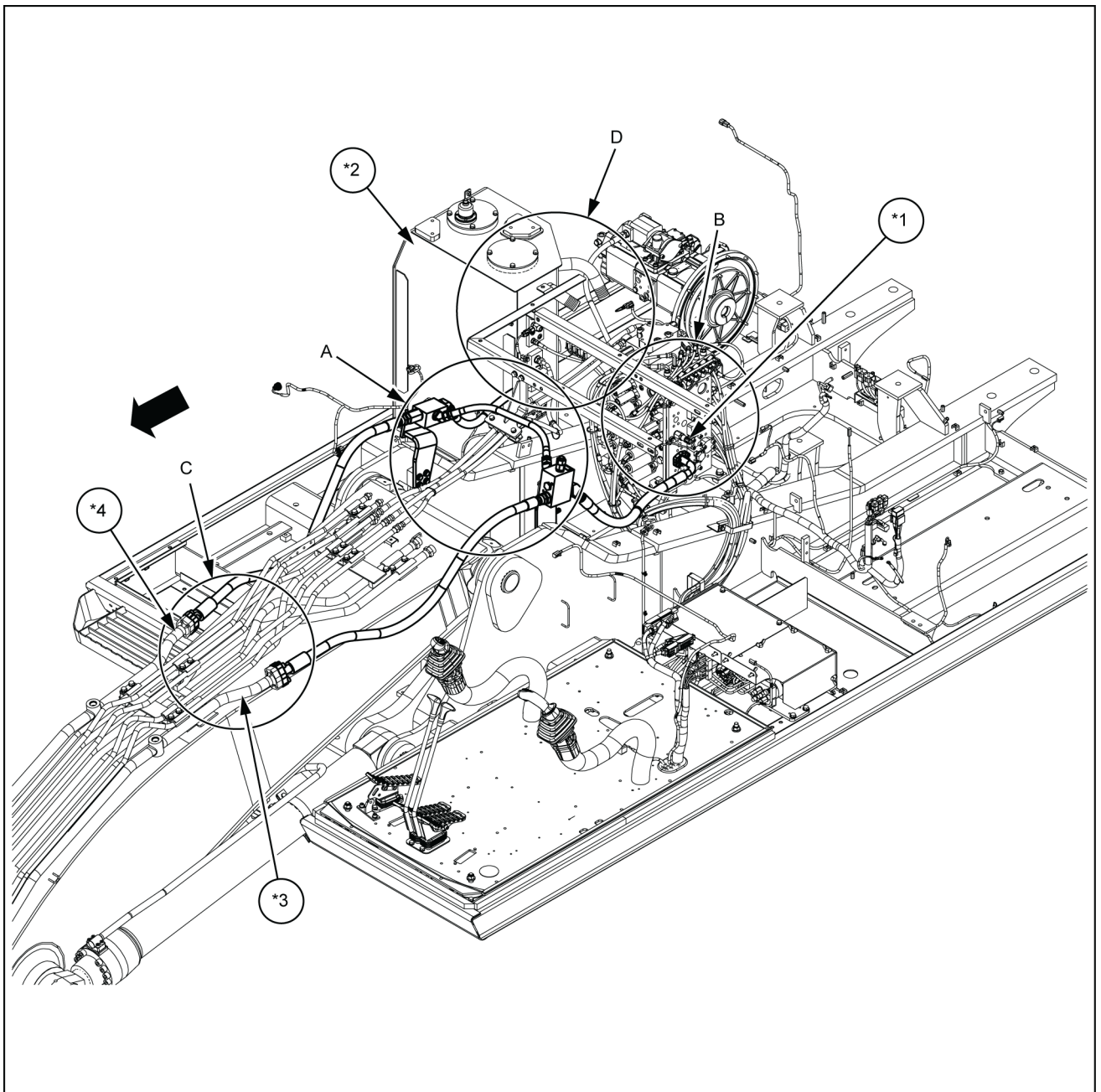

SMIL14CEX5790GB 1

6. Montieren Sie das Kniestück (50) am P5-Anschluss des Verteilers (*2). Verbinden Sie Anschluss P von Druckminderventil (34) und Anschluss P5 von Verteiler (*2) mit dem Baugruppschlauch (42/P5).

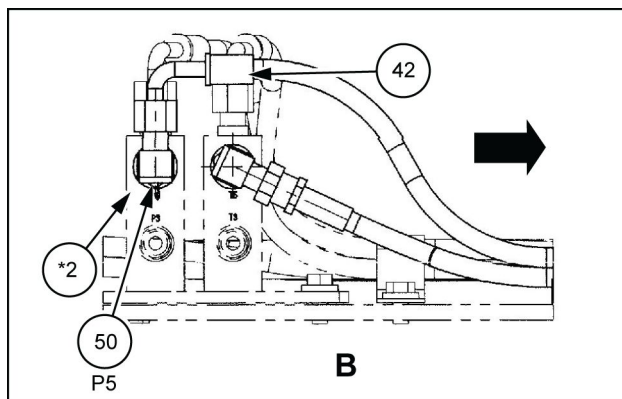

SMIL14CEX5809AB 8

7. Montieren Sie den Verschluss (41) an Anschluss A1 des Druckminderventils (34). Montieren Sie das T-Stück (40) an Anschluss A2 des Druckminderventils (34).

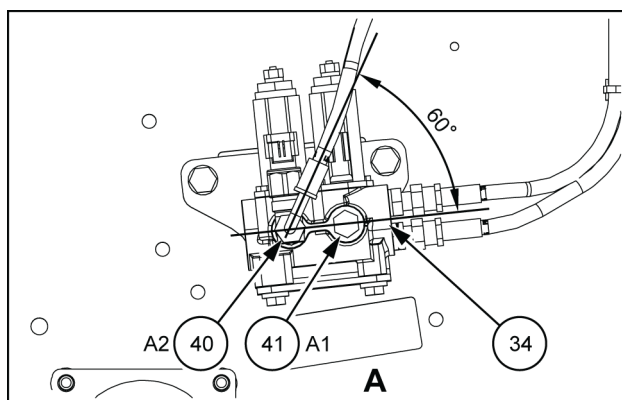

SMIL14CEX5810AB 9

8. Montieren Sie das Kniestück (44) am Anschluss pa2 des Steuerventils (*3). Verbinden Sie Anschluss A2 von Druckminderventil (34) und Anschluss pa2 von Steuerventil (*3) mit dem Baugruppschlauch (42/Y1).

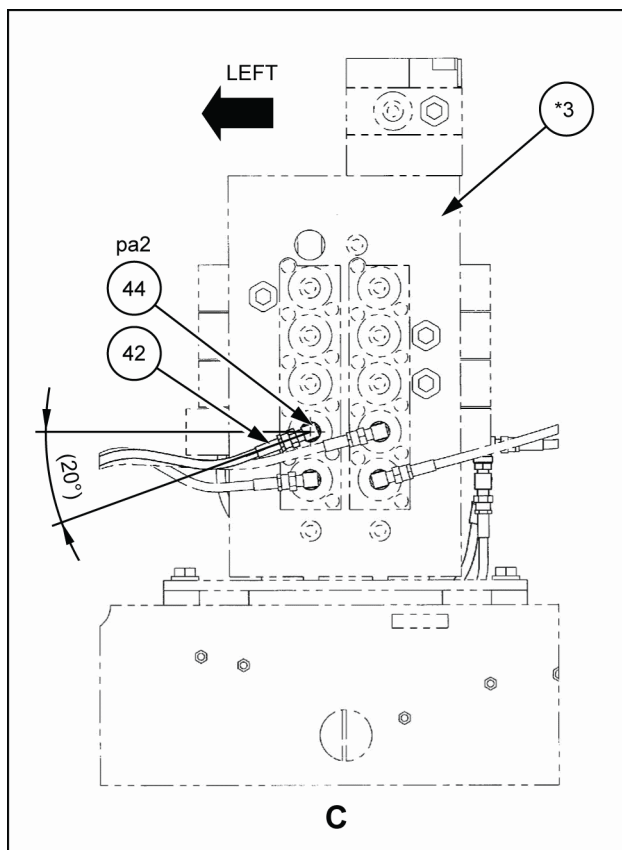

SMIL14CEX5811BB 10

Einbau des Behälteranzeigesensors (Filterverstopfungswarnung)

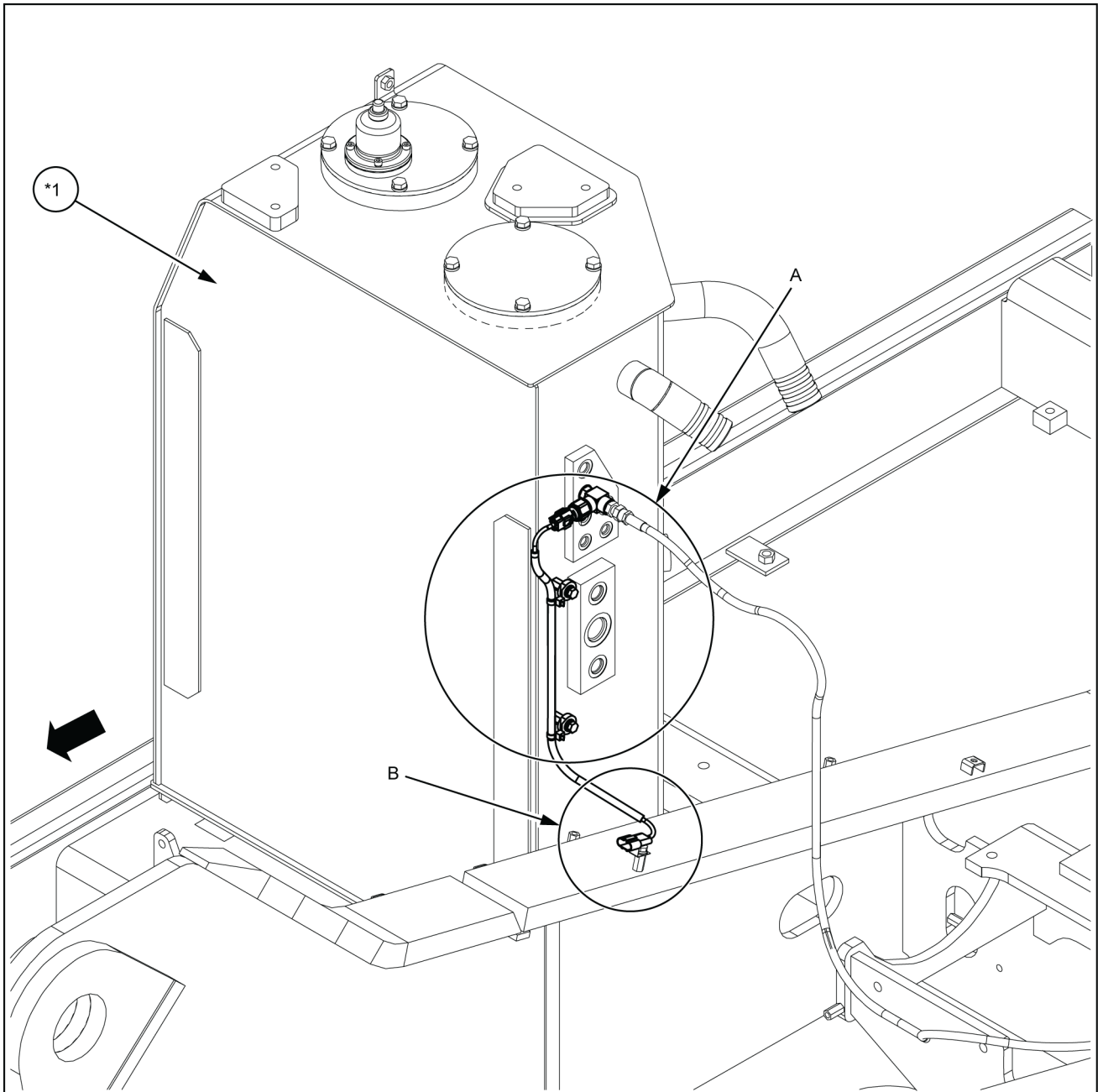

SMIL14CEX5814GB 1

1. Montieren Sie das T-Stück (56) und den Drucksensor (57) am Hydraulikbehälter (*1). Schließen Sie den Sensorkabelstrang (58) an den Drucksensor (57) an. Befestigen Sie den Sensorkabelbaum (58) mit 2 Bandschellen (59) und 2 Spezialschrauben (60).

- Anzugsmoment: **23.5 - 35.3 N·m (17.33 - 26.04 lb ft)**

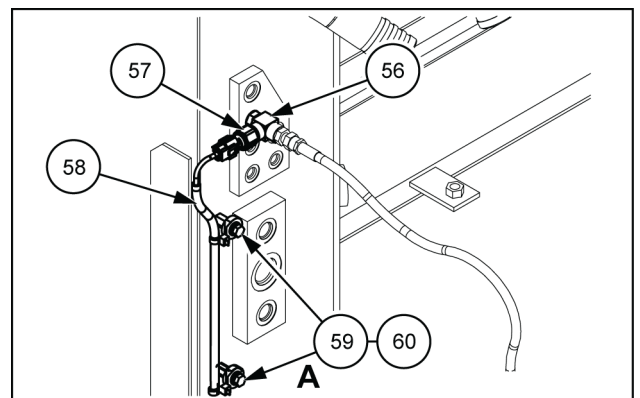

SMIL14CEX5815AB 2

1 - CONTENU DU KIT

Contenu du kit

REMARQUE: pour en savoir plus, consulter le manuel de pièces pour les commandes de pièces.

Levier de commande (côté droit) (voir 3-21)

Item	Description	Quantité	Référence de pièce
1	Bouton (droit), commande proportionnelle	1	KHJ28550

Circuit principal marteau (voir 3-5)

Item	Description	Quantité	Référence de pièce
4	Flexible hydraulique	1	KBJ23800
5	Joint torique	1	KHJ0914
6	Bride fendue (G1)	2	KRJ2682
7	Boulon à tête creuse hexagonale (M10 x 30)	4	108R010Y030R
8	Joint torique	3	KHJ1361
9	Raccord coudé	1	KHJ11370
10	Clapet de décharge	1	KHJ15050
11	Support	1	KRJ11470
12	Vis à rondelle (M12 x 30)	12	105R012Y030R
13	Adaptateur de flexible	2	KHJ1349
15	Flexible hydraulique	2	KBJ11790
16	Joint torique	2	M20J0771
17	Bride fendue (G1 x 1/4)	4	KTJ0029
18	Boulon à tête creuse hexagonale (M14 x 50)	8	108R014Y050R
21	Douille	1	KHJ25900
22	Collecteur	1	KRJ16400
23	Support	1	KBJ16300
26	Coude (G3/4)	2	KHJ0351
27	Flexible hydraulique	1	KBJ13790
29	Coude (G1)	1	KHJ0352
30	Flexible hydraulique	1	KBJ19800
31	Coude (G1)	1	KHJ0345

Commande proportionnelle du circuit de pilotage du marteau (voir 3-12)

Item	Description	Quantité	Référence de pièce
34	Soupape de réduction	1	MFJ71500
35	Vis à rondelle (M8 x 16)	2	105R008Y016R
36	Support	1	KHJ28770
37	Vis à rondelle (M10 x 20)	2	105R010Y020R
38	Adaptateur de flexible (G1/4)	2	KNJ0758
39	Graisseur avec filtre (G1/4)	1	CNA0584
40	Raccord en T (G1/4)	1	KAJ3807
41	Obturateur (G1/4)	1	KHJ0363
42	Ensemble flexible	1	KBJ23840
44	Raccord coudé	2	KHJ28690
45	Ensemble flexible	1	KBJ23820
48	Capteur de pression	1	KHR26940
50	Coude (G1/4)	2	KHJ28580
51	Attache de montage	4	KHR0319
52	Vis cruciforme à tête large (M6 x 8)	4	145N006S008R
53	Bracelet (L = 250)	4	KHH0142

CLICK HERE TO **DOWNLOAD** THE COMPLETE MANUAL

- Thank you very much for reading the preview of the manual.
- You can download the complete manual from: www.heydownloads.com by clicking the link below



- Please note: If there is no response to CLICKING the link, please download this PDF first and then click on it.

CLICK HERE TO **DOWNLOAD** THE COMPLETE MANUAL

3. Placer le joint torique (5) sur l'orifice A2 du distributeur (*1), puis connecter le flexible hydraulique (4) à l'aide de 2 brides fendues (6) et de 4 boulons à tête creuse hexagonale (7).

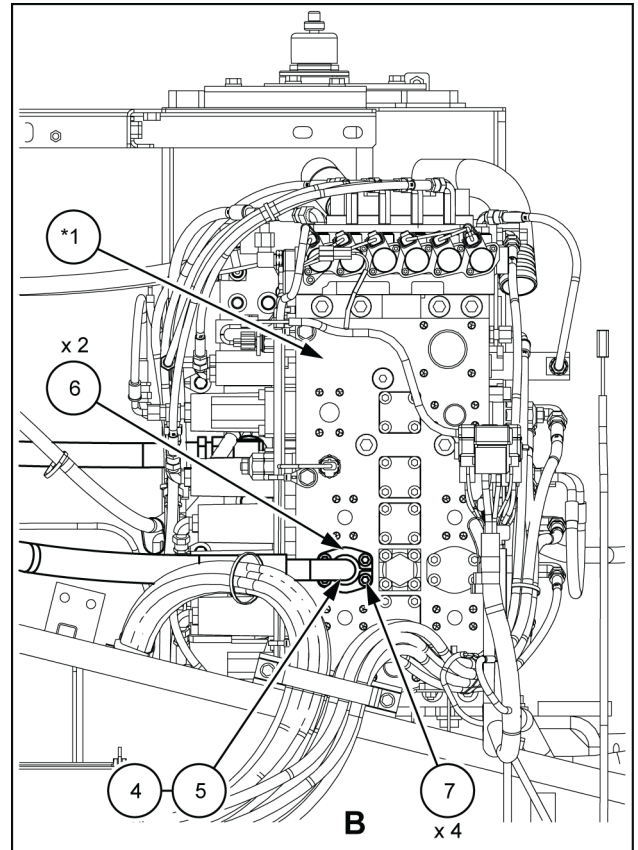

SMIL14CEX5793BB 4

4. Poser l'adaptateur de flexible (13) sur l'orifice B du clapet de décharge (10). Placez le joint torique (8) sur l'adaptateur de flexible (13) et mettez en place le flexible hydraulique (15).

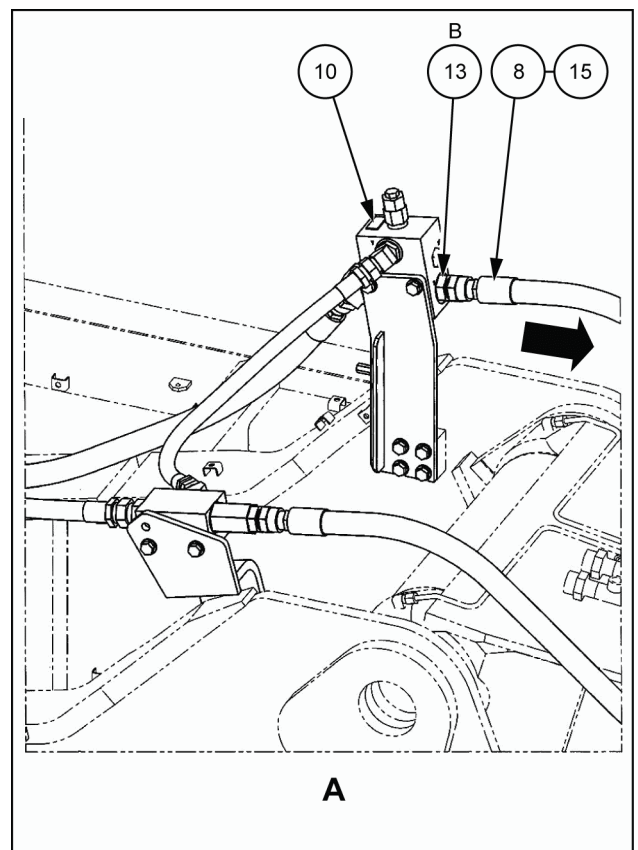

SMIL14CEX5794BB 5

Pose du faisceau - Commande proportionnelle

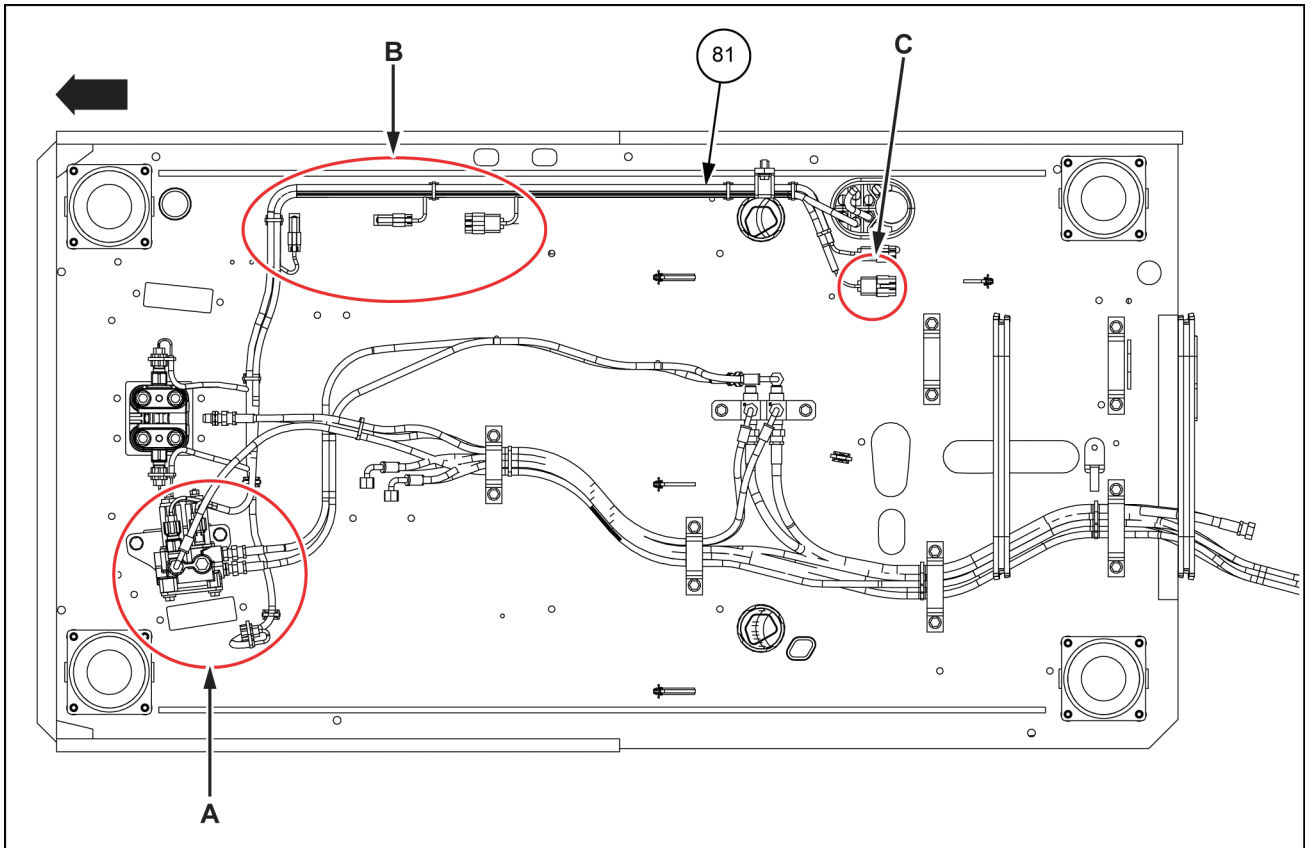

SMIL14II01074FB 1

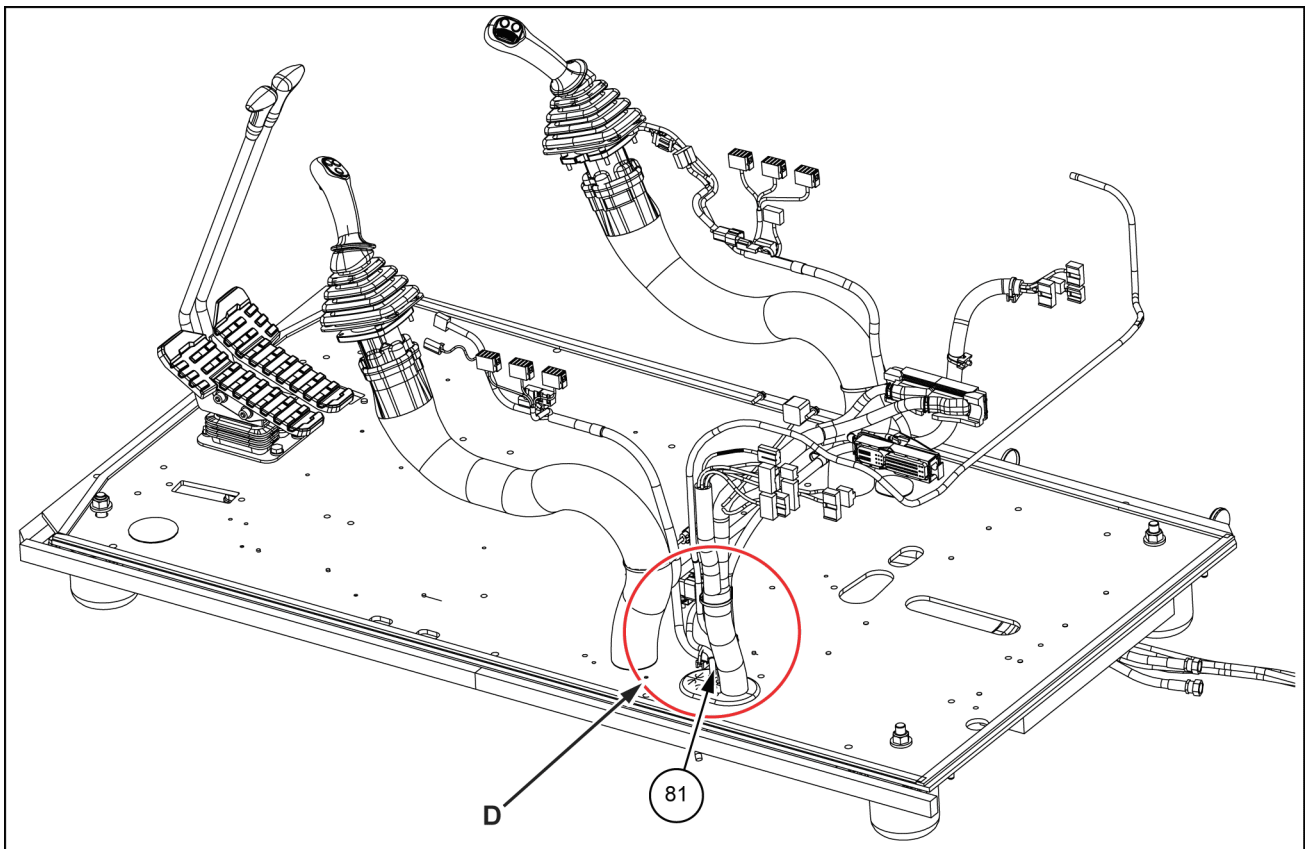

SMIL14II01075FB 2

Installation de la plaque signalétique à l'intérieur de la cabine

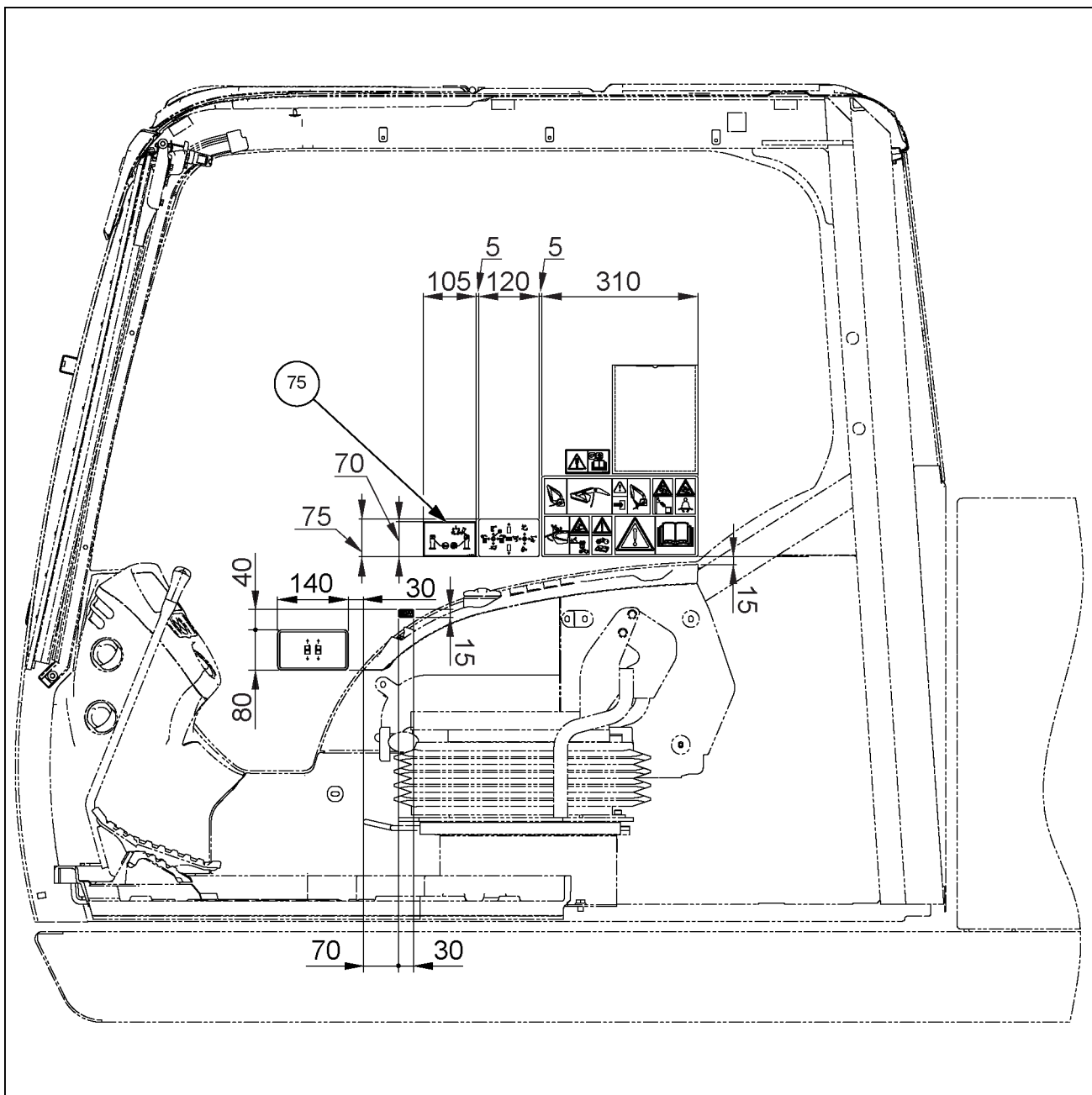

SMIL14II01084GB 1

1. Dépoussiérer l'endroit où l'étiquette doit être posée.
2. Fixer l'étiquette de fonctionnement de la commande au pied (ISO) (75).

2 - PRE-ASSEMBLAGGIO

OPERAZIONI PRELIMINARI PER IL MONTAGGIO

Preparazione

Un simbolo * in questo documento indica che la parte è montata sulla macchina vera e propria.

Componenti da preparare:

- Chiavi (**13 mm**, **17 mm**, **19 mm**, **36 mm**, **41 mm**, **46 mm**, **50 mm**)
- Chiavi esagonali (**8 mm**, **12 mm**)
- Cacciavite Phillips (n. 3)
- Fresa, forbici
- Straccio

1. Posizionare l'unità principale.

- Posizionare l'unità principale su un terreno solido e pianeggiante, mettere il cilindro della benna in posizione di finecorsa aperto, il cilindro del braccio in posizione di finecorsa aperto, abbassare l'avambraccio e toccare terra con la punta del braccio.

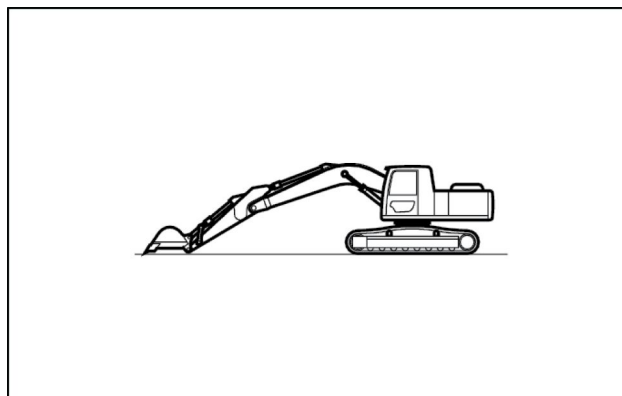

SMIL13II00106AA 1

2. Disinserire la chiave di accensione (a), controllare che il motore si sia arrestato, quindi reinsertare la chiave di accensione. (Non avviare il motore.)

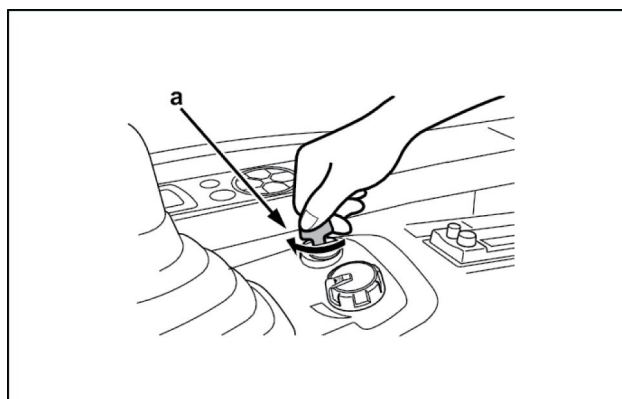

SMIL13II00107AA 2

- Montare il collettore (22) sulla staffa (23) con 2 bulloni tipo Sems (12).

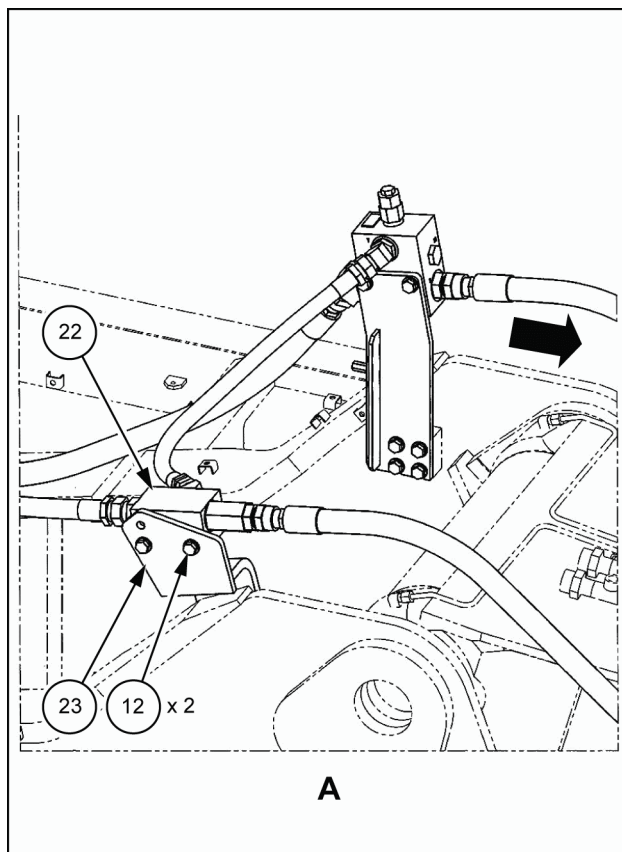

SMIL14CEX5796BB 8

- Montare il gomito (29) sul collettore (22), lato serbatoio idraulico (*2). Collegare il flessibile idraulico (30) al gomito (29).

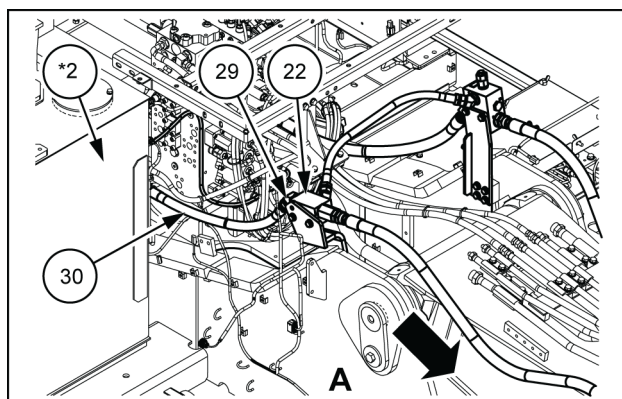

SMIL14CEX5798AB 9

3. Fissare i 3 accoppiatori sul cablaggio (81) con 1 fermo (83) ciascuno e 1 bullone (84) ciascuno.

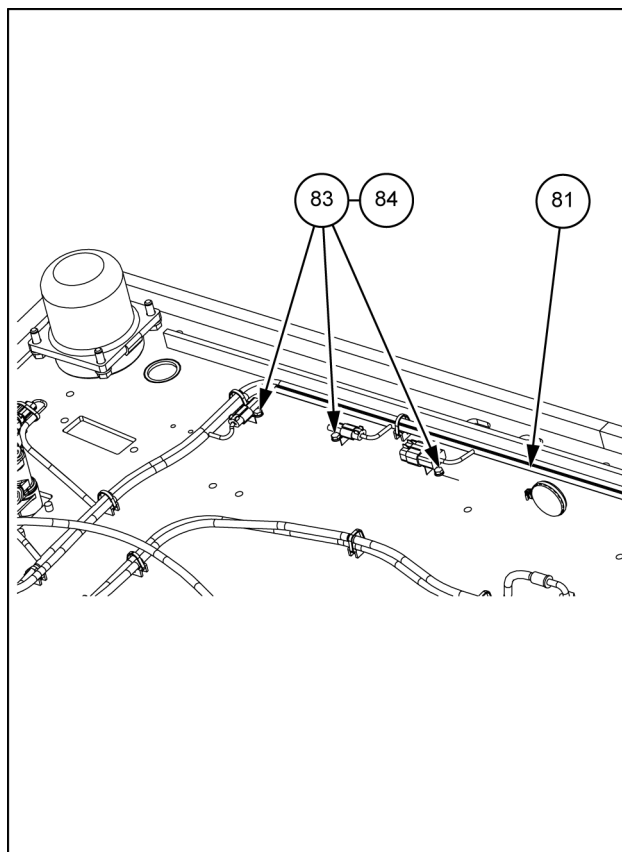

SMIL14II01078BB 5

4. Collegare il connettore del cablaggio (81) (8 pin) al cablaggio principale del telaio (*3) e fissare con la fascetta serrafili (82)

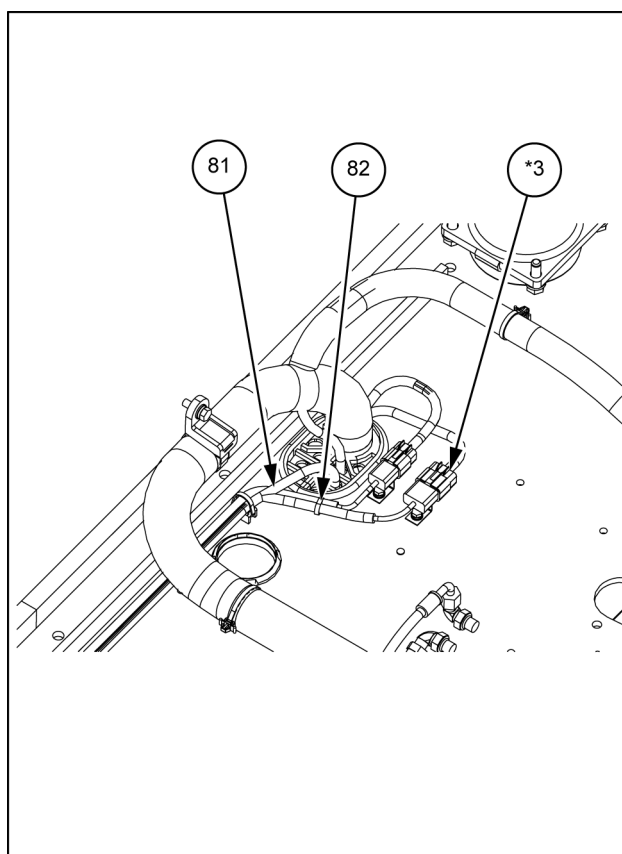

SMIL14II01079BB 6

Indice

C	
Contenuto del kit	1-1
M	
Montaggio cablaggio - Comando proporzionale	3-17
Montaggio della leva di comando	3-21
Montaggio della targhetta all'interno della cabina	3-27
Montaggio della tubazione del braccio	3-1
Montaggio della tubazione principale superiore	3-5
Montaggio sensore indicatore serbatoio (avvertenza ostruzione filtro)	3-25
Montaggio tubazione pressione pilota - Comando proporzionale	3-12
P	
Preparazione.	2-1

3 - MONTAJE

KIT DE CONTROL PROPORCIONAL DEL CIRCUITO DEL MARTILLO

Instalación del conducto del brazo

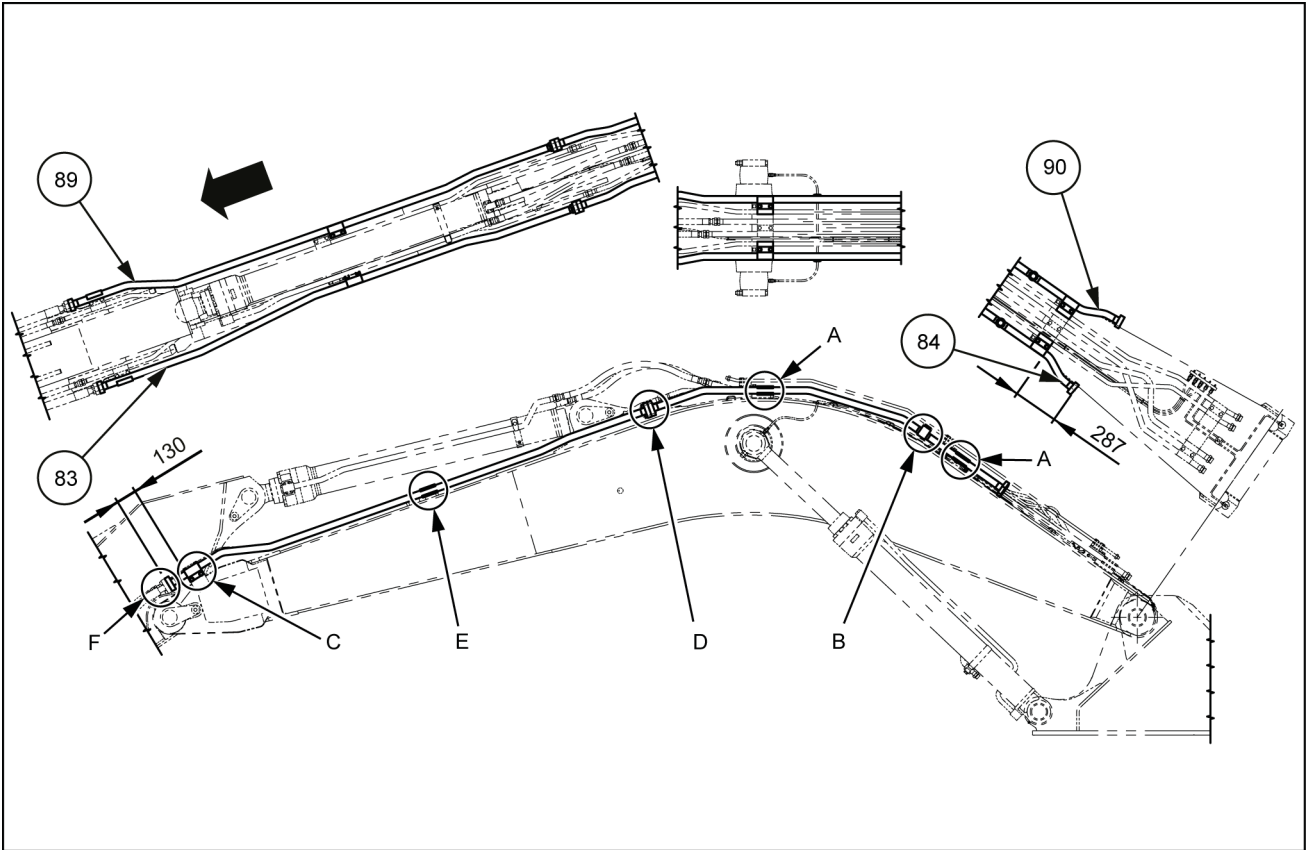

SMIL14CEX5781FB 1

6. Instale el casquillo (21) en el lado del conjunto de tubo (derecho) (*4) del colector (22) para conectar el adaptador de manguera (13). Instale la junta tórica (8) en el adaptador (13) y, a continuación, conecte la manguera hidráulica (15).

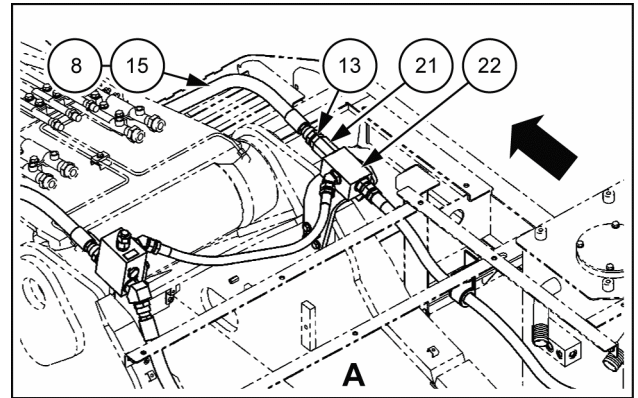

SMIL14CEX5801AB 12

7. Coloque la junta tórica (16) en la manguera hidráulica (15) y, a continuación, conéctela al conjunto de tubo (*4) con 2 bridas partidas (17) y 4 pernos de cabeza hueca hexagonal (18).

Instale el adaptador de manguera (29) en el lado de la válvula de sobrepresión (11) del colector (25). Conecte el puerto T de la válvula de descarga (11) y el lado de la válvula de descarga (11) del colector (25) con la manguera hidráulica (30).

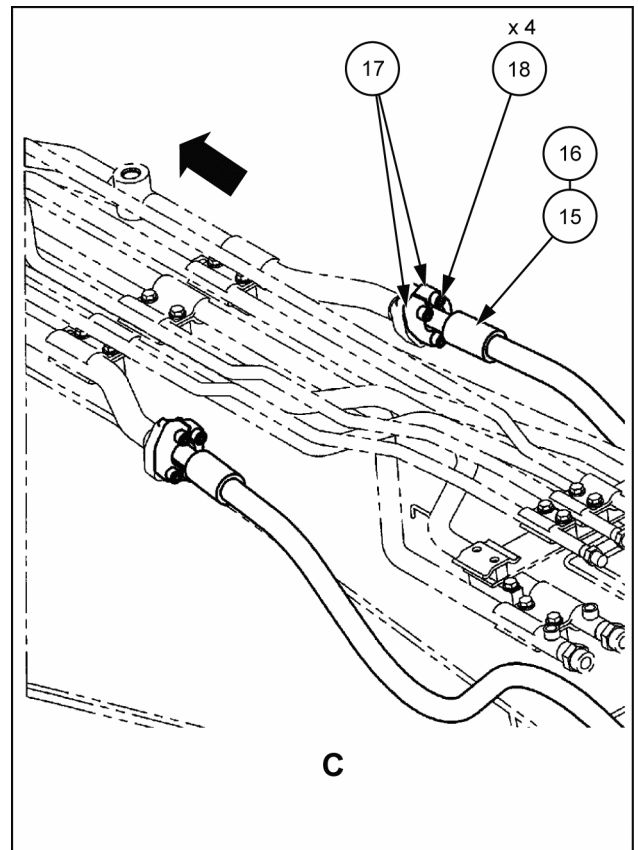

SMIL14CEX5802BB 13

Instalación de la palanca de control

Extracción de la palanca de control (derecha)

1. Enrolle la funda (*1) de la palanca de control y utilice el destornillador Phillips o la llave de boca 10 mm para quitar los 2 pernos (*2) de la tapa superior de la consola.

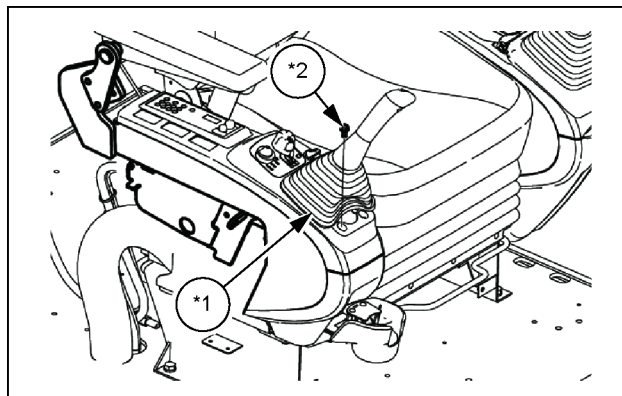

SMIL14II00167AB 1

2. Utilice el destornillador Phillips para retirar los 2 tornillos (*3) y retire luego el tirador de la palanca de inclinación (*4).

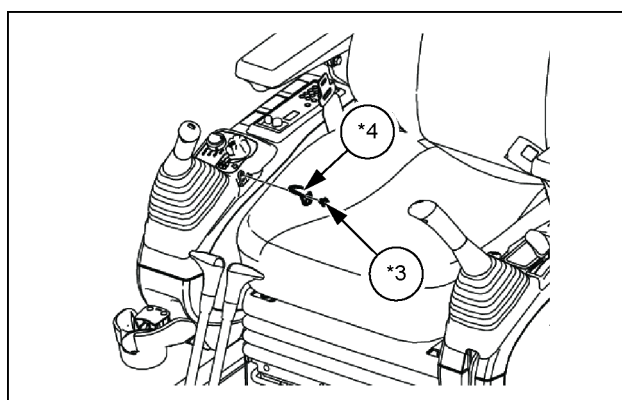

SMIL14II00168AB 2

3. Use un destornillador Phillips para desinstalar los 2 tornillos (*5), de la tapa superior de la consola.

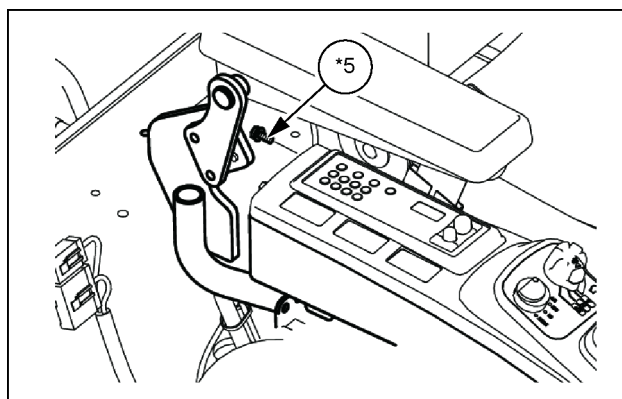

SMIL14II00169AB 3

4. Retire los conectores (*6) y quite la cubierta superior de la consola (*7).

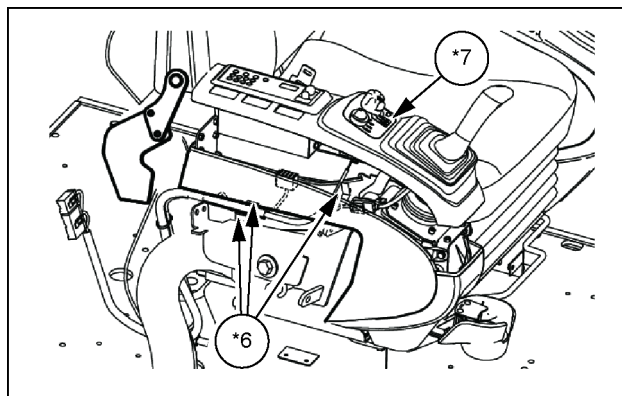

SMIL14II00170AB 4

CLICK HERE TO **DOWNLOAD** THE COMPLETE MANUAL

- Thank you very much for reading the preview of the manual.
- You can download the complete manual from: www.heydownloads.com by clicking the link below



- Please note: If there is no response to CLICKING the link, please download this PDF first and then click on it.

CLICK HERE TO **DOWNLOAD** THE COMPLETE MANUAL