

VOITH TURBO

Installation and Operating Manual

Turbo Couplings with Constant Fill

3626-011000 en

ATTENTION!

Please be sure to read this manual prior to installation and commissioning and keep it for further use!

Serial No. ¹⁾		
Coupling type		
Year of manufacture		
Mass (weight)		kg
Power transmission		kW
Input speed		rpm
Filling (mineral oil)		dm ³ (litre)
Response temperature of fusible plugs		°C
Type of connecting coupling		
Sound pressure level		dB(A)
Position	<input type="checkbox"/> horizontal <input type="checkbox"/> vertical	
Drive via	<input type="checkbox"/> outer wheel <input type="checkbox"/> inner wheel	

¹⁾ Please quote the serial number in all correspondence (→ section 15).

CLICK HERE TO **DOWNLOAD** THE COMPLETE MANUAL

- Thank you very much for reading the preview of the manual.
- You can download the complete manual from: www.heydownloads.com by clicking the link below



- Please note: If there is no response to CLICKING the link, please download this PDF first and then click on it.

CLICK HERE TO **DOWNLOAD** THE COMPLETE MANUAL

4 Function, Types

4.1 Function

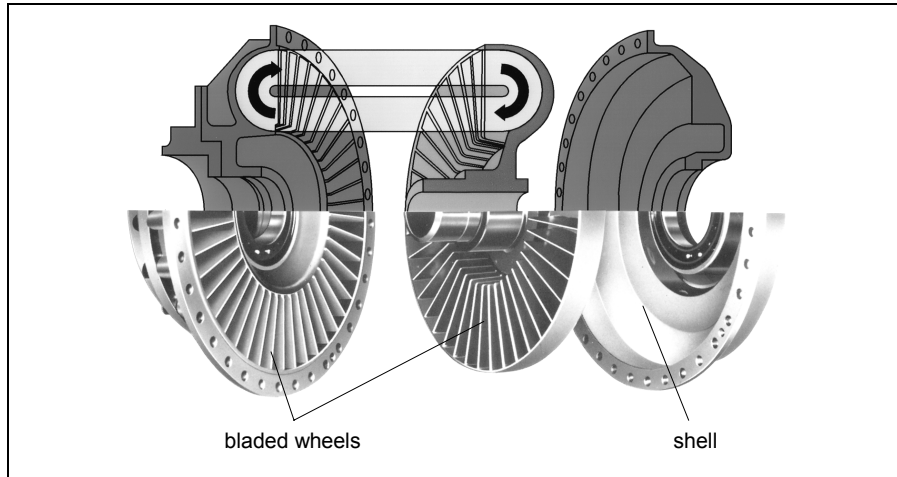

Fig. 1

The Voith turbo coupling is a hydrodynamic coupling working to the Föttinger principle. Its main components consist of two bladed wheels – the pump impeller and turbine wheel – enclosed by a shell. Both wheels are provided with bearings relative to each other. The power is transmitted virtually without wear, there is no mechanical contact between the power-transmitting parts. A constant amount of operating fluid is in the coupling.

The mechanical energy provided by the drive motor is converted to kinetic energy of the operating fluid in the connected pump impeller. In the turbine wheel this kinetic energy is converted back to mechanical energy.

Three conditions are to be considered with regard to the coupling function:

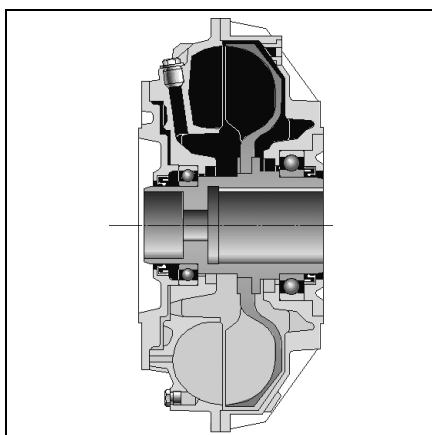

Fig. 2

– **Standstill:**

The total operating fluid is resting statically in the coupling.



ATTENTION!

Depending on the design of shaft, the coupling hub must be in contact with the shaft collar or the end face of shaft journal.

Couplings size 154 and 206:

- Insert a suitable and slightly oiled threaded rod in the shaft of the relevant machine.
- Mount the coupling on the shaft journal using a nut and a spacer tube.

Couplings size 274 to 1150:

- Oil the mounting spindle slightly.
- Mount the coupling on the shaft journal using the mounting spindle, the spacer tube and the holding disk.

→ **Mounting devices:**
section 6.4, page 22

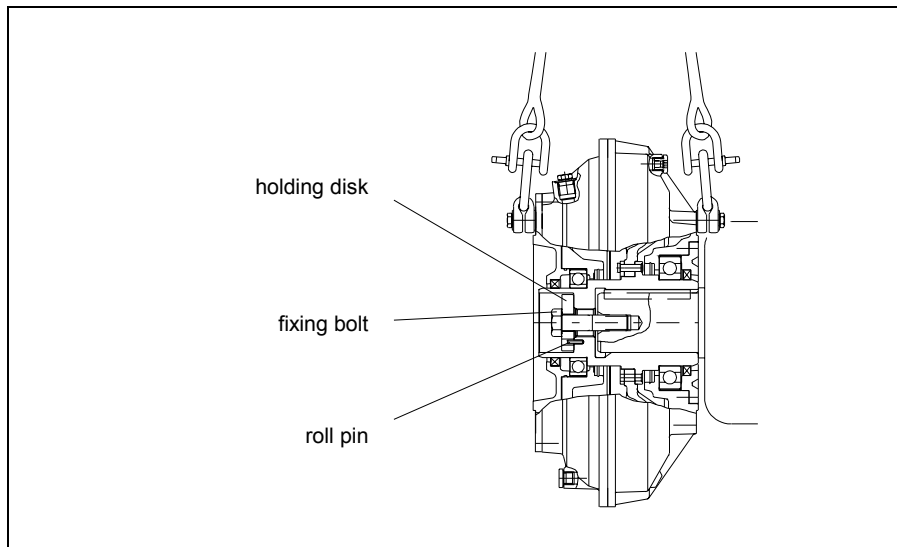

Fig. 18

- Check the proper seat of holding disk. Tighten the fixing bolt using the specified tightening torque.

→ **Tightening torque:**
section 5.1, page 16

ATTENTION!

The connecting coupling hub must either be in contact with the relevant shaft collar or secured in axial direction using a set screw. It is perhaps necessary to provide a spacer ring between hub and shaft collar.



- Mount the flexible connecting coupling hub on the relevant shaft journal. Careful warming up of the connecting coupling hub (to approx. 80°C) facilitates mounting.
- Tighten the set screw in the connecting coupling hub, if necessary.
- Move the connecting coupling hub with the relevant machine next to the turbo coupling. Observe proper seat of flexible elements in the connecting coupling!
- Fix the machine slightly.
- Align the drive.

→ **Section 8, page 25**

9.2 Proposed operating fluids

Supplier	Description	Pourpoint in °C	Flash point in °C	Class
Addinol	Hydr. Oil HLP 32	-30	220	HLP
Agip	Oso 32	-30	205	HLP
	Blasia 32	-29	215	CLP
Aral	Aral BG 32	-27	200	HLP
	Degol BG 32	-27	200	CLP
Aseol	Plus 16-110	-33	200	HLP
Autol	Hydr. Oil HY-S 32 ISO	-32	208	HLP
Avia	Avia Fluid RSL 32	-27	214	HLP
	Gear RSX 32 S	-33	207	CLP
BP	Energol HLP 32	-30	216	HLP
	Energol HLP-HM 32	-30	216	HLP
Castrol	Hyspin AWH-M 32	-42	214	HLP
	Hyspin SP 32	-28	220	HLP
CEPSA	CEPSA HIDROSIC HLP 32	-24	204	HLP
	EP 125	-30	206	HLP
DEA	Pentran 32	-30	210	HLP
Elf	Elfolna 32	-27	210	HLP
	Elfolna DS 32	-32	225	HLP
Esso	Nuto H 32	-33	210	HLP
Fina	Hydran VT 32	-30	214	HLP
Fuchs	Renolin B 10	-27	190	HLP
	Renolin MR 10	-27	200	HLP
Klüber	Lamora HLP 32	-30	200	HLP
Kuwait Petroleum	Q8 Holst 32	-30	208	HLP
	Q8 Haydn 32	-30	208	HLP
Mobil	Mobil SHC 524	<-63	234	HLP
	DTE 24	-30	218	HLP
Optimol	Hydo MV 32	-38	209	HLP
Shell	Tegula Oil 32	-33	210	HLP
SRS Salzbergen	Wiolan HS 32	-24	220	HLP
	Wiolan HF 32 Turbofluid	-27	200	HLP
Texaco	Randol HD 32	-30	196	HLP
Total	Azolla ZS 32	-21	220	HLP
Valvoline	M5-C600 B	-36	220	HLP

The above oil list is a recommendation and does not claim to be complete.

ATTENTION!

- The values mentioned for the pourpoint and flash point are approximate values and data originating from the oil suppliers. These may vary and Voith Turbo will not accept any warranty claims! Country-specific production of basic oils may result in different pourpoint, fire point and flash point values.
- In the event of critical applications, we suggest to consult the respective oil supplier!



12.5 Bearing lubrication

The operating fluid is used for lubrication of turbo coupling bearings.

ATTENTION!

- On account of the type of bearing used for standard turbo couplings size 366, 422, 487, 562, 650, 750, 866 and 1150, at least one standstill is required within a period of 3 months.
- On account of the type of bearings used for standard turbo couplings size 154, 206, 274 and 1000, at least one standstill is required once a week.



Note!

- Couplings **size 154, 206, 274, 366, 422, 487, 562, 650, 750 and 866** can be provided with special bearings allowing continuous operation and are filled with a lifetime grease.
- The Coupling **size 1000** can be provided with special bearings requiring only one standstill within a period of three months.



17.1 Spare parts for type 154 T

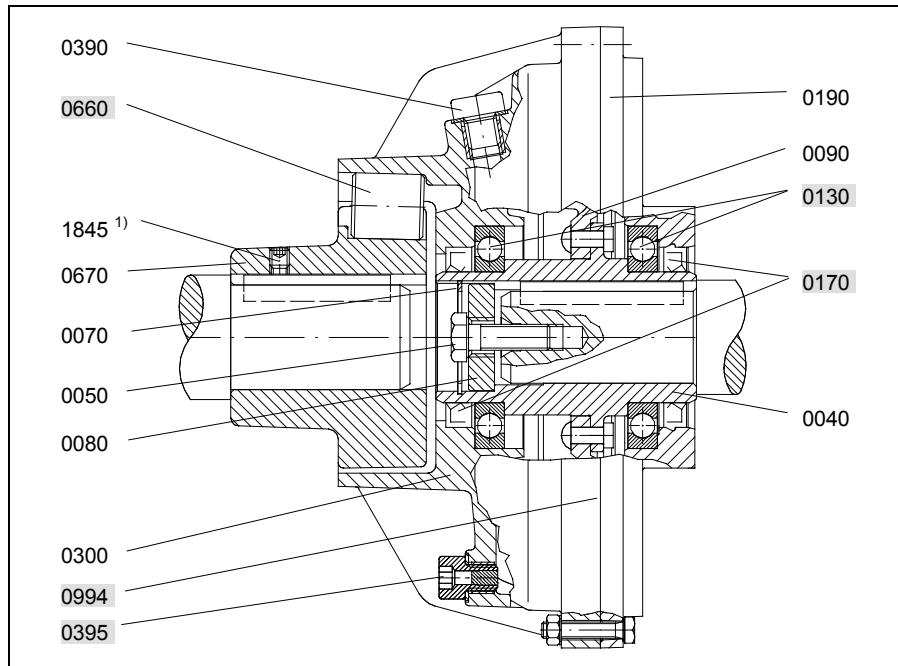

Fig. 40

17.2 Spare parts for type 206/274 T

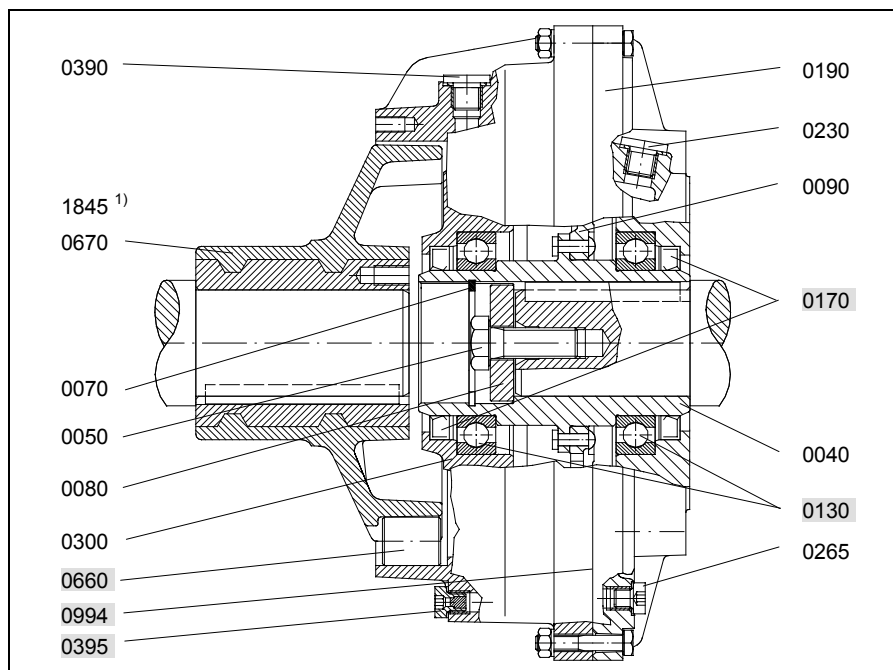

Fig. 41

Example of connecting
coupling type **ERK**.

→ Connecting couplings:
section 18, page 64

¹⁾ Optionally for connecting coupling type ERK, not shown as illustration!

		Screws and Standard parts		Wearing parts		Coupling main parts	
		206		206		206	
Item No.	Description	154	274	Item No.	Description	154	274
		T	T			T	T
0050	Fixing bolt	x	x	0130	Grooved ball bearing	x	x
0070	Circlip	x	x	0170	Radial shaft seal ring	x	x
0230	Filler plug		x	0395	Fusible plug	x	x
0265	Blind screw		x	0660	Flexible element	x	x
0390	Filler plug	x	x	0994	Seal	x	x
1845	Set screw		x	0670	Hub		x
							x
							x

17.8 Spare parts for types 206 DT and 274 DT/DTV

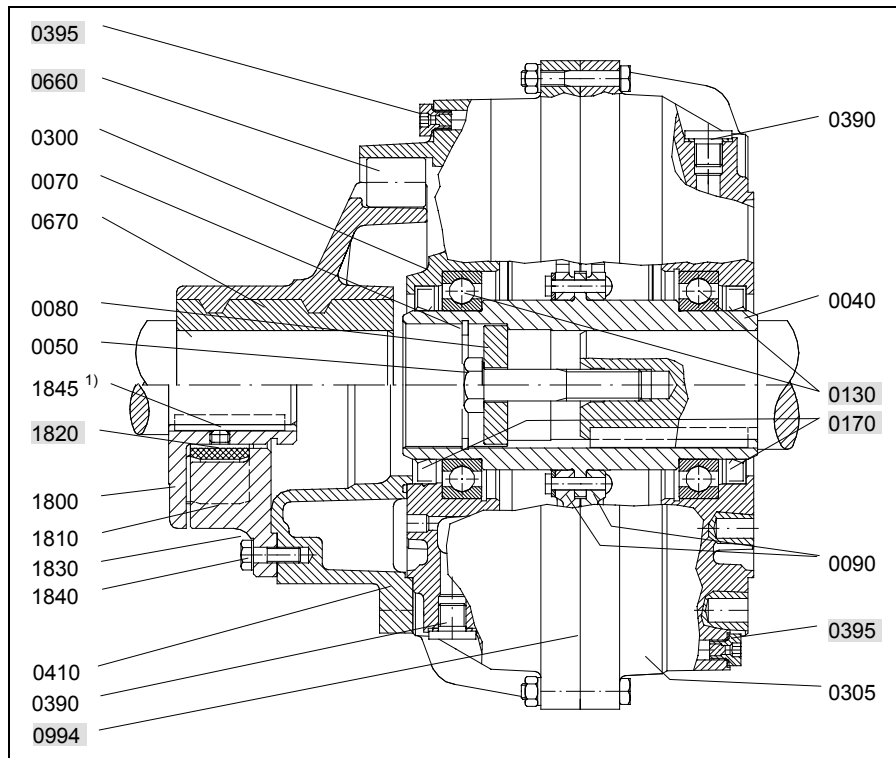

Upper Part:
Example of type **DT** with
connecting coupling
type **ERK**.

Lower Part:
Example of type **DTV** with
connecting coupling
type **ENK-SV**.

Fig. 53

¹⁾ Optional for connecting coupling type ENK-SV!

→ Connecting couplings:
section 18, page 64

Screws and Standard parts			Wearing parts			Coupling main parts			
Item No.	Benennung	DT/DTV	Item No.	Benennung	DT/DTV	Item No.	Benennung	DT	DTV
0050	Fixing bolt	x	0130	Grooved ball bearing	x	0040	Coupling hub	x	x
0070	Circlip	x	0170	Radial shaft seal ring	x	0080	Holding disk	x	x
0390	Filler plug	x	0395	Fusible plug	x	0090	Inner wheel	x	x
1830	Hex. Screw	x	0660	Flexible element	x	0300	Outer wheel	x	x
1840	Spring washer	x	0994	Seal	x	0305	Outer wheel	x	x
1845	Set screw	x	1820	Flexible element	x	0410	Delay chamber		x
						0670	Hub	x	x
						1800	Hub	x	x
						1810	Ring / Flange	x	x

CLICK HERE TO **DOWNLOAD** THE COMPLETE MANUAL

- Thank you very much for reading the preview of the manual.
- You can download the complete manual from: www.heydownloads.com by clicking the link below



- Please note: If there is no response to CLICKING the link, please download this PDF first and then click on it.

CLICK HERE TO **DOWNLOAD** THE COMPLETE MANUAL