

# CLAAS

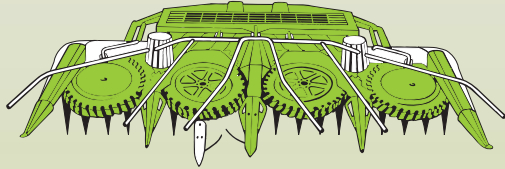

RU 600 Contour  
RU 600 Xtra  
RU 450 Xtra

**Anbauanleitung**

*Lagermaisspitzen*

**Fitting instructions**

*Down maize tips*

**Notice de montage**

*Pointes à maïs*

**Istruzioni di montaggio**

*Punte da mais allettato*

**Instrucciones de montaje**

*Puntas para maíz de ensilaje*

**SERVICE & PARTS**

CLICK HERE TO **DOWNLOAD** THE COMPLETE MANUAL

- Thank you very much for reading the preview of the manual.
- You can download the complete manual from: [www.heydownloads.com](http://www.heydownloads.com) by clicking the link below



- Please note: If there is no response to CLICKING the link, please download this PDF first and then click on it.

CLICK HERE TO **DOWNLOAD** THE COMPLETE MANUAL

# 5 Montage Lagermaisspitzen



**Beachten!**

Nachfolgende Arbeiten werden bei angebautem und ausgeklappten Maigebiss durchgeführt.



**Gefahr!**

Arbeiten am Maisgebiss grundsätzlich nur bei stillstehendem Motor vornehmen.

- Zündschlüssel abziehen!



**Gefahr!**

Bei Arbeiten unter angehobener Maschine/ Vorsatzgerät besteht Unfallgefahr

- Arbeiten unter angehobener Maschine/ Vorsatzgerät nur bei sicherer Abstützung durchführen.

RU 600 Contour / Xtra

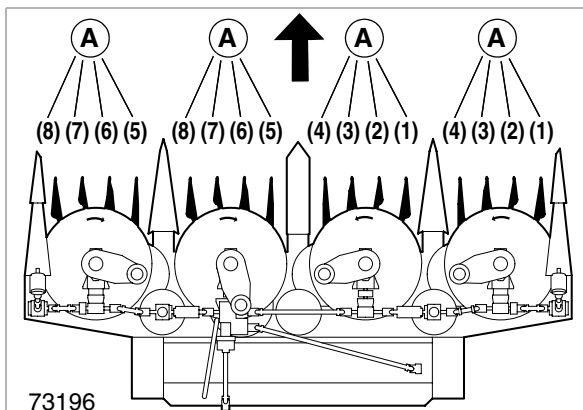

1

RU 450 Xtra

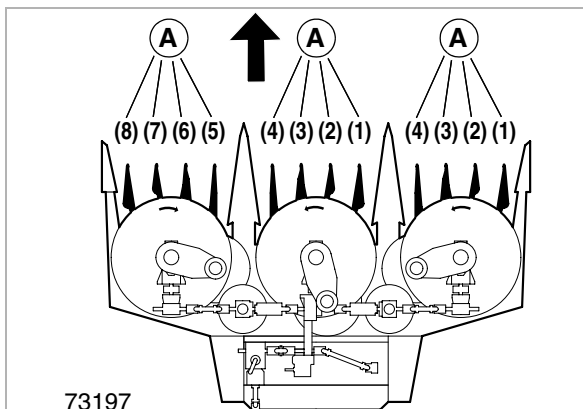

2

## EINWEIßFINGER DEMONTIEREN



**Beachten!**

Die Einweißfinger (A) sind im Originalzustand durchnummeriert.

- Bei unleserlicher Nummerierung mit wasserfestem Farbstift Einweißfinger (A) neu nummerieren.

(Abb. 1-2)

## 3 General instructions

### OF SPECIAL IMPORTANCE

The instructions set forth in this manual must be read carefully and followed by all persons concerned with the operation, maintenance, repair or inspection of this machine/front attachment in order to prevent accidents. Read and understand especially the »General instructions« section and the chapter on »Safety« in your operator's manual. Observe the pertinent accident prevention regulations of your country.

Clean the machine before starting work. Welding and grinding work on the machine may cause fire if accumulated vegetation, grease and dirt is not removed.

Before starting work make sure that all necessary tools and devices are at hand. Make a comparison between the present type of machine/ implement, the list in section "Shipping package" and the delivered kit.

For the specification of parts, e.g. screws, see the "Shipping package". In this list every mounting part has an item number. Further details regarding these parts are the part no., the quantity, the dimensions, the ISO/DIN and the use.

As a guideline, the existent parts in the installation instructions are marked with letters, while new parts are marked with numbers (item numbers).

Texts and figures are formulated neutrally, as far as possible. The differences between the models are pointed out by notes in the text.

Technical specifications, dimensions and weights are understood with the usual tolerances.

**IMPORTANT:** Front, rear, right and left refer to the direction of forward travel.

### IDENTIFICATION OF WARNINGS AND DANGERS

In this manual all text passages or graphics concerning your safety and the safety of the machine/ front attachment have been marked with the following symbols. Please supply all safety instructions to any other user.



#### Danger!

Failure to observe the instructions identified by this symbol results in danger for life and limb of the user or other persons.

- Measures for avoiding danger.



#### Caution!

Failure to observe the instructions identified by this symbol may result in damage to the machine/front attachment.

- Measures for avoiding danger to the machine/front attachment.



#### Note!

This symbol identifies instructions for more efficient and economical use of the machine/ front attachment.



#### Important!

This symbol identifies instructions for dismantling/assembly.



#### Environment!

Failure to observe the instructions identified by this symbol results in damage to the environment.

The environment is in danger if environmentally hazardous material (e.g. waste oil) is not subject to correct use and/or disposal.

**FR**

***Notice de montage***

***Pointes à maïs***

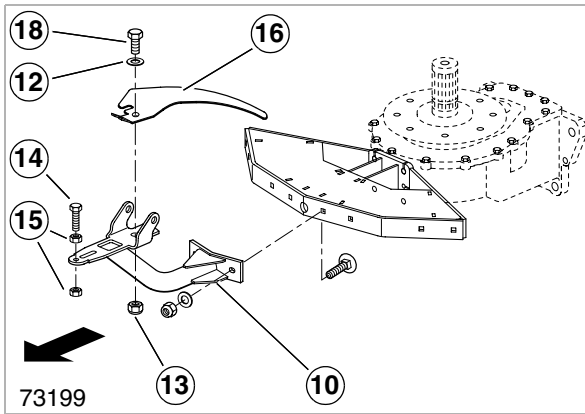

7

Monter les capteurs de position (16, 17) sur les supports (10) de la manière suivante.

- Accrocher le capteur de position droit (16) sur les 1er et 2es supports (10) à partir de la droite et le monter avec les vis à tête hexagonale (18) (M10x20), les rondelles contact (12) et les écrous freins (13).
- Pré-monter les vis à tête hexagonale (14) (M12x50) avec les écrous hexagonaux (15) pour le réglage en hauteur de la pointe intermédiaire.

(fig. 7)

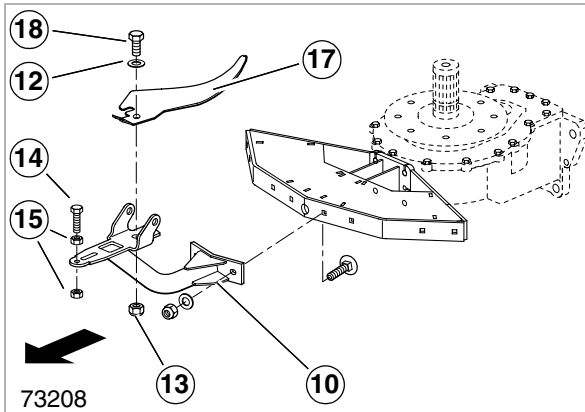

8

- Accrocher le capteur de position gauche (17) sur le 3e support (10) et, sur le RU 600, en plus sur le 4e support (10) à partir de la droite et le monter avec les vis à tête hexagonale (18) (M10x20), les rondelles contact (12) et les écrous freins (13).
- Pré-monter les vis à tête hexagonale (14) (M12x50) avec les écrous hexagonaux (15) pour le réglage en hauteur de la pointe intermédiaire.

(fig. 8)

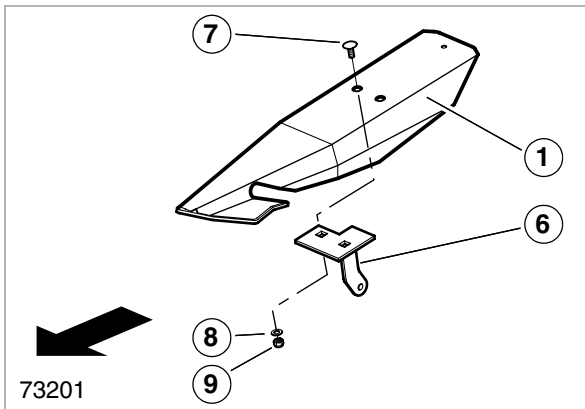

9

Pré-monter la pointe intermédiaire (1) de la manière suivante.

- Monter l'équerre de butée (6) avec les vis à tête bombée (7) (M8x20), les rondelles contact (8) et les écrous freins (9) sur la pointe intermédiaire (1).

(fig. 9)

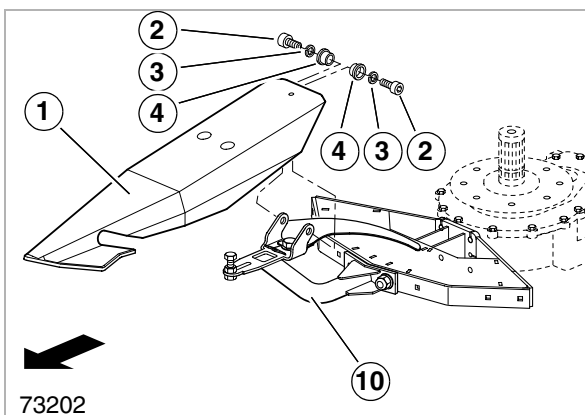

10

Monter la pointe intermédiaire pré-montée (1) de la manière suivante.

- Monter la pointe intermédiaire (1) avec les vis à tête cylindrique (2) (M12x30), les anneaux à bord d'arrêt (3) et les douilles (4) sur les supports (10).

(fig. 10)

## ***4 Complessivo di fornitura***

# 1 Introducción

## INTRODUCCIÓN

Estas instrucciones describen el procedimiento más rápido y seguro para el montaje adicional de los juegos de montaje n.º de pieza de repuesto 932 597.0 (puntas para maíz de ensilaje RU 600) y n.º de pieza de montaje 932 596.0 (puntas para maíz de ensilaje RU 450).

¡Lea detenidamente estas introducciones antes de iniciar cualquier trabajo! Preste especial atención a la sección »**Indicaciones generales**«.

Pueden modificarse las siguientes máquinas y los siguientes dispositivos:

Cabezal de maíz CLAAS:

RU 600 Contour

RU 600 Xtra

RU 450 Xtra

El conjunto de suministro se especifica en la página 4.2. Asegúrese de que el juego de montaje está completo antes de iniciar cualquier trabajo.

Observe la lista "Conjunto de suministro" como ampliación del catálogo de despiece.

Eliminar las piezas antiguas que no se utilicen en el conjunto de forma respetuosa con el medio ambiente.

Servicio post-venta CLAAS

CLICK HERE TO **DOWNLOAD** THE COMPLETE MANUAL

- Thank you very much for reading the preview of the manual.
- You can download the complete manual from: [www.heydownloads.com](http://www.heydownloads.com) by clicking the link below



- Please note: If there is no response to CLICKING the link, please download this PDF first and then click on it.

CLICK HERE TO **DOWNLOAD** THE COMPLETE MANUAL