

CLAAS

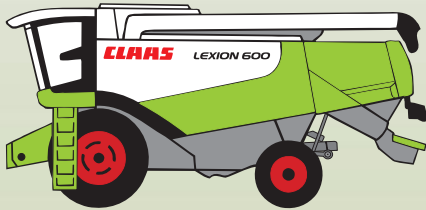

LEXION 600 - 510

Anbauanleitung
Strohverteiler

Fitting Instructions
Straw Spreader

Notice de montage
Éparpilleur de paille

SERVICE & PARTS

CLICK HERE TO **DOWNLOAD** THE COMPLETE MANUAL

- Thank you very much for reading the preview of the manual.
- You can download the complete manual from: www.heydownloads.com by clicking the link below



- Please note: If there is no response to CLICKING the link, please download this PDF first and then click on it.

CLICK HERE TO **DOWNLOAD** THE COMPLETE MANUAL

Nachrüstsatz Strohverteiler 000 782 302 0; 000 783 839 0; 000 783 869 0; 000 783 870 0				
Pos.-Nr.	Bezeichnung	Abmessungen	Norm ISO/DIN	Anzahl
	Haken *	A 50		4
10	Schlauchleitung	1SN 8 NN 5100		1
11	Winkelstutzen *	SWE-L10		1
12	Schlauchleitung	2SC 12 NN 2200		1
13	Winkelstutzen *	SWE-L15		2
14	Schlauchleitung	2SN12 NN 2850		1
15	Verbindungsstutzen *	S-L15		1
16	Gummilager *	22/22		5
	Befestigungsschelle *	2X24X25X3		5
	Sechskantschraube *	M 8X55		5
17	Rohrschelle *	D1-15X20		5
	Sechskantschraube *	M08X25		1
	Contact-Scheibe *	A 8		1
	Sechskantmutter *	M8		1
18	Kabelbinder *	MIN. 7,6X282		1
19	Kabelbinder *	MIN. 4,7X188		2
* Bauteil nicht abgebildet!				
** nicht bei LEXION Typ 589, 586, 585, 581				

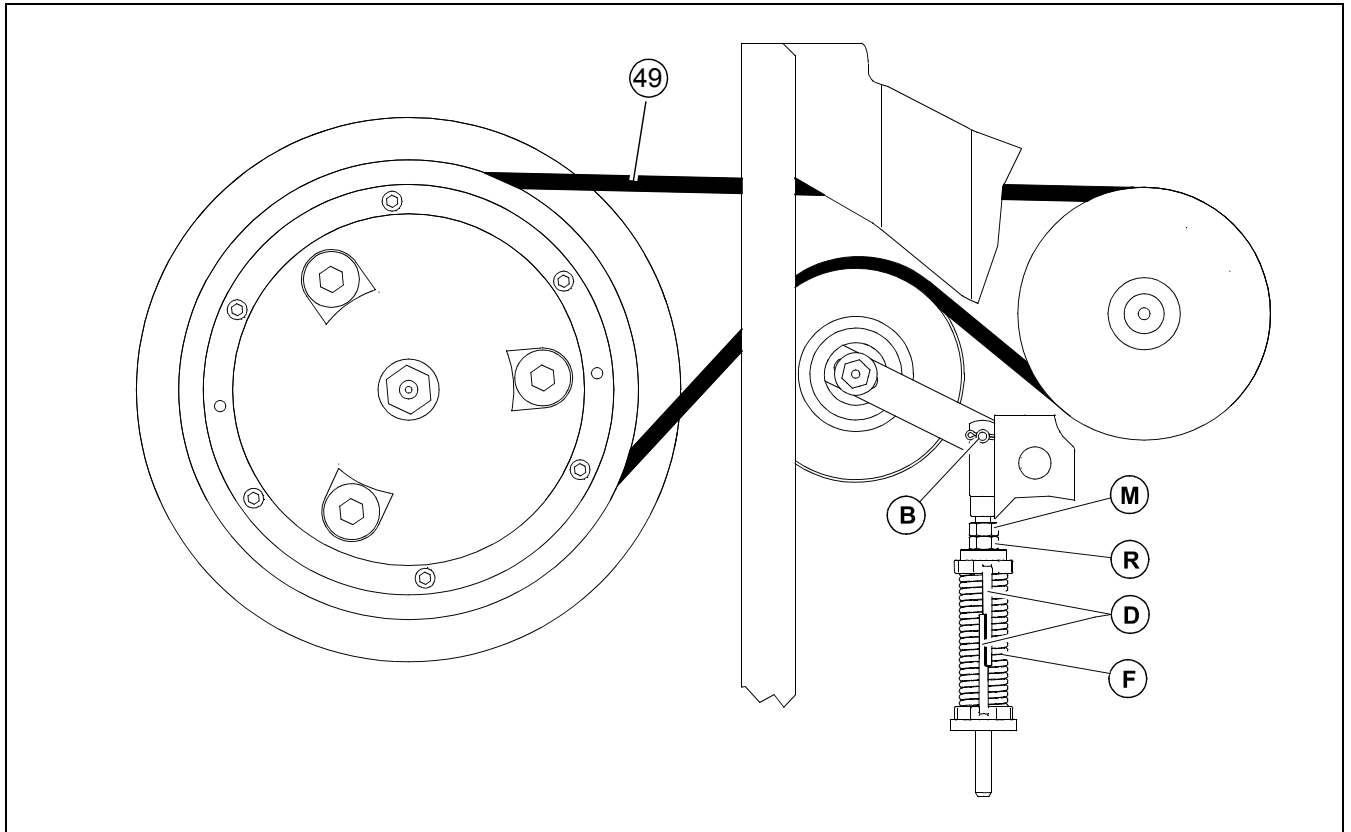

24109 **19**



Warnung!

Quetschgefahr bei Montagen.

Quetschungen von Gliedmaßen.

- Gliedmaße vom Gefahrenbereich fernhalten.
- Geeignetes Werkzeug verwenden.

- Riemen (49) auflegen.
- Bolzen (B) einsetzen und mit Splint sichern.
- Bundmutter (K) abschrauben.
- Riemen (49) einstellen.

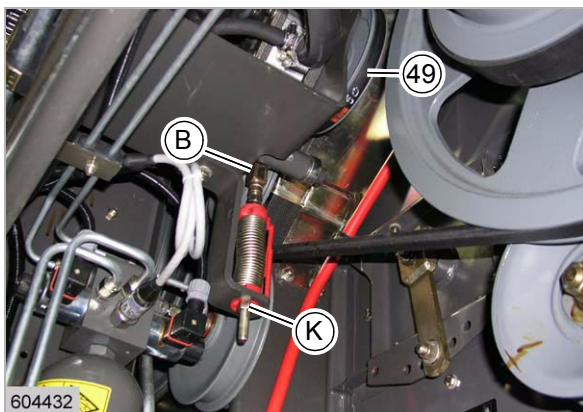

1446

20

Search and find

The wanted subject can easily be found with the recurring subassembly structure, using the table of contents or the header line of this manual.

In addition, the index of this manual is a useful tool for locating a specific subject. The index can be found on the last pages of this manual.

Directions

Text elements such as front, rear, right and left always apply to the direction of travel. In figures, the direction of travel may be indicated by a direction arrow.

Your CLAAS Service Department

1.1.2 Validity of instructions

These instructions apply to the following machine / front attachment:

Designation	TYPE	Machine serial number	
		from	to
LEXION 600	589	58900011	—
LEXION 580	586	58600011	—
LEXION 570	585	58500011	—
LEXION 560/550/540	584	58400011	—
LEXION 530/520/510	583	58300011	—
LEXION 530/520 Montana	582	58200011	—
LEXION 570 Montana	581	58100011	—
LEXION 560/550 Montana	580	58000011	—

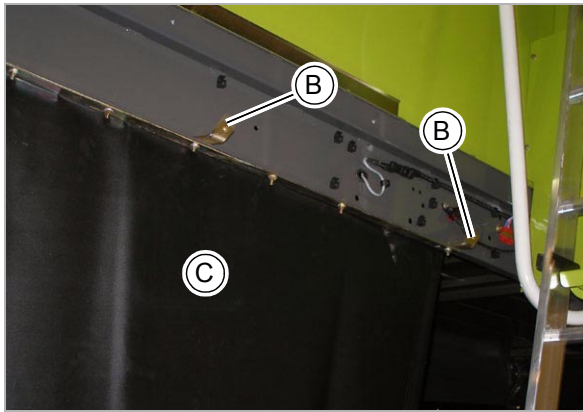

2

23995

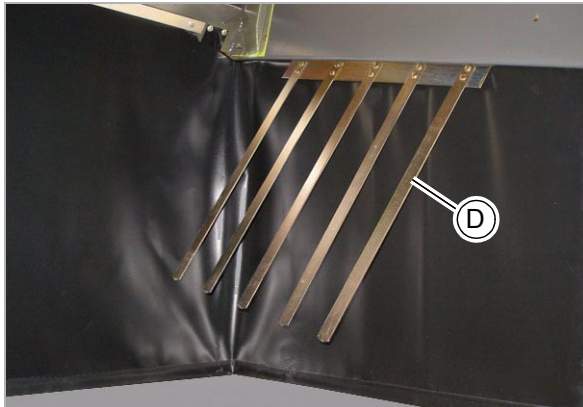

3

23999

- Mark position of brackets (B).
- Unscrew brackets (B).
- Repeat this process on the other side of the machine.
- Unscrew straw guide apron (C).
- Back up finger rakes (D) on the inside.

4.1.4 Removing the stage 1 front attachment drive belt

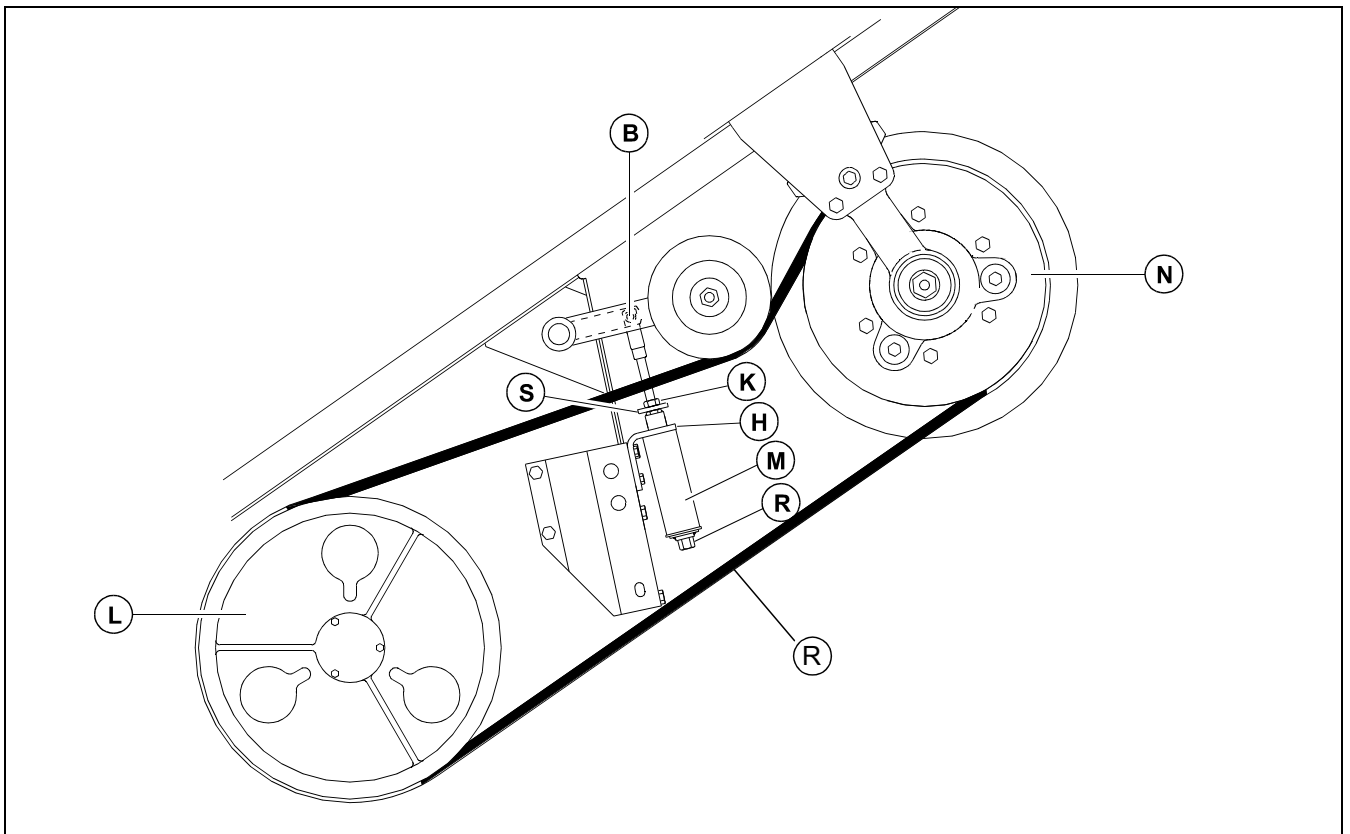

24118

4

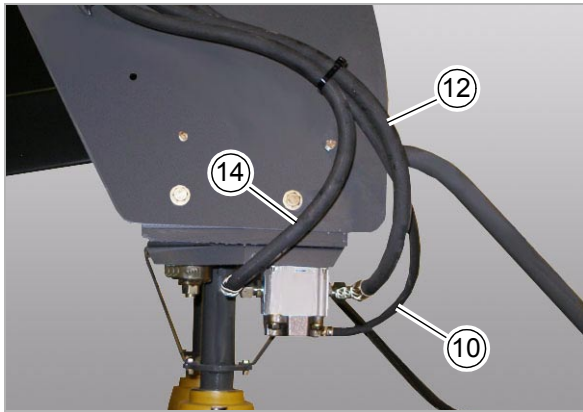

35

24060

for LEXION types 584, 583, 582, 580:

- Screw hoses (12) and (14) with connector (13) to the hydraulic motor.
- Screw hose (10) with connector (11) to the hydraulic motor.

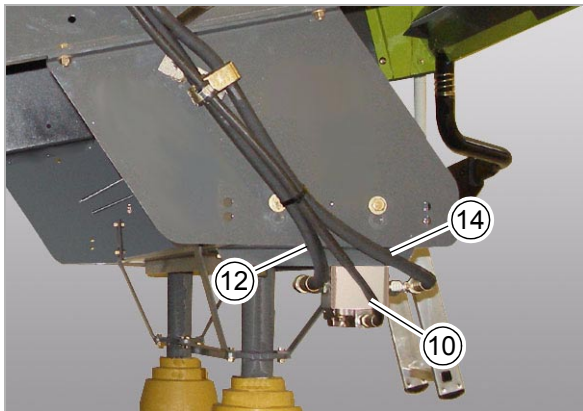

36

24122

for LEXION types 589, 586, 585, 581:

- Screw hoses (12) and (14) with connector (13) to the hydraulic motor.
- Screw hose (10) with connector (11) to the hydraulic motor.

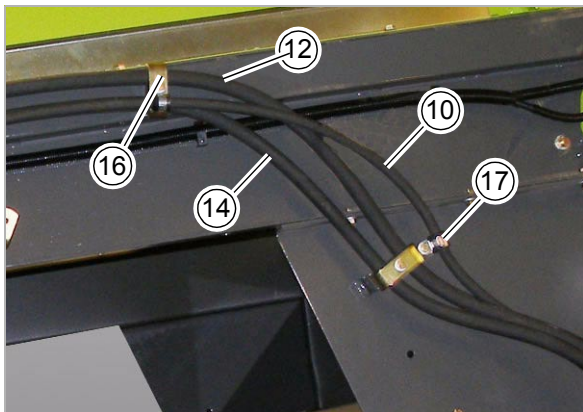

37

24057

- Screw hoses (12) and (14) with clamps (16).
- Screw hose (10) with clamp (17).

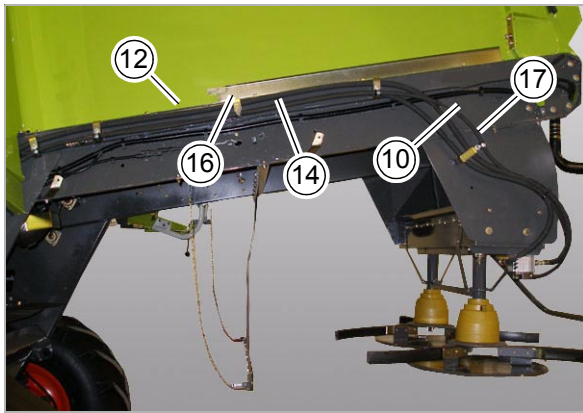

38

24049



23956

3

Kit d'équipement ultérieur éparpilleur de paille 000 782 302 0; 000 783 839 0; 000 783 869 0; 000 783 870 0

N° pos.	Désignation	Dimensions	Norme ISO/DIN	Quantité
20	Autocollant	168 X 88 - transversal		2
21	Autocollant	60 X 116 - Haut		1
22	Autocollant	60 X 116 - Haut		1
23	Autocollant	116 X 60 - transversal		2
24	Autocollant	116 X 60 - transversal		1

* composant non représenté !

** sauf sur LEXION types 589, 586, 585, 581

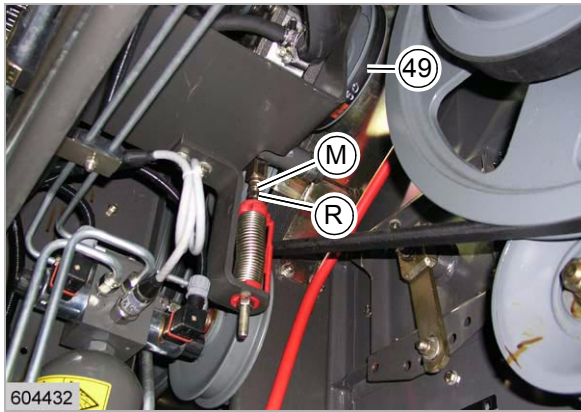

21

1446

- Desserrer les écrous (M) et (R).

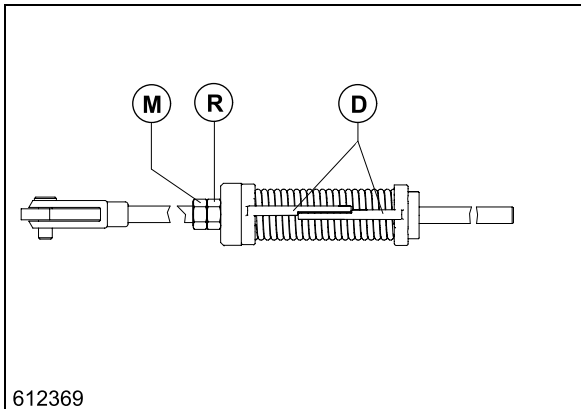

22

1447

- Régler le vérin à ressort (F) :
 - Régler les écrous (M) et (R) pour que les deux règles (D) soient l'une au dessus de l'autre sans jeu à l'extrémité des surfaces chanfreinées.
 - Longueur du ressort = 100 mm**
 - Bloquer les écrous (M) et (R).

4.1.6 Poser la courroie 1ère position d'entraînement de l'outil frontal

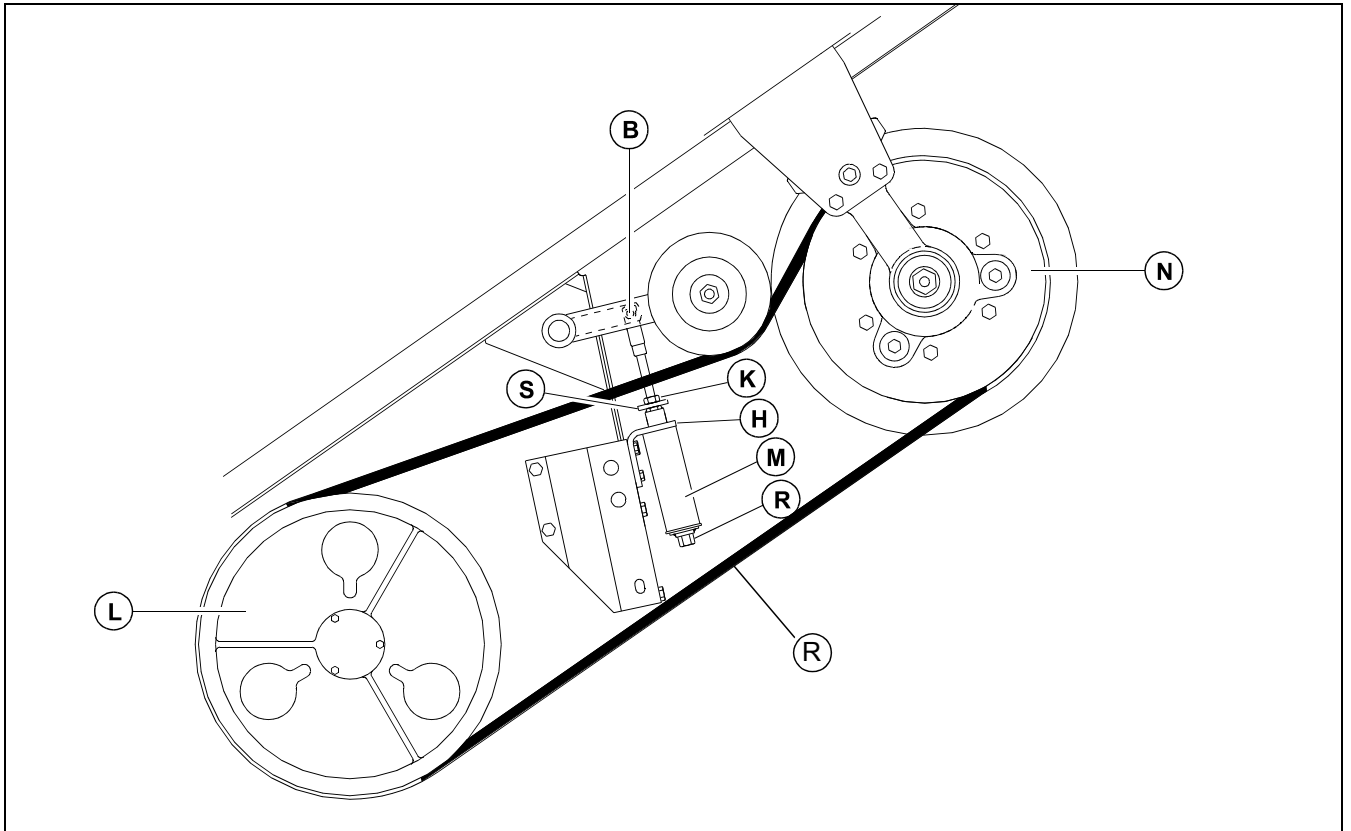

24118 23

CLICK HERE TO **DOWNLOAD** THE COMPLETE MANUAL

- Thank you very much for reading the preview of the manual.
- You can download the complete manual from: www.heydownloads.com by clicking the link below



- Please note: If there is no response to CLICKING the link, please download this PDF first and then click on it.

CLICK HERE TO **DOWNLOAD** THE COMPLETE MANUAL