

Field Assembly Instruction

ARTICULATED
DUMP TRUCK

HM300-5E0

SERIAL NUMBERS 20001 and up

KOMATSU

CLICK HERE TO **DOWNLOAD** THE COMPLETE MANUAL

- Thank you very much for reading the preview of the manual.
- You can download the complete manual from: www.heydownloads.com by clicking the link below



- Please note: If there is no response to CLICKING the link, please download this PDF first and then click on it.

CLICK HERE TO **DOWNLOAD** THE COMPLETE MANUAL

1 Installation of cab step and guard

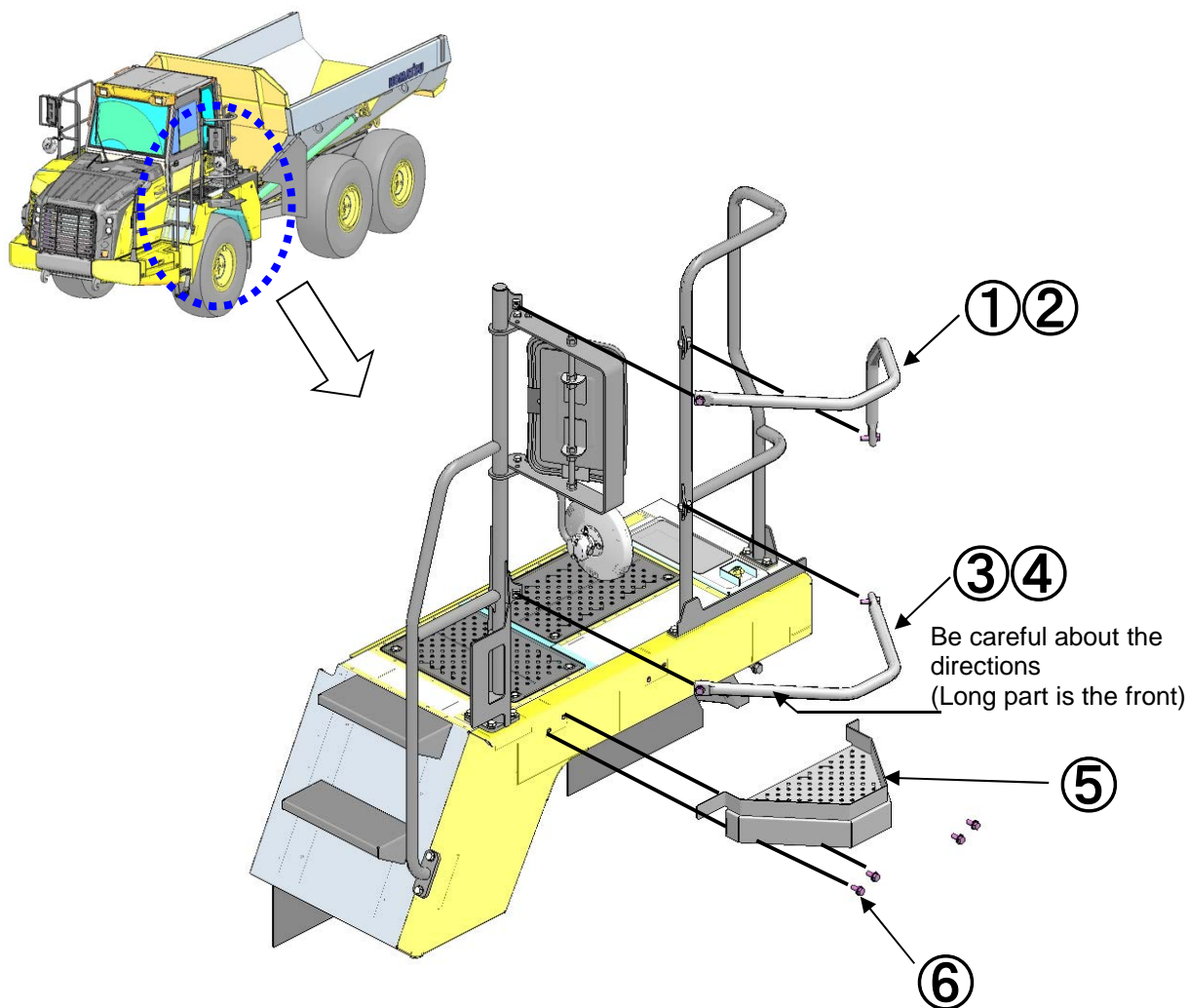

	Part No.	Part name	Q'ty	State of part (part list No.)
①	56D-54-37340	GUARD	1	Separate shipment (M35-03-020)
②	01024-81245	BOLT, SEMS	2	Install it to the machine loosely.
③	56D-54-37330	GUARD	1	Separate shipment (M35-03-020)
④	01024-81245	BOLT, SEMS	2	Install it to the machine loosely.
⑤	56D-54-37350	STEP	1	Separate shipment (M35-03-020)
⑥	01024-81245	BOLT, SEMS	4	Install it to the machine loosely.

1. Remove the bolts which have been tightened lightly to the guard and fender.

2. Install guard and step to the fender.

Precautions	Tools to be used		Facility to be used	
	Name	Q'ty	Name	Q'ty
	Ratchet handle	1	Stepladder (scaffold)	1
	Socket (19 mm)	1		
	Other remarks			

1 Perform the sub-assembly of the dump body

- 1) Install lock pins.
- 2) Install mudguard.

Work on right and left sides similarly

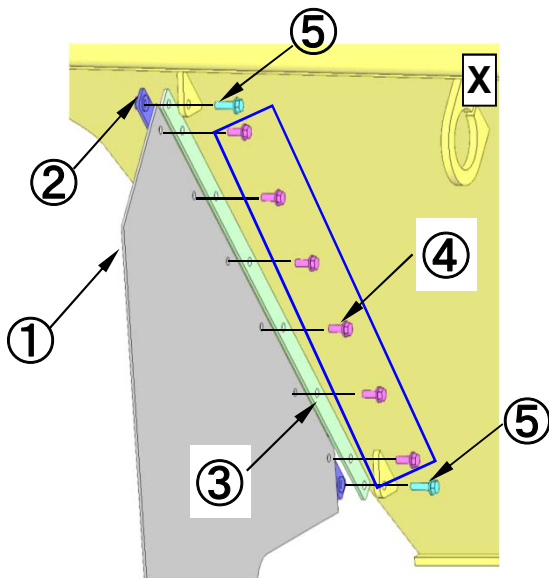
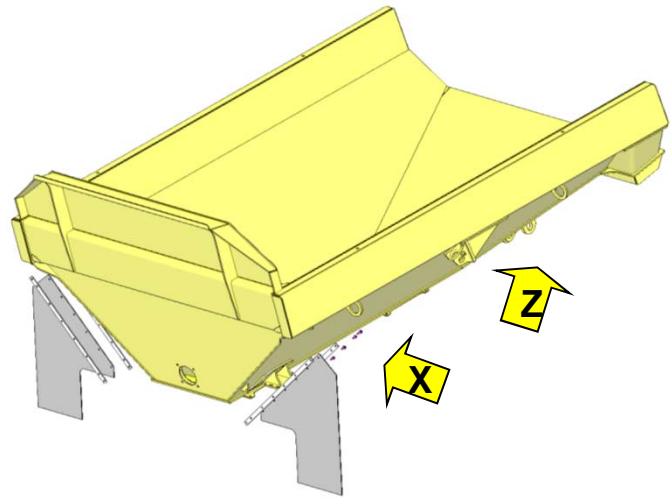

Pass through the seat attached to the body, and open tip of pins.

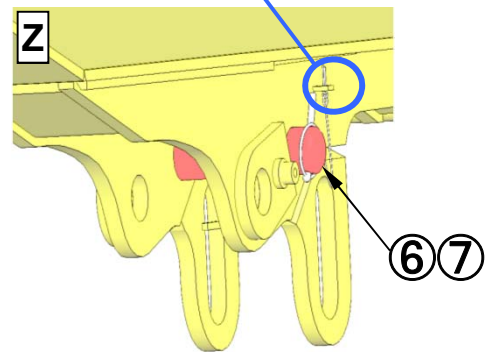

	Part No.	Part name	Q'ty	State of part (list No. of parts shipped with machine)
①	56D-74-51550	GUARD	2	Separately Packed(M35-04-110)
②	56B-74-11760	PLATE	2	Separately Packed(M35-04-110)
③	56B-74-11770	PLATE	2	Separately Packed(M35-04-110)
④	01024-81235	BOLT, SEMS	12	Separately Packed(M35-04-110)
⑤	01024-81245	BOLT, SEMS	4	Separately Packed(M35-04-110)
⑥	56E-74-27730	PIN (Q)	2	Separately Packed(M35-04-110)
⑦	569-74-61470	LINCH PIN	2	Separately Packed(M35-04-110)

Precautions

Tools to be used

Facility to be used

Name	Q'ty	Name	Q'ty
Impact wrench	1		
Socket (19 mm)	1		
Socket (24 mm)	1		

Other remarks

1 Install the dump body

- 1) Remove pin etc. which has been installed loosely.
- 2) Sling the dump body again.
- 3) Place the dump body to the mounting part of rear frame, and install the pin.
- 4) Tighten the pin fixing bolt with the torque described.

Work on right and left sides similarly

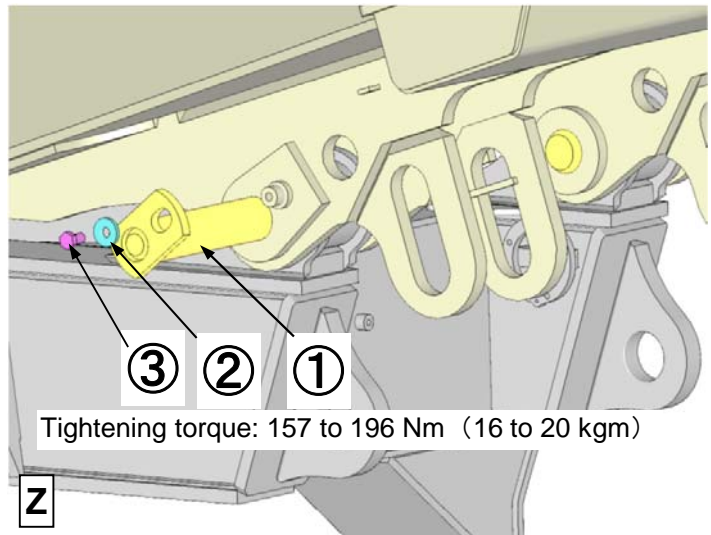
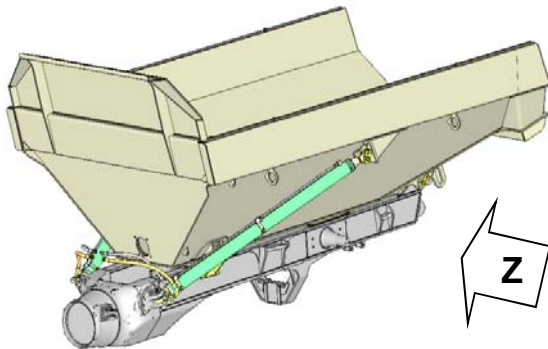

Check that the washer mounting seating face for pin fixing seat is free from the paint. If paint still remains, remove the paint surface completely by using paint thinner or etc.

Be sure to secure (3) clearance

DO NOT PAINT

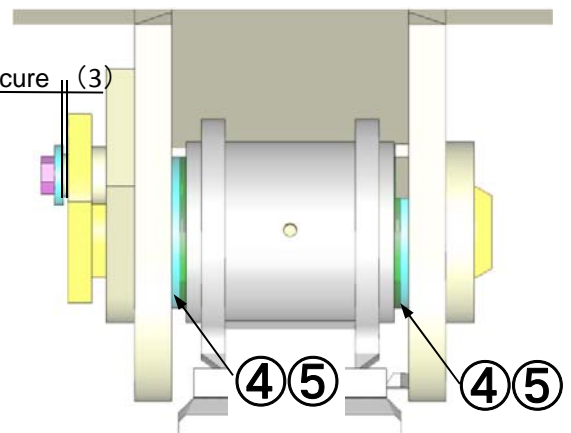
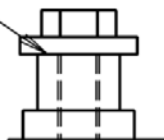

	Part No.	Part name	Q'ty	State of part (part list No.)
①	56B-74-11510	PIN	2	M35-04-150
②	569-40-61710	WASHER	2	M35-04-150
③	01010-81425	BOLT	2	M35-04-150
④	566-74-11270	SPACER (t = 6 mm)	4	M35-04-150
⑤	566-74-11280	SPACER (t = 1 mm)	16	M35-04-150

Precautions

Tools to be used

Facility to be used

Name	Q'ty	Name	Q'ty
Impact wrench	1		
Socket (22 mm)	1		
Torque wrench	1		
(RSP220N x 22 or equivalent)			

Other remarks

1 Stick decals to the dump body (right and left).

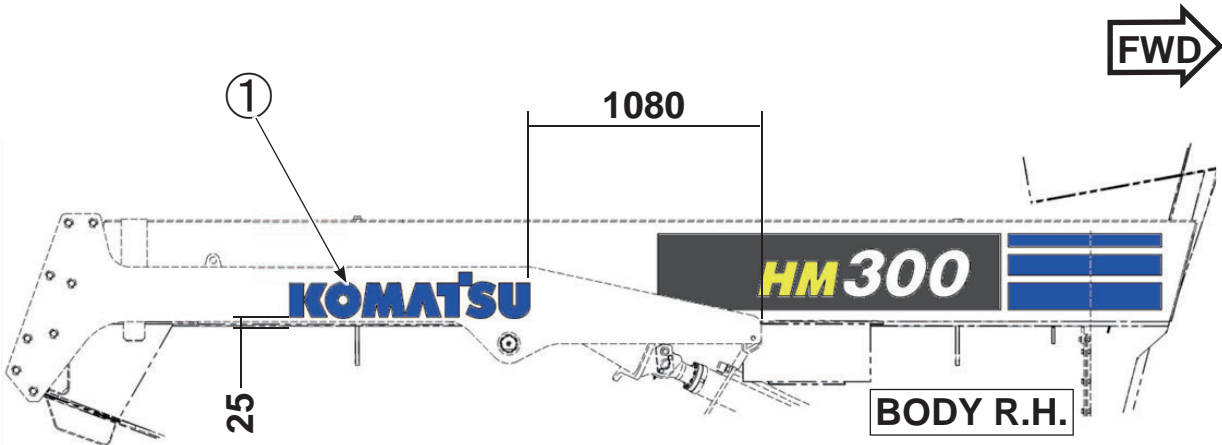
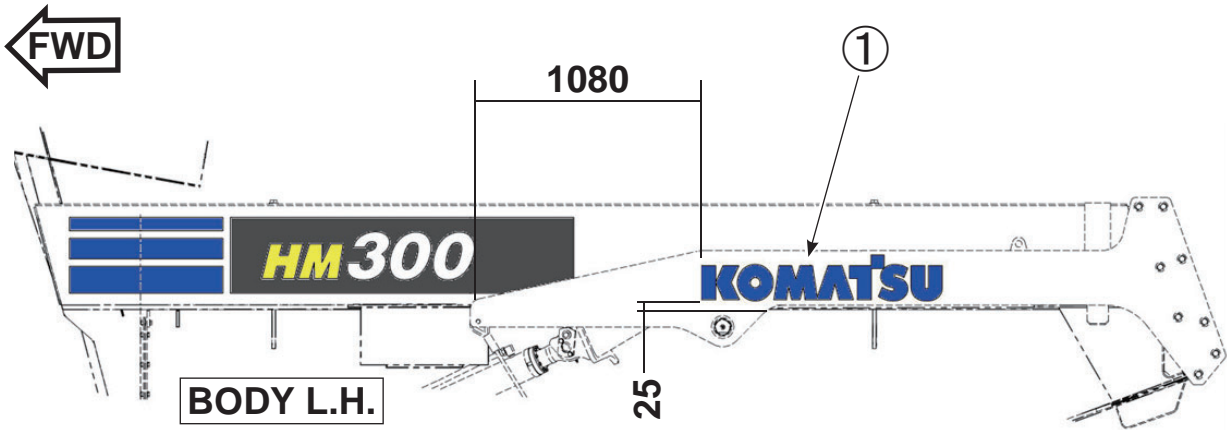

	Part No.	Part name	Q'ty	State of part (part list No.)
①	09690-A1120	MARK	2	M35-04-140

Precautions

Stick each decal perfectly with no bubbles under it.

Tools to be used

Facility to be used

Name	Q'ty	Name	Q'ty

Other remarks

Perform this work when installing only tailgate on site to machine with dump body.

1 Adjustment of mirror

Adjust according to the figure below.
 See each mirror from operator's seat.
 Adjust the mirror so that a part of the machine projected to the mirror becomes as described in the figure below.

ミラー番号 MIRROR NUMBER	視認範囲 RANGE OF VIEW
①	斜線部Aが見えること。 SEE THE CROSS HATCHED AREA A.
②	斜線部B、タイヤ接地点D、及び地面Fが見えること。 SEE THE CROSS HATCHED AREA B, THE GROUND CONTACT POINTS OF TIRE D, AND GROUND POINT F.
③	機体の左側方が見えること。 SEE THE BODY LEFT SIDE.
④	斜線部C、タイヤ接地点E、及び地面Gが見えること。 SEE THE CROSS HATCHED AREA C, THE GROUND CONTACT POINTS OF TIRE E, AND GROUND POINT G.
⑤	機体の右側方が見えること。 SEE THE BODY RIGHT SIDE.
リアモニタ REAR MONITOR	モニタ内の目安線の縦線がJと、横線がIと合っていること。 FIT LINE J TO THE VERTICAL GUIDELINE, AND FIT LINE I TO THE HORIZONTAL GUIDELINE, IN THE MONITOR.

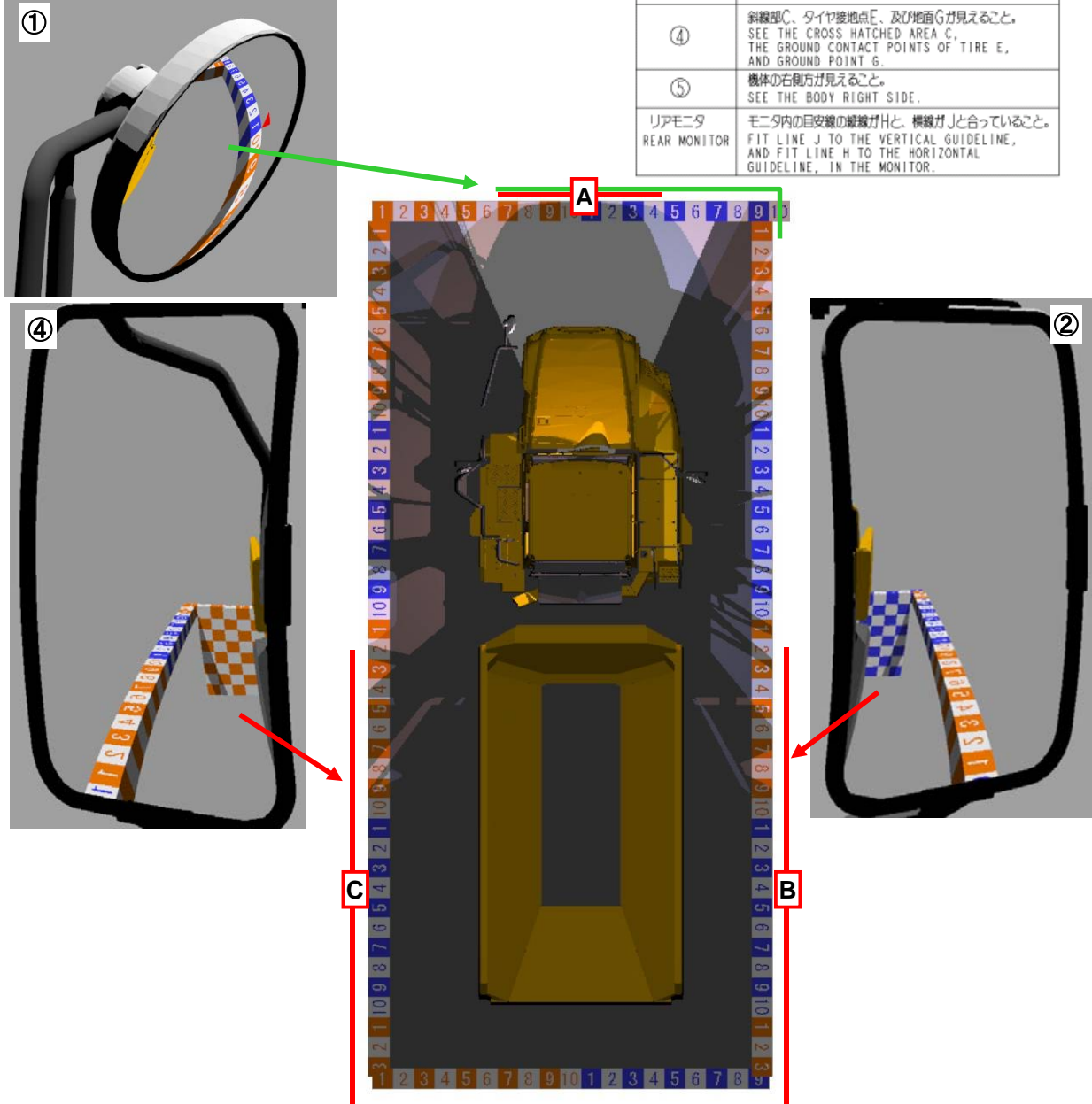

Precautions

Tools to be used

Facility to be used

Name

Q'ty

Name

Q'ty

Other remarks

CLICK HERE TO **DOWNLOAD** THE COMPLETE MANUAL

- Thank you very much for reading the preview of the manual.
- You can download the complete manual from: www.heydownloads.com by clicking the link below



- Please note: If there is no response to CLICKING the link, please download this PDF first and then click on it.

CLICK HERE TO **DOWNLOAD** THE COMPLETE MANUAL