

51. ENGINE

TABLE OF CONTENTS

This service manual explains the single engine. Note that this manual is edited without modification by based on the service manual of HINO MOTOR.

CLICK HERE TO **DOWNLOAD** THE COMPLETE MANUAL

- Thank you very much for reading the preview of the manual.
- You can download the complete manual from: www.heydownloads.com by clicking the link below



- Please note: If there is no response to CLICKING the link, please download this PDF first and then click on it.

CLICK HERE TO **DOWNLOAD** THE COMPLETE MANUAL

How to read this manual

JP30ZAE010102002

1. Scope of repair work

- (1) Repair work is classified into three large categories of "Diagnosis", "Mounting/removal, replacement, assembly· disassembly and inspection· adjustment" and "Final inspection".
- (2) This manual describes "Diagnosis" in the first process and "Mounting/removal, replacement, assembly· disassembly and inspection· adjustment" in the second process. Explanation of "Final inspection" in the third process is omitted here.
- (3) Although the following work is not described in this manual, it should be performed in actual work.
 - a. Jacking and lifting
 - b. Cleaning and washing of removed parts as required
 - c. Visual inspection

2. Standard value

- (1) Standard value, limit, action and tightening torque described in the text are summarized in tables.

3. Items to be prepared

- (1) Items to be prepared before work are SST, tools, gauges and lubricant, etc. These are listed in the list section of items to be prepared. Items such as general tools, jack, rigid rack, etc. that are usually equipped in general service shop are omitted.

4. How to read sections and titles

- (1) Sections are classified according to J2008, SAE standard.
- (2) For areas that show system names like "Engine control system", "Inspection", "Adjustment", "Replacement", "Overhaul", etc. of components are described.
- (3) For areas that show part names like "Injection pump", "Mounting/removal and disassembly" is described.
- (4) Illustrations of the parts catalog are shown for part layout. (Part codes in the parts catalog are described in the illustration. Major names and tightening torque are listed in the table.)

⚠ CAUTION • **The part layouts in this manual are inserted based on illustrations and part numbers of the parts catalog CD-ROM issued in February, 2012. (Some areas do not show exploded view. They will be additionally issued when the parts catalog CD is revised.) Be sure to use the parts catalog for confirmation of illustrations and part numbers and for ordering parts.**

Tightening of engine bolts and nuts

JP30ZAE010102003

1. Tightening torque of general standard bolts

(1) For bolts with seatings

Unit : N·m {kgf·cm, lbf·ft}

Screw diameter x Pitch	7T	9T
M8 x 1.25 (Coarse thread)	28.5 {290, 21}	36 {370, 27}
M10 x 1.25 (Fine thread)	60 {610, 44}	74.5 {760, 55}
M10 x 1.5 (Coarse thread)	55 {560, 41}	68.5 {700, 51}
M12 x 1.25 (Fine thread)	108 {1100, 80}	136 {1390, 101}
M12 x 1.75 (Coarse thread)	97 {990, 72}	125 {1280, 93}
M14 x 1.5 (Fine thread)	171.5 {1750, 127}	216 {2210, 160}
M14 x 2 (Coarse thread)	154 {1570, 114}	199 {2030, 147}
Remark	Bolt with number "7" on the head	Bolt with number "9" on the head

⚠ CAUTION • 8T bolt is in accordance with 7T bolt.

(2) For bolts with washers

Unit : N·m {kgf·cm, lbf·ft}

Screw diameter x Pitch	4T	7T	9T
M6 x 1 (Coarse thread)	6 {60, 4}	10 {100, 7}	13 {130, 9}
M8 x 1.25 (Coarse thread)	14 {140, 10}	25 {250, 18}	31 {320, 23}
M10 x 1.25 (Fine thread)	29 {300, 22}	51 {520, 38}	64 {650, 47}
M10 x 1.5 (Coarse thread)	26 {270, 20}	47 {480, 35}	59 {600, 43}
M12 x 1.25 (Fine thread)	54 {550, 40}	93 {950, 69}	118 {1200, 88}
M12 x 1.75 (Coarse thread)	49 {500, 36}	83 {850, 61}	108 {1100, 80}
M14 x 1.5 (Fine thread)	83 {850, 61}	147 {1500, 108}	186 {1900, 137}
M14 x 2 (Coarse thread)	74 {750, 54}	132 {1350, 98}	172 {1750, 127}
Remark	Bolt with number "4" on the head Projection bolt Stud with R surface at free end	Bolt with number "7" on the head Stud with C surface at free end	Bolt with number "9" on the head

⚠ CAUTION • 8T bolt is in accordance with 7T bolt.

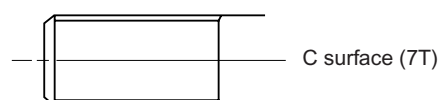
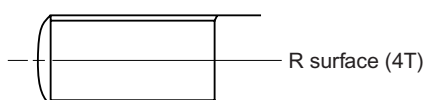

Failure diagnosis using HinoDX

JP30ZAE010301003

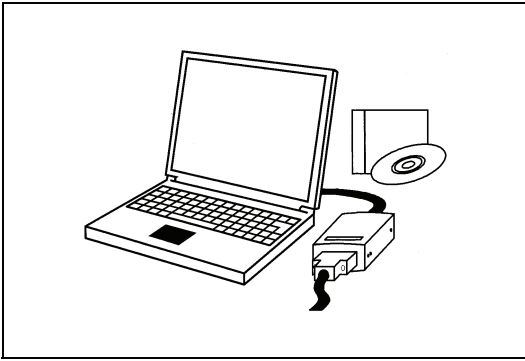

SAPH30ZAE0100029

⚠ CAUTION • HinoDX is used for inspection and adjustment of the system in addition to failure diagnosis.

1. HinoDX

- (1) With HinoDX, failure of the common rail fuel injection system can be diagnosed. The interface box (Hino-Bowie or DST-i) and the special cable are required for connection to the unit.

2. List of failure diagnosis tools

Part name	Part No.	External shape	General description and function
PC (DOS/V standard)	—		<ul style="list-style-type: none"> • Operating system(OS) : Windows95, Windows98(IE5.0 or later), Windows2000(SP3, IE5.0 or later), WindowsXP(SP1a, IE6.0 or later), WindowsVista*2, Windows7*2 • CPU and memory : Conditions that assure operation of the above operating system • Display : 800 x 600, 256 colors or more
Hino Diagnostic eXplorer (HinoDX)	—		<ul style="list-style-type: none"> • Software and CD-ROM <p>NOTICE</p> <ul style="list-style-type: none"> • Install the software of the Hino Diagnostic eXplorer (HinoDX) in the PC. For the installation method, refer to the instruction manual accompanying the CD.
Hino-Bowie	09993 - E9070*1		<ul style="list-style-type: none"> • PC interface <p>⚠ CAUTION</p> <ul style="list-style-type: none"> • It is necessary to update hardware.
	—		<ul style="list-style-type: none"> • The cable between the personal computer and the Hino-Bowie is bundled to the Hino-Bowie. • Please use either RS-232C or USB.

Inspection item		Standard value	Service limit	Action	
Crank- shaft	Crank pin outer diameter	65 {2.5591}	64.3 {2.5315}	Replace*1	
	Crank pin oil clearance	0.031-0.082 {0.0012-0.0032}	0.2 {0.0079}	Replace*1	
	Crank journal outer diameter	80.0 {3.1496}	79.3 {3.1220}	Replace*1	
	Crankshaft oil clearance	0.051-0.102 {0.0020-0.0040}	Repair limit 0.2 {0.0079}	Replace*1	
	Center journal width	36.0 {1.4173}	37.0 {1.4567}	Replace	
	Crankshaft end play	0.270 {0.0106}	Repair limit 0.500 {0.0197} Service limit 1.270 {0.050}	Replace	
	Crankshaft runout	0-0.1 {0-0.0039}	0.15 {0.0059}	Grind*1	
*1 : Correction with re-grinding for eccentric wear of 0.10 mm {0.0039 in.} or more. Re-grinding for wear of 0.20 mm {0.0079 in.} or more. Replace crankshaft for wear of 0.7 {0.0276 in.} mm or more.					
Connecting rod end play		0.20-0.52 {0.0079-0.0204}	1.0 {0.03937}	Replace	
Cam- shaft	Camshaft journal outer diameter		40 {1.5748}	39.85 {1.5689}	Replace
	Camshaft bearing inner diameter		40 {1.5748}	40.15 {1.5807}	Replace
	Camshaft bearing oil Clearance		0.020-0.063 {0.0008-0.0024}	—	Replace
	Cam height	IN	50.067 {1.9711}	49.987 {1.9680}	Replace
		EX	52.104 {2.0513}	52.024 {2.0482}	
	Cam lift	IN	8.067 {0.3176}	(7.987 {0.3144})	Replace
		EX	10.104 {0.3978}	(10.024 {0.3946})	
	Camshaft journal width (Rear journal)		33 {1.2992}	—	
	Camshaft end play		0.100-0.178 {0.0039-0.0070}	—	Replace
Camshaft runout		0.04 {0.0016}	0.1 {0.0039}	Replace	
Rocker shaft outer diameter		22 {0.8661}	21.92 {0.8630}	Replace	
Rocker arm bushing inner diameter		22 {0.8661}	22.08 {0.8693}	Replace	
Rocker arm oil clearance		0.030-0.101 {0.0012-0.0039}	0.15 {0.0059}	Replace	
Valve stem outer diameter	IN	7 {0.2755}	—	Replace	
	EX	7 {0.2755}	—		
Valve guide inner diameter	IN	7 {0.2755}	—	Replace	
	EX	7 {0.2755}	—		

3 PARTS TO BE PREPARED

Engine Mounting/Dismounting	3-2
Special tool	3-2
Fuel System	3-2
Special tool.	3-2
Emission control	3-2
Lubricant, etc.	3-2
Electrical.....	3-3
Special tool	3-3
Engine Mechanical	3-3
Special tool	3-3
Gauge	3-6
Lubricant, etc.	3-6
Exhaust.....	3-7
Lubricant, etc.	3-7
Lubrication	3-8
Special tool	3-8
Lubricant, etc.	3-8
Starting and Charging.....	3-9
Jig (reference dimensional drawing for manufacture)	3-9
Gauge	3-9
Lubricant, etc.	3-10
Turbocharger.....	3-10
Special tool	3-10
Engine Failure Diagnosis.....	3-10
Special tool	3-10

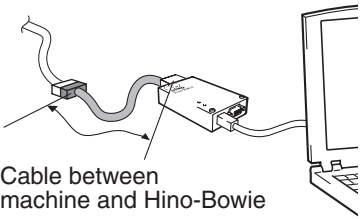
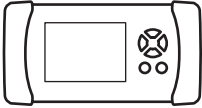
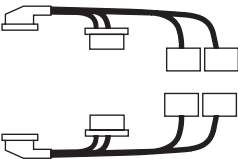
Shape	Part No.	Name	Remark
 <p>Cable between machine and Hino-Bowie</p>	S0904-21220 (09042-1220)	Connecting cable	Cable for diagnostic connecting to the machine side.
	DENSO DST-i set		Computer interface
	95171-01020	without LCD without Bluetooth®	
	95171-01040	without LCD with Bluetooth®	
	95171-01030	with LCD without Bluetooth®	
	09843-E4050	Signal check harness	This is installed as interruption between machine harness and the ECU. Tester inspection is allowed in energized status.

*1: To use Hino-Bowie (interface box) 09993-E9070, update the hardware. For details, refer to the user's manual in the HinoDX CD-ROM.

Keep updating the firmware (software built in the Hino-Bowie) using the software in the HinoDX CD-ROM. For details, refer to the user's manual in the HinoDX CD-ROM.

*2: HinoDX (Ver. 3.0.5 or later), only when use DST-i.

5 FUEL SYSTEM

Fuel system	5-2
Fuel system diagram.....	5-2
Part layout.....	5-3
Fuel filter element	
(with water cup without harness, machine mount) .	5-5
Part layout.....	5-5
Water draining.....	5-6
Replacing the fuel filter element.....	5-8
Fuel filter (Engine side).....	5-10
Replacement.....	5-10
Supply Pump.....	5-13
Part layout.....	5-13
Replacement.....	5-14
Injector.....	5-23
Part layout.....	5-23
Replacement.....	5-24
Common rail.....	5-32
Part layout.....	5-32
Inspection	5-33
Replacement.....	5-34

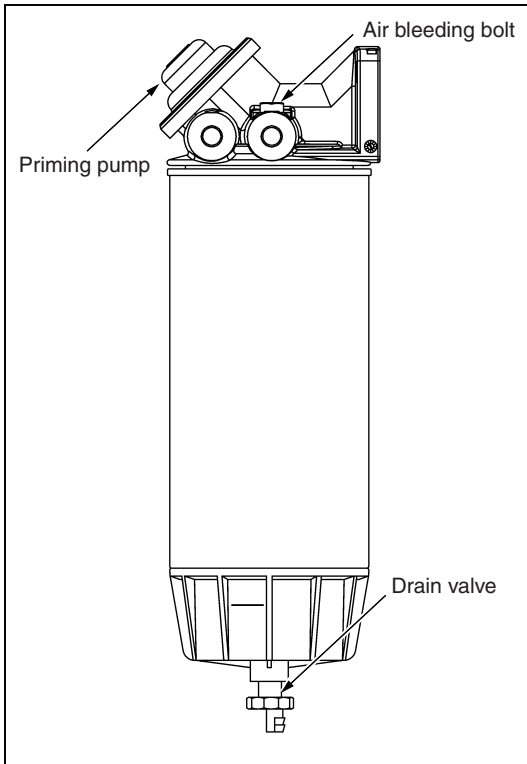

2. Fuel discharging

- (1) Prepare a container under the drain pipe of the machine side fuel filter.
- (2) Loosen the drain valve next loosen the air bleeding valve at the machine side fuel filter. Discharge fuel from the drain valve.
Confirm that fuel has stopped coming out from the drain valve and tighten the drain valve.

- ⚠ CAUTION**
- To dispose fuel, observe the specified method (waste disposal) or the method with attention to environment.
 - Make sure that the drain plug is not damage or corrosion.

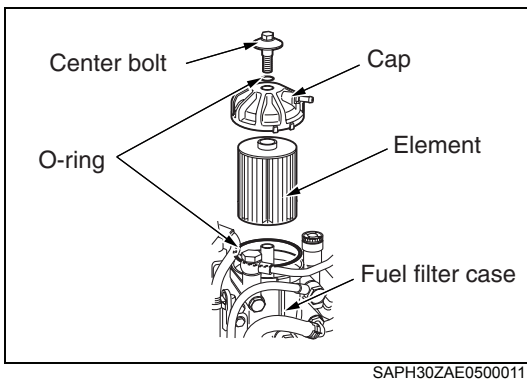

3. Removal of the element

- (1) Remove the center bolt, and remove the O-rings (2 pcs.) and caps from the engine side fuel filter case.
- (2) Remove the element.

- ⚠ CAUTION**
- When draining the fuel, drain all fuel from inside the filter. When the element is replaced without draining all fuel, there is the possibility that unfiltered fuel remains in the filter and flows to the engine side.
 - Prepare a container for catching dripped fuel from the filter that the fuel remains in the case.

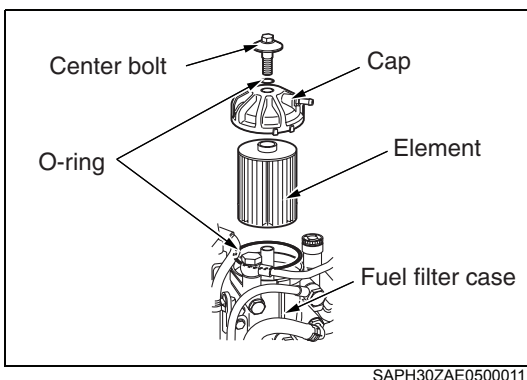

4. Installation of the element

- (1) Replace the O-ring with new ones at air bleeding plug and drain plug.
- (2) Remove any dust around the fuel filter case inside and the element fitting point of the cap inside.
- (3) Install a new element in to the fuel filter case.

- ⚠ CAUTION**
- When the element is replaced without draining all fuel from the fuel filter case, unfiltered fuel remains in the fuel filter case; make sure that the filter case does not contain any remaining fuel.

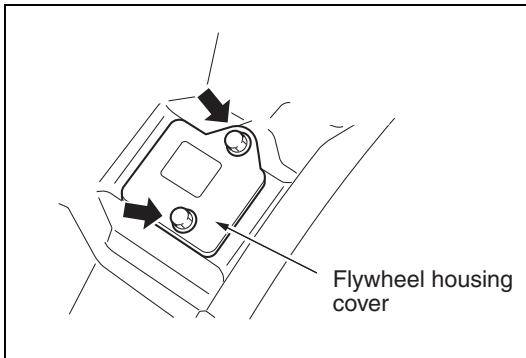

SAPH30ZAE0500016

- (4) Mount the flywheel housing cover to the flywheel housing with the bolts (2 pcs.).

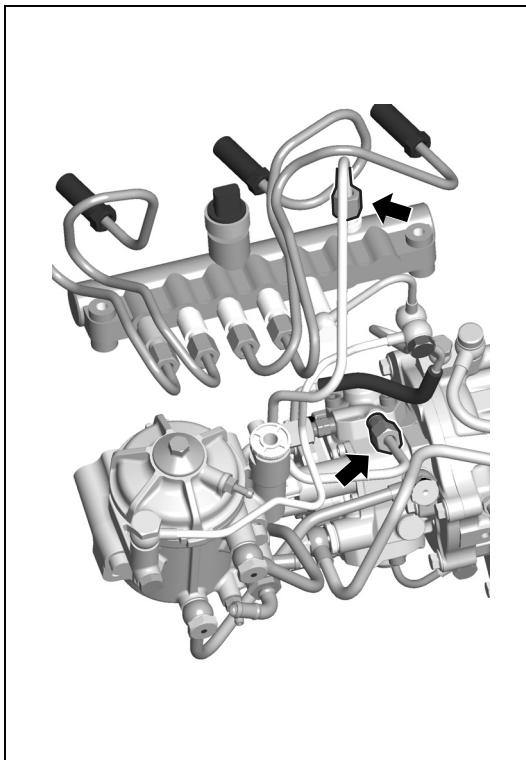

SAPH30ZAE0500015

5. Mounting the pressure feed pipe

- (1) Install the new pressure feed pipe to the supply pump and commonrail.

Tightening torque:

44 N·m {450 kgf·cm, 33 lbf·ft}

- ! CAUTION** • Always replace the pressure feed pipe by a new one because the pipe is subjected to high pressure; reusing the same pipe may result in a fuel leak.

- (2) Mount the clips (2 pcs.) with the nuts (2 pcs.) and fix the pressure feed pipe.

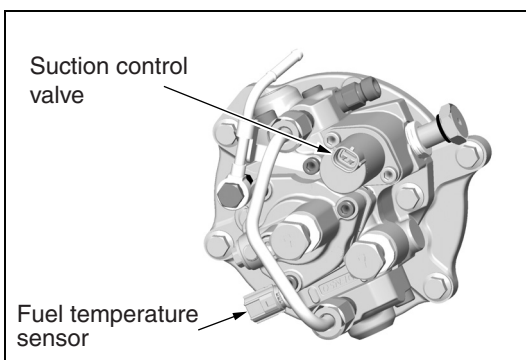

SAPH30ZAE0500014

6. Connecting the harness

- (1) Connect the connector to the fuel temperature sensor and suction control valve of the supply pump.

- ! CAUTION** • Before connecting the connectors, make sure that the terminals are free of a spark mark.

7. Mounting the fuel filter case

8. Air bleeding of fuel system

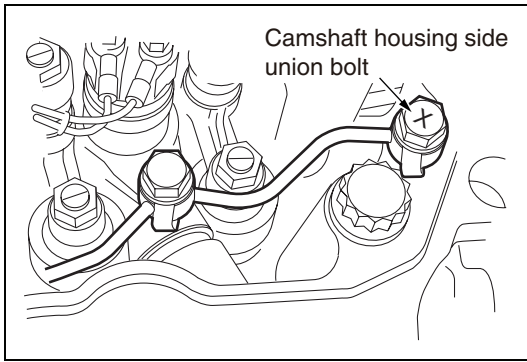

SAPH30ZAE0500046

- There is the "X" mark at the union bolt of the camshaft housing.

5. Installation of the head cover

6. Air bleeding of the fuel system

Inspection

1. Inspection before servicing

- (1) Using the HinoDX for operation check of the air flow sensor.
- (2) Using the HinoDX for operation check of the EGR valve on board.
(Refer to the Hino-DX user's manual.)

Replacement

JP30ZEE060704001

Replacement of EGR valve & cooler

1. CAUTIONS

- ⚠ CAUTION** • Perform replacement after cooling to prevent burns. (Turn the starter key to the "LOCK" position and leave it for more than 30 minutes to cool.)

2. Draining the coolant

- (1) Drain the coolant.

3. Removing the EGR pipe

- (1) Remove the engine harness from 2 brackets.
- (2) Unfasten the 3 bolts and nut to remove 2 brackets from the EGR pipe.

- ⚠ CAUTION** • Do not touch the EGR pipe with bare hands while it is hot immediately after running.

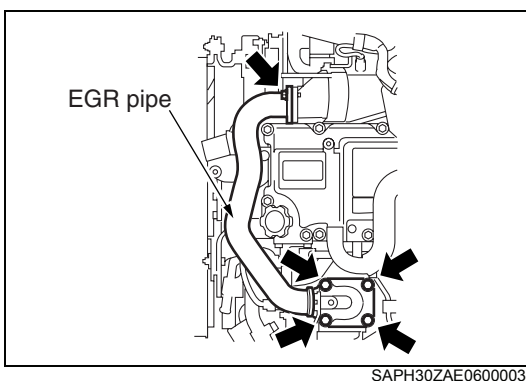
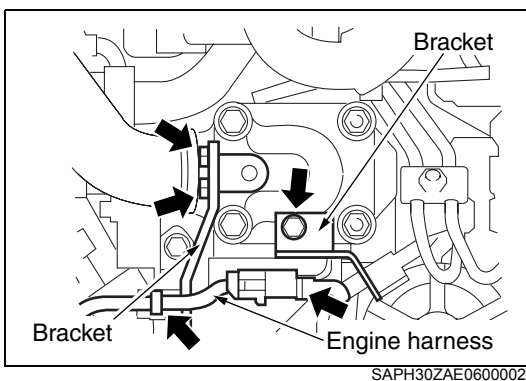

- (3) Unfasten the 4 bolts and 2 nuts to remove the EGR pipe and 2 gaskets.

JP31199070402002

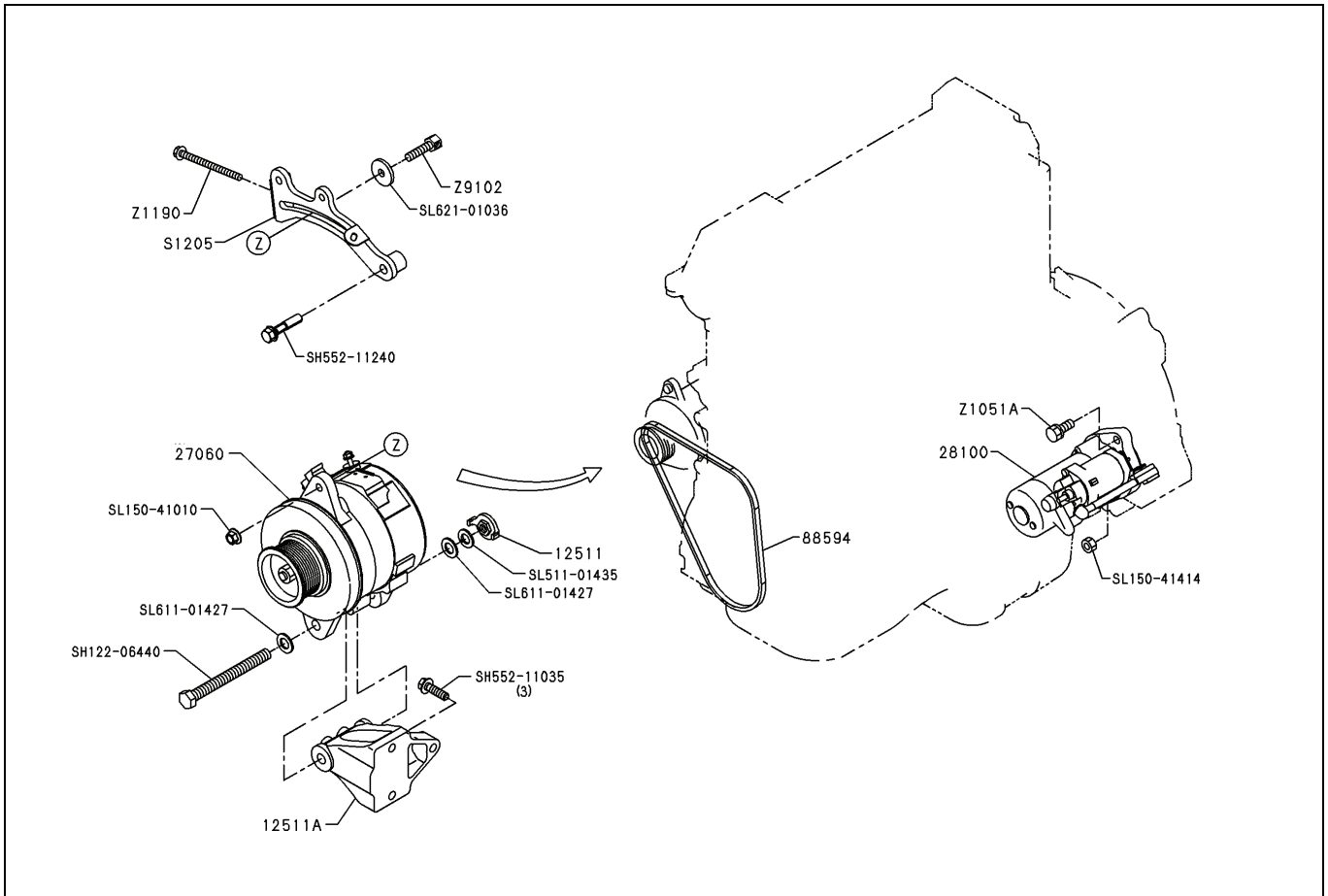

SAPH30ZAE0700002

12511A	Alternator bracket	S1205	Alternator brace
27060	Alternator assembly	SH122-06440	Through bolt
28100	Starter assembly	Z1190	Adjusting bolt
89594	V-belt	Z9102	Fixing bolt brace side

Tightening torque

Z1051A	154N· m{1,570kgf· cm, 113 lbf· ft}	SL150-41414	154N· m{1,570kgf· cm, 113 lbf· ft}
Z1190	5.9N· m{60kgf· cm, 4 lbf· ft}	SH122-06440	83N· m{850kgf· cm, 61 lbf· ft}
SL150-41010	51N· m{520kgf· cm, 38 lbf· ft}		

Replacement of the Engine ECU

JP3032J070702001

Removing the engine ECU connector

- ⚠ CAUTION** • Before replacement, wait until the engine cools down as you may get burned. (Turn the starter key to the "LOCK" position and leave it for more than 30 minutes to cool.)

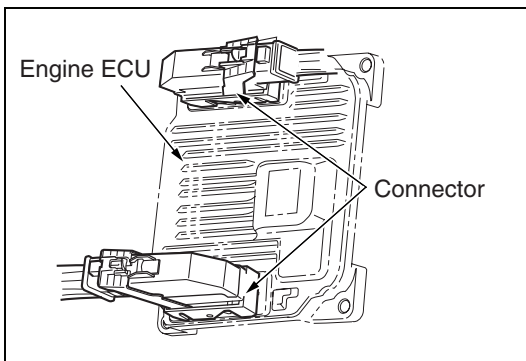

SAPH30ZAE0700018

1. Cleaning the engine ECU connector

- (1) Check that the engine ECU connector is completely connected to the engine ECU.
- (2) Check that the engine ECU connector is completely connected to the engine ECU.

- ⚠ CAUTION** • Do not remove the connector while at work.

- NOTICE** • If it is much dirty, squirt water at the connector sliding portion and connector surface.

- (3) Blow air around the engine ECU connector and engine ECU surface to remove dirt and foreign matter.

- ⚠ CAUTION** • Do not remove the connector while at work.
• Blow off water with air as much as possible for drying.

- (4) Using a small brush, carefully remove dirt and foreign matter remaining at the sliding portion.

- ⚠ CAUTION** • Do not remove the connector while at work.

- (5) Using a waste cloth, wipe off around the engine ECU connector and engine ECU surface.

- ⚠ CAUTION** • Do not remove the connector while at work.
• Wipe up water thoroughly.

- (6) If you feel the movement of the lever unsmooth, repeat steps (1), (2), (3), (4) and (5).

- (7) Disconnect the engine ECU connector and check it for deposition of dirt and foreign matter.

- a. Set the hook of the connector in the direction of the arrow to release the lock.

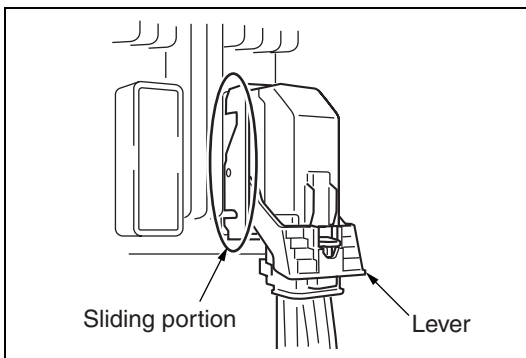

SAPH30ZAE0700019

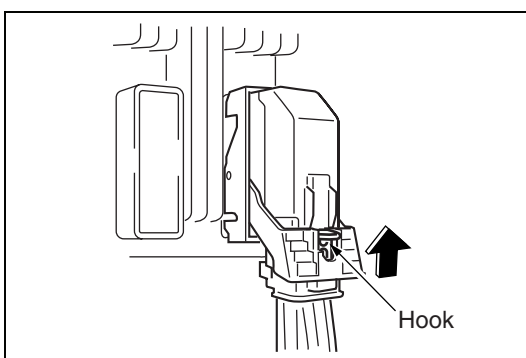

SAPH30ZAE0700020

Replacement

JP31ZAJ080704003

Removal of the intake throttle valve

1. Removal of the intake throttle valve

- (1) Remove the bolts (2pcs.) and nuts (2pcs.) remove the intake throttle valve and gasket from the intake pipe.

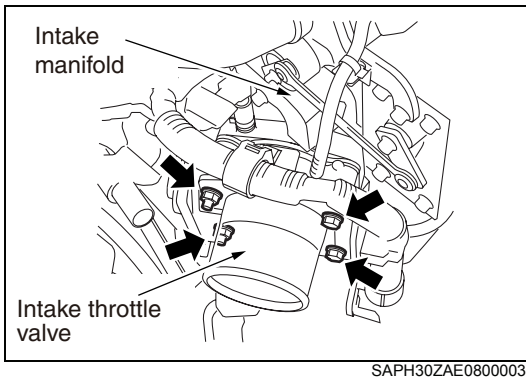

2. Disconnection of the harness wire

- (1) Disconnect the connector from the intake throttle valve.

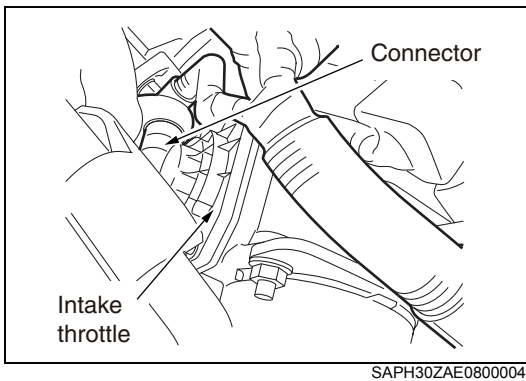

Installation of the intake throttle valve

1. Connection of the intake throttle valve

- (1) Connect the connector to the intake throttle valve.

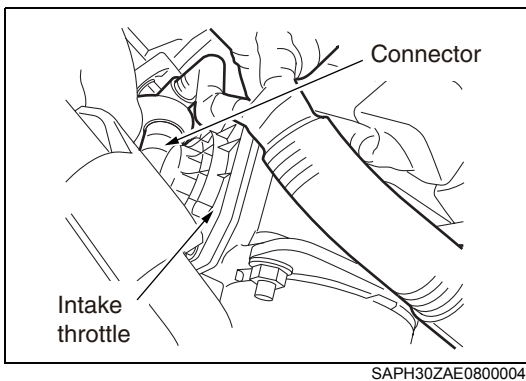

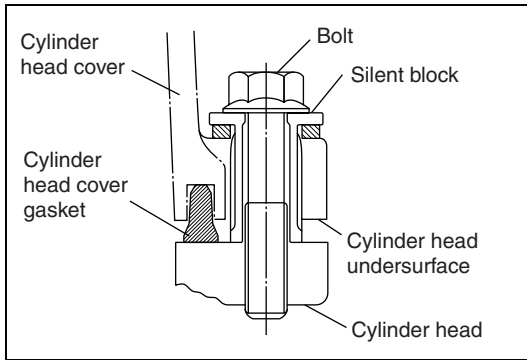

SAPH30ZAE0900019

- (4) Put the cylinder head cover on the cylinder head and tighten bolts.

Tightening torque: 28.5 N·m {290 kgf·cm, 21 lbf·ft}

- NOTICE**
- Rubber spacers are attached to the silent block.

Overhaul of cylinder head

JP31ZAJ090702001

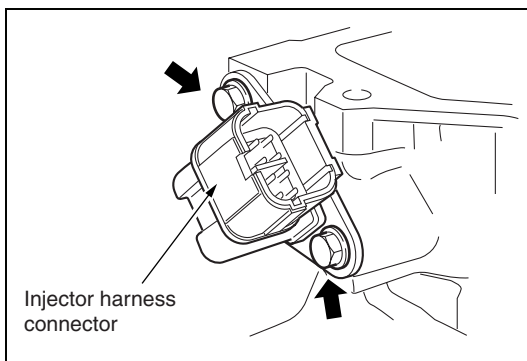

SAPH30ZAE0900020

1. Removing the injector harness connector

- (1) Unfastening the 2 bolts to remove the injector harness connector from the cylinder head.

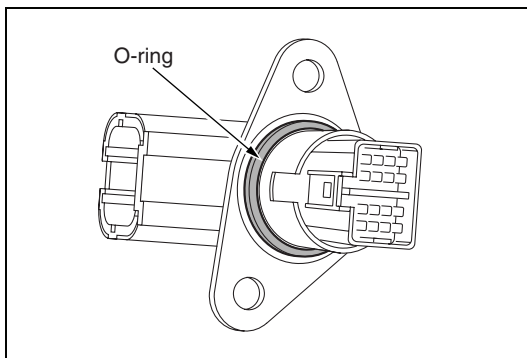

SAPH30ZAE0900021

- (2) Removing the O-ring from the injector harness connector.

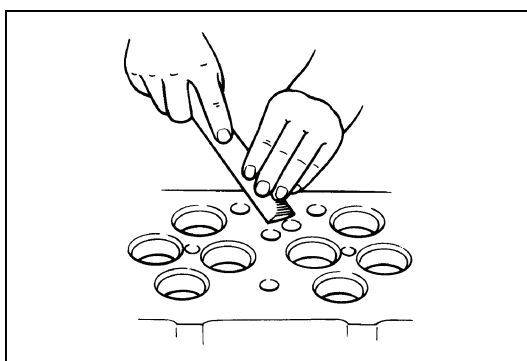

SAPH30ZAE0900022

2. Cleaning the cylinder head

- (1) Using the scraper to remove carbon and other adherents.
 (2) Washing the cylinder head.

- CAUTION**
- When removing carbon and other adherents, do not damage the bottom surface of the cylinder head.

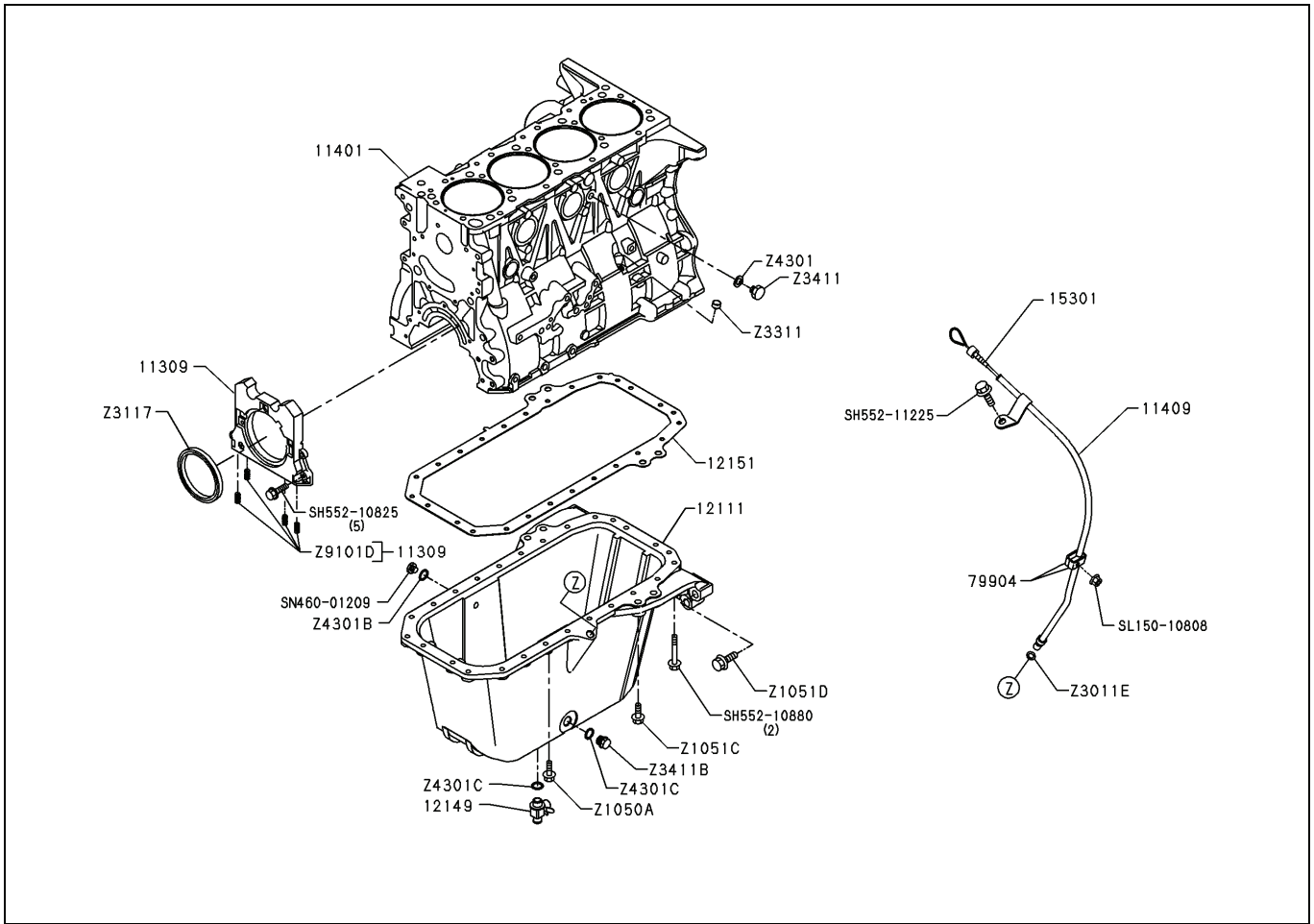

SAPH30ZAE0900048

11309	Front oil seal retainer	Z3117	Front oil seal*
11401	Cylinder block		

*Parts not to be reused.

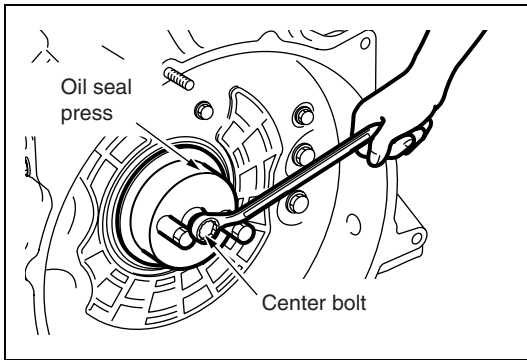

SAPH30ZAE0900074

- (7) Attaching the accompanying center bolt to the oil seal press and tighten it until it stops to press-fit the crankshaft rear oil seal.

CAUTION • Press-fit evenly around the circumference.

- (8) Tightening the center bolt until the press comes in contact and check that the oil seal is press-fit evenly around the circumference.

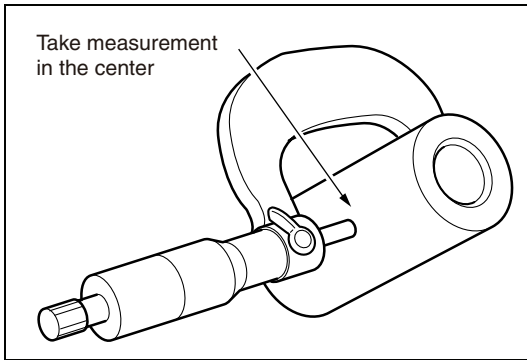

SAPH30ZAE0900101

6. Inspecting the piston pin and connecting rod bush

- (1) Using the micrometer to measure the outer diameter of the piston pin center. If a measurement reading exceeds the operation limit, replace the piston pin.

Standard value (mm {in.})	Operation limit (mm {in.})
37 {1.457}	36.96 {1.455}

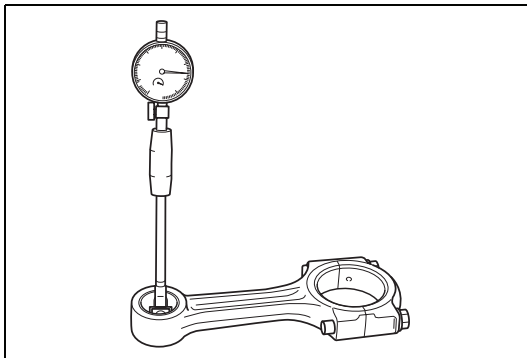

SAPH30ZAE0900102

- (2) Using the cylinder gauge to measure the inner diameter of the connecting rod bush. If a measurement reading exceeds the Operation limit, replace the bush.

Standard value (mm {in.})	Operation limit (mm {in.})
37 {1.457}	37.1 {1.461}

- (3) Calculating the gap between the outer diameter of the piston pin center and the inner diameter of the connecting rod bush. If a calculated value exceeds the operation limit, replace the connecting rod bush.

Standard value (mm {in.})	Operation limit (mm {in.})
0.035-0.056 {0.0014-0.0022}	0.08 {0.0032}

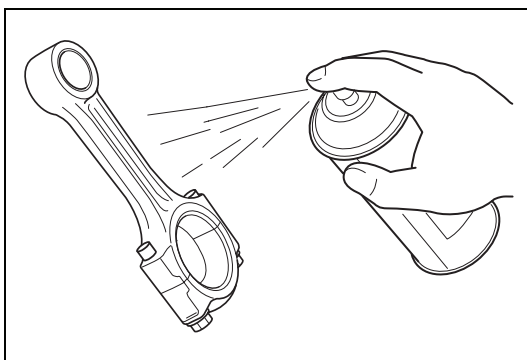

SAPH30ZAE0900103

7. Inspecting the connecting rod

- (1) Using the dye penetrant testing (red check) to inspect the connecting rod for crack and damage. If found defective, replace the connecting rod.

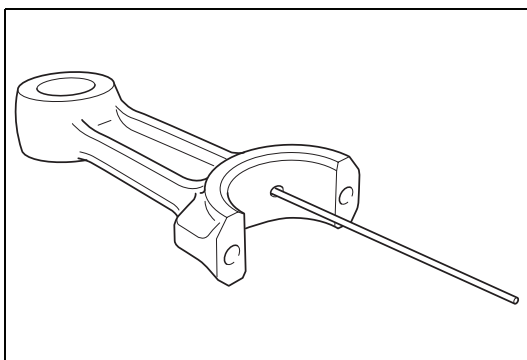

SAPH30ZAE0900104

- (2) Inserting the bar of 4 mm {0.1575 in.} in diameter into an oil hole in the large end of the connecting rod and check if the bar goes through the oil hole to the small end. If clogging in the oil hole prevents the bar of 4 mm {0.1575 in.} in diameter from going through, replace the connecting rod.

! CAUTION • Clogging in the oil hole may cause insufficient oiling, resulting in seizure.

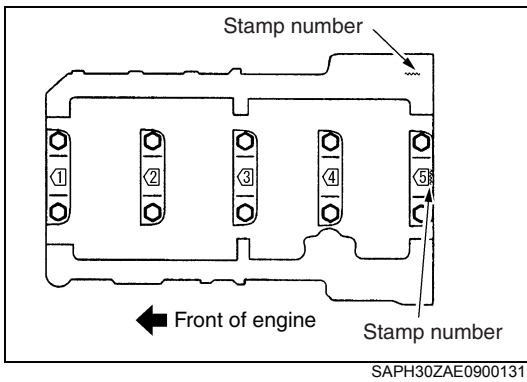

- (6) Setting the main bearing cap mounted with the thrust bearing and main bearing to the cylinder block.

- CAUTION**
- Making sure that the pentagon-shaped marks indicated on the main bearing caps face to the engine front side in the order of 1-5 from front to back.
 - Checking the engraving No. on the main bearing cap against the engraving No. on the cylinder block.

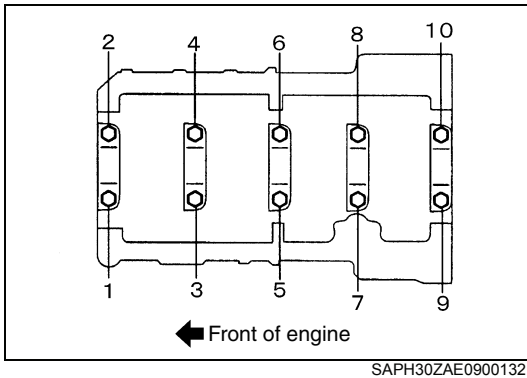

- (7) Applying engine oil to bolt seat surfaces and threads of the bearing cap bolts.
- (8) Tightening the bearing cap bolts in order as shown in the figure.
- Tightening torque: 69 N·m {700 kgf·cm, 51 lbf·ft}**
- (9) Loosening the bearing cap mounted with the thrust bearing and use the plastic hammer to tap the crankshaft at its front and back ends.

- (10) Loosening the all the bearing cap bolts.
- (11) Tightening the bearing cap bolt as in the above.
- Tightening torque: 69 N·m {700 kgf·cm, 51 lbf·ft}**
- (12) Using the paint to mark the bearing cap bolt heads in the same direction.
- (13) Tightening the bolts by 90° (1/4 turns) in the same order as in the above.
- (14) Retightening the bolts by another 45° (1/8 turns) in the same order as in the above.
- (15) Checking that all the paint markings face the same direction.

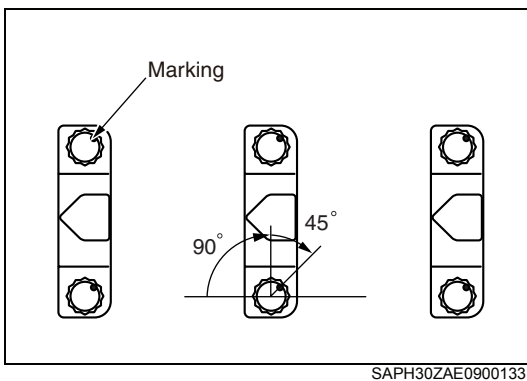

- CAUTION**
- Do not loosen the bolt even when it is over tightened during retightening.
- (16) After completion of tightening, tap the front and back ends of the crankshaft with the plastic hammer so that crankshaft fits the assembly.

- CAUTION**
- Do not loosen the bolt even when it is over tightened during retightening.
 - Do not loosen the bolt even when it is over tightened during retightening.

Standard value (mm {in.})	Repair limit (mm {in.})	Operation limit (mm {in.})
0.050-0.270 {0.0020-0.0106}	0.500 {0.0197}	1.270 {0.05}

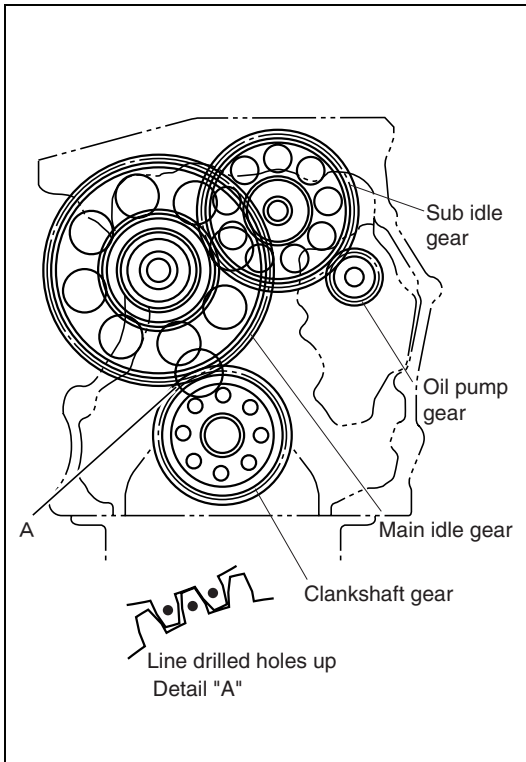

- (3) After applying engine oil to the seating surface and threads of the idle gear shaft mounting bolt, orient an oil hole in the idle gear shaft to the oil pan (downward direction) and synchronize timing between the crankshaft gear and the main idle gear as shown "A" before installation.

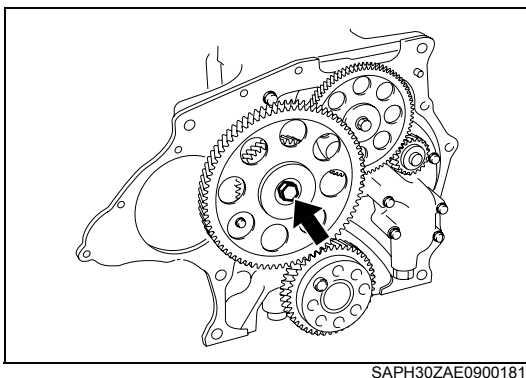

- (4) Apply engine oil to the seating surface and bolt threads of the main idle gear shaft.
- (5) Fastening the main idle gear shaft mounting bolt.
Tightening torque: 172 N·m {1,750 kgf·cm, 127 lbf·ft}
- (6) Measure the backlash or end play of each idle gear.
Check that measurement values are within the standard value.
Refer to "Backlash, end play"

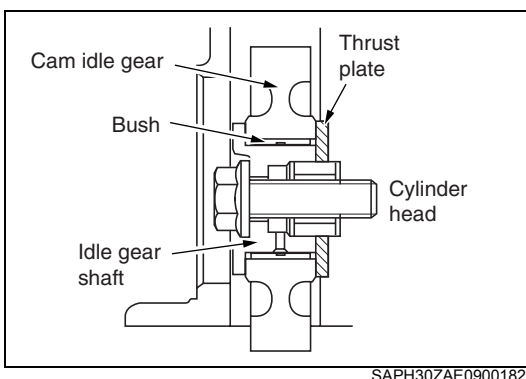

3. Mounting the camshaft cam idle gear

- (1) After applying engine oil to the thrust plate, cam idle gear bush, idle gear shaft and the seating surface and bolt threads of the idle gear shaft, orient an oil hole in the idle gear shaft to the downward direction and assemble them as shown in the figure.

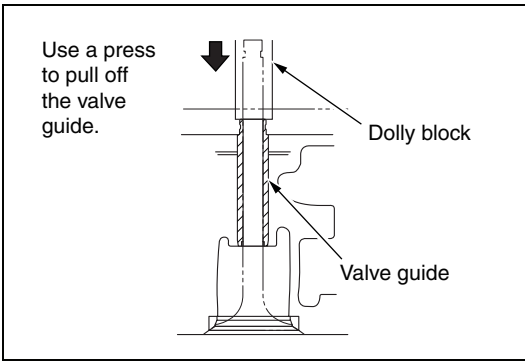

SAPH30ZAE0900206

5. Removing the valve guide

- (1) Using the dolly block or press to pull off the valve guide.

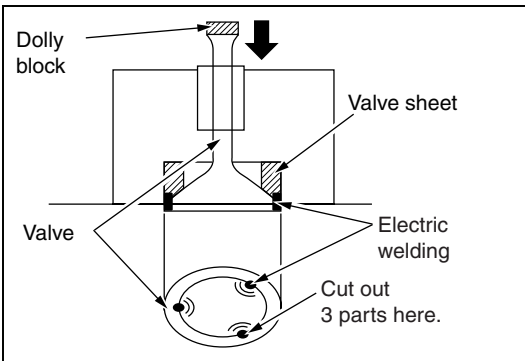

SAPH30ZAE0900207

6. Removing the valve seat

⚠ CAUTION • Replacing the valve seat in the following procedure may damage the cylinder head. For secure replacement, we recommend you to ask a machine processor.

- (1) Using the unnecessary valve to replace the valve seat. After cutting out three parts from the valve periphery, weld to the valve seat.

⚠ CAUTION • Before welding, apply grease to the bottom surface of the cylinder head to protect from spatter.

- (2) Placing the dolly block (such as a brass bar) to the valve stem head and pull off the valve seat by using the press.

Inspecting the components

1. Inspecting the valve and valve seat

- (1) Using the straightedge and thickness gauge to measure the valve sink. If a measurement reading exceeds the operation limit, replace the valve and valve seat.

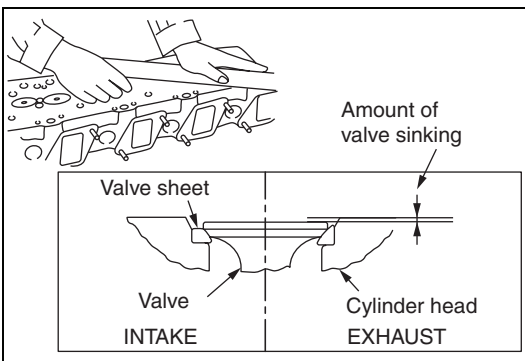

SAPH30ZAE0900208

Measured item	Standard value (mm {in.})	Operation limit (mm {in.})
Intake	0.55-0.85 {0.0217-0.0335}	1.1 {0.0433}
Exhaust	1.15-1.45 {0.0452-0.0571}	1.7 {0.0669}

10 EXHAUST

Exhaust Manifold.....	10-2
Part layout.....	10-2
Replacement.....	10-3
DPR cleaner	10-6
Part layout.....	10-6
Overhaul	10-7
Inspection	10-16
Replacement of DPR filter	10-29

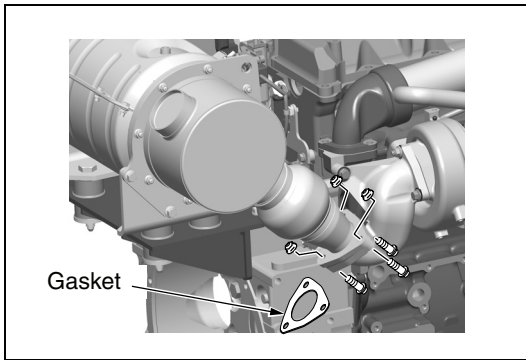

- (6) Replace the gasket by a new one and provisionally secure the flange part with bolts (the 2 upper ones) to the engine body.

CAUTION • In order to minimize flexible pipe deformation, keep the provisional tightening within approximately two or three threads.

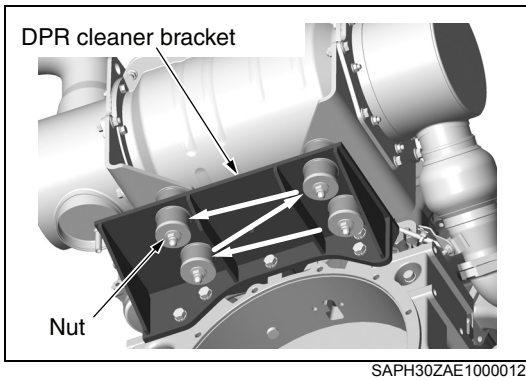

- (7) Securely tighten the nuts (4pcs.) on the lower side of the DPR cleaner bracket from the exhaust inlet side as shown.

Tightening torque : 51 N·m {520 kgf·cm, 38 lbf·ft}

CAUTION • Rotate the nuts one by one for 1 to 1.5 turns so that the projecting part of the rubber does not get disengaged, and perform final tightening after tightening the entire body in several steps.

- After tightening, confirm that the rubber is in close contact with the bracket.

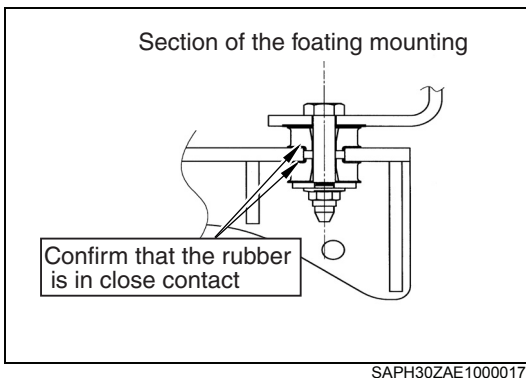

- (8) After provisionally tightening the bolt on the lower side of the flange, tighten it well, together with the bolts (2pcs.) previously tightened securely.

Tightening torque : 59 N·m {602 kgf·cm, 44 lbf·ft}

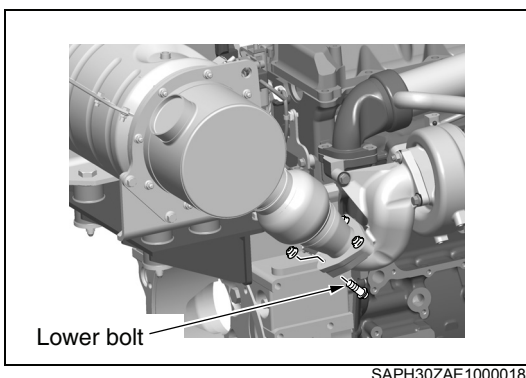

Determination by way of DPR state determination monitor of Hino DX

1. Check that the DTC code comes on.
2. Connect Hino DX.
3. Check past faults.
 - (1) Check past faults by way of Hino DX. In case a general engine fault such as a trouble of an exhaust control system is displayed, inspect and repair the pertinent section.
 - (2) Inspect and repair general engine faults and check past faults again. In case a code indicating a sensor system trouble is displayed, inspect and replace the sensor circuit.

Inspection item	DTC code
Front DPR exhaust temperature sensor trouble	P0545, P0546
Rear DPR exhaust temperature sensor trouble	P2032, P2033
DPR backpressure sensor trouble	P1427, P1428

- (3) Check past faults. In case DPR trouble (DTC code: P200C, P244A, P2463, P244B, P2458, P24A2) is displayed, check the DPR state monitor.

11 COOLING

Cooling system.....	11-2
Cooling system drawing.....	11-2
Part layout.....	11-3
Replacement of cooling fan and fan clutch.....	11-4
Replacement of thermostat and thermostat case	11-6
Inspection of the thermostat	11-9
Replacement of coolant pump	11-10

CLICK HERE TO **DOWNLOAD** THE COMPLETE MANUAL

- Thank you very much for reading the preview of the manual.
- You can download the complete manual from: www.heydownloads.com by clicking the link below



- Please note: If there is no response to CLICKING the link, please download this PDF first and then click on it.

CLICK HERE TO **DOWNLOAD** THE COMPLETE MANUAL

12 LUBRICATION

Oil Cooler, Oil Filter and Oil Pump.....	12-2
System drawing	12-2
Part layout.....	12-3
Overhauling the oil cooler	12-5
Overhauling the oil pump	12-10
Replacement of the oil strainer	12-17
Oil Pan	12-18
Part layout.....	12-18
Replacement.....	12-19
Inspection of lubrication status	12-21

Inspecting the components

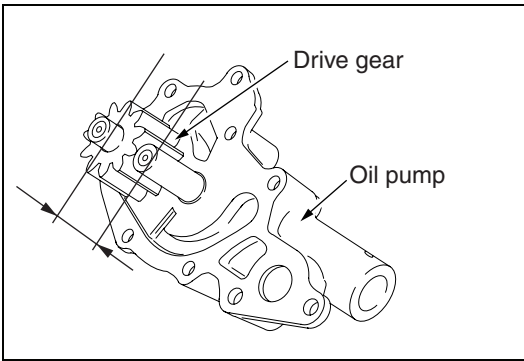

SAPH30ZAE1200017

1. Inspecting the end play of the drive gear and cylinder block

- (1) Using the depth gauge, measure the drive gear width.

Measured item	Standard value (mm {in.})
Width of drive gear	28.5 {1.122}

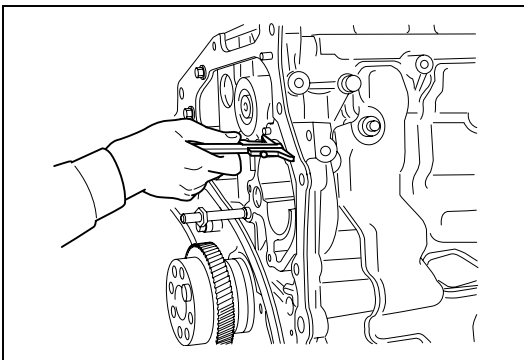

SAPH30ZAE1200018

- (2) Using the depth gauge, measure the pump chamber depth on the cylinder block side.

Measured item	Standard value (mm {in.})
Depth of pump chamber at cylinder block	28.5 {1.122}

- (3) Calculate the difference between the drive gear width and pump chamber depth on the cylinder block side. If exceeding the operation limit, replace the oil pump.

Standard value (mm {in.})	Operation limit (mm {in.})
0.047-0.150 {0.0019-0.0060}	0.15 {0.0060}

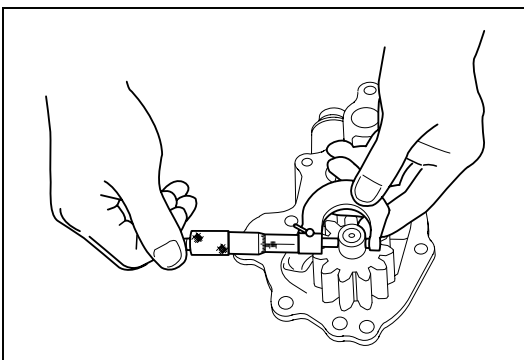

SAPH30ZAE1200019

2. Inspecting the clearance between the drive gear shaft outer diameter and bushing inner diameter on the cylinder block side

- (1) Using the micrometer, measure the drive gear shaft outer diameter.

Measured item	Standard value (mm {in.})
Outer diameter of drive gear shaft	18.0 {0.709}

Inspection of lubrication status

JP31ZAJ120703001

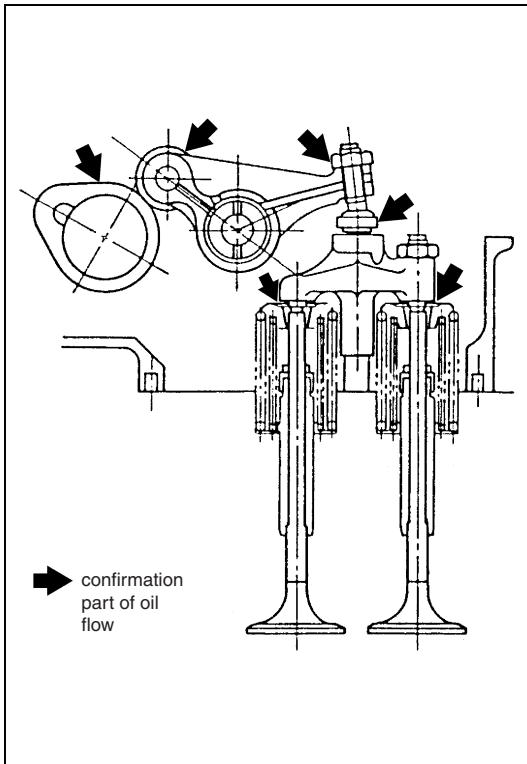

1. Inspection of valve system

CAUTION • Perform inspection with the water temperature at 60° C{140° F}.

(1) Remove the head cover.

CAUTION • To prevent spread of engine oil, attach a jig which cuts a head cover in half. Cut it to the degree that the camshaft is covered.

(2) Adjust the engine revolution to the standard idling revolution [1,000/min{rpm}].

(3) After start of the engine, make sure that oil is supplied to the areas below of all rocker arms within about 10 seconds.

- Roller and cam surface
- Cross head and spring upper seat surface through adjusting screw

CAUTION • If time until lubrication is long or if lubrication is not performed, the oil pressure may be low or the oil channel may be clogged. Seizure, abnormal wear or abnormal noise may occur due to insufficient lubrication.

Inspection of components

JP30ZCE130703001

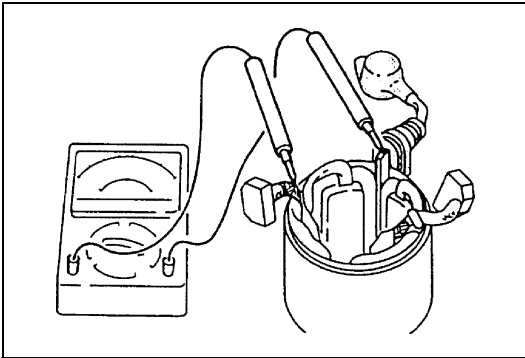

SAPH30ZAE1300024

1. Inspection of yoke assembly

- (1) Make sure that the coil lead wire has electric continuity using a circuit tester.
- (2) Make sure that there is no discoloration at the coil.

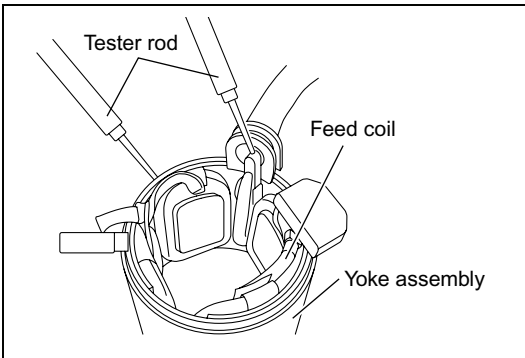

SAPH30ZAE1300025

- (3) Measure the resistance between the coil lead wire and the yoke with a circuit tester and check insulation. When the value is below the service limit, replace it.

Service limit	1kΩ or less
----------------------	--------------------

⚠ CAUTION • After cleaning and drying, take measurements.

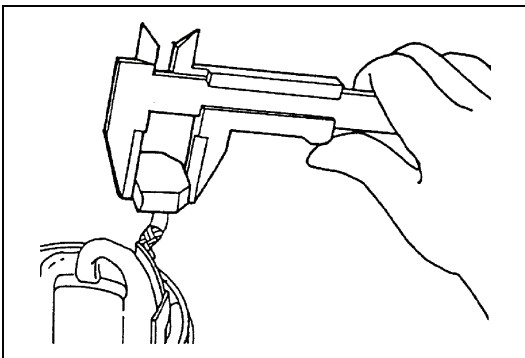

SAPH30ZAE1300026

- (4) Measure the brush length using vernier calipers. When the value is below the service limit, replace it.

Standard value (mm{in.})	Service limit (mm{in.})
18{0.7087}	13{0.5118} or less

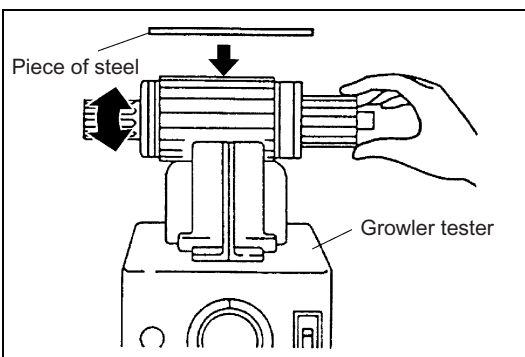

SAPH30ZAE1300027

2. Inspection of armature assembly

- (1) Turn the armature assembly using a commercially available growler tester and put a piece of steel on the armature assembly. Make sure that the steel piece is not vibrating on the core circumference.

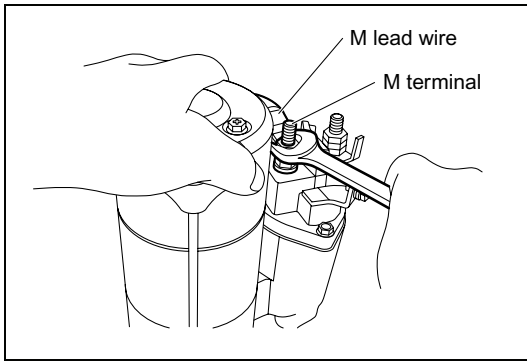

SAPH30ZAE1300002

18. Installation of lead wire

- (1) Install the M lead wire.

19. Lubrication

Refer to the following figure and table for lubricant to be applied.

⚠ CAUTION • There shall be no lubricant on the commutator surface, brush and contact.

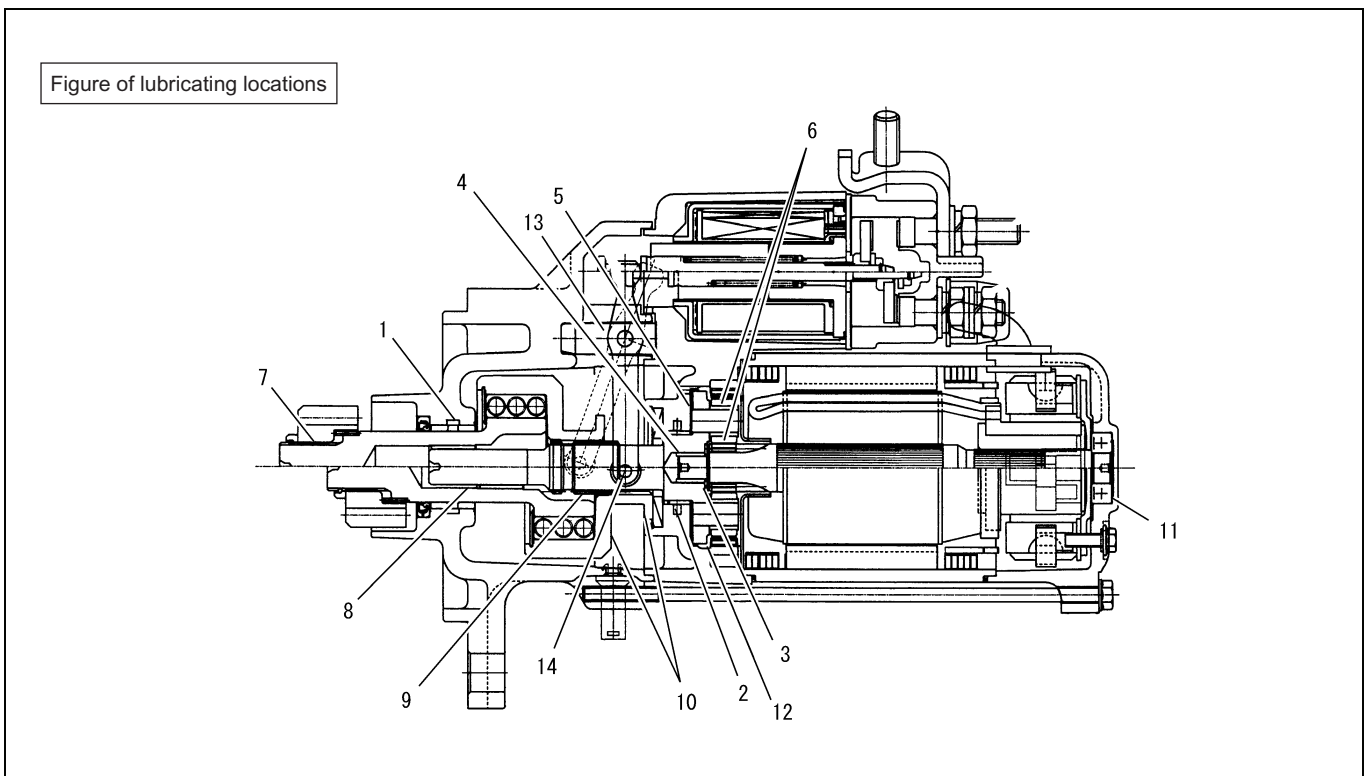

SAPH30ZAE1300046

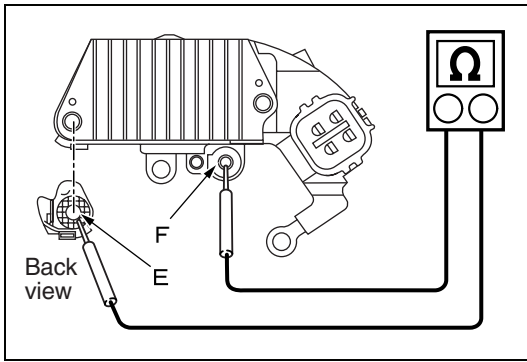

- (2) Measure the resistance between the terminals F - E of the regulator using a circuit tester, if value exceed the standard value, replace it.

Measuring direction	Standard value
Forward resistance value	Approx. 10 Ω
Reverse resistance value	Infinite

CAUTION • Do not use a digital tester.

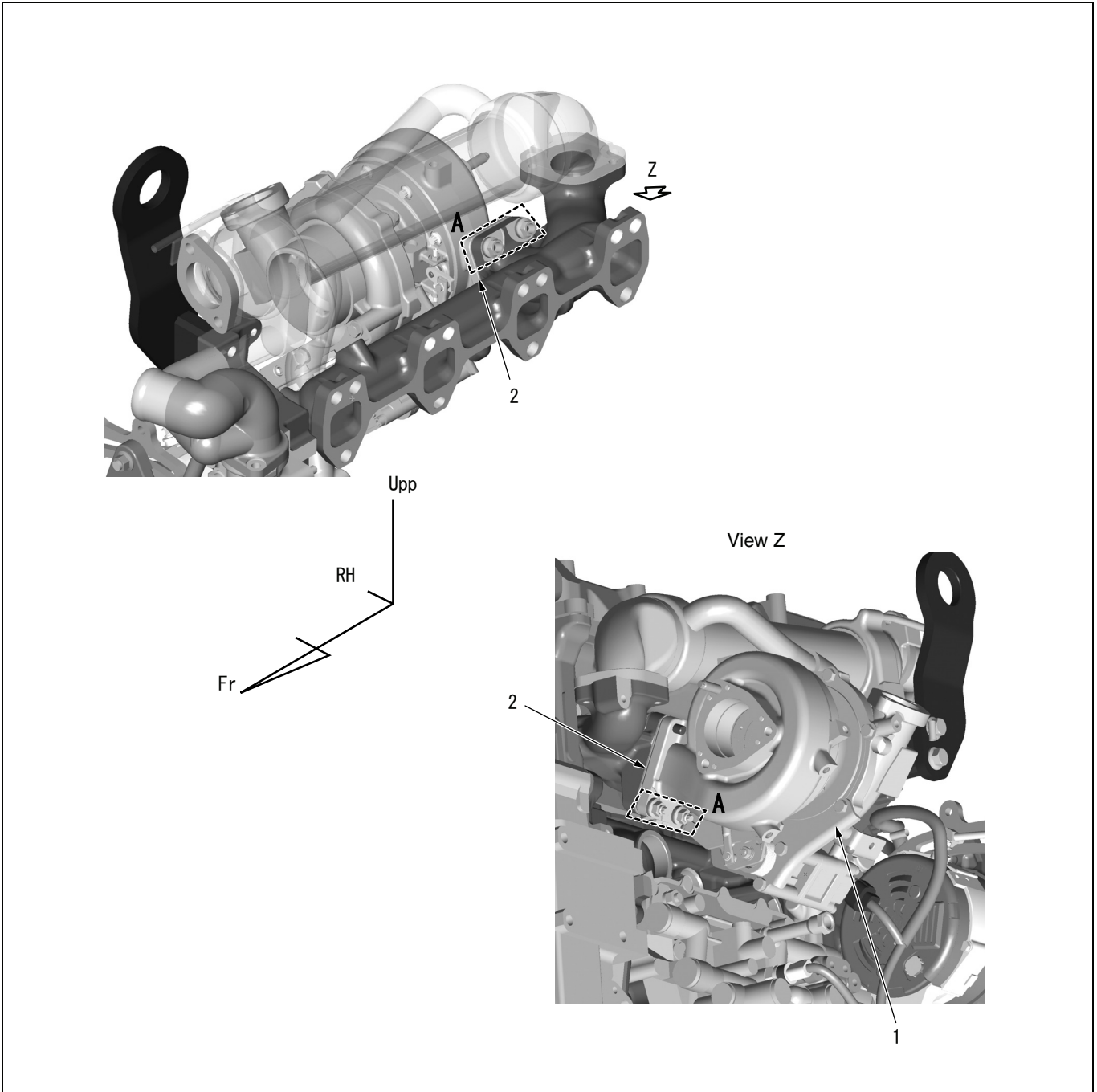

SAPH30ZAE1400004

1 Turbocharger assembly	2 Gasket*
-------------------------	-----------

*Parts not to be reused.

Tightening torque

A 70N· m{713kgf· cm}	
----------------------	--

Turbocharger

JP30002150601004

Status	Cause	Action
Oil is quickly reduced	Seal ring is excessively worn or damaged due to excessive wear of the bearing	Disassemble and repair turbocharger
	Engine oil enters into exhaust gas before the turbocharger	Check and service engine parts
	Clogged or damaged of oil return pipe, then engine oil is entering to blower side or turbine side	Repair or replace oil pipes
	Blower Impeller back side vacuum is excessive increase, then engine oil is entering to blower side	Check or replace oil pipes, replace or cleaning air cleaner element
Low engine output	Gas leak from exhaust system parts	Check and repair faulty areas
	Clogging of air inlet	Repair air inlet
	Gas leak from exhaust system parts	Check and repair faulty areas
	Clogging or damaging of exhaust system, then revolution of the turbocharger doesn't increase	Repair exhaust system
	Air leak from the blower side	Repair blower side
	Contamination of or damage to turbocharger	Replace turbocharger
	Operation defect of VG assembly	Check using Hino DX
	Seizure of bearing (lack lubrication or clogging of oil pipe)	Check lubrication system and repair, replace engine oil and turbocharger
	Seizure of bearing (Too hot oil temperature)	Check lubrication system and repair, replace engine oil and turbocharger
	Seizure of bearing (Turbine is eccentricity)	Check lubrication system and repair, replace engine oil and turbocharger
Seizure of bearing (Rapid stop from high load condition)	Drive correctly, according to the attention of the driver's manual, replace turbocharger	

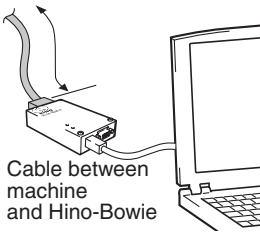
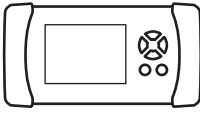
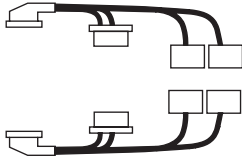
Part name	Part No.	External shape	General description and function
Cable between machine and Hino-Bowie	S0904-21220 (09042-1220)	 Cable between machine and Hino-Bowie	Cable for machine side diagnosis connector.
DENSO DST-i set			• Computer interface
without LCD without Bluetooth®	95171-01020		
without LCD with Bluetooth®	95171-01040		
with LCD without Bluetooth®	95171-01030		
with LCD with Bluetooth®	95171-01050		
Signal check harness	09843-E4050		Interrupting installation between unit side harness and ECU allows inspection with a tester rod while the power is supplied.

*1: To use Hino-Bowie (interface box) 09993-E9070, update the hardware. For details, refer to the user's manual in the HinoDX CD-ROM.

Keep updating the firmware (software built in the Hino-Bowie) using the software in the HinoDX CD-ROM. For details, refer to the user's manual in the HinoDX CD-ROM.

*2: HinoDX (Ver. 3.0.5 or later), only when use DST-i.

TERMINAL No.	TERMINAL SIGNAL	SIGNAL	TERMINAL No.	TERMINAL SIGNAL	SIGNAL
V41	–	–	V61	–	–
V42	–	–	V62	–	–
V43	–	–	V63	–	–
V44	–	–	V64	–	–
V45	ADG7	Sensor ground 7 (Accelerator sensor 1, P.T.O. accelerator sensor)	V65	ADG8	Sensor ground 8 (Accelerator sensor 2)
V46	ADG9	Sensor ground 9 (Exhaust gas temperature sensor, DPR differential pressure sensor)	V66	ADGU	Sensor ground 13 (Exhaust temperature sensor)
V47	ACS1	Accelerator sensor signal 1	V67	ACS2	Accelerator sensor signal 2
V48	–	–	V68	ASCS	P.T.O. accelerator sensor signal
V49	–	–	V69	ET3+	Exhaust gas temperature sensor (DPR inlet)
V50	–	–	V70	EXPS	DPR differential pressure sensor
V51	–	–	V71	AVC5	Sensor power supply 5 (P.T.O. accelerator sensor, DPR differential pressure sensor)
V52	–	–	V72	–	–
V53	–	–	V73	–	–
V54	–	–	V74	–	–
V55	CLSW	Clutch switch	V75	–	–
V56	DPSW	DPR refresh switch	V76	–	–
V57	ET4+	Exhaust gas temperature sensor (DPR outlet)	V77	–	–
V58	VB3	Power supply 3 (+B)	V78	VB4	Power supply 4 (+B)
V59	PGD2	Power ground 2	V79	PGD3	Power ground 3
V60	CGD2	Signal ground	V80	PGD4	Power ground 4

DTC code P0087 [76]**/Fuel system pressure control - low****DTC code P0088 [76]****/Fuel system pressure control - high****DTC code P2635 [76]****/Fuel pump "A" low flow / performance**

JP31ZEE170601006

1 CHECK THE FUEL

1. Check that suitable fuel at region temperature is used.

NO

Replace to suitable fuel

YES

2 CHECK THE FUEL FILTER AND FUEL PIPE FOR FUEL LEAKAGE

1. Check the fuel filter and fuel pipe for fuel oozing and leakage.

NO

- Defective fuel filter
- Defective fuel pipe

YES

3 CHECK THE FUEL TANK FOR CLOGGING OF THE AIR HOLE AND THE REMAINING AMOUNT

1. Check the air hole for clogging.
2. Check if fuel is sufficiently supplied.

NO

- Clogging of the air hole
- Insufficient fuel supply

YES

4 CHECK THE SUPPLY PUMP FOR FUEL LEAKAGE

1. Check the supply pump for fuel oozing and leakage.

NO

Faulty supply pump

YES

DTC code P0104 [17]**/Air flow sensor - out of range**

JP31ZEE170601008

1 CHECK INSTALLATION OF THE CONNECTOR

1. Check that the air flow sensor connector is properly installed.

NO

Faulty connector

YES

2 CHECK A DTC CODE

1. Make sure that air flow sensor power supply failure code (P06D3 [5], P06D4 [5]) is not output.

NO

Proceed to air flow sensor power supply failure diagnosis method (P06D3 [5], P06D4 [5])

YES

3 MEASURING FREQUENCY BETWEEN TERMINALS

1. Set the starter switch "LOCK" position.
2. Connect the signal check harness on the engine side.
3. Measure frequency between the terminals AFSI (E74) and AGD6 (E78) while idling.

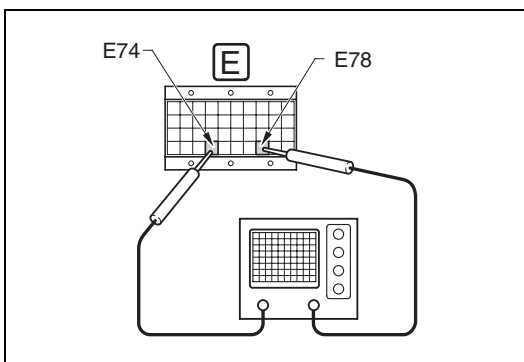

SAPH31ZAE1700032

Standard value

Idling revolution (r/min)	Frequency (kHz)
800	5 - 6

NO

Fault in air flow sensor

YES

Fault in engine ECU

4

MEASURING VOLTAGE BETWEEN TERMINALS

1. Connect the connector on the engine ECU side.
2. Disconnect the connector on the engine sub harness side.
3. Set the starter switch to "ON" position.
4. Measure voltage between the terminals THW+ (E66) and AGD5 (E58).

Standard value: 4.5-5.5 V

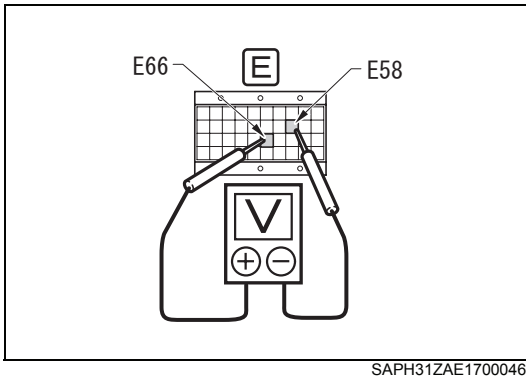

SAPH31ZAE1700046

NO

- Fault in engine ECU
- Faulty ECU connector

YES

Bad contact of connectors

2 MEASURING VOLTAGE BETWEEN SENSOR TERMINALS

1. Set the starter switch to "ON" position.
2. Measure voltage between the terminals FT2+ and FT2- of the fuel temperature sensor connector (engine sub harness side).

Standard value: 4.5-5.5 V

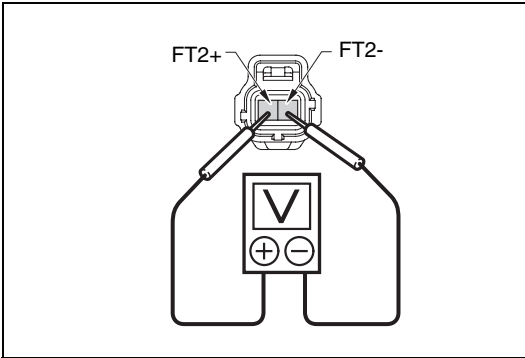

SAPH31ZAE1700062

NO

Proceed to 3

YES

Bad contact of connectors

3 MEASURING RESISTANCE BETWEEN TERMINALS

1. Set the starter switch to "LOCK" position.
2. Connect the signal check harness on the engine side.
3. Disconnect the connector on the engine ECU side.
4. Set the starter switch to "ON" position.
5. Measure resistance between the terminals THF+ (E48) and AGD2 (E76).

Standard value

Temperature (° C {° F})	Resistance (kΩ)
-20 {-4}	13.84 - 16.33
20 {68}	2.32 - 2.59
80 {176}	0.310 - 0.326
110 {230}	0.1399 - 0.1435

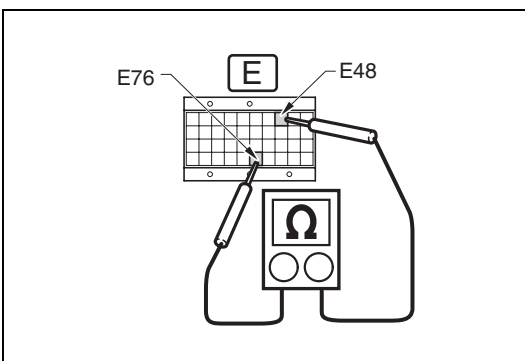

SAPH31ZAE1700063

NO

- Fault in fuel temperature sensor
- Fault in harness

YES

4

MEASURING RESISTANCE BETWEEN TERMINALS

1. Disconnect the connector on the engine sub harness side.
2. Connect the signal check harness on the engine side.
3. Measure resistance between the terminals AVC2 (E33), PCR3 (E64) and PCR4 (E65).

Standard value: 200-250 k Ω

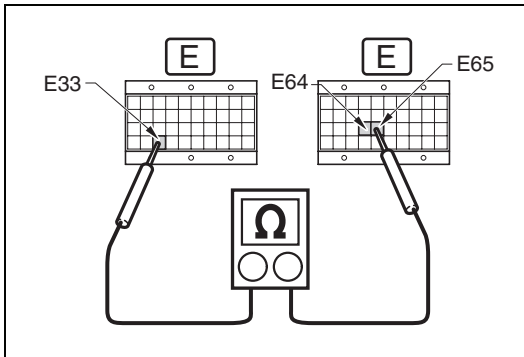

SAPH31ZAE1700081

YES

NO

Fault in engine ECU

DTC code P0237 [25]**/Boost pressure sensor - out of range (Out of range low)**

JP31ZEE170601022

1 MEASURING RESISTANCE BETWEEN SENSOR TERMINALS

1. Set the starter switch to "LOCK" position.
2. Disconnect the connector boost pressure sensor.
3. Check continuity between the terminals VCC and SIG of the boost pressure sensor connector.

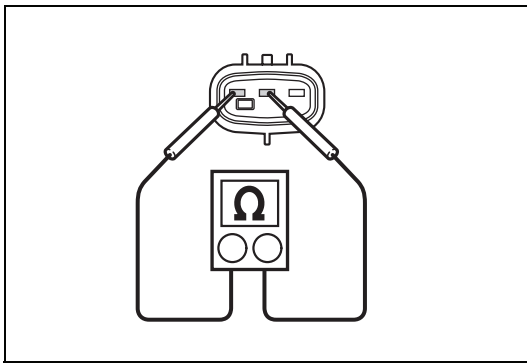

NOTICE • If it is difficult to check only the sensor, proceed to Step 4.

Standard value: 2-15 kΩ

4. Check continuity between the terminals SIG and GND of the boost pressure sensor connector.

Standard value: 2-15 kΩ

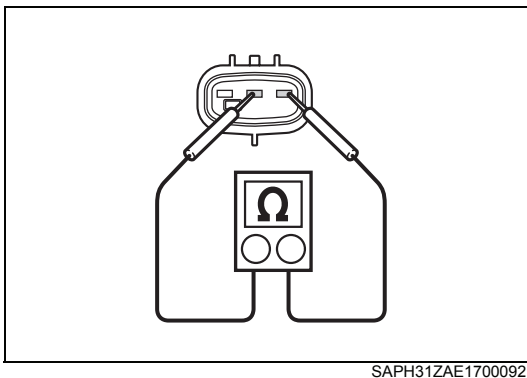

NO

Fault in boost pressure sensor

YES

DTC code P0340 [12]**/Camshaft position sensor - disconnection**

JP31ZEE170601026

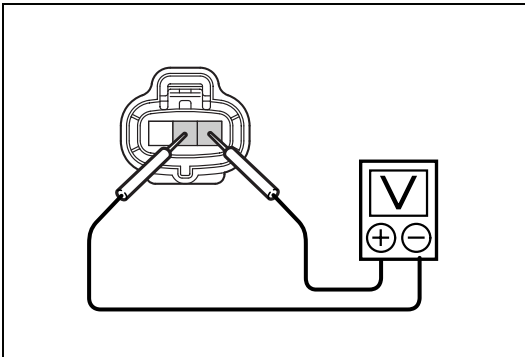
1 MEASURING VOLTAGE BETWEEN TERMINALS

SAPH31ZAE1700109

1. Set the starter switch to "LOCK" position.
2. Disconnect the connector on the engine sub speed sensor.
3. Set the starter switch to "ON" position and measure voltage between the terminals No.3 and No.2 of the engine sub speed sensor terminals (chassis harness side).

Standard value: 5.0±0.5 V

NO

[2] Go to measurement of voltage between terminals

YES

[3] Go to measurement of voltage between terminals

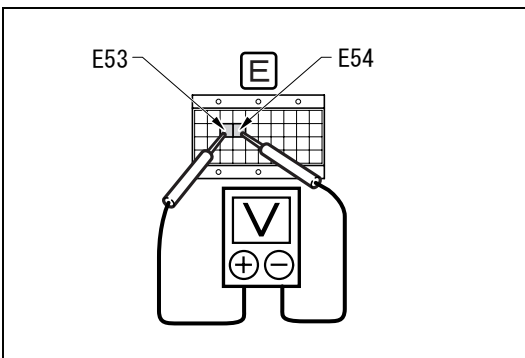
2 MEASURING VOLTAGE BETWEEN TERMINALS

SAPH31ZAE1700110

1. Connect the signal check harness to the engine ECU.
2. Measure voltage between the terminals E53 and E54 of the signal check harness.

ECU side terminal No.	Signal
E53	G+
E54	G-

Standard value: 5.0±0.5 V

NO

Engine ECU failure, connector failure

YES

Wiring harness failure

3

MEASURING RESISTANCE BETWEEN TERMINALS

1. Set the starter switch to "LOCK" position.
2. Connect the signal check harness on the unit side.
3. Disconnect the connector on the engine ECU side.
4. Measure resistance between the terminals ET3+ (V69) and ADG9 (V46).

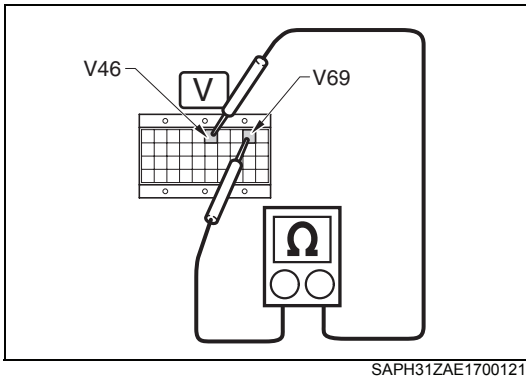

Standard value

Resistance	Temperature (° C {° F})
9.75 kΩ	50 {122}
3.77 kΩ	100 {212}
1.80 kΩ	150 {302}

NO

- Faulty exhaust gas temperature sensor (DPR inlet)
- Faulty harness
- Faulty sensor connector

YES

Fault in engine ECU

DTC code P06D3 [5]**/Air flow sensor power supply failure Short to GND**

JP31ZEE170601038

1 CHECK A MALFUNCTION CODE

1. Set the starter switch to "LOCK" position.
2. Disconnect the air flow sensor connector.
3. Set the starter switch to "ON" position.
4. Check that P06D3 [5] is no longer present.

NO

Proceed to 2

YES

Faulty air flow sensor

2 CHECK THE CONTINUITY IN HARNESS

1. Set the starter switch to "LOCK" position.
2. Connect the signal check harness.
3. Measure the resistance between the terminals AFVB (E12) and PGD4 (V80).

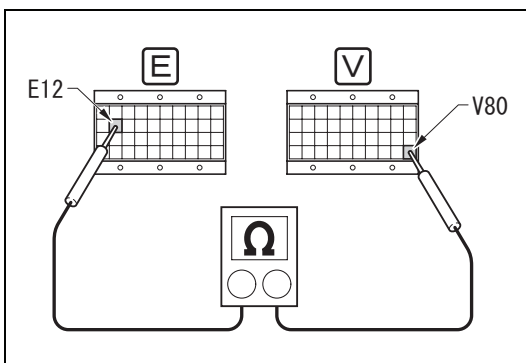
Standard value: $\infty\Omega$ 

SAPH31ZAE1700132

NO

Proceed to 3

YES

Faulty harness

5 MEASURING RESISTANCE BETWEEN TERMINALS

1. Connect the signal check harness on the engine ECU side.
2. Measure resistance between the terminals AVC1 (E13), PCR1 (E49) and PCR2 (E68).

Standard value: 200-250 k Ω

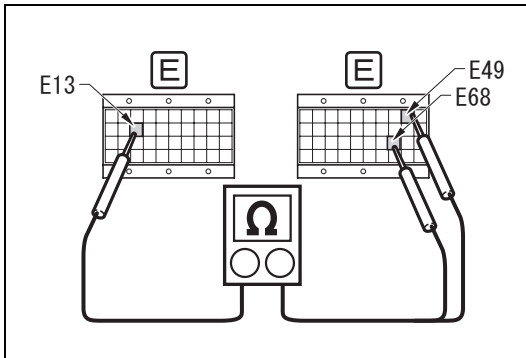

SAPH31ZAE1700148

NO

Fault in engine ECU (ECU connector)

YES

6 MEASURING VOLTAGE BETWEEN TERMINALS

1. Set the starter switch to "ON" position.
2. Measure voltage between the terminals AVC1 (E13) and AGD1 (E56).

Standard value: 4.5-5.5 V

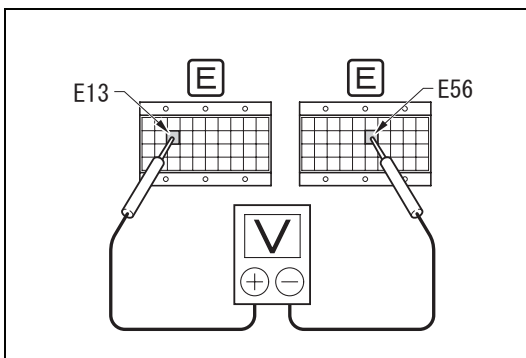

SAPH31ZAE1700149

NO

Fault in engine ECU (ECU connector)

YES

Replace the engine ECU

DTC code P1212 [68]

/Fuel injector driver circuit 1 - circuit (Circuit high)

JP31ZEE170601045

1 MEASURING VOLTAGE BETWEEN TERMINALS

1. Set the starter switch to "LOCK" and connect the signal check harness.
2. Turn "ON" the starter switch.
3. Measure the voltage between the terminals of ECU connector and ECU case GND.

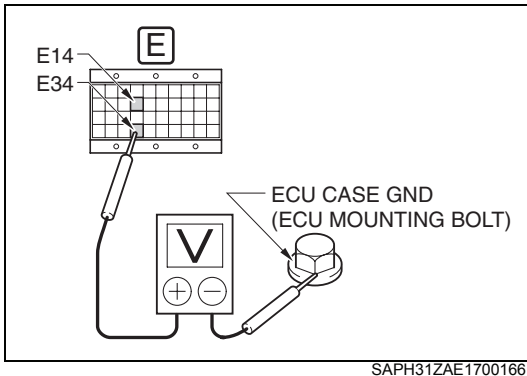

SAPH31ZAE1700166

CAUTION • Make sure that failure code which is concerned with engine ECU is not output.

+ side	- side
IJ1+ (E14)	ECU case GND
I1+S (E34)	

Standard value: 14 V or less

NO → Proceed to (3)

YES

2 CHECK OF FAILURE CODE

1. Turn the starter switch to "LOCK" position. Reconnect all the connectors.
2. Start the engine and erase the DTC.

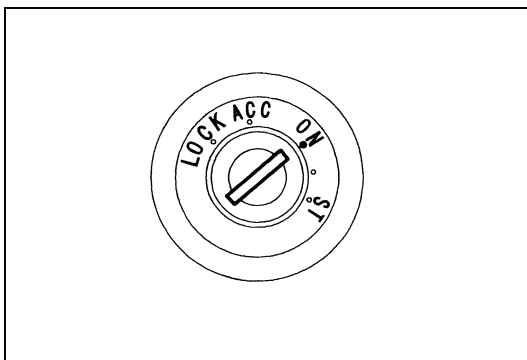

SAPH31ZAE1700164

3. If the same DTC is displayed, replace ECU. If no DTC is displayed, a temporary failure would have occurred.

NOTICE • It is necessary to re-write the engine ECU data if the engine ECU are replaced. Refer to the HinoDx operation manual.

DTC code P1428 [28]**/Differential pressure sensor - out of range (Out of range high)**

JP31ZEE170601049

1 MEASURING RESISTANCE BETWEEN SENSOR TERMINALS

1. Set the starter switch to "LOCK" position.
2. Disconnect the differential pressure sensor connector.
3. Check continuity between the terminals VCC and GND of the differential pressure sensor connector.

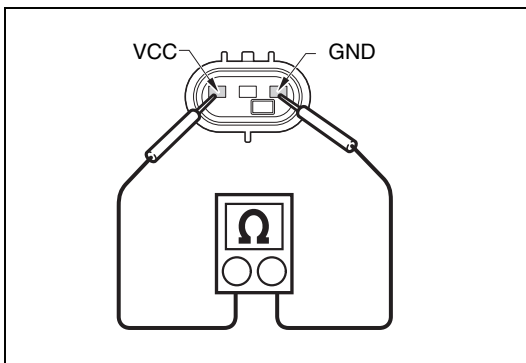
Standard value: 2-15 k Ω 

4. Check continuity between the terminals VOUT and GND of the differential pressure sensor connector.

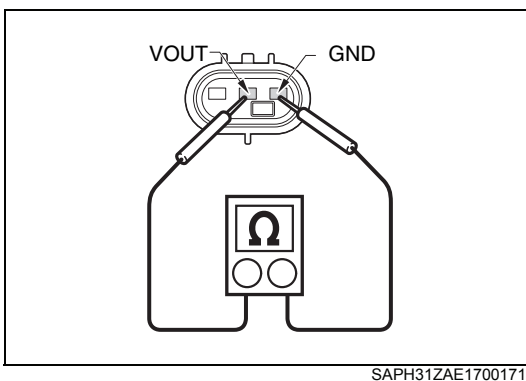
Standard value: 2-15 k Ω 

YES

NO

Faulty differential pressure sensor

DTC code P200C [91] /DPF over temperature

JP31ZEE170601053

1 INSPECTION OF SOOT LEAK

1. Remove the DPR, and check the rear roller end face.

Standard: No soot

NO

Replace the DPR

YES

2 INSPECTION OF THE DPR

1. Check that the exhaust gas is not large amount black smoke with DPR detached.

NO

Check the engine body

YES

3 INSPECTION OF THE EXHAUST GAS TEMPERATURE SENSOR (DPR OUTRET)

1. Check the resistance the exhaust gas temperature sensor.

NO

Replace the exhaust gas temperature sensor

YES

4 BASIC INSPECTION OF THE ENGINE

1. Clean the DPR by compressed air or replace the DPR, and do the basic inspection of the engine (Injector quantity check).

⚠ CAUTION • Perform it after the engine warm-up.

Standard value

Engine revolution (r/min)	Quantity (g)
1,000	10 - 30

NO

Check the injectors

YES

DTC code P2033 [27]**/Exhaust gas temperature sensor (DPR outlet) - out of range
(Out of range high)**

JP31ZEE170601055

1 MEASURING RESISTANCE BETWEEN SENSOR TERMINALS

1. Set the starter to the "LOCK" position.
2. Disconnect the exhaust gas temperature sensor (DPR outlet) connector.
3. Measure resistance between the terminals TEX3 and GND3 of the exhaust gas temperature sensor (DPR outlet).

NOTICE

- If it is difficult to check only the sensor, proceed to Step 3.

Standard value

Resistance	Temperature (° C {° F})
9.75 kΩ	50 {122}
3.77 kΩ	100 {212}
1.80 kΩ	150 {302}

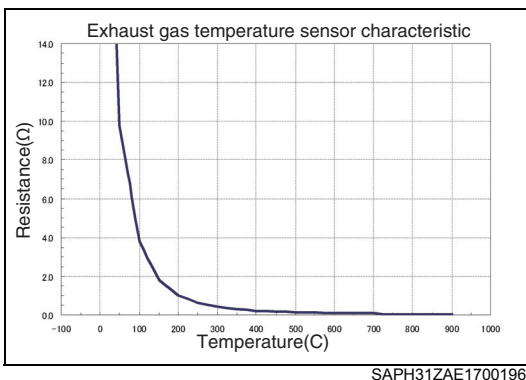
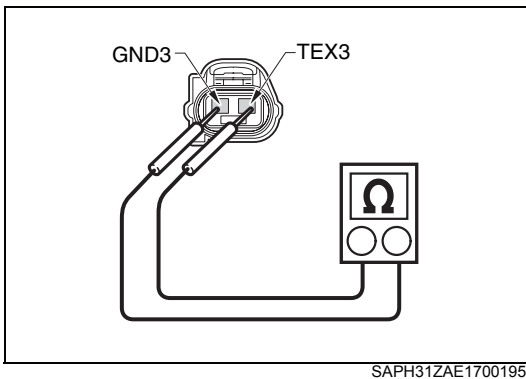

YES

NO

Faulty exhaust gas temperature sensor (DPR outlet)

DTC code P2122 [22]

/Accelerator pedal position sensor 1 - out of range (Out of range LOW)

DTC code P2123 [22]

/Accelerator pedal position sensor 1 - out of range (Out of range high)

JP31ZEE170601058

1 MEASUREMENT OF VOLTAGE BETWEEN TERMINALS

1. Turn the starter switch to "LOCK" position and connect the signal check harness.
2. Turn the starter switch to "ON" position and measure the voltage between V47 and V45 terminals of the signal check harness.

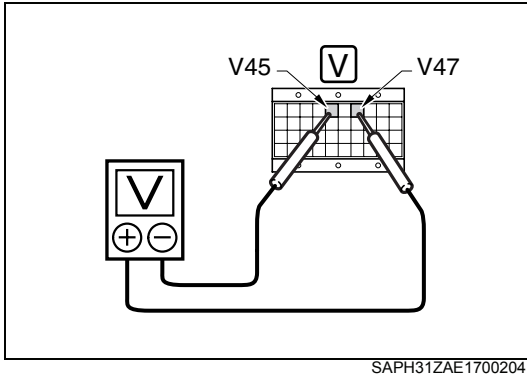

Standard value

Idling revolution (r/min)	Voltage (V)
800	0.3 - 1.5

NO → Measure the voltage mechatronic controller outlet port

YES

2 MEASUREMENT OF VOLTAGE BETWEEN TERMINALS

1. While increasing the throttle, measure the voltage between terminal V47 and terminal V45 of the signal check harness.

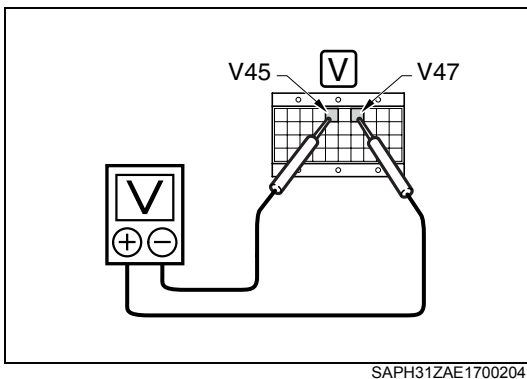

Standard value

Measuring item	Engine revolution (r/min)	Voltage (V)
Low idle	1,000	Approx. 1.4
High idle	2,100	Approx. 3.5

NO → Defective mechatronic controller

YES

Wiring harness failure

7. The "Caution window" will appear.

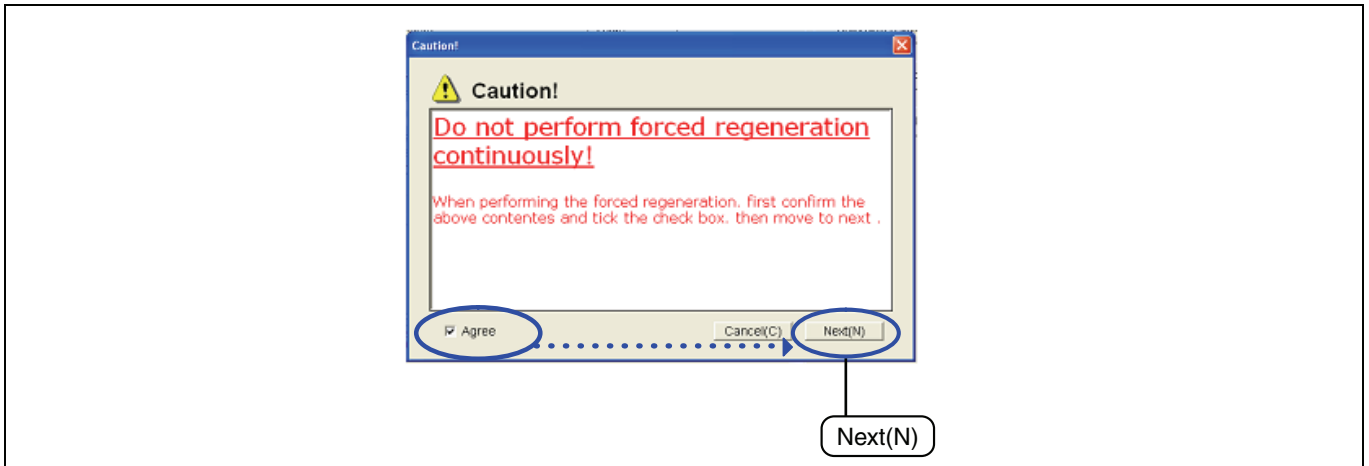

SAPH31ZAE1700190

- (1) Read the caution and accept its by clicking in the "Agree" check box on the left.
- (2) If you click "Next" button, the "Manual regeneration" window will appear.

⚠ CAUTION • The "Next" button is not displayed unless you check "Agree".

8. The "Manual regeneration" window will appear.

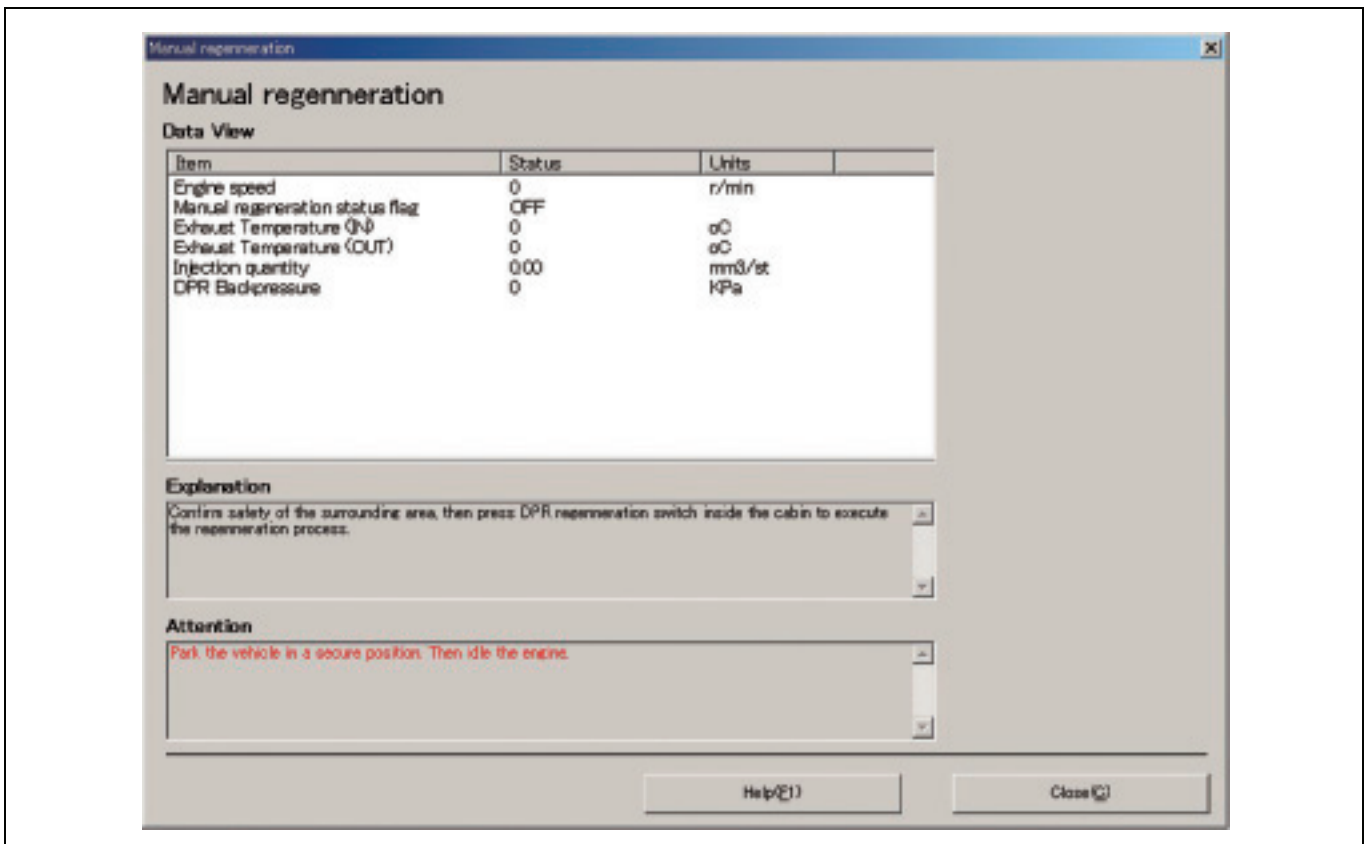

SAPH31ZAE1700191

4 DPR FORCED REGENERATION

1. Perform the DPR forced regeneration.

Standard: Regeneration was finished.

- ⚠ CAUTION**
- Never park the unit near any flammable material, including high grass or leaves, during manual regeneration.
 - Extreme heat from the exhaust outlet could cause a fire resulting in personal injury and property damage.
 - Always keep all flammable materials away from the DPR cleaner, exhaust pipe and tail pipes.
 - Never touch the DPR cleaner, exhaust pipe or tail pipe during regeneration. Severe burns and/or other personal injuries could occur.

- NOTICE**
- Manual regeneration time of the DPR is within 15 to 20 minutes approximately.

2. Turn on the starter switch

Start HinoDX and select [Lamp control select status for DPR] under the customization items. Change the initial value from 0(Inactive) to 1(Active), then click on the "Change" button (upper left).

- ⚠ CAUTION**
- After setting the value to 1, the function will be active from the reboot.

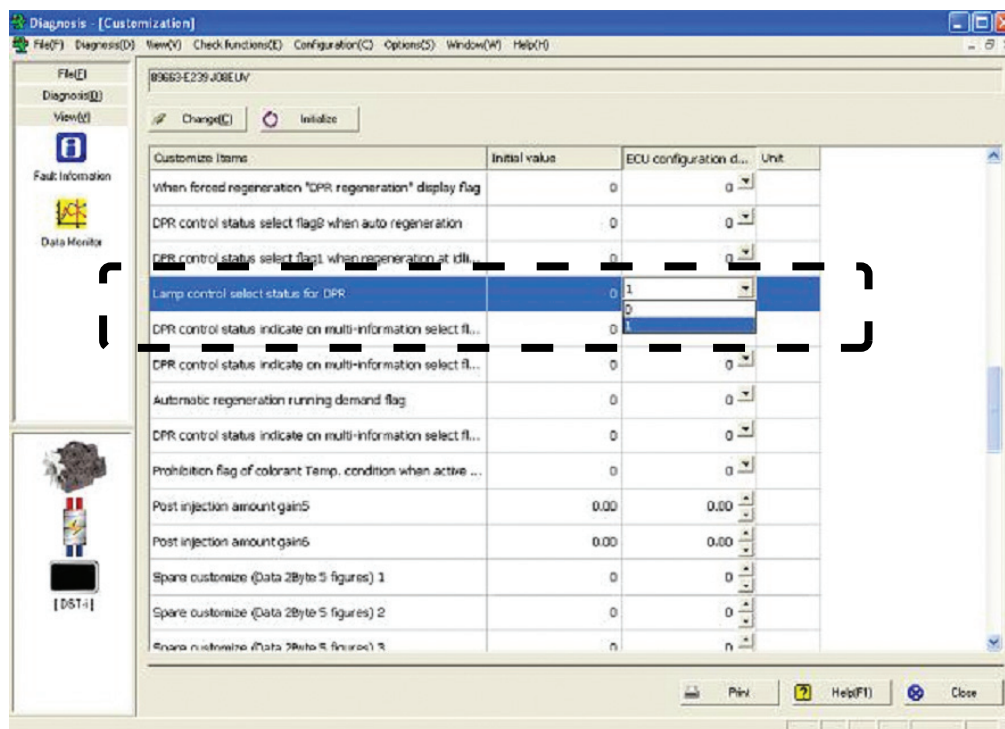

CLICK HERE TO **DOWNLOAD** THE COMPLETE MANUAL

- Thank you very much for reading the preview of the manual.
- You can download the complete manual from: www.heydownloads.com by clicking the link below



- Please note: If there is no response to CLICKING the link, please download this PDF first and then click on it.

CLICK HERE TO **DOWNLOAD** THE COMPLETE MANUAL