

TNV series

**ELECTRONIC CONTROL
MANUAL**

YANMAR

FOR EPA TIER3

3TNV84T-Z

4TNV84T-Z

4TNV98T-Z

4TNV98-Z(R80-7A)

4TNV98-E(R55-7A,R55W-7A)

OPTION

3TNV82A-Z

3TNV88-Z, 3TNV88-E

3TNV88-Z, 4TNV88-E

REFERENCE ONLY

- MINI-EXCAVATOR(5~8TON, -7A SERIES)

YANMAR

CLICK HERE TO **DOWNLOAD** THE COMPLETE MANUAL

- Thank you very much for reading the preview of the manual.
- You can download the complete manual from: www.heydownloads.com by clicking the link below



- Please note: If there is no response to CLICKING the link, please download this PDF first and then click on it.

CLICK HERE TO **DOWNLOAD** THE COMPLETE MANUAL

SPECIFICATIONS

4TNV88-B

4TNV88-Z (Option Electronic Control System)

Engine model			4TNV88-B/4TNV88-Z													
Engine classification			CL		VM											
1	Type	—	Vertical, 4-cycle water-cooled diesel engine													
2	Combustion system	—	Direct injection (DI)													
3	No. of cylinders - Bore × Stroke	n - mm × mm	4 - 88×90													
4	Displacement	ℓ	2.189													
5	Rated engine speed	min ⁻¹	1500	1800	2000	2100	2200	2300	2400	2500	2600	2700	2800		3000	
	Output (Gross) *1	Cont. rating	kW	16.9	20.5											
		Rated output	kW	18.5	22.5	24.6	25.9	27.1	28.4	29.7	31.0	32.3	33.6	35.0		36.9
	Output (NET)	Cont. rating	kW	16.4	19.6											
Rated output		kW	18.0	21.6	24.1	25.3	26.5	27.7	28.8	30.1	31.3	32.5	33.7		35.4	
6	Maximum idling speed	min ⁻¹ ±25	1600	1895	2180	2290	2400	2510	2590	2700	2810	2920	2995		3210	
7	Specific fuel consumption	g/kWh	≤245							≤252						
8	Exhaust gas temp.	°C (°F)	≤520	≤540	≤560	≤570	≤580	≤590	≤600	≤610	≤620	≤630	≤640		≤660	
9	Compression ratio	—	19.1													
10	Diesel fuel injection pressure	MPa (kgf/cm ²)	19.6 ^{+1.0} ₀ (200 ⁺¹⁰ ₀)													
11	Main shaft side	—	Flywheel side													
12	Rotation direction	—	Counterclockwise (Viewed from flywheel side)													
13	Governor	—	Mechanical governor (All-speed governor) / Electronic governor (All-speed governor)													
14	Aspiration	—	Natural aspiration													
15	Cooling system	—	Liquid-Cooled With Radiator													
16	Lubricating system	—	Forced lubrication with multi-stage trochoid pump													
17	Starting system	—	Electric starting													
18	Charging system	—	Alternator (12 VDC/40 A)													
19	Starting aid device	—	Super-quick Heating Glow plug													
20	Engine oil pressure	Rated speed	MPa	0.34±0.05 (3.5±0.5)												
21	Oil pan capacity	Full	ℓ	7.4												
		Useful	ℓ	3.4												
22	Engine coolant capacity	ℓ	2.7 (Engine only)													
23	Cooling fan type - dia. × No. of blades	mm	Made by resin, Pusher, F Type - φ370(EF)×6													
24	Crank V-pulley dia./ Fan V-pulley dia.	mm/mm	φ120 / φ90				φ110 / φ110									

Note: This table is subject to change for performance improvement.

*1: Gross outputs are theoretical, calculated from cooling fan formula. These are for reference only.

This Page Intentionally Left Blank

CONTROL SYSTEM

Current consumption

The current consumption for engine control is shown in **Table 2-2**. A current of at least 4 or 5 A should always be stored in the battery for engine control. (We recommend a stored current of 5 A for frequent cold starts or 4A for otherwise).

Table 2-2 Current consumption for engine control

	Design value	Measured value	
		rms	Max.
E-ECU GND	5.40 [A]	3.72 [A]	6.56 [A]
CSD	1.90 [A]	0.90 [A]	1.02 [A]
Air heater relay excitation	0.20 [A]	-	-
Panel switch	0.10 [A]	-	-
Total	7.60 [A]	4.61 [A]	7.58 [A]

Note: Power supply voltage is assumed to be 14.8V.

CONTROL SYSTEM

Table 2-6 Electrical requirements of the commercially available electrical parts used for the Eco-governor

Part name	Electrical requirements
Air heater relay	Contact Normally open (a-contact) Rated voltage 12 Vdc Rated load current 400 W: 12 Vdc/40 A Min., 4 min. (@ 30°C) 500 W: 12 Vdc/50 A Min., 4 min. (@ 30°C) 800 W: 12 Vdc/80 A Min., 4 min. (@ 30°C) 1000 W: 12 Vdc/90 A Min., 4 min. (@ 30°C) Coil current 12 Vdc/1.0 A Max. Coil inductance 200 mH Max. Switching durability 10 ⁶ times or more Other features must be compliant with applicable specifications.
Failure lamp	Lamp load 12 V - 3.4 W Max.
Preheat lamp	Rush current 12V/3 A-10ms Max.
Harness	Must meet the requirements shown on the standard connection diagrams. (E3-29927-0030, E3-29927-0040)
Coolant temperature switch	Contact Normally open (a-contact)
Air cleaner (with sensor switch)	When connected to E-ECU: Max. current 20 mA or higher Min. current 10 mA or lower
Oily water separator (with sensor switch)	
Key Switch	When the switch is moved from the ON position to the START position, no instantaneous power interruption must occur.
Oil pressure sensor	Not to be connected to the E-ECU.
Coolant temperature sensor	Not to be connected to the E-ECU.

The fulfillment of the requirements shown in the table above does in no way constitute a warranty by Yanmar of user-selected commercially available parts.

CONTROL SYSTEM

Contact input

There are two schemes for contact input of the E-ECU: High-side input and Low-side input. See **Figure 2-17**. The contact input of the E-ECU has been designed with the same sink current and source current of 1.0 mA typ.

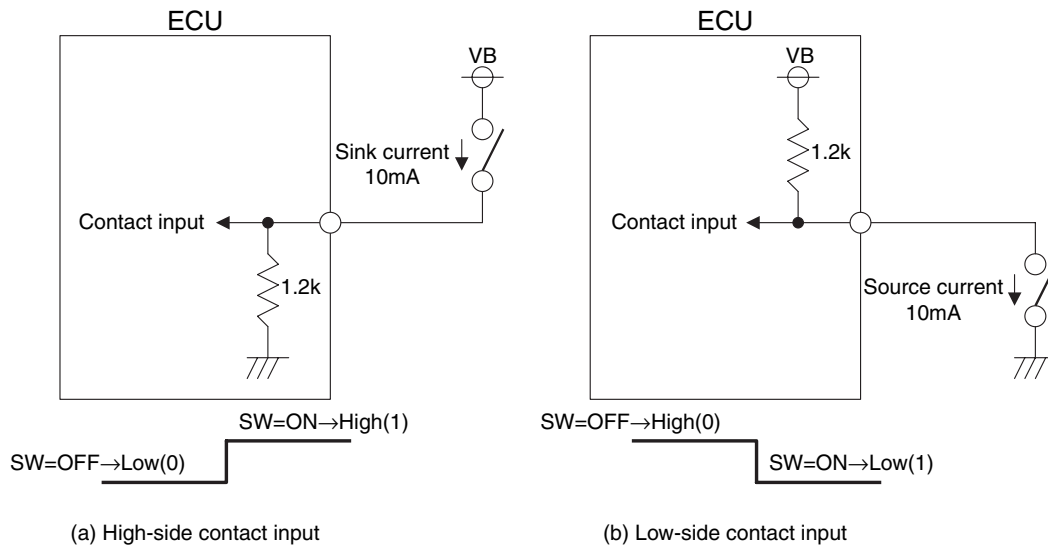

Figure 2-17 Contact input schemes and input logics

There are two types of switch contacts connected to contact inputs: Normally open (NO) contact and normally closed (NC) contact.

Figure 2-18 illustrates the voltage levels at the input terminal for the high-side contact input. When the switch turns on, the input terminal goes high for the switch with NO contact and goes low for the switch with NC contact.

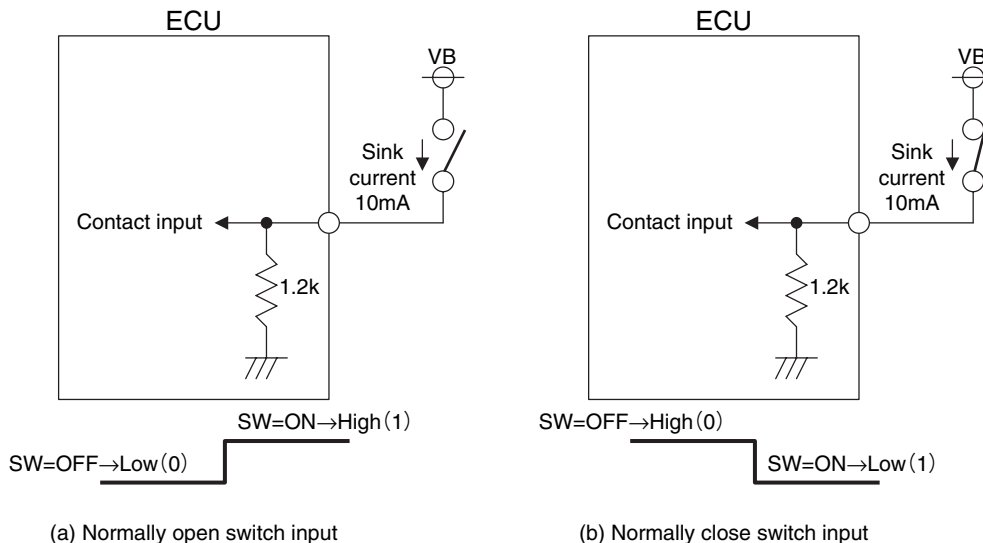

Figure 2-18 Switches for high-side contact input

CONTROL SYSTEM

Calculation of load factor

The load factor of the engine is determined as a percentage from the rack position at idling (R_{idl}), maximum rack position (R_{max}), minimum rack position (R_{min}) and actual rack position relative to R_{min} (R_{act}). See **Figure 2-32**.

The calculated load factor is delivered as a PWM signal from an E-ECU terminal or through CAN communication.

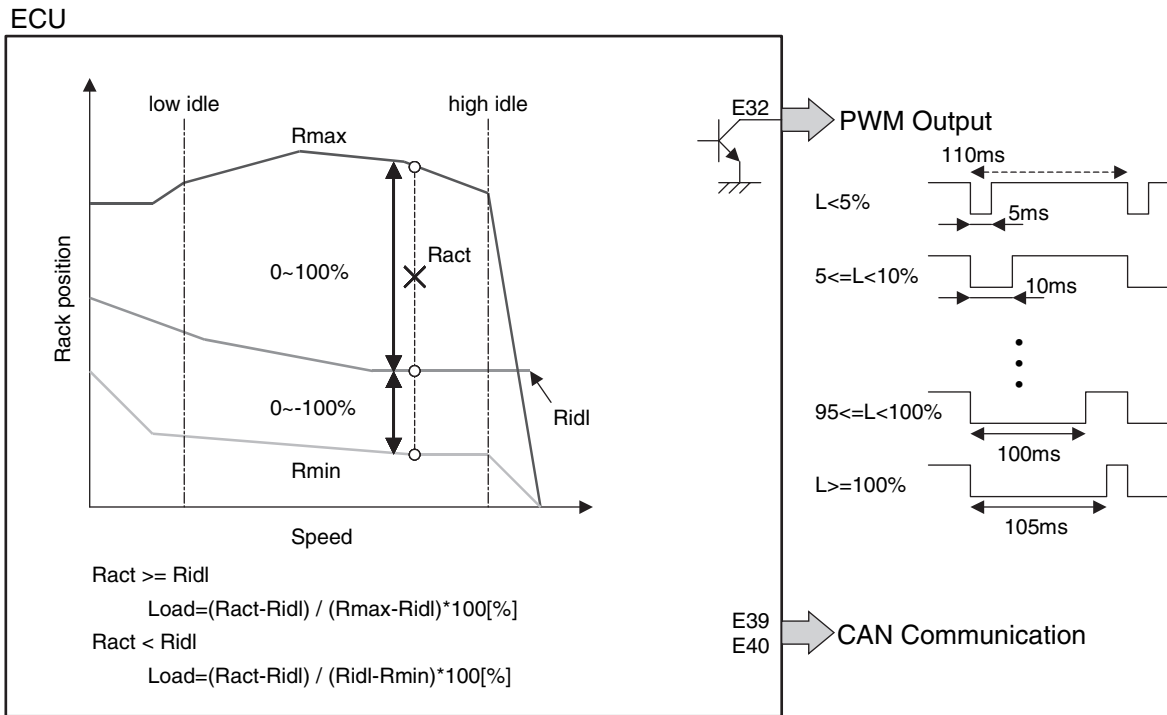

Figure 2-32 Calculation of load factor

CONTROL SYSTEM

(3) Auto deceleration mode

Figure 2-43 shows the connection diagram for auto deceleration mode.

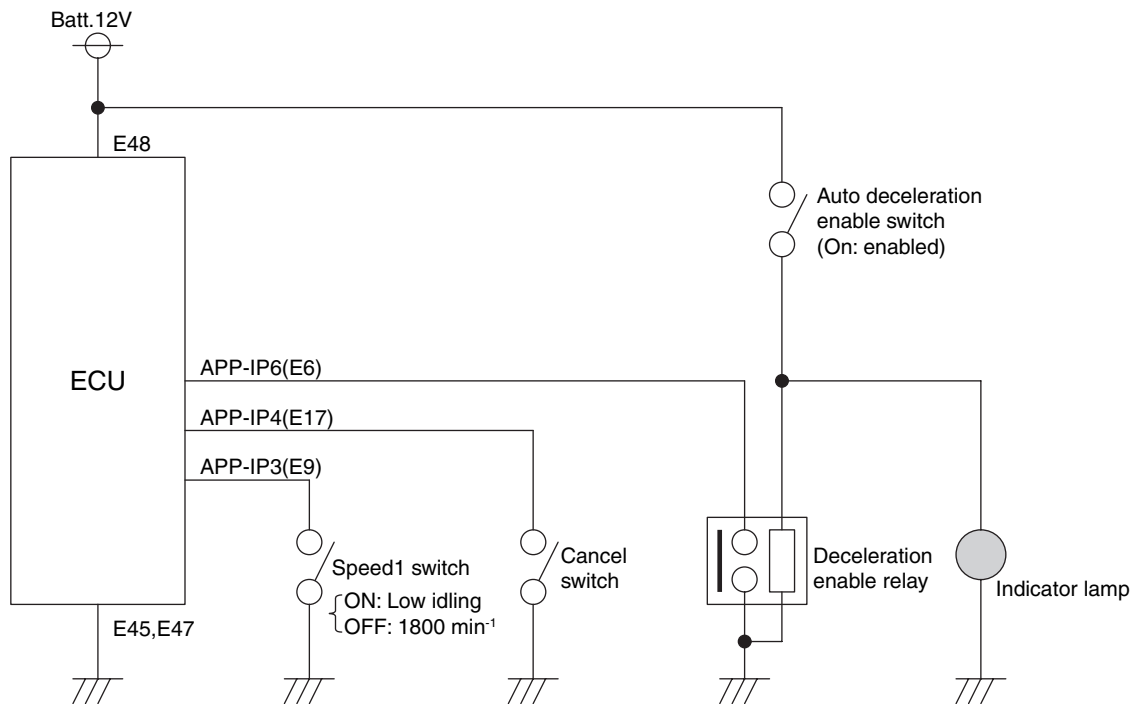

Figure 2-43 Connection diagram for auto deceleration mode

Figure 2-44 shows the operation timing for auto deceleration mode.

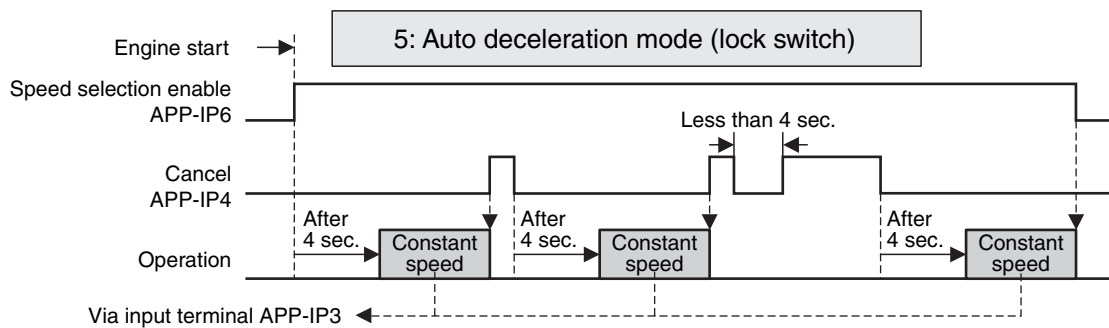

Figure 2-44 Operation timing for auto deceleration mode

Caution:

The type of the speed selection enable switch (toggle or momentary) is mapped. As a momentary switch involves the possibility of a sudden change in engine speed if the E-ECU is reset, it is recommended to use a toggle switch.

External switch input can be replaced with CAN communication input.

CLICK HERE TO **DOWNLOAD** THE COMPLETE MANUAL

- Thank you very much for reading the preview of the manual.
- You can download the complete manual from: www.heydownloads.com by clicking the link below



- Please note: If there is no response to CLICKING the link, please download this PDF first and then click on it.

CLICK HERE TO **DOWNLOAD** THE COMPLETE MANUAL

CONTROL SYSTEM

Terminal assignment

Each of the E-ECU terminals listed in **Table 2-14** is assigned multiple functions. The active function for each terminal can be changed by mapping.

By default, function 1 is enabled. Contact Yanmar for setting change.

Table 2-14 E-ECU terminals assigned multiple functions

Terminal No.	Terminal name	Function 1 (default)	Function 2	Function 3	Function 4
E24	APP-IP1	Droop selection	Starter enable	-	-
E14	APP-IP2	Rmax 2	Oil pressure switch	Speed up	Foot pedal NO switch
E9	APP-IP3	Speed 1	Charge alarm	-	-
E17	APP-IP4	Speed 2	Coolant temperature switch	-	-
E5	APP-IP5	Reverse droop	Air cleaner	Machine (up)	Pulse accelerator
E6	APP-IP6	Speed selection enable	Oily water separator	Machine (down)	-
E13	APP-IP7	Rmax 1	Stop 2 switch	-	Foot pedal NC switch
E20	APP-OP1	Starter relay	Middle-speed lamp	-	-
E2	APP-OP2	Eco-mode lamp	Block heater relay	Speed change indication lamp	Coolant temperature alarm lamp

Contact input terminal switches are available in two types: NC (normally closed) and NO (normally open).

Table 2-15 lists contact input terminals for which a NO or NC switch can be selected.

Table 2-15 Contact input terminal switches available in NC and CO types

Terminal No.	Terminal name	Default function	Default input logic
E24	APP-IP1	Droop selection	NC
E14	APP-IP2	Rmax 2	NO
E9	APP-IP3	Speed 1	NO
E17	APP-IP4	Speed 2	NO
E5	APP-IP5	Reverse droop	NO
E6	APP-IP6	Speed selection enable	NO
E13	APP-IP7	Rmax 1	NO
E15	SHUDNSW	Engine stop	NO

Part Number	129927-77920
Coil rated voltage	12 Vdc
Rated excitation current	117 mA
Contact type	a-contact
Contact rated voltage	12 Vdc
Contact rated current	83 A for 200 seconds

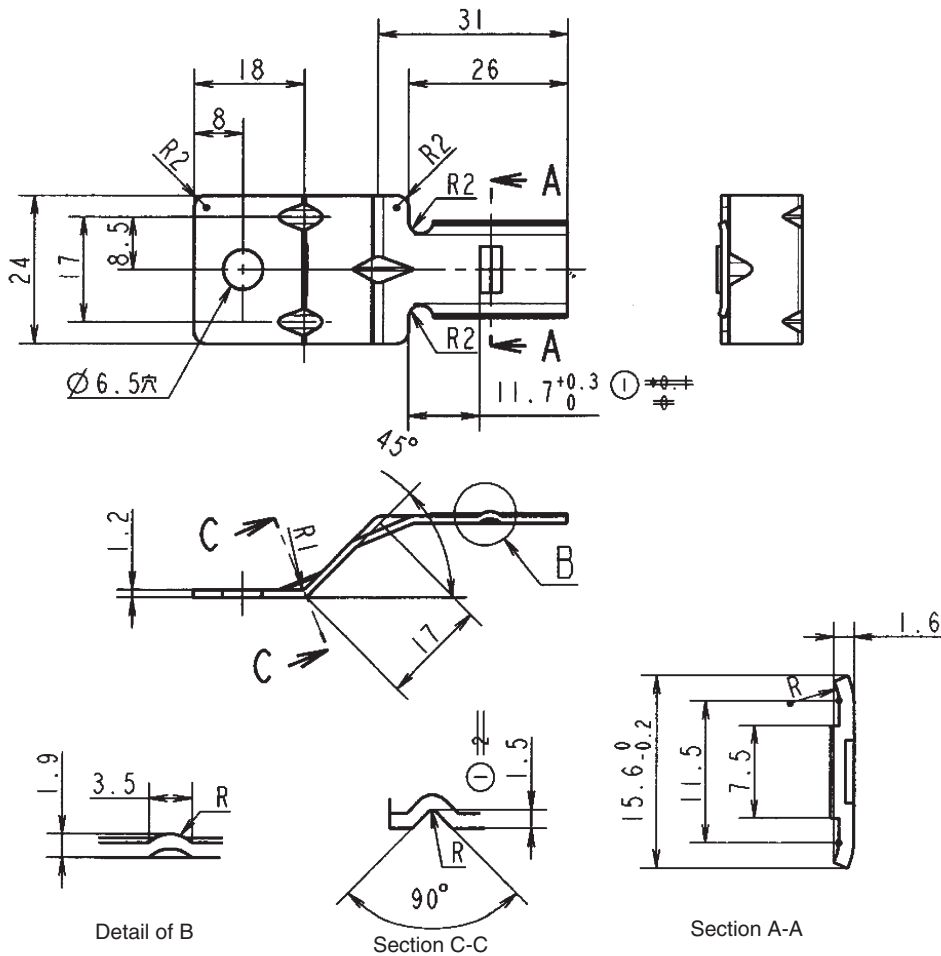

Figure 2-60 Bracket for ISO relay (129927-77910)

1. Overview

The YANMAR Engine Diagnostic Service Tool (YEDST) for the TNV series is software to support troubleshooting and installation/maintenance services for electronic control engines. It runs on personal computers (PC/AT) running Windows operating system.

2. System Requirements

The following are required to operate the YANMAR Engine Diagnostic Service Tool (YEDST).

PC……PC/AT compatible

- Communication port : USB
- Display resolution : 1024 × 768
- OS : Windows 2000 Professional SP1, Windows XP Professional, Windows XP Home, Windows XP Tablet PC Edition

Communication IF box

- Firmware version : 02.15
- DLL version : 02.00
- API version : 02.02

Cables

- USB cable
- Diagnostic cable

6. Screen Components

6.1 Basic screen

1) Tool bar

- ① Standard tool bar : The standard tool bar provides basic operations of ② to ④ . Shortcut keys, [Alt] key + [Parenthesized character], are available.
- ② Operation tool bar : This tool bar provides operations available on each screen. Unavailable operations are displayed dim.
- ③ Function select tool bar : This tool bar lets you select a basic function. It corresponds to View on the standard tool bar.
- ④ View select tool bar : This tool bar lets you select a screen in each function. It corresponds to the submenu of View on the standard tool bar.

2) View

- ⑤ Main view : Displays the details of the selected function.
- ⑥ Additional Information view : Display area specific to screens that show graphs and chronological data.
- ⑦ Comment view : This view usually displays the current trouble status. On the screen to display trouble codes, it displays trouble criteria and troubleshooting results.
- ⑧ Status view : Displays the current communication status.

3) Function buttons

Functions not supported by the standard tool bar (Clear button, etc) are displayed as buttons in the Main view and Additional Information view.

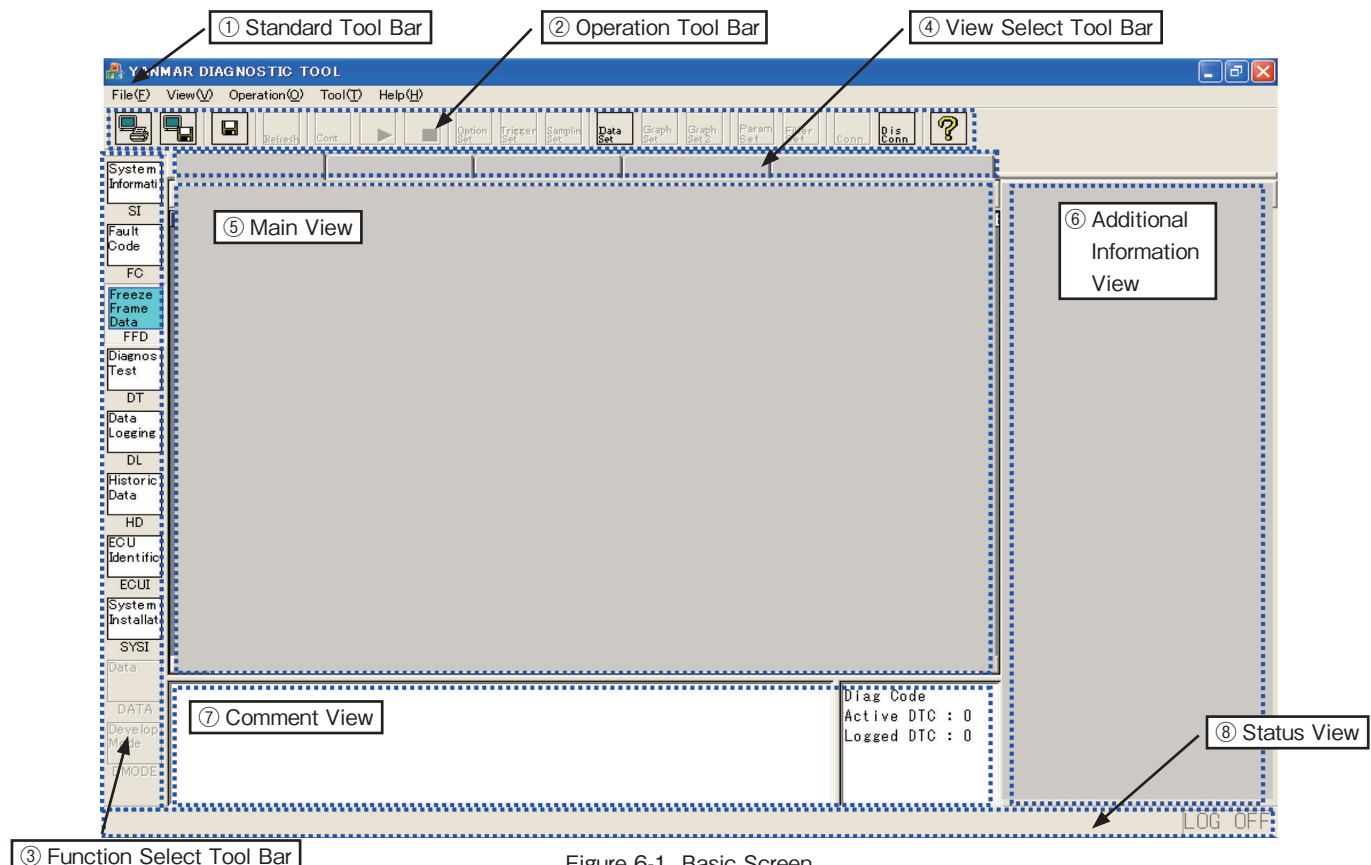

Figure 6-1 Basic Screen

7.3.2 Trend Graph

1) Additional Information view (Cursor Value)

The data item names selected in graph setting operation and the values at the cursor position are displayed.

<Graph 1> : Cursor values of Graph Top. <Graph 2> : Cursor values of Graph Bottom.

① "Position" : Displays the data number at the cursor point.

② "Displayed item and data" : Displays an item name and data. The background color corresponds to the graph line color.

2) Operation tool bar

③  : Prints a hardcopy of the screen.

④  : Saves buffered data in a CSV file.

⑤  : Lets you specify displayed items and scaling for the top graph.

⑥  : Lets you specify displayed items and scaling for the bottom graph.

3) Main view

Displays graph 1 and graph 2. For information on operations related to graphs, see Chapter 8.

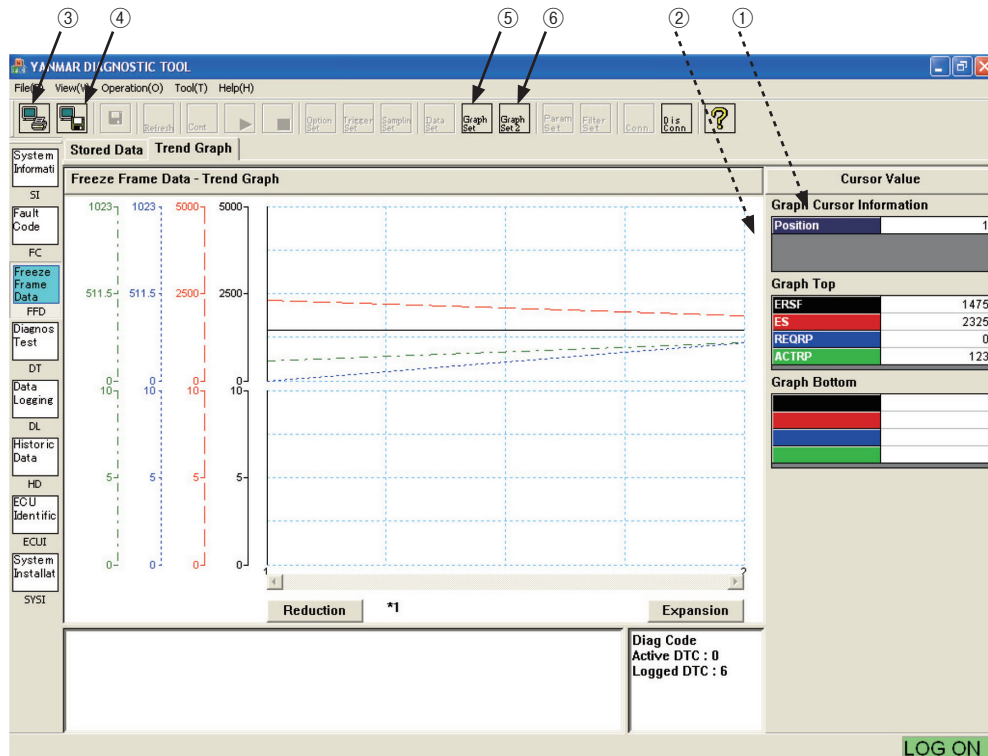

Figure 7-6 [FFD] - [Trend Graph] Screen









7.5 Data Logging 【Mechanic Function】

This tool lets you perform troubleshooting and analyze running status while operating the engine. You can select a submenu from : Data Monitor that displays logged data in real time, Stored Data that displays stored data, and Trend Graph that shows data in graphic format. Logging data consists of FFD and data at 8 points you can set freely. The trigger setting function is provided to facilitate saving data.

7.5.1 Data Monitor

This function receives and displays measured data and control information of ECU's sensor at preset sampling intervals (minimum : 0.1 second). You can set the trigger function to start storing data.

1) Operation tool bar

- ①  : Prints a hardcopy of the screen.
- ②  : Saves the screen in BMP format.
- ③  : Starts receiving data. (Data that has not been saved in "7.5.2 Stored Data" is overwritten and deleted.)
- ④  : Stops receiving data manually.
- ⑤  : Sets data to be received. Clicking this button opens the Data Set sub-window, which lets you make changes (up to 10 points).
- ⑥  : Lets you set option data. Clicking this button opens the Option Data Set sub-window, which lets you make changes.
- ⑦  : Sets the trigger conditions (trigger ON/OFF, data selection, level selection, and trigger type), the number of delay points, and the number of stored data points. Clicking this button opens the Trigger Setting sub-window, which lets you make changes.
- ⑧  : Sets the sampling frequency. Clicking this button opens the Sampling Setting sub-window, which lets you make changes.

2) Main view

- ⑨ **Description** : Displays a data name to be logged.
- ⑩ **Value** : Displays the measured value.
- ⑪ **Unit** : Unit.
- ⑫ **Notes** : Field for notes.



7.7 ECU Identification [Mechanic Function]

This function is used to display engine system/ECU's ID information, and ECU I/O channel assignment information. A level-2 password is required to display the data.

7.7.1 Analog Channels

This screen displays the analog signal information including the channel assignment, unit, scaling, etc.

1) Operation tool bar

- ①  : Prints a hardcopy of the screen.
- ②  : Saves the screen in BMP format.

2) Main view

- ③ **LID** : Data management number called local ID.
- ④ **CID (SPN)** : Parameter ID number complying with SAE J1939. Used as a common ID.
- ⑤ **Description** : Description of the sensor, signal, etc.
- ⑥ **Acronym** : Acronym (complying with the SAE standard)
- ⑦ **Size** : Data length.
- ⑧ **Resolution** : Resolution.
- ⑨ **Offset** : Offset.
- ⑩ **Unit** : Unit.
- ⑪ **Range** : Range.

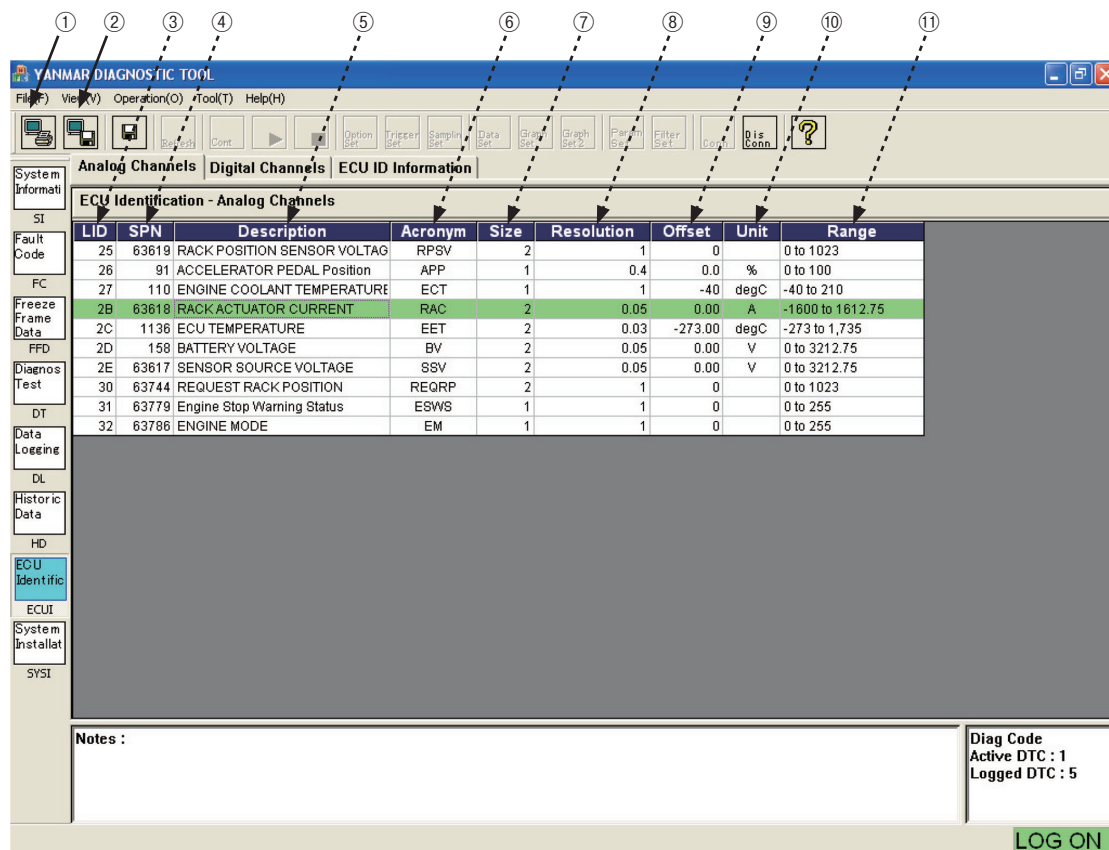

The screenshot shows the 'YANMAR DIAGNOSTIC TOOL' interface. The main window displays 'ECU Identification - Analog Channels' with a table of sensor data. The table has columns for LID, SPN, Description, Acronym, Size, Resolution, Offset, Unit, and Range. A 'Notes' section at the bottom right indicates 'Active DTC : 1' and 'Logged DTC : 5'. A 'LOG ON' button is visible at the bottom right of the interface.

LID	SPN	Description	Acronym	Size	Resolution	Offset	Unit	Range
25	63619	RACK POSITION SENSOR VOLTAGE	RPSV	2	1	0		0 to 1023
26	91	ACCELERATOR PEDAL Position	APP	1	1	0.4	%	0 to 100
27	110	ENGINE COOLANT TEMPERATURE	ECT	1	1	-40	degC	-40 to 210
2B	63618	RACK ACTUATOR CURRENT	RAC	2	0.05	0.00	A	-1600 to 1612.75
2C	1136	ECU TEMPERATURE	EET	2	0.03	-273.00	degC	-273 to 1,735
2D	158	BATTERY VOLTAGE	BV	2	0.05	0.00	V	0 to 3212.75
2E	63617	SENSOR SOURCE VOLTAGE	SSV	2	0.05	0.00	V	0 to 3212.75
30	63744	REQUEST RACK POSITION	REQRP	2	1	0		0 to 1023
31	63779	Engine Stop Warning Status	ESWS	1	1	0		0 to 255
32	63786	ENGINE MODE	EM	1	1	0		0 to 255

Notes :
 Active DTC : 1
 Logged DTC : 5



LOG ON

Figure 7-24 [ECU Identification] - [Analog Channels] Screen

7.8.2 Calibration [Mechanic Function]

This screen provides the function to calibration (correct) the sensor. You can perform the digital calibration of the reference position for the accelerator position sensor, and check the origin calibration value at the time of injection.

1) Operation tool bar

- ①  : Prints a hardcopy of the screen.
- ②  : Saves the screen in BMP format.
- ③  : Saves buffered data in a CSV file.

2) Main view

- ④ **Description** : Calibration item.
- ⑤ **Offset** : Displays the current offset value. Clicking this field opens the Data Set window that lets you change the value.
- ⑥ **Notes** : Notes.

• The Data Set window is the same as that for the Configuration screen. See the previous section.

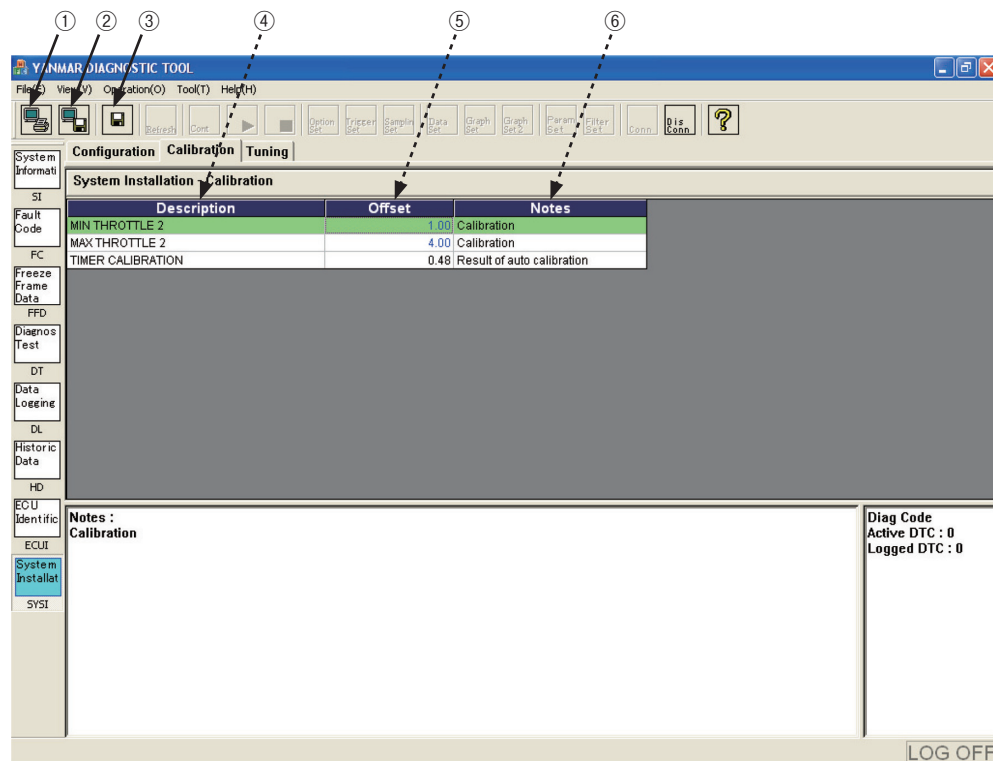

Figure 7-33 [System Installation] - [Calibration] Screen

CLICK HERE TO **DOWNLOAD** THE COMPLETE MANUAL

- Thank you very much for reading the preview of the manual.
- You can download the complete manual from: www.heydownloads.com by clicking the link below



- Please note: If there is no response to CLICKING the link, please download this PDF first and then click on it.

CLICK HERE TO **DOWNLOAD** THE COMPLETE MANUAL