

2020 Jeep Truck Compass 4WD L4-2.4L

Vehicle > Heating and Air Conditioning > Diagrams > Electrical (OE)

A/C CONTROL SYSTEM - 2.4L

A/C CONTROL SYSTEM - 2.4L

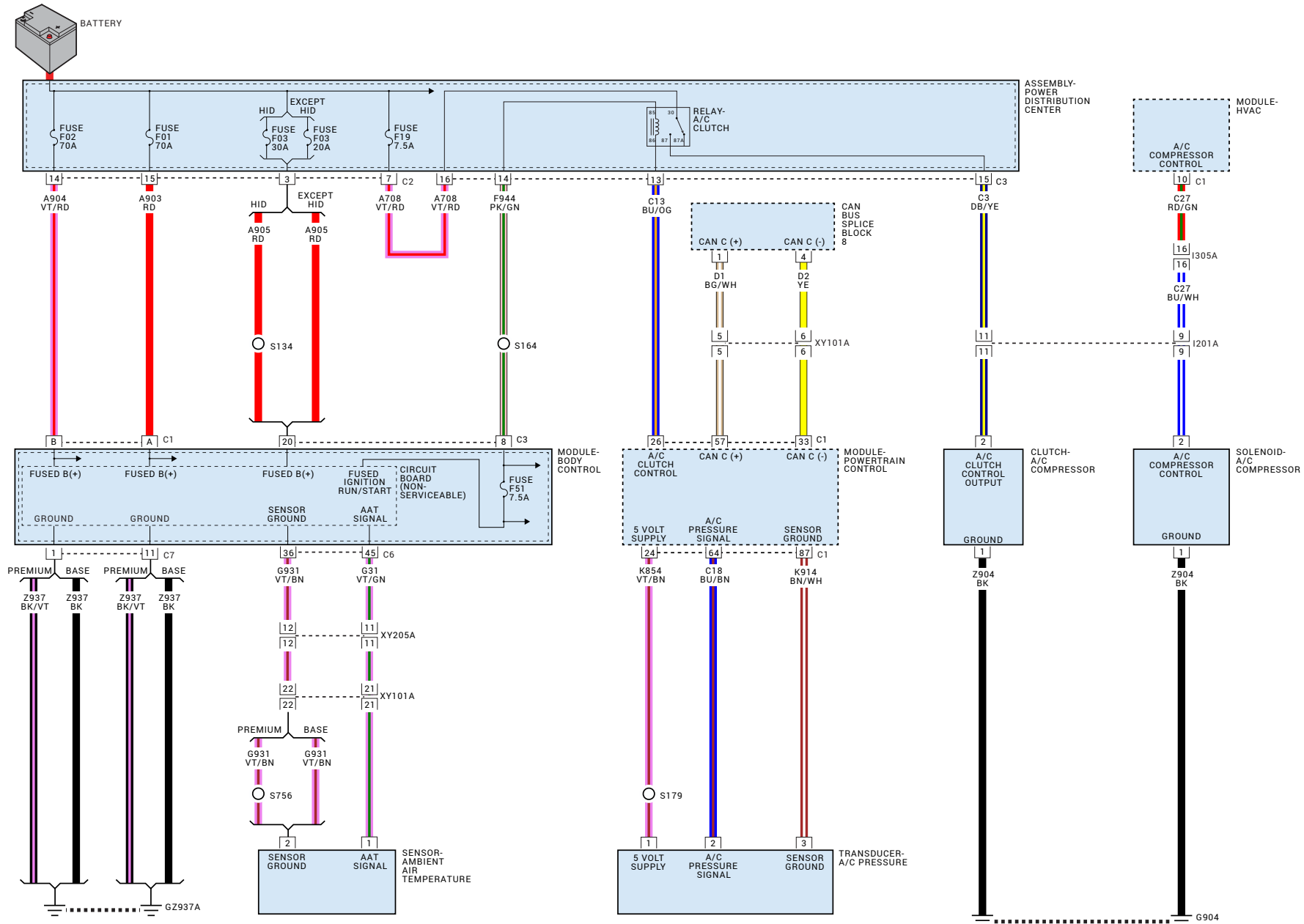

CLICK HERE TO **DOWNLOAD** THE COMPLETE MANUAL

- Thank you very much for reading the preview of the manual.
- You can download the complete manual from: www.heydownloads.com by clicking the link below



- Please note: If there is no response to CLICKING the link, please download this PDF first and then click on it.

CLICK HERE TO **DOWNLOAD** THE COMPLETE MANUAL

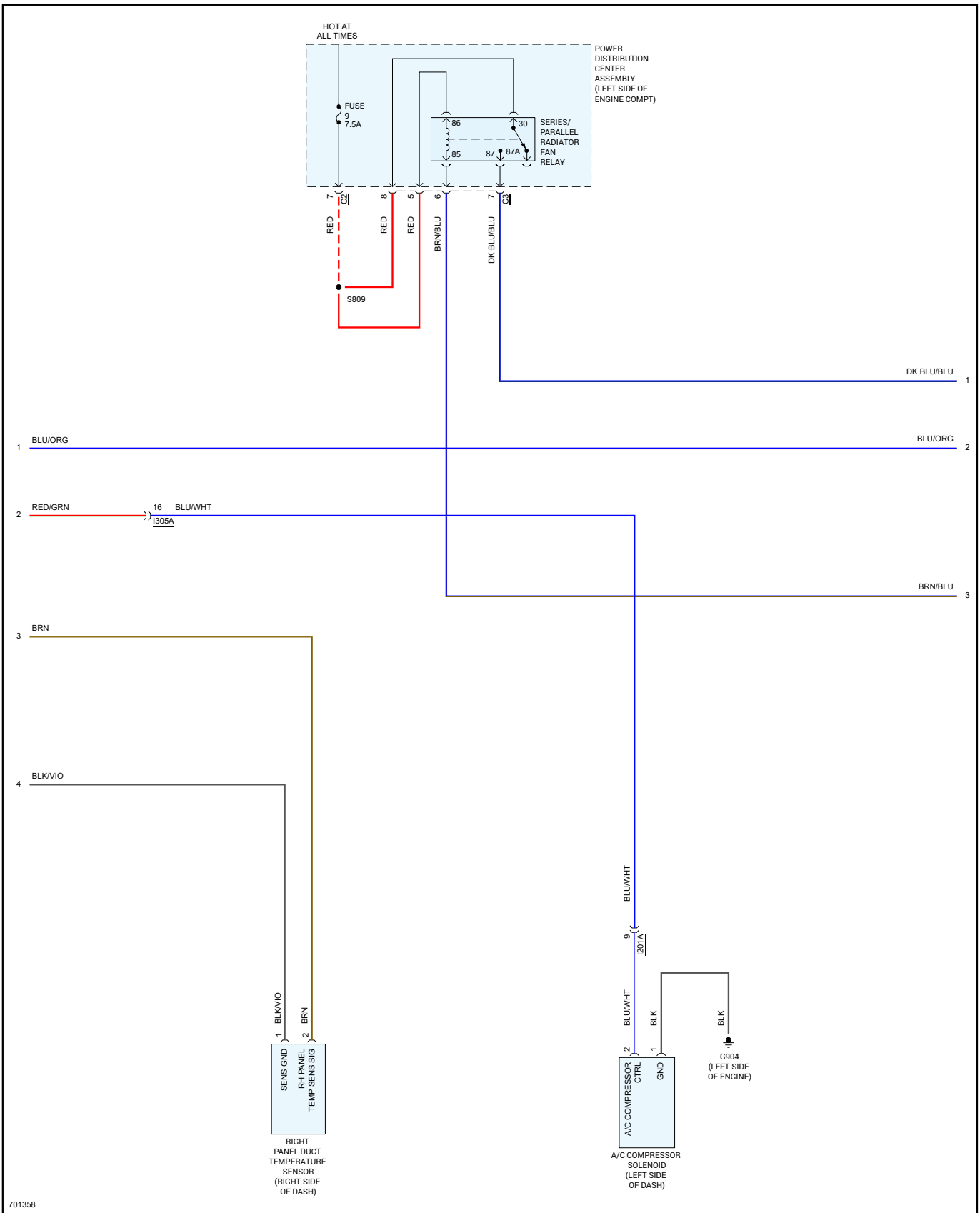

2020 Jeep Truck Compass 4WD L4-2.4L

Vehicle > Heating and Air Conditioning > Diagrams > Electrical - Interactive Color (Non OE)

Air Conditioning - Manual A/C Circuit - Page 5 of 5

2020 Jeep Truck Compass 4WD L4-2.4L

Vehicle > Accessories and Optional Equipment > Collision Avoidance and Parking Assist Systems > Diagrams > Electrical (OE)

BACK-UP CAMERA SYSTEM

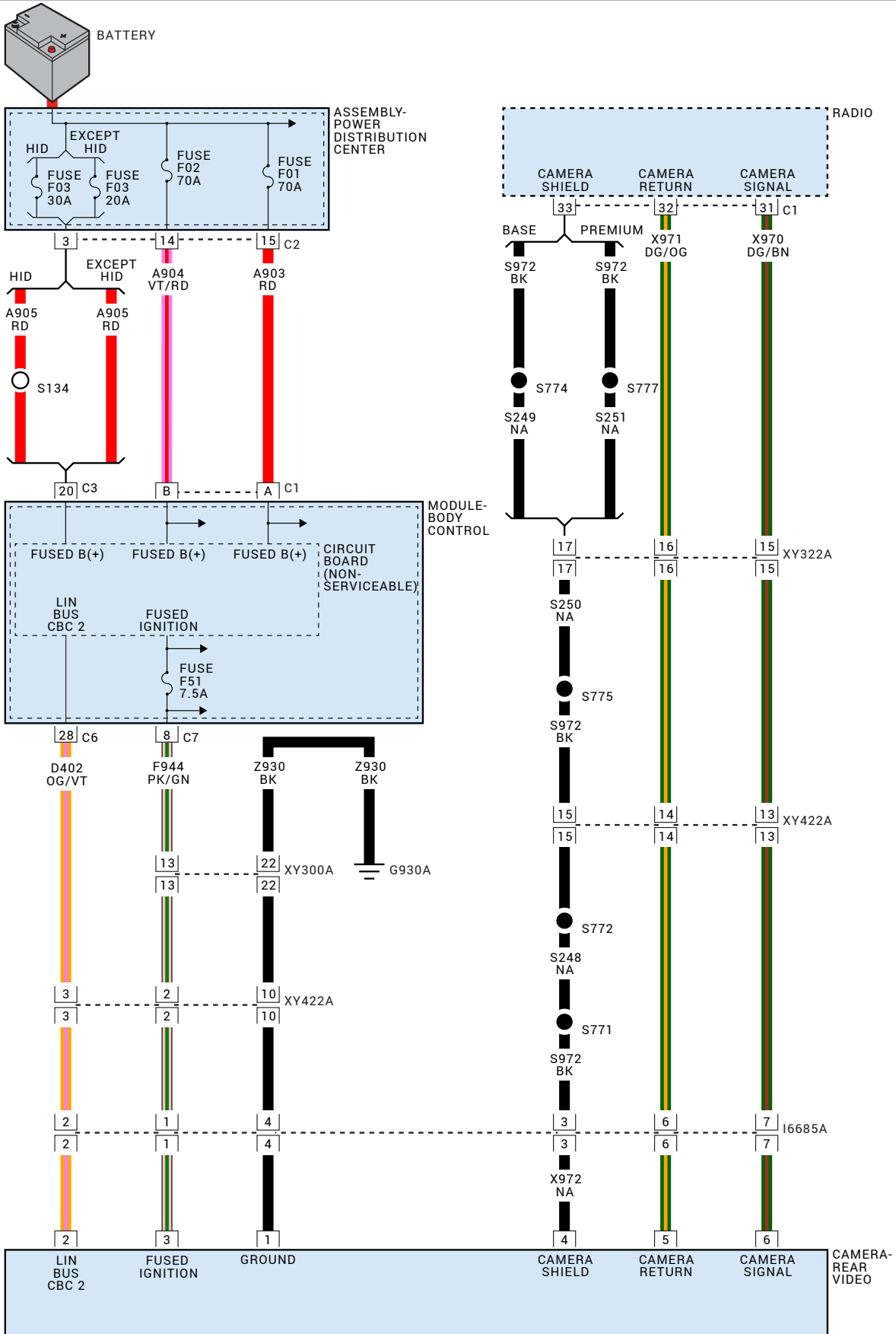

2020 Jeep Truck Compass 4WD L4-2.4L

Vehicle > Powertrain Management > Computers and Control Systems > Information Bus > Diagrams > Electrical (OE)

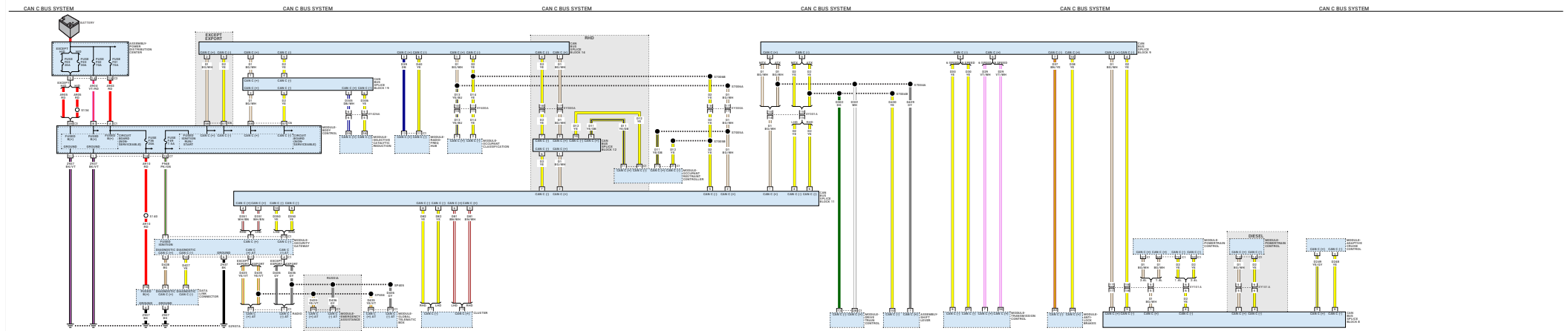

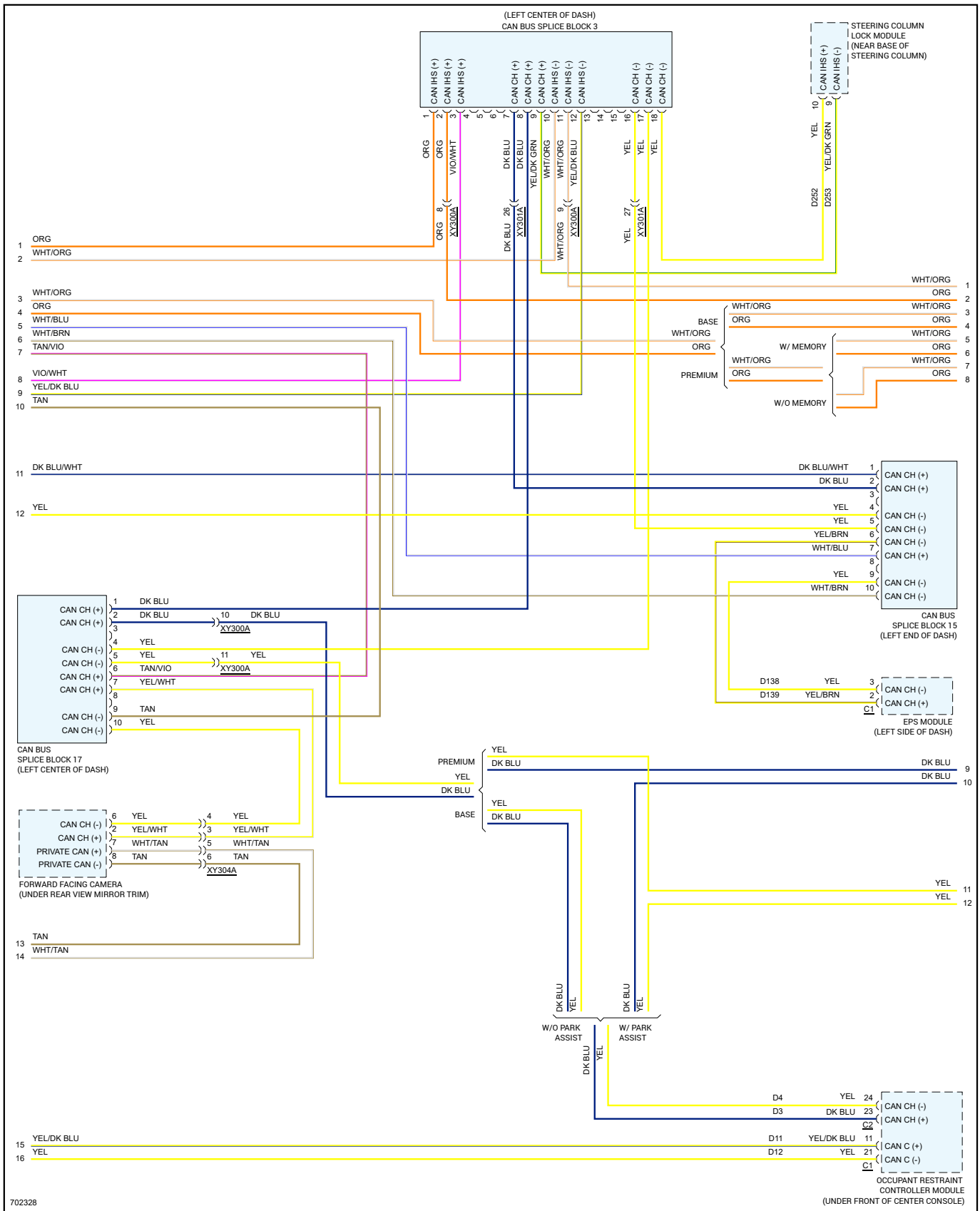

702328

2020 Jeep Truck Compass 4WD L4-2.4L

Vehicle > Powertrain Management > Computers and Control Systems > Information Bus > Diagrams > Electrical - Interactive Color (Non OE)

Computer Data Lines - Page 5 of 5

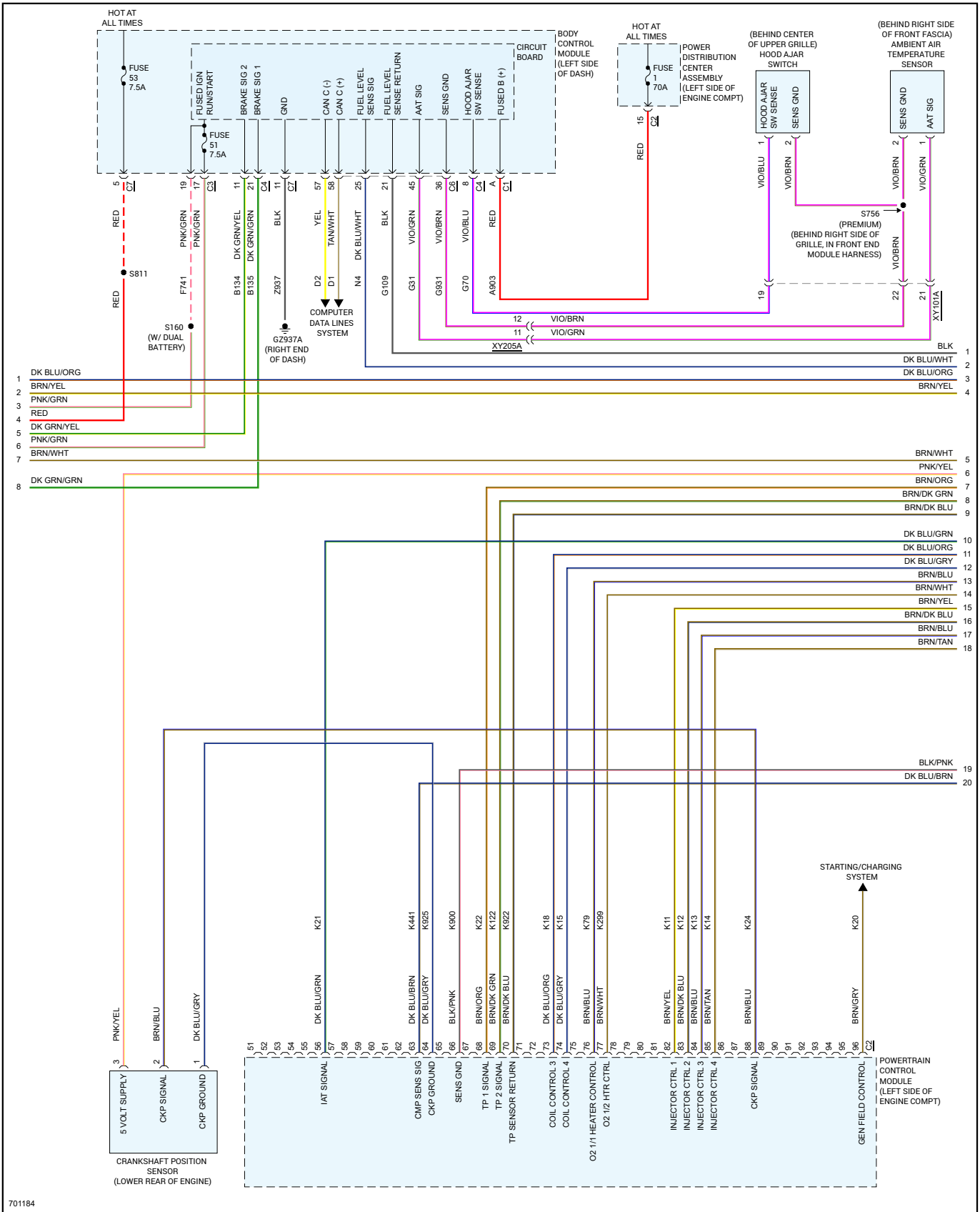

2020 Jeep Truck Compass 4WD L4-2.4L

Vehicle > Accessories and Optional Equipment > Cellular Phone > Communications Control Module > Diagrams > Electrical (OE)

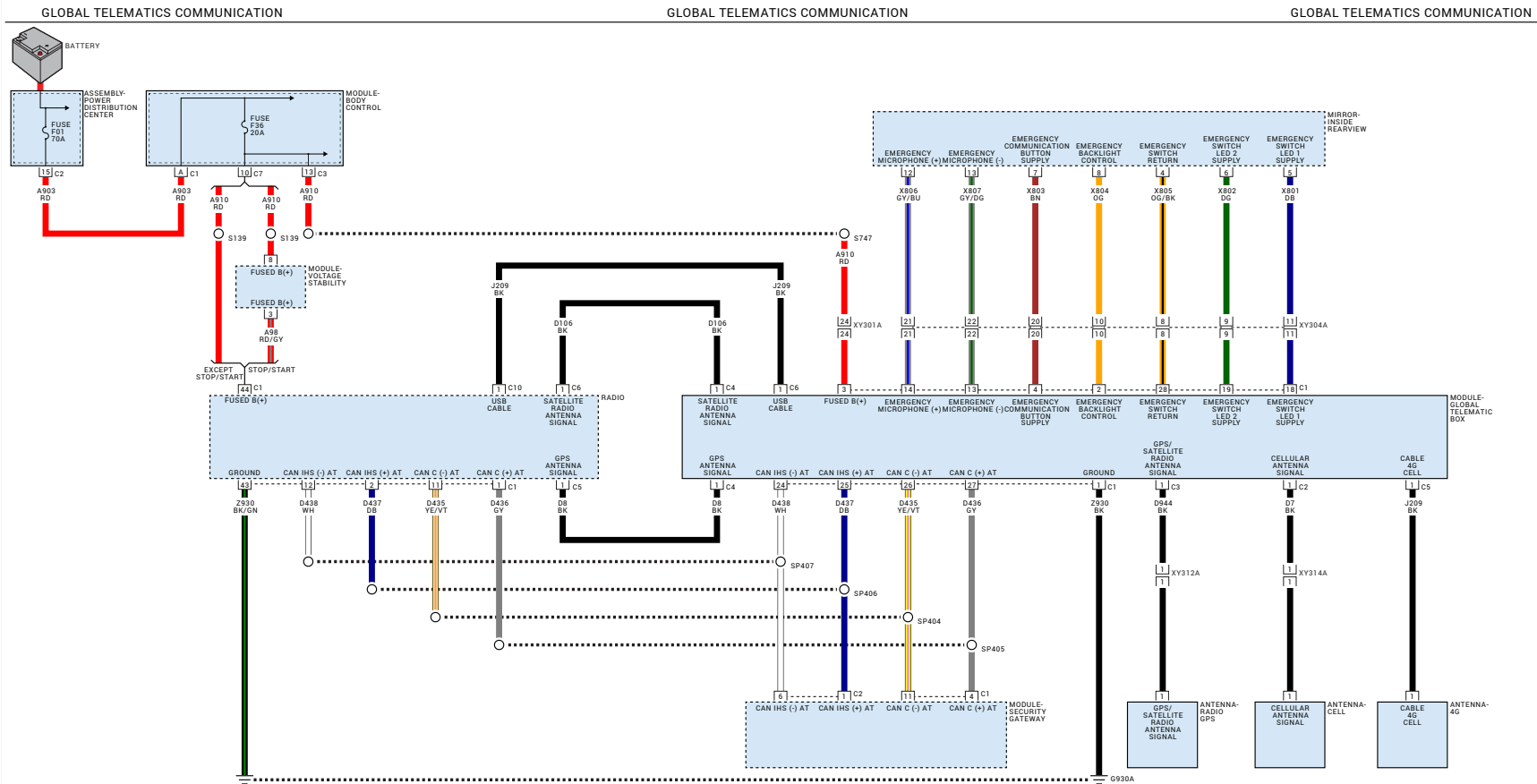

2020 Jeep Truck Compass 4WD L4-2.4L

Vehicle > Power and Ground Distribution > Diagrams > Electrical (OE)

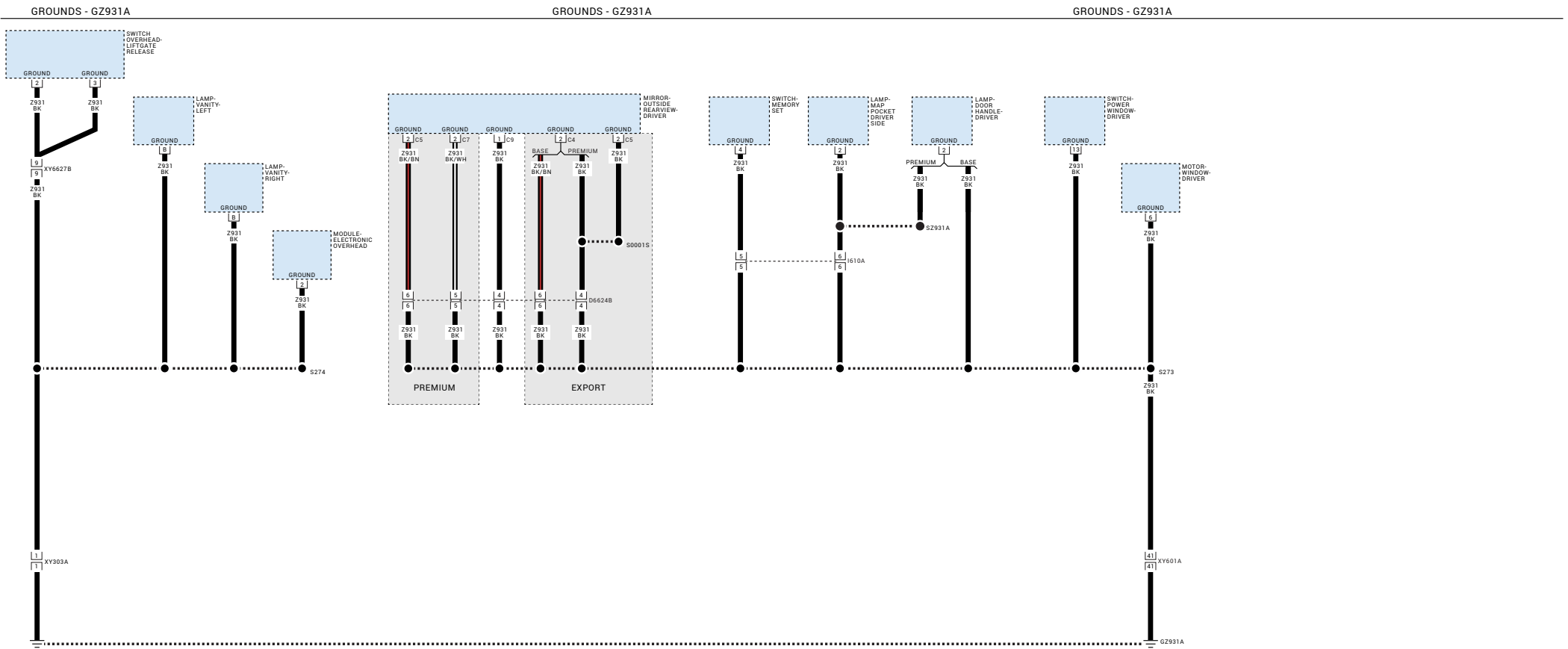

CLICK HERE TO **DOWNLOAD** THE COMPLETE MANUAL

- Thank you very much for reading the preview of the manual.
- You can download the complete manual from: www.heydownloads.com by clicking the link below



- Please note: If there is no response to CLICKING the link, please download this PDF first and then click on it.

CLICK HERE TO **DOWNLOAD** THE COMPLETE MANUAL

2020 Jeep Truck Compass 4WD L4-2.4L

Vehicle > Lighting and Horns > Headlamp > Diagrams > Electrical - Interactive Color (Non OE)

Headlights - W/O HID - Page 1 of 2

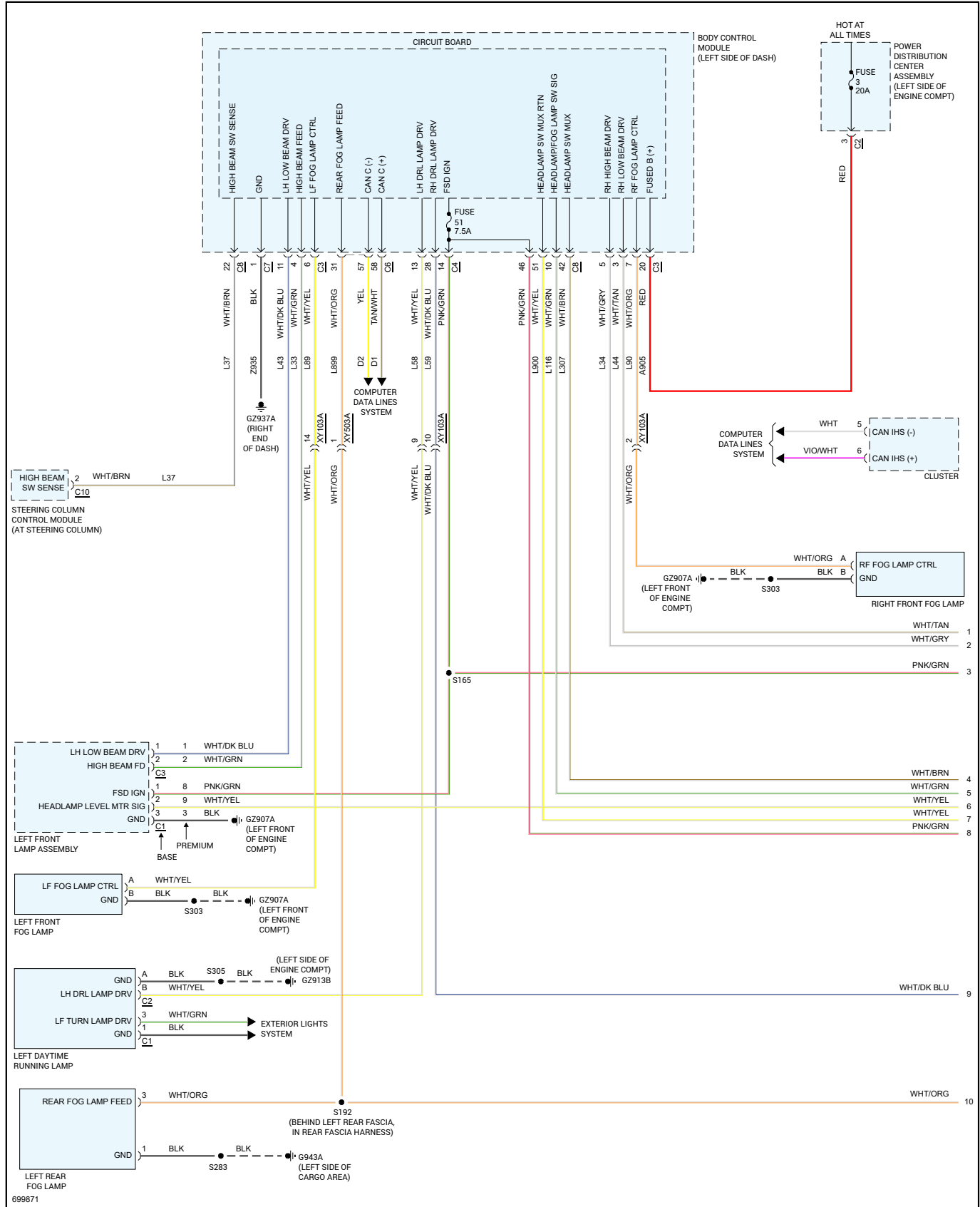

2020 Jeep Truck Compass 4WD L4-2.4L

Vehicle > Lighting and Horns > Headlamp > Diagrams > Electrical - Interactive Color (Non OE)

Headlights - W/O HID - Page 2 of 2

2020 Jeep Truck Compass 4WD L4-2.4L

Vehicle > Heating and Air Conditioning > Diagrams > Electrical (OE)

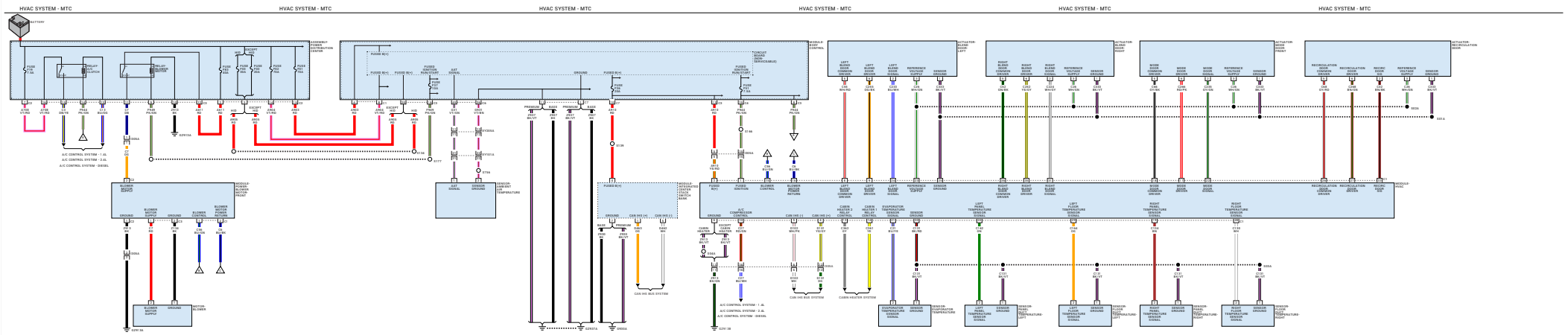

2020 Jeep Truck Compass 4WD L4-2.4L

Vehicle > Accessories and Optional Equipment > Navigation System > Diagrams > Electrical - Interactive Color (Non OE)

Navigation - Blind Spot Monitoring Circuit - Page 1 of 1

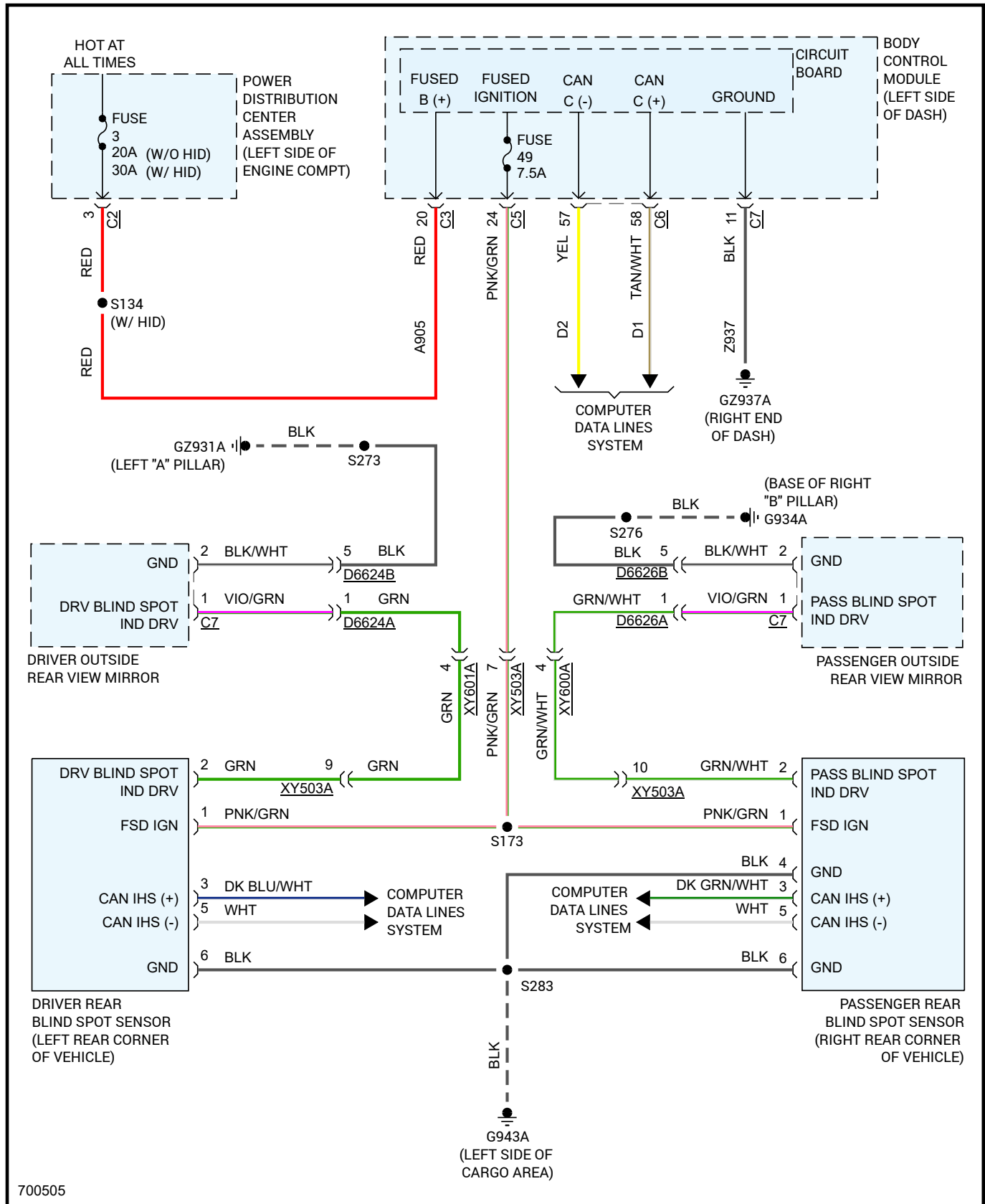

2020 Jeep Truck Compass 4WD L4-2.4L

Vehicle > Brakes and Traction Control > Parking Brake System > Diagrams > Electrical - Interactive Color (Non OE)

Park Brake Release Circuit - Page 1 of 1

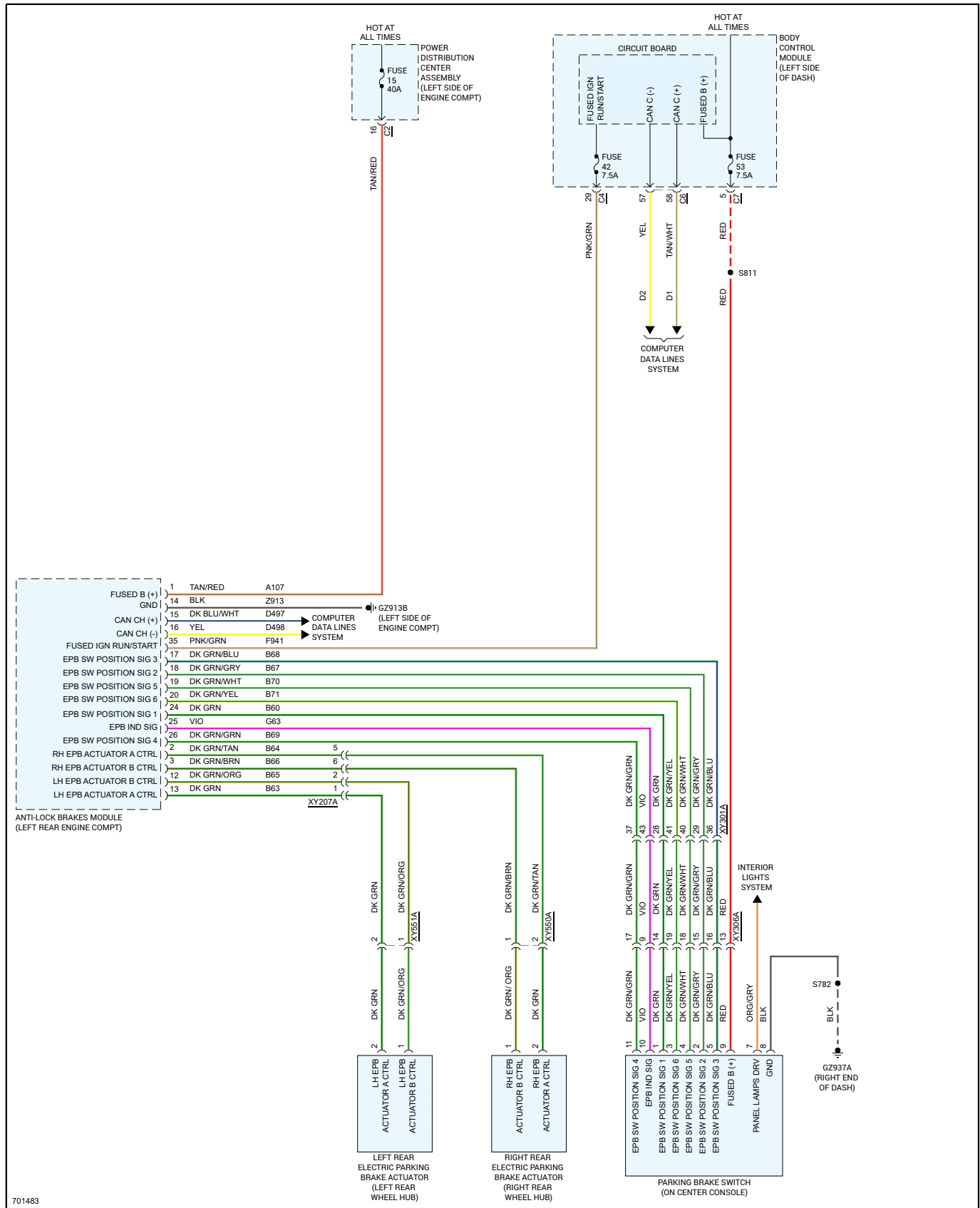

2020 Jeep Truck Compass 4WD L4-2.4L

Vehicle > Body and Frame > Seats > Diagrams > Electrical - Interactive Color (Non OE)

Seats - Driver Power Seat Circuit - Page 1 of 1

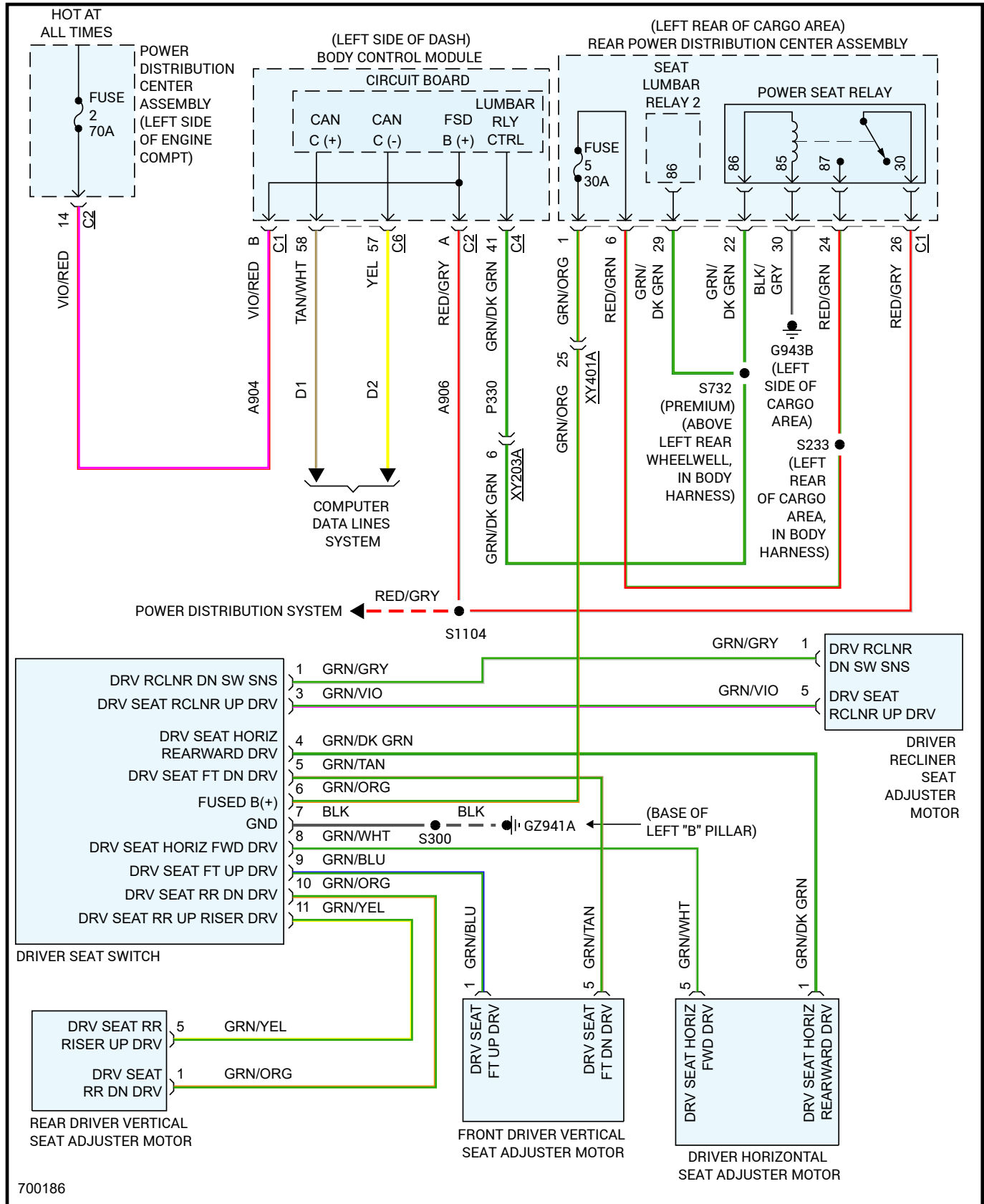

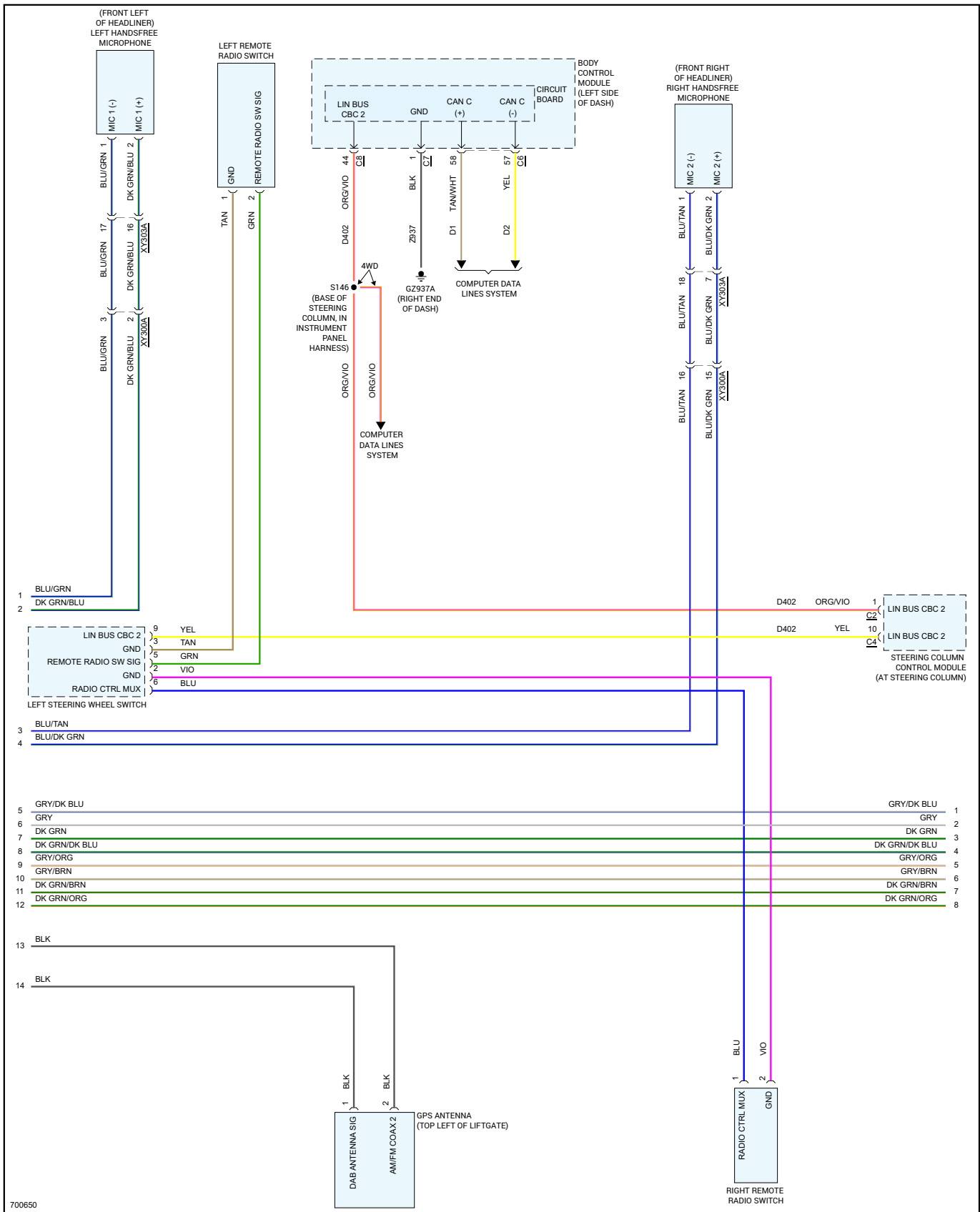

2020 Jeep Truck Compass 4WD L4-2.4L

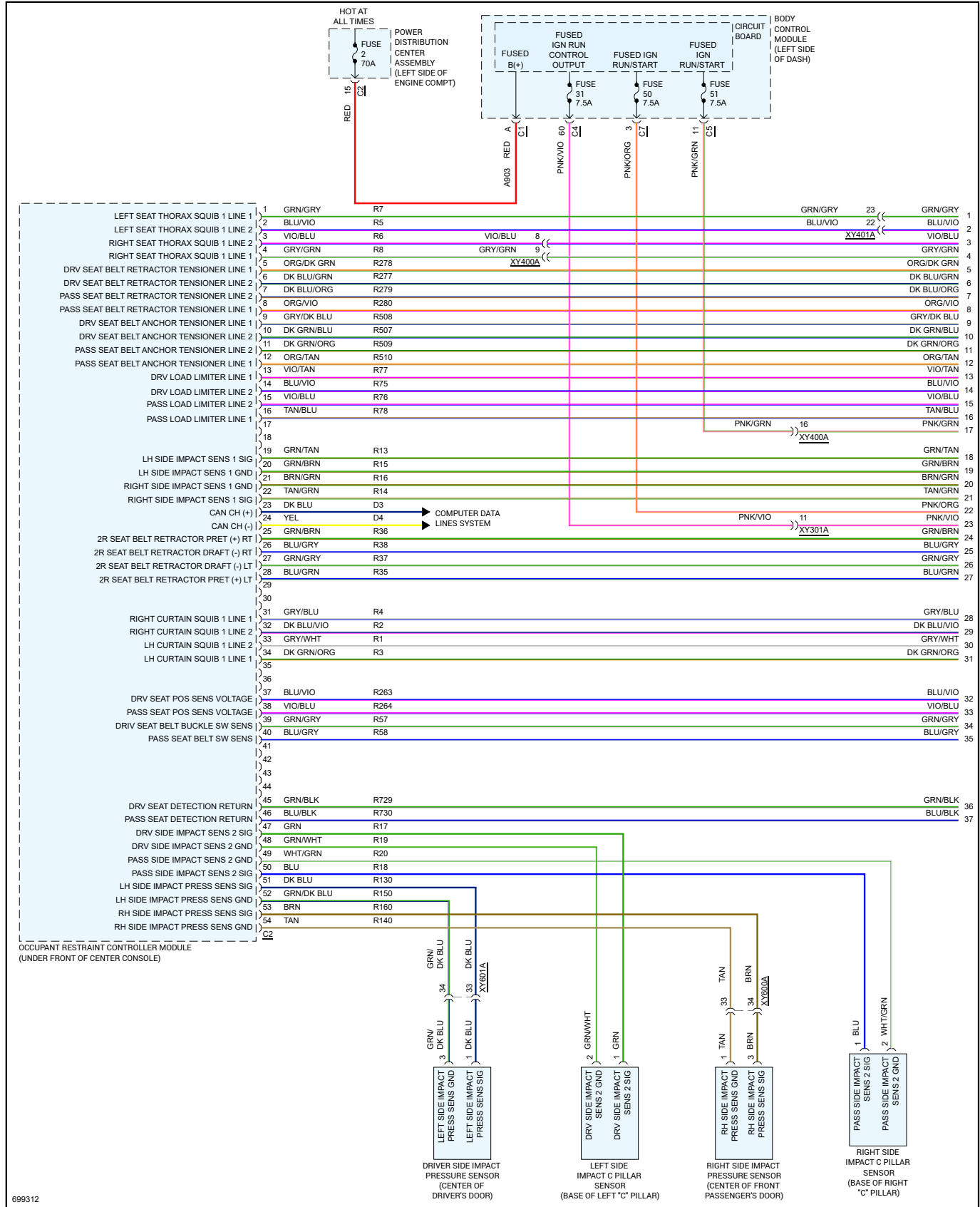

2020 Jeep Truck Compass 4WD L4-2.4L

Vehicle > Transmission and Drivetrain > Automatic Transmission/Transaxle > Diagrams > Electrical (OE)

TRANSMISSION - AISIN F21-250

TRANSMISSION - AISIN F21-250

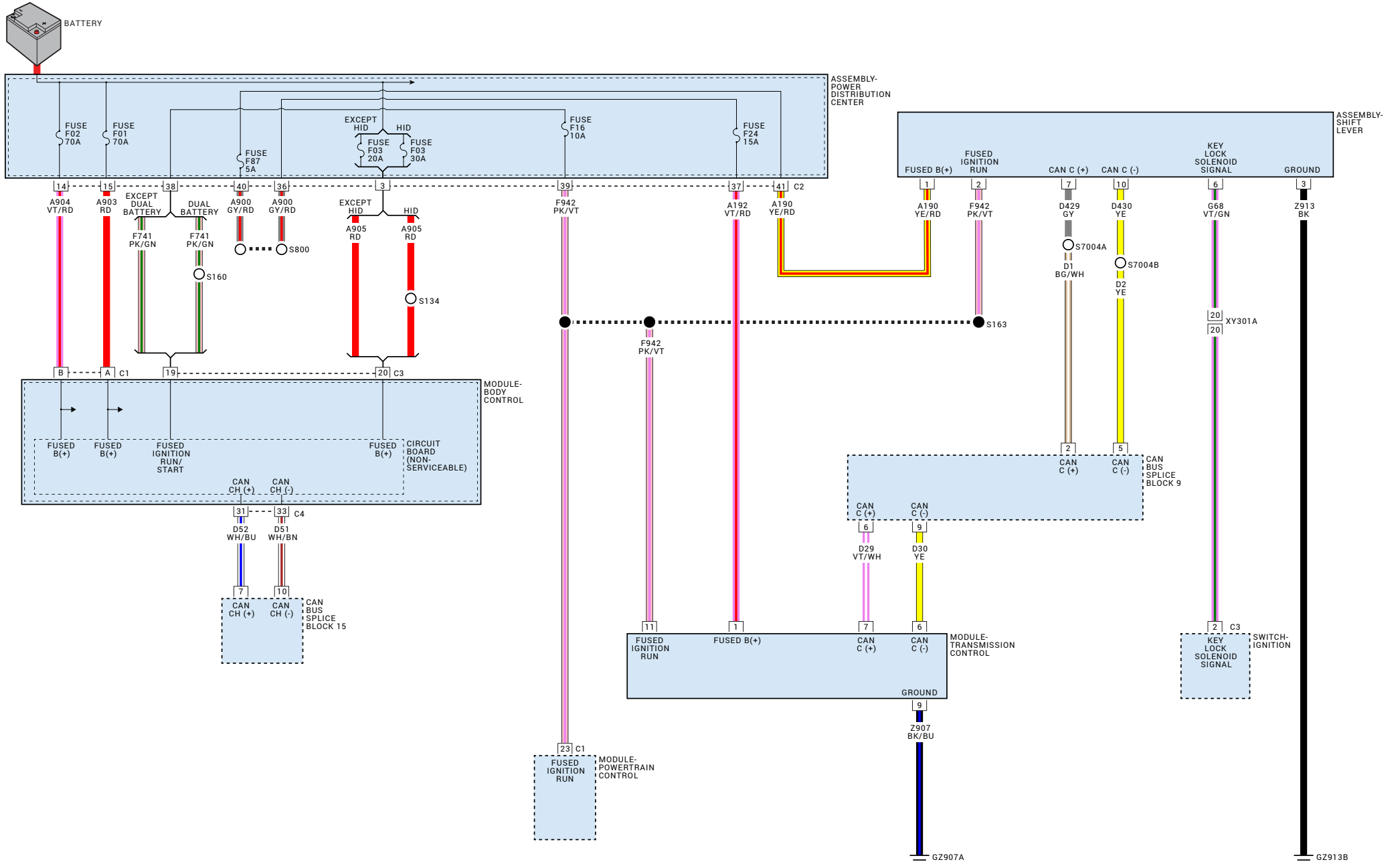

CLICK HERE TO **DOWNLOAD** THE COMPLETE MANUAL

- Thank you very much for reading the preview of the manual.
- You can download the complete manual from: www.heydownloads.com by clicking the link below



- Please note: If there is no response to CLICKING the link, please download this PDF first and then click on it.

CLICK HERE TO **DOWNLOAD** THE COMPLETE MANUAL