

FOREWORD

This wiring diagram manual has been prepared to provide information on the electrical system of the 1999 LAND CRUISER.

Applicable models: UZJ100 Series

For service specifications and repair procedures of the above models other than those listed in this manual, refer to the following manuals;

Manual Name	Pub. No.
● 1999 Land Cruiser Repair Manual Volume 1 Volume 2	RM661U1 RM661U2
● 1999 TOYOTA New Car Features	NCF160U

All information in this manual is based on the latest product information at the time of publication. However, specifications and procedures are subject to change without notice.

TOYOTA MOTOR CORPORATION

NOTICE

When handling supplemental restraint system components (removal, installation or inspection, etc.), always follow the direction given in the repair manuals listed above to prevent accidents and supplemental restraint system malfunction.

CLICK HERE TO **DOWNLOAD** THE COMPLETE MANUAL

- Thank you very much for reading the preview of the manual.
- You can download the complete manual from: www.heydownloads.com by clicking the link below



- Please note: If there is no response to CLICKING the link, please download this PDF first and then click on it.

CLICK HERE TO **DOWNLOAD** THE COMPLETE MANUAL

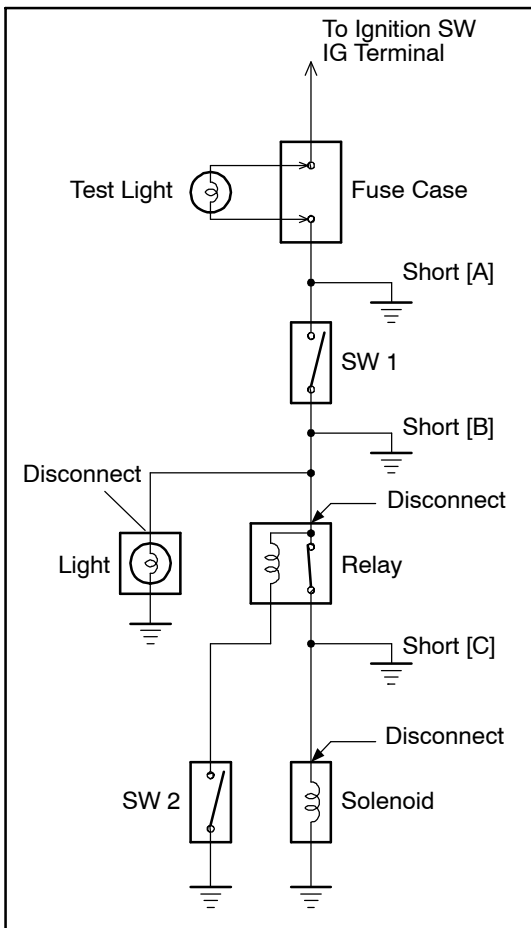

FINDING A SHORT CIRCUIT

- Remove the blown fuse and disconnect all loads of the fuse.
- Connect a test light in place of the fuse.
- Establish conditions in which the test light comes on.

Example:

- [A] - Ignition SW on
- [B] - Ignition SW and SW 1 on
- [C] - Ignition SW, SW 1 and Relay on (Connect the Relay) and SW 2 off (or Disconnect SW 2)

- Disconnect and reconnect the connectors while watching the test light. The short lies between the connector where the test light stays lit and the connector where the light goes out.
- Find the exact location of the short by lightly shaking the problem wire along the body.

CAUTION:

- Do not open the cover or the case of the ECU unless absolutely necessary. (If the IC terminals are touched, the IC may be destroyed by static electricity.)**
- When replacing the internal mechanism (ECU part) of the digital meter, be careful that no part of your body or clothing comes in contact with the terminals of leads from the IC, etc. of the replacement part (spare part).**

DISCONNECTION OF MALE AND FEMALE CONNECTORS

To pull apart the connectors, pull on the connector itself, not the wire harness.

HINT: Check to see what kind of connector you are disconnecting before pulling apart.

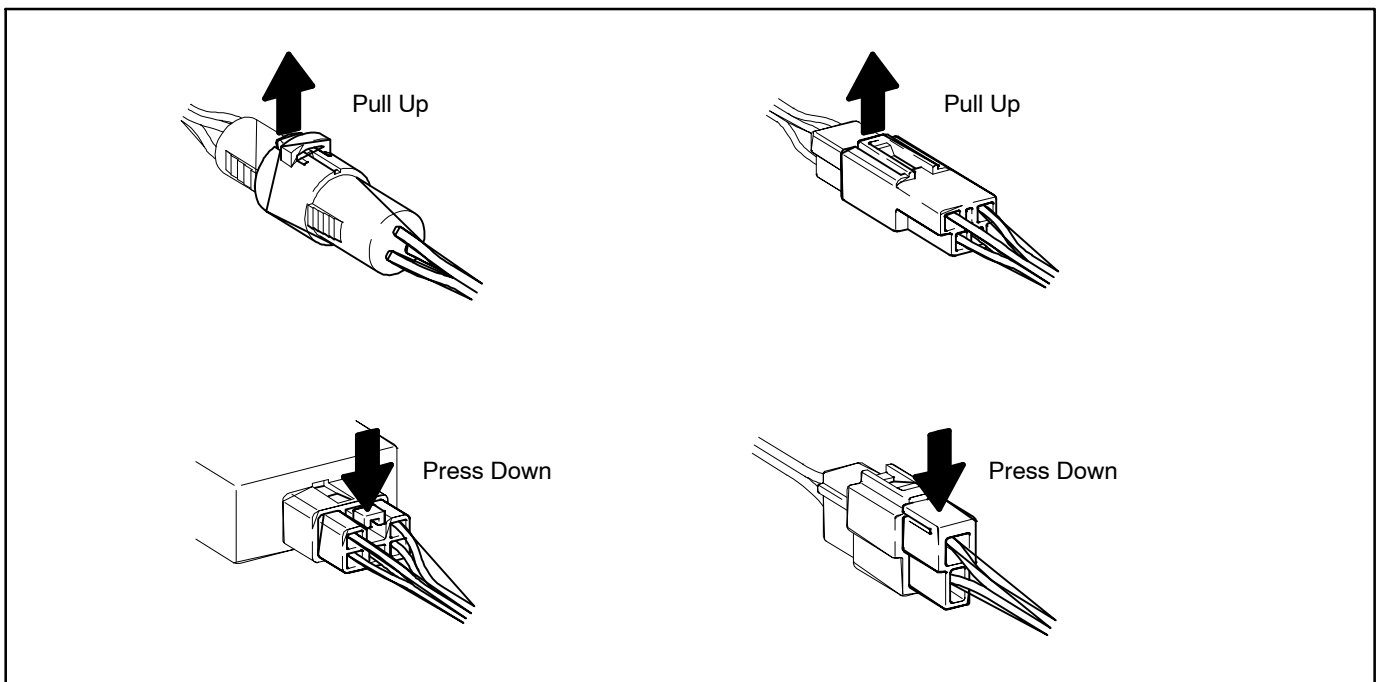

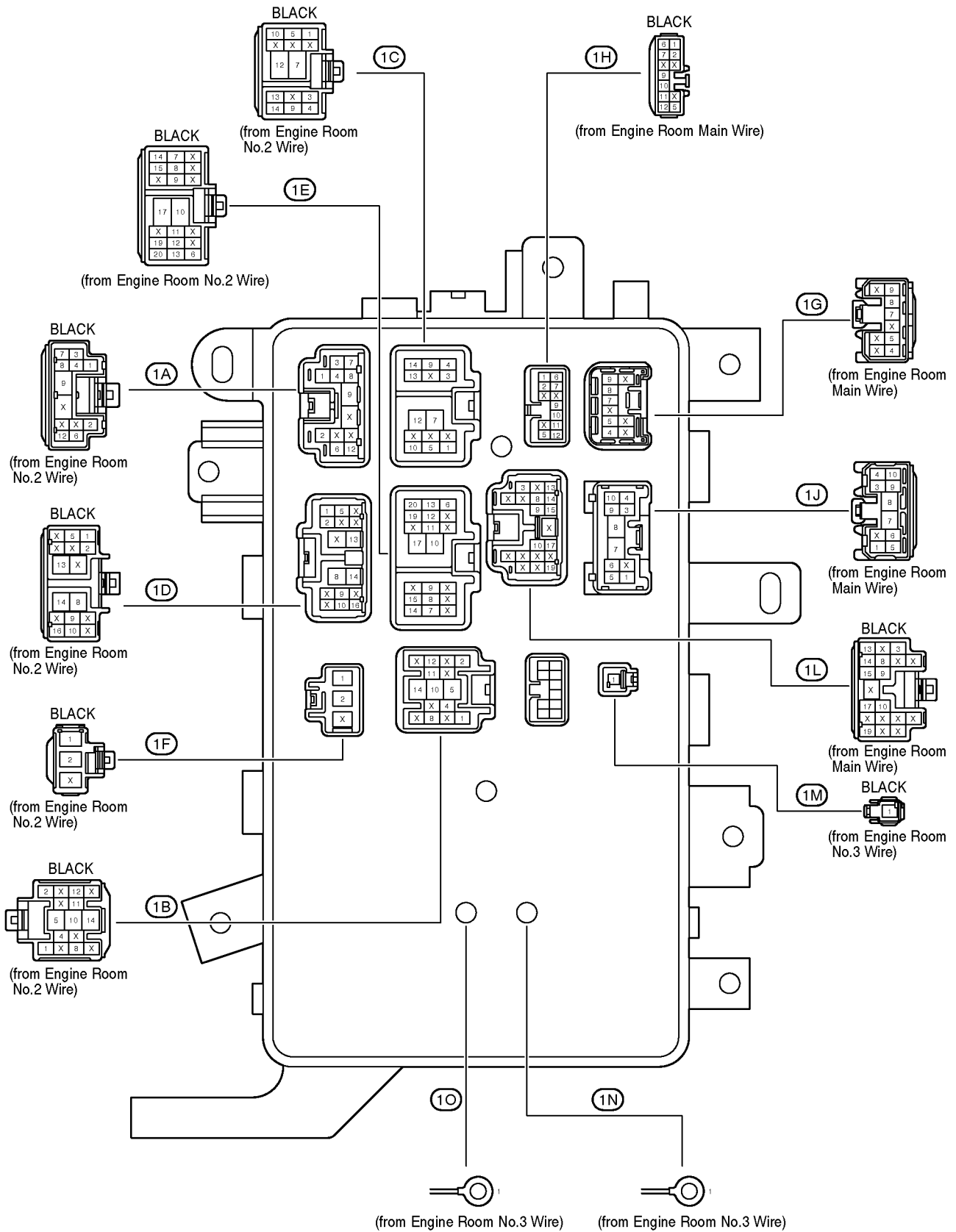

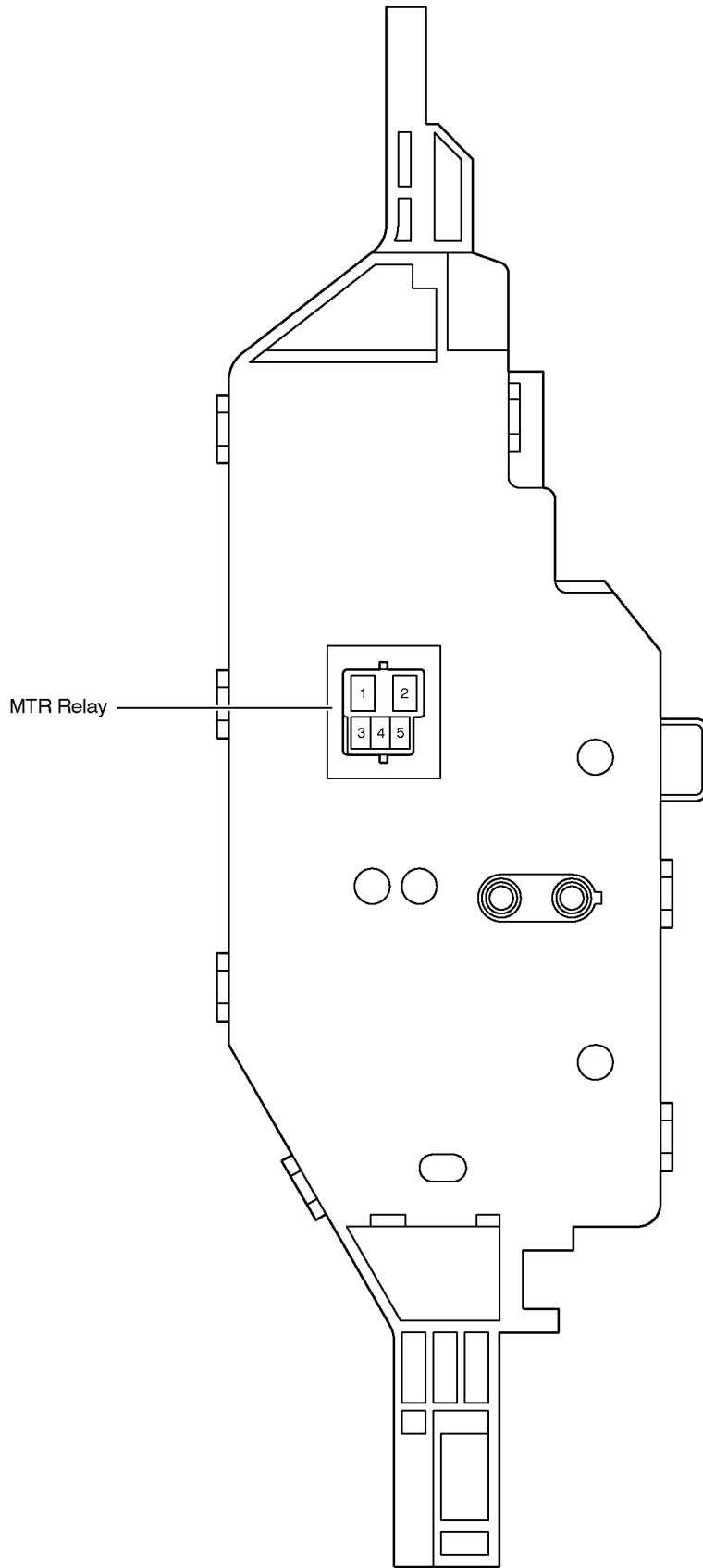

Position of Parts in Body

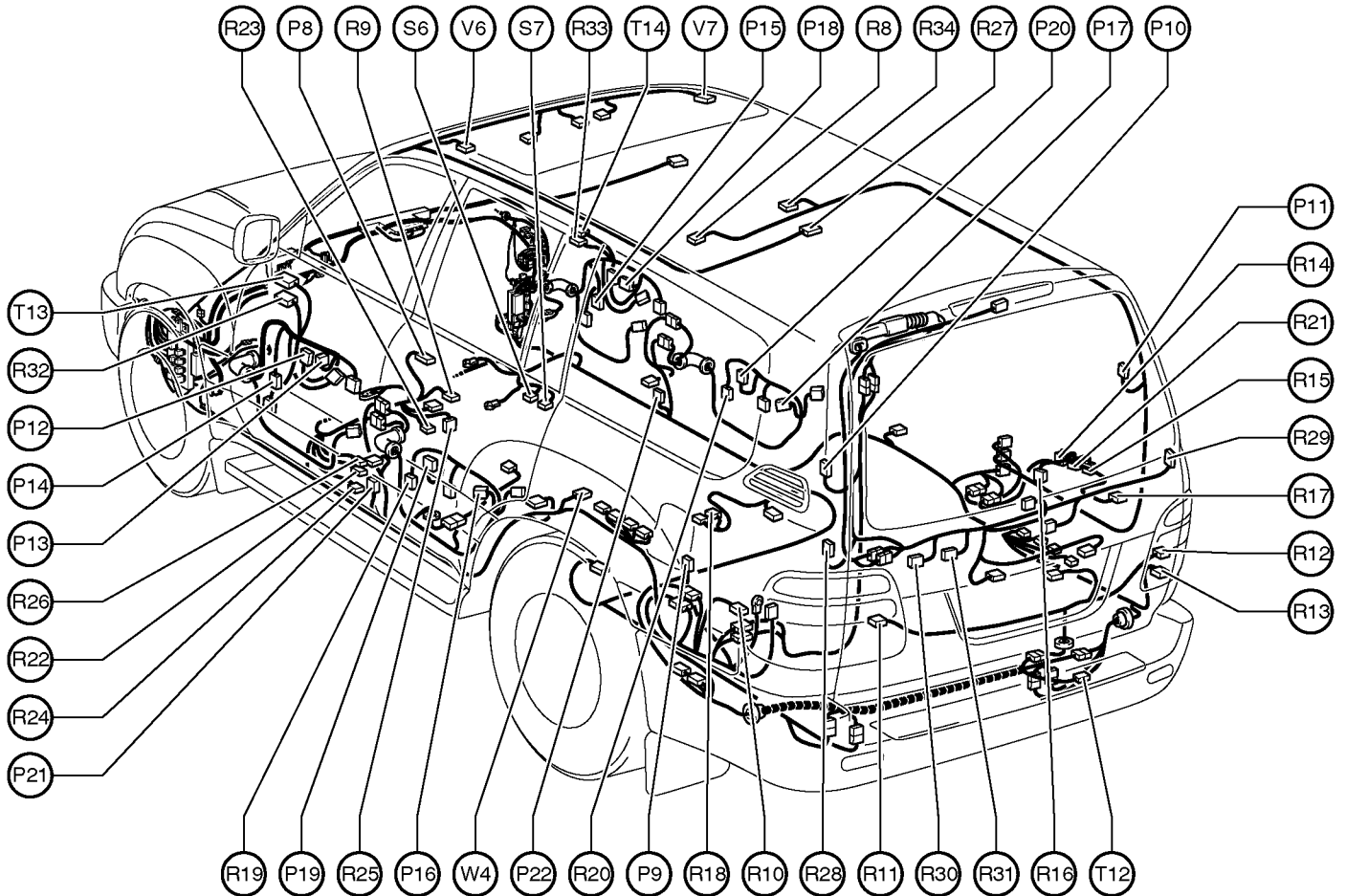

P 8 Parking Brake SW
 P 9 Power Outlet (Luggage Compartment)
 P10 Power Vent Window Motor LH
 P 11 Power Vent Window Motor RH
 P12 Power Window Master SW
 P13 Power Window Master SW
 P14 Power Window Motor Front LH
 P15 Power Window Motor Front RH
 P16 Power Window Motor Rear LH
 P17 Power Window Motor Rear RH
 P18 Power Window SW Front RH
 P19 Power Window SW Rear LH
 P20 Power Window SW Rear RH
 P21 Pretensioner LH
 P22 Pretensioner RH

R20 Rear Door Speaker RH
 R21 Rear Evaporator Temp. Sensor
 R22 Rear Heater Blower Motor
 R23 Rear Heater Blower Resistor
 R24 Rear Heater Fan Relay
 R25 Rear Heater Power Transistor
 R26 Rear Inlet Air Temp. Sensor
 R27 Rear Interior Light
 R28 Rear Window Defogger
 R29 Rear Window Defogger
 R30 Rear Wiper Motor
 R31 Rear Wiper Relay
 R32 Remote Control Mirror LH
 R33 Remote Control Mirror RH
 R34 Room Temp. Sensor (Rear)

R 8 Rear A/C Control SW
 R 9 Rear Air Mix Control Servo Motor
 R10 Rear Combination Light LH
 R11 Rear Combination Light LH
 R12 Rear Combination Light RH
 R13 Rear Combination Light RH
 R14 Rear Cooler Blower Motor
 R15 Rear Cooler Magnetic Valve
 R16 Rear Cooler Power Transistor
 R17 Rear Cooler Relay
 R18 Rear Diff. Lock Motor
 R19 Rear Door Speaker LH

S 6 Stereo Component Amplifier
 S 7 Stereo Component Amplifier
 T 12 Trailer Socket
 T 13 Tweeter LH
 T 14 Tweeter RH
 V 6 Vanity Light LH
 V 7 Vanity Light RH
 W 4 Woofer (Speaker)

Connector Joining Wire Harness and Wire Harness

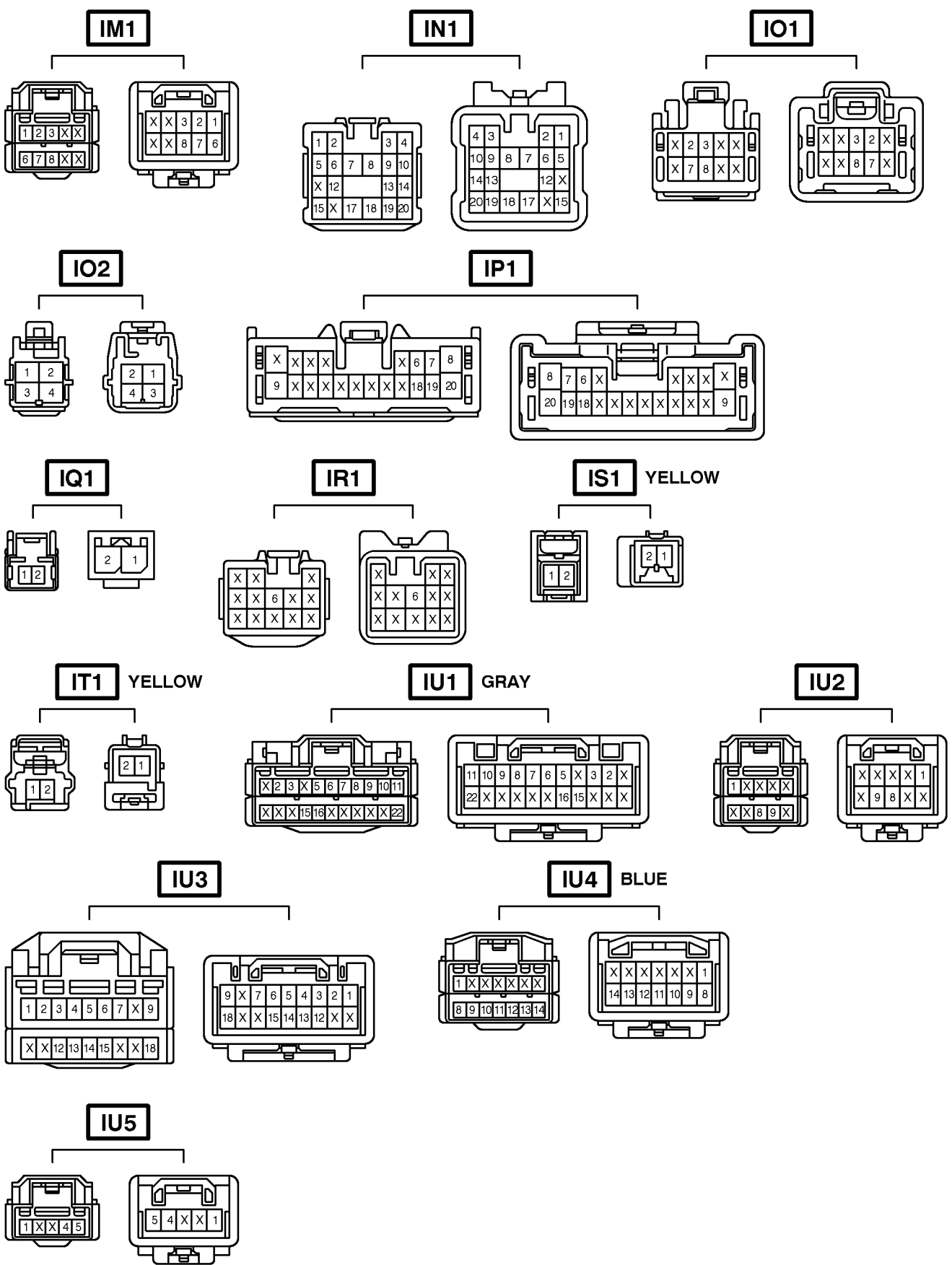

E5

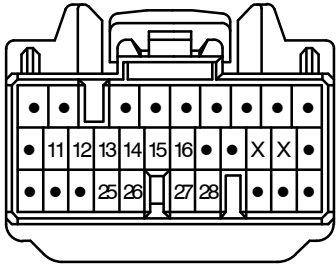

F6

(See Page 34)

I1
BLACK

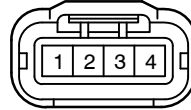

I2
BLACK

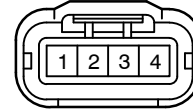

I3
BLACK

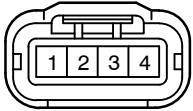

I4
BLACK

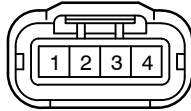

I5
BLACK

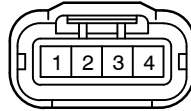

I6
BLACK

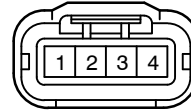

I7
BLACK

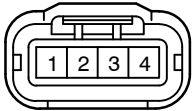

I8
BLACK

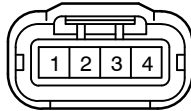

I18

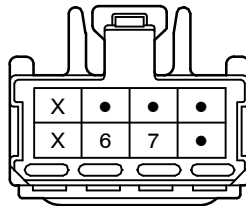

N1
GRAY



2. CONTROL SYSTEM

*** SFI system**

The SFI system monitors the engine condition through the signals input from each sensors to the engine control module. The control signal is sent to the engine control module TERMINALS #1, #2, #3, #4, #5, #6, #7, #8 to operate the injector (Fuel injection). The SFI system controls the fuel injection by the engine control module in response to the driving conditions.

*** ESA system**

The ESA system monitors the engine condition through the signals input from each sensors to the engine control module. The best ignition timing is decided according to this data and the data memorized in the engine control module. The control signal is output to TERMINALS IGT1, IGT2, IGT3, IGT4, IGT5, IGT6, IGT7, IGT8, and these signals control the igniter to provide the best ignition timing.

*** Heated oxygen sensor heater control system**

The heated oxygen sensor heater control system turns the heater on when the intake air volume is low (Temp. of exhaust emission is low), and warms up the heated oxygen sensors to improve their detection performance. The engine control module evaluates the signals from each sensors, and outputs current to TERMINALS HTL, HTR, HTL2, HTR2 to control the heater.

*** Fuel pump control system**

The engine control module supplies current to TERMINAL FPC, and controls the operation speed of the fuel pump with the fuel pump control ECU.

*** ACIS**

The ACIS includes a valve in the bulkhead separating the surge tank into two parts. This valve is opened and closed in accordance with the driving conditions to control the intake manifold length in two stages, for increased engine output in all ranges from low to high speeds.

*** ETCS-i**

The ETCS-i controls the engine output at its optimal level in accordance with the opening of the accelerator pedal, under all driving conditions.

3. DIAGNOSIS SYSTEM

When there is a malfunction in the engine control module signal system, the malfunctioning system is recorded in the memory. The malfunctioning system can be found by reading the code displayed on the malfunction indicator lamp.

4. FAIL-SAFE SYSTEM

When a malfunction has occurred in any system, there is a possibility of causing engine trouble due to continued control based on that system. In that case, the fail-safe system either controls the system using the data (Standard values) recorded in the engine control module memory, or else stops the engine.

SYSTEM OUTLINE

1. DAYTIME RUNNING LIGHT OPERATION

When the engine is started, a signal from the generator is input to daytime running light relay (Main) TERMINAL 11.

At this time, if the parking brake lever is pulled up, the relay does not operate, so the daytime running light system does not operate. When the parking brake lever is released, a signal is input to daytime running light relay (Main) TERMINAL 8. This activates the daytime running light relay (Main), and turns on the DIMMER relay. The current from the battery flows through the fusible link block to DIMMER relay (Point side) to HEAD (LH-UPR) fuse to headlight LH (High) to headlight RH (High) to daytime running light relay No.3 TERMINAL (A) 5 to TERMINAL (A) 3 to GROUND, and the headlights are lit dimmer than usual. Once the daytime running light system is operated, the headlights remain lit even though the parking brake lever is pulled up. The headlights remain lit even when the engine stops with the ignition SW on, and the signal from the generator is cut off. When the ignition SW is turned from on to off, the daytime running light system is canceled and the headlights are turned off. If the engine is started with the parking brake lever released, the daytime running light system operates and the headlights are turned on when the engine starts running.

2. HEADLIGHT OPERATION

* When the light control SW is turned to HEAD position

When the light control SW is turned to HEAD position, the HEAD relay is turned on. At the same time, a signal is input to the daytime running light relay (Main) TERMINAL 5.

As a result, the daytime running light relay (Main) cancels the daytime running light system operation, and turns off the headlight LH, RH (High).

Simultaneously, the current from the battery flows from the fusible link block to HEAD relay (Point side) to HEAD (LH-LWR), HEAD (RH-LWR) fuse to headlight LH, RH (Low) to GROUND, and turns on the headlights at normal brightness.

* When the dimmer SW is turned to HIGH position

When the light control SW is turned to HEAD position, the low beam of the headlights are turned on, and at the same time, current flows from HEAD (RH-LWR) fuse to daytime running light relay No.3 (Coil side) to GROUND, and turns on the daytime running light relay No.3.

When the dimmer SW is turned to HIGH position, a signal is input to daytime running light relay (Main) TERMINAL 16. This activates the DIMMER relay, and the current from the battery flows from the fusible link block to DIMMER relay (Point side) to HEAD (LH-UPR) fuse to headlight LH (High) to daytime running light relay No.3 TERMINAL (B) 2 to TERMINAL (B) 1 to GROUND. At the same time the current flows from DIMMER relay (Point side) to HEAD (RH-UPR) fuse to daytime running light relay No.3 TERMINAL (A) 2 to TERMINAL (A) 5 to headlight RH (High) to daytime running light relay No.3 TERMINAL (B) 2 to TERMINAL (B) 1 to GROUND. Also current flows from the daytime running light relay No.3 TERMINAL (A) 3 to TERMINAL (A) 5 to combination meter TERMINAL 4 to TERMINAL 2 to GROUND. As a result the headlight high beam, low beam, and high beam indicator light are turned on simultaneously.

* When the dimmer SW is turned to FLASH position

When the dimmer SW is turned to FLASH position, the HEAD relay is turned on, the daytime running light system is canceled and the daytime running light relay No.3 is turned on, as when the light control SW is turned to HEAD position. At the same time, the DIMMER relay is turned on as when the dimmer SW is turned to HIGH position. As a result, the headlight high beam, low beam, and high beam indicator light are turned on simultaneously.

SERVICE HINTS

HEAD RELAY

1-2 : Closed with light control SW at **HEAD** position or dimmer SW at **FLASH** position

DIMMER RELAY

1-2 : Closed with daytime running light operation

: Closed with light control SW at **HEAD** position and dimmer SW at **HIGH** position

: Closed with dimmer SW at **FLASH** position

C16 COMBINATION SW

13-16 : Closed with light control SW at **HEAD** position

8-16 : Closed with dimmer SW at **FLASH** position

7-16 : Closed with dimmer SW at **HIGH** or **FLASH** position

FROM POWER SOURCE SYSTEM (SEE PAGE 62)

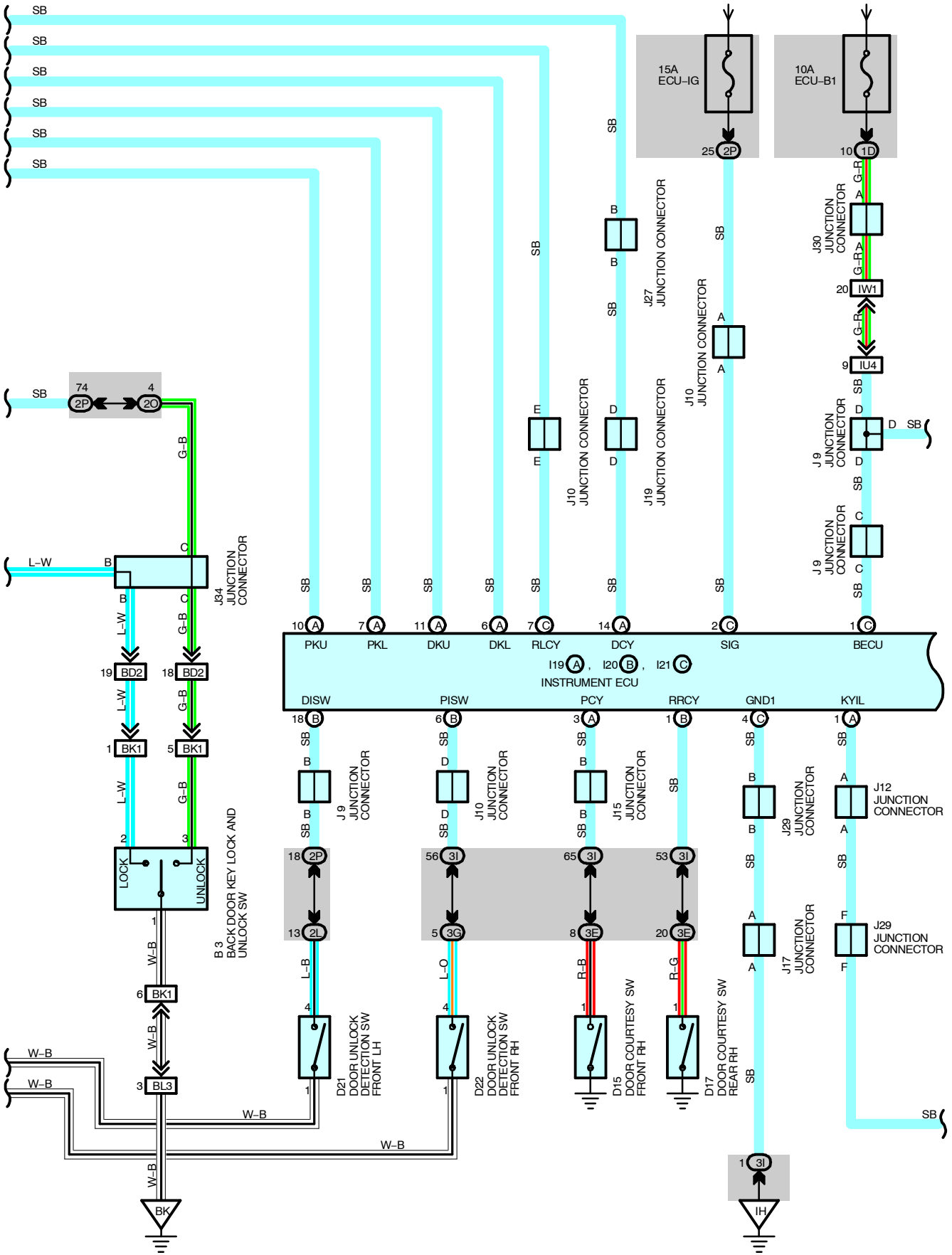

SERVICE HINTS

C9 CLOCK [CENTER ECU]

- 2-GROUND : Approx. **12** volts with ignition SW at **ACC** or **ON** position
- 12-GROUND : Always approx. **12** volts
- 22-GROUND : Always continuity

○ : PARTS LOCATION

Code	See Page	Code	See Page	Code	See Page
C9	38	J1	39		

○ : JUNCTION BLOCK AND WIRE HARNESS CONNECTOR

Code	See Page	Junction Block and Wire Harness (Connector Location)
2B	24	Dash Wire and Cowl Side J/B LH (Left Kick Panel)
2D		

▽ : GROUND POINTS

Code	See Page	Ground Points Location
IF	46	Set Bolt of Cowl Side J/B LH

C9

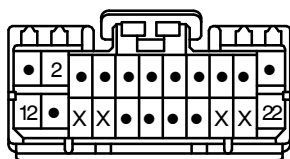

J1

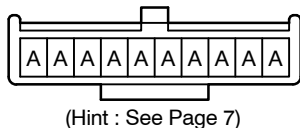

(Hint : See Page 7)

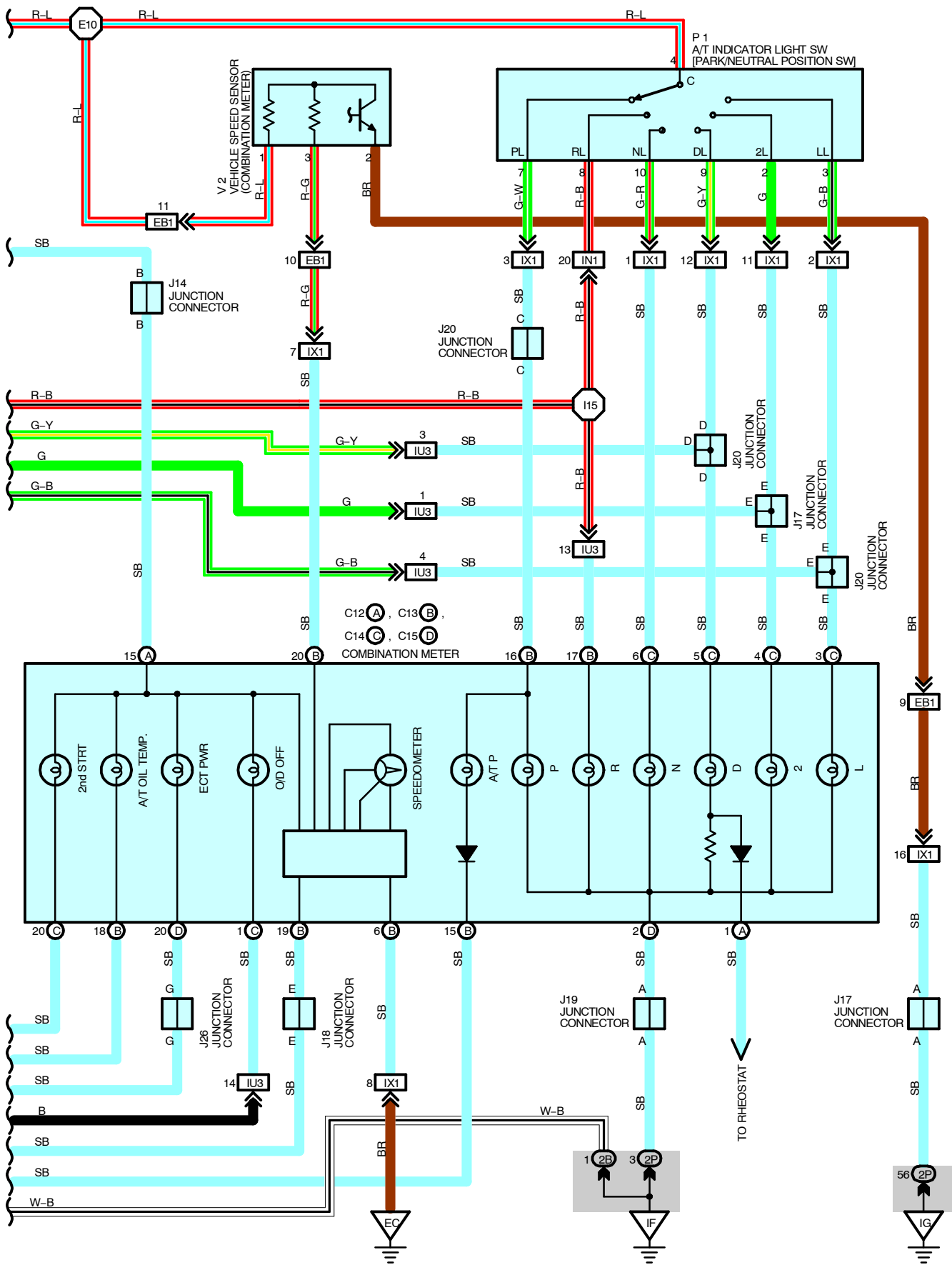

SYSTEM OUTLINE

The cruise control system is a constant vehicle speed controller which controls the opening angle of the engine throttle valve by the SW, and allows driving at a constant speed without depressing the accelerator pedal.

SET OPERATION

When the CRUISE SW is turned on, the systems starts preparations for cruise control and turns on the indicator light in the combination meter.

SET SPEED CONTROL

When the SET/COAST SW is operated with the CRUISE SW turned on during driving, the speed is controlled at a constant speed.

COAST CONTROL

When the SET/COAST SW is kept turned on during cruise control driving, the engine control module controls the throttle valve to decelerate the vehicle speed.

Every time the SET/COAST SW is turned on instantaneously, the vehicle speed is decelerated approx. 1.5 km/h.

ACCEL CONTROL

When the RES/ACC SW is kept turned on during cruise control driving, the engine control module controls the throttle valve to accelerate the vehicle speed.

Every time the SET/COAST SW is turned on instantaneously, the vehicle speed is accelerated approx. 1.5 km/h.

RESUME CONTROL

If the vehicle speed is within the low speed limit (Approx. 40 km/h, 25 mph) when canceling the cruise control, operation of the RES/ACC SW accelerates the vehicle speed and resumes the level before canceling the cruise control.

MANUAL CANCEL MECHANISM

If any of the following signals are input during cruise control driving, the cruise control is canceled.

- * The stop light SW is on
- * The CANCEL SW is turned on
- * The CRUISE SW is turned off

AUTO CANCEL FUNCTION

If any of the following conditions are detected, the cruise control is canceled:

- * Failure in the stop light SW wiring
- * Abnormality in the vehicle speed signal
- * Malfunction in the electronically controlled throttle parts

OVERDRIVE FUNCTION

The overdrive may be canceled if the vehicle travels on a upward slope during cruise control driving. After the overdrive is canceled, if the vehicle speed exceeds the overdrive return speed (Set speed (2 km/h, 1.2 mph)) and it is determined that the slope has finished, and the vehicle returns to overdrive mode again.

SERVICE HINTS

E5 (A), E6 (B), E8 (D), E9 (E) ENGINE CONTROL MODULE

IGSW-E1 : 9.0-14.0 volts with ignition SW at ON or ST position

BATT-E1 : Always approx. 9.0-14.0 volts

STP-E1 : Approx. 12 volts with stop light SW at on

: Below 1.5 volts with brake pedal is released

C18 CRUISE CONTROL SW [COMB. SW]

4-3 : Approx. 418 Ω with CANCEL SW on

: Approx. 198 Ω with SET/COAST SW on

: Approx. 68 Ω with RES/ACC SW on

CLICK HERE TO **DOWNLOAD** THE COMPLETE MANUAL

- Thank you very much for reading the preview of the manual.
- You can download the complete manual from: www.heydownloads.com by clicking the link below



- Please note: If there is no response to CLICKING the link, please download this PDF first and then click on it.

CLICK HERE TO **DOWNLOAD** THE COMPLETE MANUAL

C13 (B)

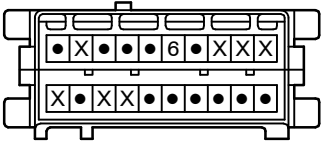

C15 (D)

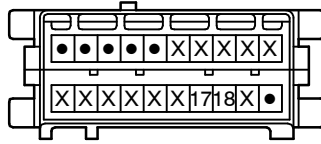

**D1
BLACK**

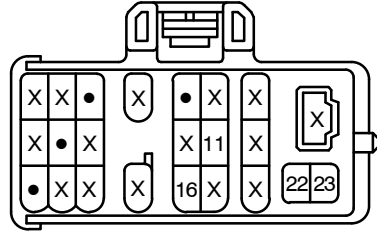

**D7
BLACK**

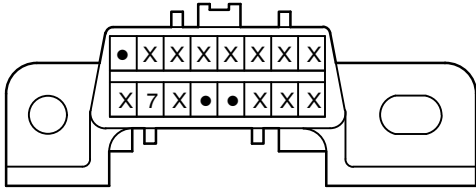

J2

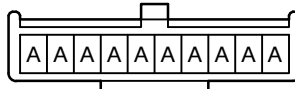

(Hint : See Page 7)

**J5
BLACK**

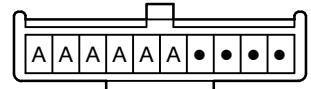

(Hint : See Page 7)

**J7
GREEN**

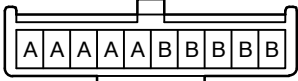

(Hint : See Page 7)

J14

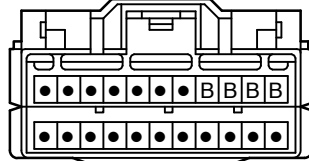

(Hint : See Page 7)

**J19
GRAY**

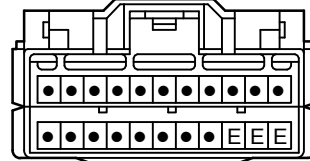

(Hint : See Page 7)

**J21
BLUE**

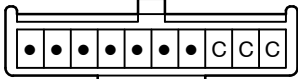

(Hint : See Page 7)

**J22
RED**

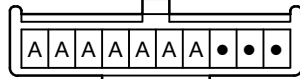

(Hint : See Page 7)

J28

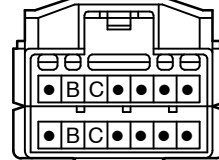

(Hint : See Page 7)

**J35
GREEN**

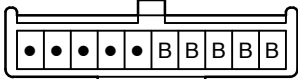

(Hint : See Page 7)

**J36
GREEN**

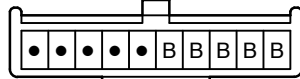

(Hint : See Page 7)

P8



**S5
BLUE**

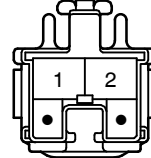

FROM POWER SOURCE SYSTEM (SEE PAGE 62)

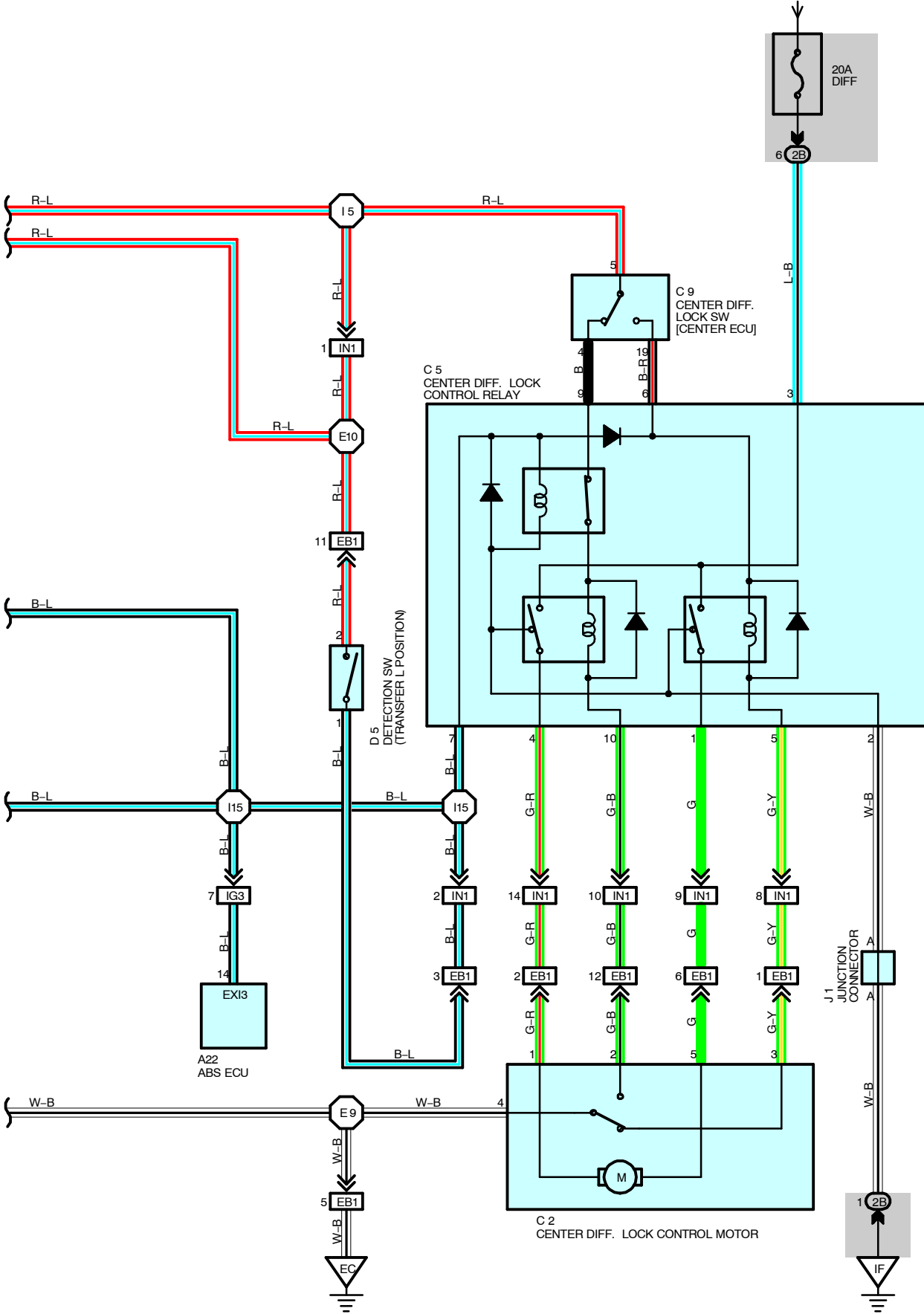

SYSTEM OUTLINE

1. MANUAL DOWN OR UP OPERATION (DRIVER'S SIDE)

When the power window master SW is pressed one step, the current flows from the power window master SW TERMINAL DD to power window motor front LH to power window master SW TERMINAL DU to GROUND, and rotates the motor to open the window.

When the power window master SW is pulled one step, the current flows from the power window master SW TERMINAL DU to power window motor front LH to power window master SW TERMINAL DD to GROUND, and rotates the motor to close the window.

For the other windows, as the power window master SW and power window SW is operated, the relevant door window is opened or closed.

2. AUTO DOWN OR UP OPERATION (DRIVER'S SIDE)

When the power window master SW is pushed two steps, the power window master SW determines it is in auto mode and the current flows from the power window master SW TERMINAL DD to power window motor front LH to power window master SW TERMINAL DU to GROUND, and rotates the motor to open the window automatically.

When the power window master SW is pulled two steps, the power window master SW determines it is in auto mode and the current flows from the power window master SW TERMINAL DU to power window motor front LH to power window master SW TERMINAL DD to GROUND, and rotates the motor to close the window automatically.

3. CATCHING PREVENTION FUNCTION (DRIVER'S SIDE)

When any foreign matter is caught in the window during power window up operation, the pulse sensor in the power window motor detects the changes in the number of motor rotations and forcibly opens the door window 50 mm, or when the window opening is less than 200 mm, it opens the window until the opening is 200 mm.

4. KEY OFF POWER WINDOW OPERATION

It is possible to operate the power window for approx. 43 seconds after the ignition SW is turned from on to off. However, when the door is opened while the window is being operated, the power window operation is stopped even though 43 seconds have not elapsed.

SERVICE HINTS

P12 POWER WINDOW MASTER SW

3-GROUND : Always approx. 12 volts

10-GROUND : Approx. 12 volts with ignition SW at **ON** or **ST** position
: Approx. 12 volts with key off power window operation

4, 5-GROUND : Always continuity

1-GROUND : Continuity with power window master SW at **MANUAL UP** position
: Continuity with power window master SW at **AUTO UP** position

2-GROUND : Continuity with power window master SW at **MANUAL DOWN** position
: Continuity with power window master SW at **AUTO DOWN** position

WINDOW LOCK SW

Open with the window lock SW at lock position

○ : PARTS LOCATION

Code	See Page	Code	See Page	Code	See Page
D14	40	J19	39	P15	41
D15	40	J27	39	P16	41
I19	A 38	J28	39	P17	41
I21	C 38	J29	39	P18	41
J9	39	J30	39	P19	41
J10	39	P12	A 41	P20	41
J15	39	P13	B 41		
J17	39	P14	41		

I19 (A), I20 (B), I21 (C)
INSTRUMENT ECU

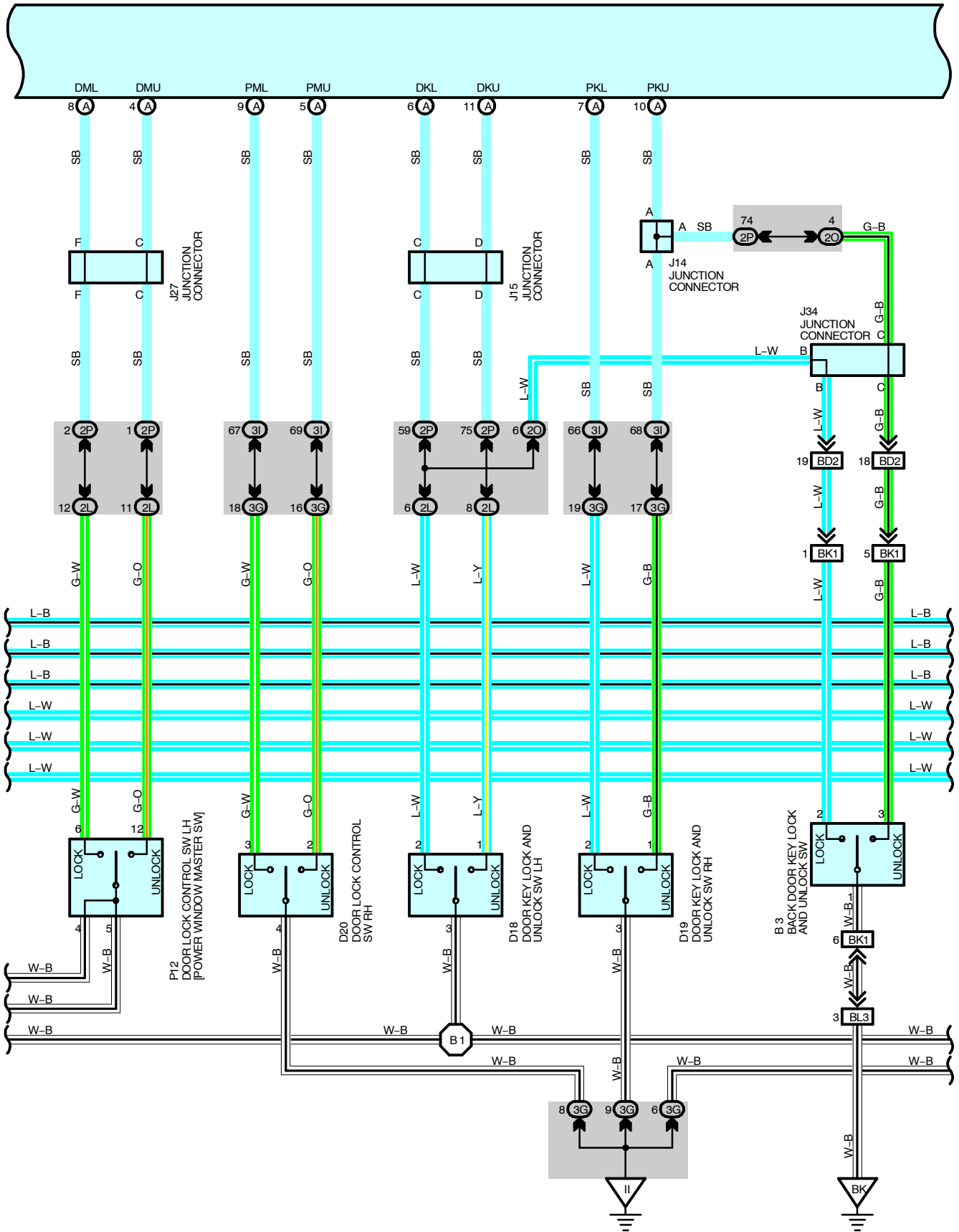

119 (A), 120 (B), 121 (C)
INSTRUMENT ECU

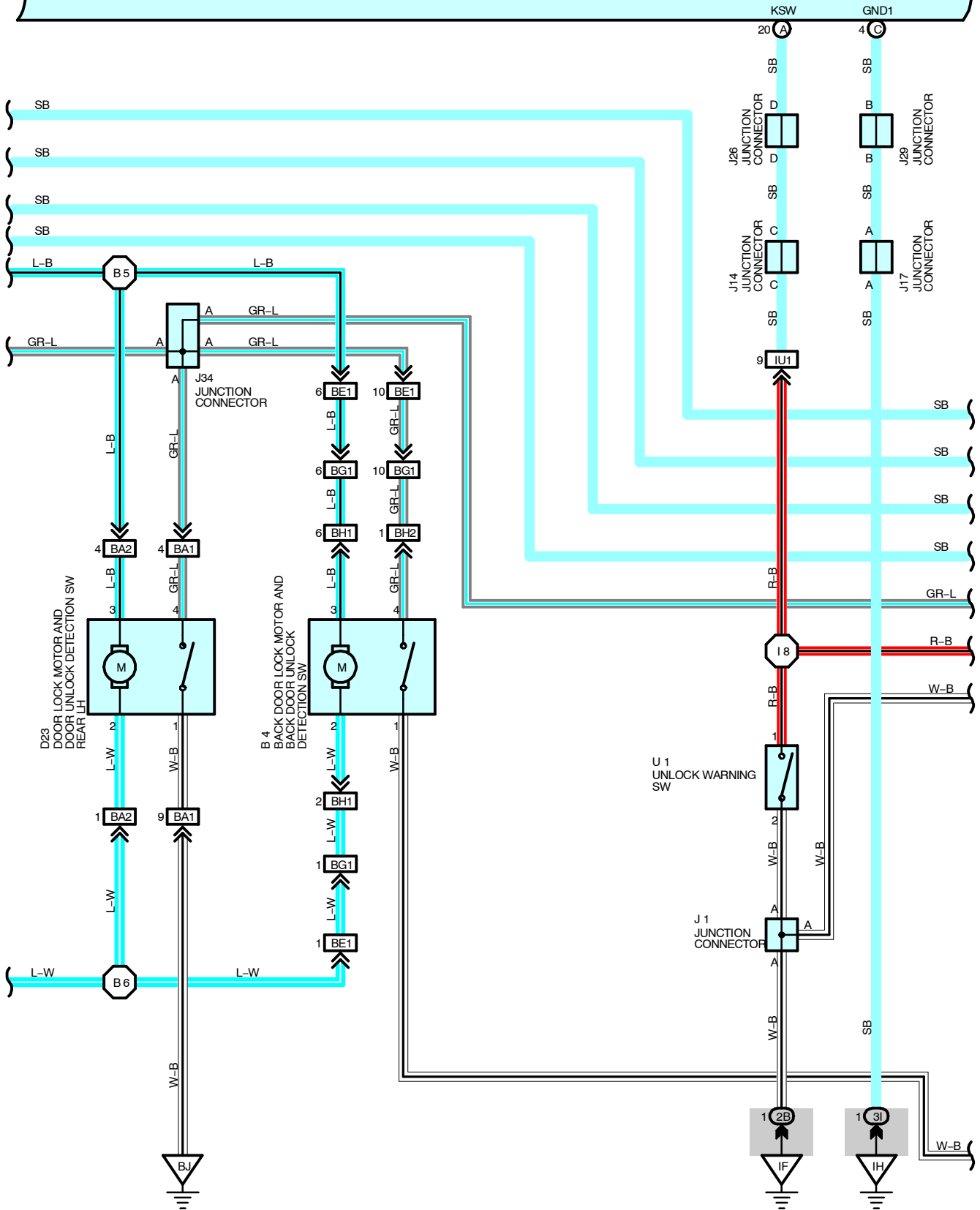

T 5 (A), T 6 (B)
THEFT DETERRENT ECU

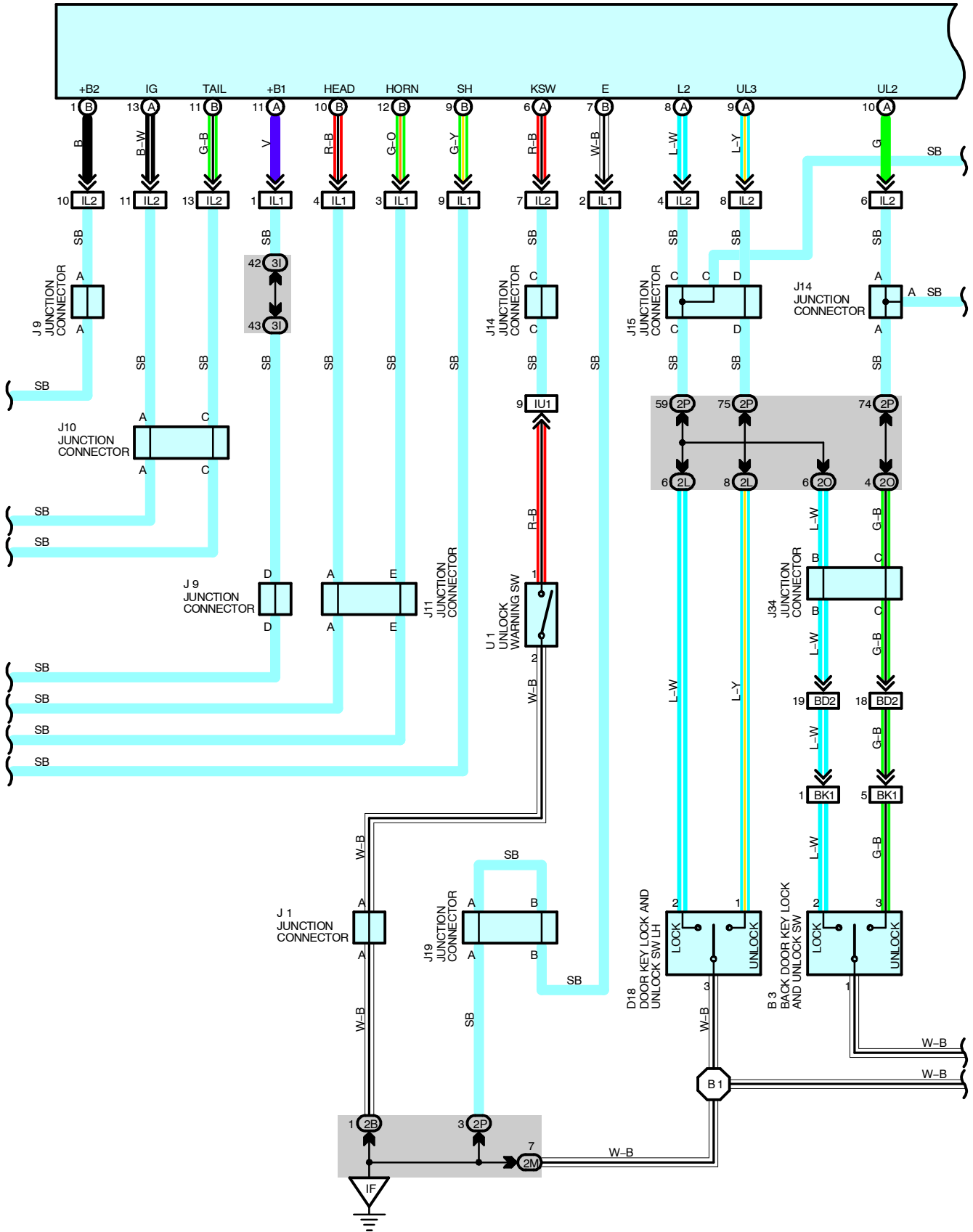

L3



P23

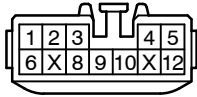

P24

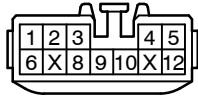

P25
ORANGE

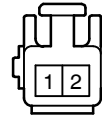

P26

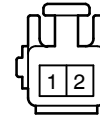

P27
BLUE

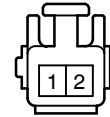

P28

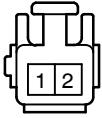

P29

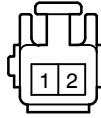

P30
ORANGE

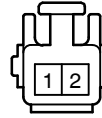

P31
BLUE

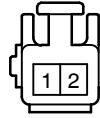

P32

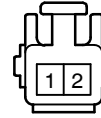

P33

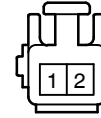

SERVICE HINTS

P6 POWER QUARTER WINDOW SW LH

4-GROUND : Approx. 12 volts with ignition SW at **ON** or **ST** position

6-GROUND : Always continuity

P7 POWER QUARTER WINDOW SW RH

4-GROUND : Approx. 12 volts with ignition SW at **ON** or **ST** position

6-GROUND : Always continuity

○ : PARTS LOCATION

Code	See Page	Code	See Page	Code	See Page
J14	39	P6	39	P11	41
J19	39	P7	39		
J41	40	P10	41		

○ : JUNCTION BLOCK AND WIRE HARNESS CONNECTOR

Code	See Page	Junction Block and Wire Harness (Connector Location)
2N	24	Floor Wire and Cowl Side J/B LH (Left Kick Panel)
2P	26	Instrument Panel Integration Wire and Cowl Side J/B LH (Left Kick Panel)
3F	30	Floor No.2 Wire and Cowl Side J/B RH (Right Kick Panel)
3I	30	Instrument Panel Integration Wire and Cowl Side J/B RH (Right Kick Panel)

□ : CONNECTOR JOINING WIRE HARNESS AND WIRE HARNESS

Code	See Page	Joining Wire Harness and Wire Harness (Connector Location)
IF1	46	Instrument Panel Integration Wire and Instrument Panel Wire (Left Side of Instrument Panel)
IF2		
BE2	54	Luggage Room Wire and Floor Wire (Left Rear Side Quarter Panel)
BI1	56	Roof No.2 Wire and Floor No.2 Wire (Right Side Rear Quarter Panel)

▽ : GROUND POINTS

Code	See Page	Ground Points Location
IF	46	Set Bolt of Cowl Side J/B LH

○ : SPLICE POINTS

Code	See Page	Wire Harness with Splice Points	Code	See Page	Wire Harness with Splice Points
I3	48	Instrument Panel Wire			

J14

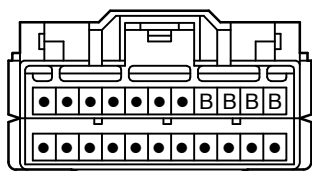

(Hint : See Page 7)

J19
GRAY

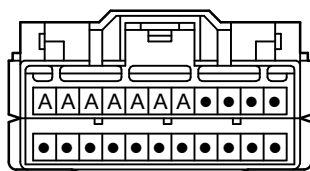

(Hint : See Page 7)

J41
BLUE

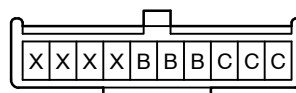

(Hint : See Page 7)

P6
BLACK

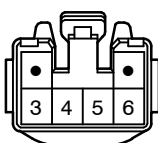

P7
BLACK

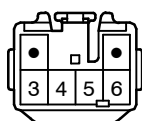

P10



P11

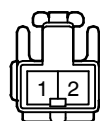

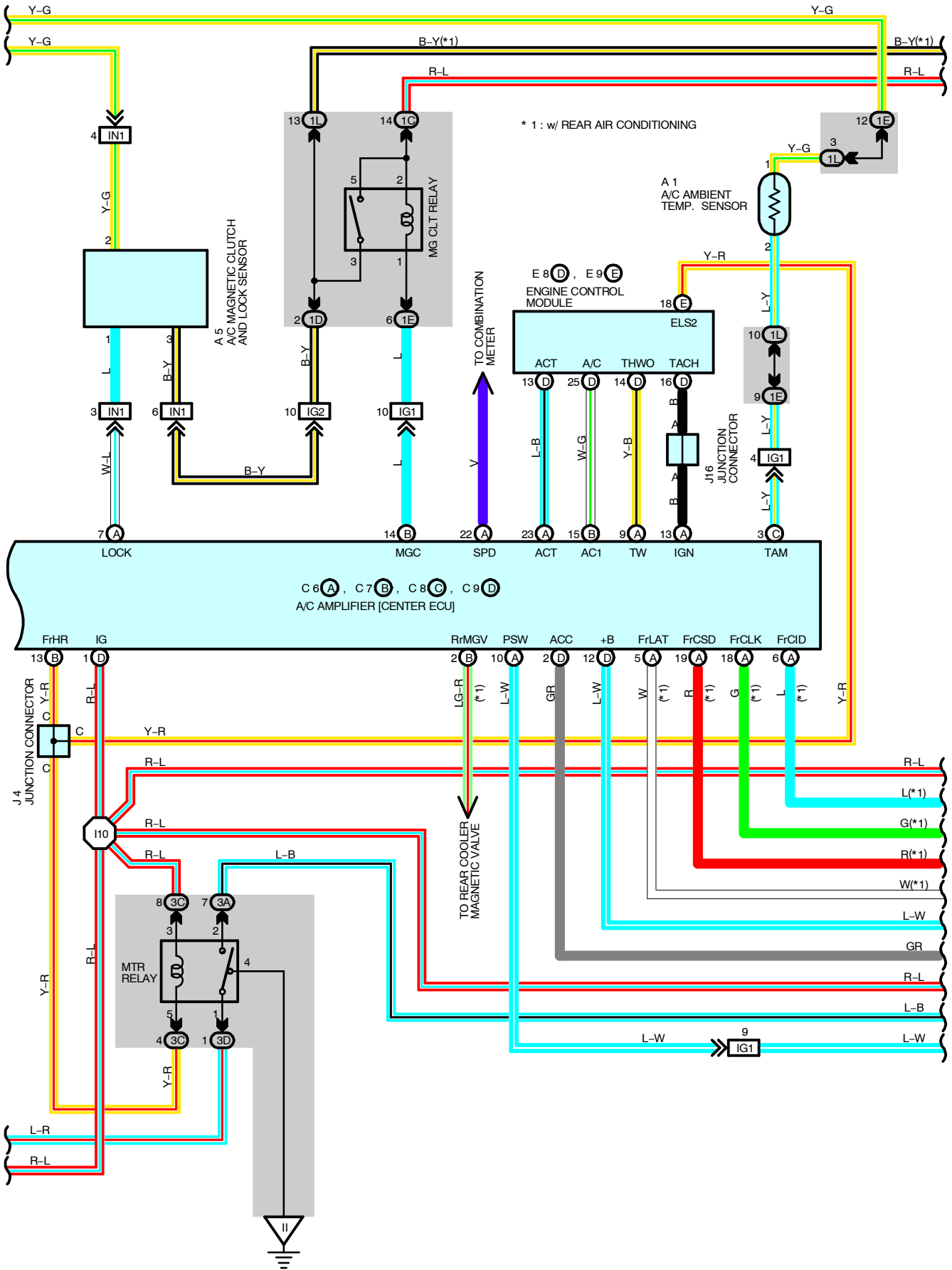

SYSTEM OUTLINE

1. COOLER AND HEATER BLOWER OPERATION

* Manual operation

When the blower control SW in the rear A/C control SW is set to any blower speed, a signal is sent to the A/C amplifier (Rear). The A/C amplifier (Rear) controls the power transistor and operates the rear cooler blower motor and rear heater blower motor at the set speed.

* Auto operation

When the auto SW in the rear A/C control SW is operated, a signal is sent to the A/C amplifier (Rear). The A/C amplifier (Rear) controls the power transistor according to the signals from respective sensors, and operates the rear cooler blower motor and rear heater blower motor.

2. AIR MIX CONTROL SERVO MOTOR CONTROL

When the temperature control lever in the rear A/C control SW is operated, a signal is sent to the A/C amplifier (Rear). The A/C amplifier (Rear) controls the rear air mix control servo motor to operate the damper until it reaches the temperature set by the temperature control lever.

3. AIR CONDITIONING OPERATION

The cooler and heater operation can be switched by the mode select SW in the rear A/C control SW.

SERVICE HINTS

A32 A/C AMPLIFIER (REAR)

+B-GROUND : Always approx. 12 volts

IG1-GROUND : Approx. 12 volts with ignition SW at **ON** or **ST** position

GND-GROUND : Always continuity

○ : PARTS LOCATION

Code	See Page	Code	See Page	Code	See Page	
A32	A	40	J31	40	R17	41
A33	B	40	J38	40	R21	41
A34	C	40	J39	40	R22	41
C6	A	38	R8	41	R25	41
C7	B	38	R9	41	R26	41
C9	D	38	R14	41	R34	41
J1		39	R15	41		
J9		39	R16	41		

○ : JUNCTION BLOCK AND WIRE HARNESS CONNECTOR

Code	See Page	Junction Block and Wire Harness (Connector Location)
1C	21	Engine Room No.2 Wire and Engine Room J/B (Engine Compartment Left)
2B	24	Dash Wire and Cowl Side J/B LH (Left Kick Panel)
2D		
2E	24	Engine Room No.2 Wire and Cowl Side J/B LH (Left Kick Panel)
2F		
2N	24	Floor Wire and Cowl Side J/B LH (Left Kick Panel)
2P	26	Instrument Panel Integration Wire and Cowl Side J/B LH (Left Kick Panel)
3E	30	Floor No.2 Wire and Cowl Side J/B RH (Right Kick Panel)
3I	30	Instrument Panel Integration Wire and Cowl Side J/B RH (Right Kick Panel)

□ : CONNECTOR JOINING WIRE HARNESS AND WIRE HARNESS

Code	See Page	Joining Wire Harness and Wire Harness (Connector Location)
IR1	50	Engine Room No.2 Wire and Floor No.2 Wire (Right Kick Panel)
IV2	52	Dash Wire and Floor No.2 Wire (Behind the Glove Box)
BD1	54	Floor No.3 Wire and Floor Wire (Left Rear Side Quarter Panel)
BJ1	56	Floor No.2 Wire and A/C Sub Wire (Right Side Rear Quarter Panel)
BL1	56	Floor No.2 Wire and Floor No.3 Wire (Right Side of Rear Floor Crossmember)
BL2		



: SPLICE POINTS

Code	See Page	Wire Harness with Splice Points	Code	See Page	Wire Harness with Splice Points
E2	44	Engine Room Main Wire	I18	48	Rear Console Box Wire
E5	44	Engine Room No.2 Wire	B1	56	Front Door LH Wire
E6	44	Engine Room Main Wire	B4	56	Floor Wire
E7	44	Engine Wire	B7	56	Roof Wire
E8	44	Transmission Wire	B9	56	Floor No.2 Wire
E9			B10		
E10	44	Engine Wire	B11	56	Floor Wire
E13	44	Engine Room No.2 Wire	B12	56	Frame Wire
F14			B14	56	Floor No.2 Wire
I3	48	Instrument Panel Wire	B15	56	Back Door Upper Wire
I6	48	Dash Wire	B16	56	Floor No.3 Wire
I9	48	Column Wire	B17	56	Back Door Lower Wire
I10	48	Dash Wire	B21	58	Front Seat LH Wire
I12	48	Console Box Wire	B22	58	Front Seat RH Wire
I15	48	Dash Wire			

J1

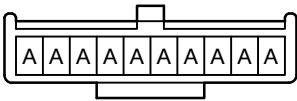

(Hint : See Page 7)

J2

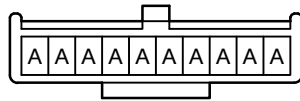

(Hint : See Page 7)

J17

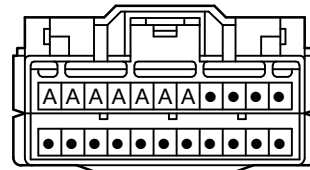

(Hint : See Page 7)

J19
GRAY

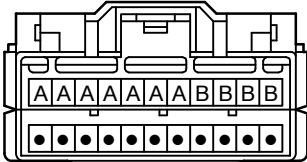

(Hint : See Page 7)

J22
RED

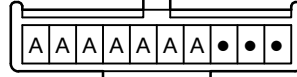

(Hint : See Page 7)

J26
BLUE

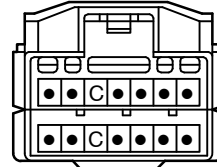

(Hint : See Page 7)

J29

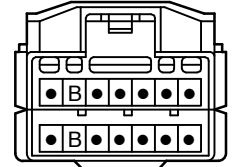

(Hint : See Page 7)

J30
BLUE

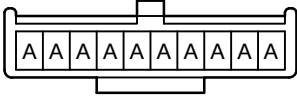

(Hint : See Page 7)

J32

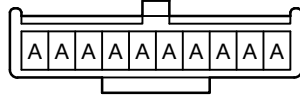

(Hint : See Page 7)

J39

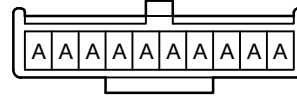

(Hint : See Page 7)

4 LAND CRUISER (Cont' d)

Headlight

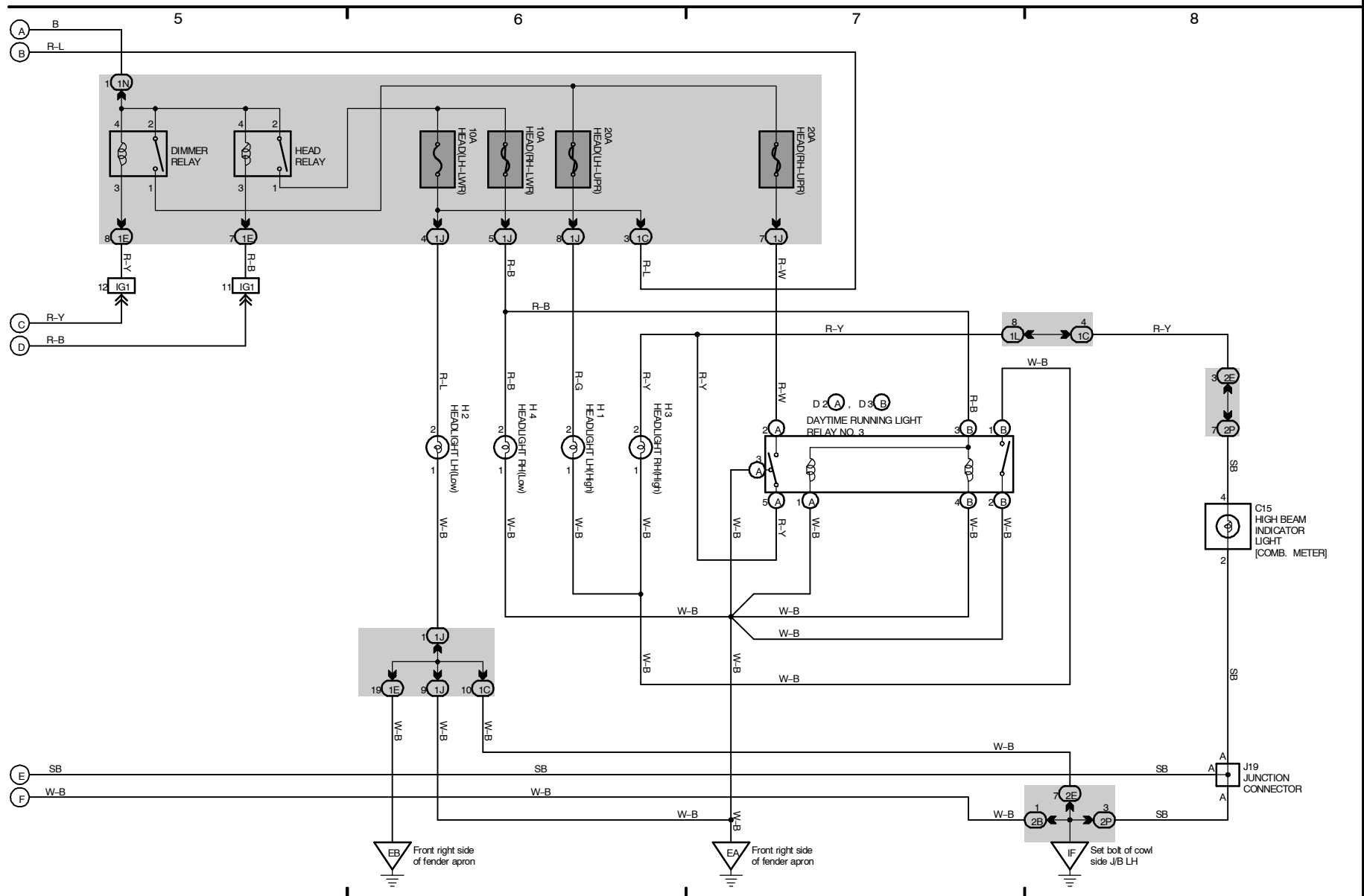

Door Lock Control

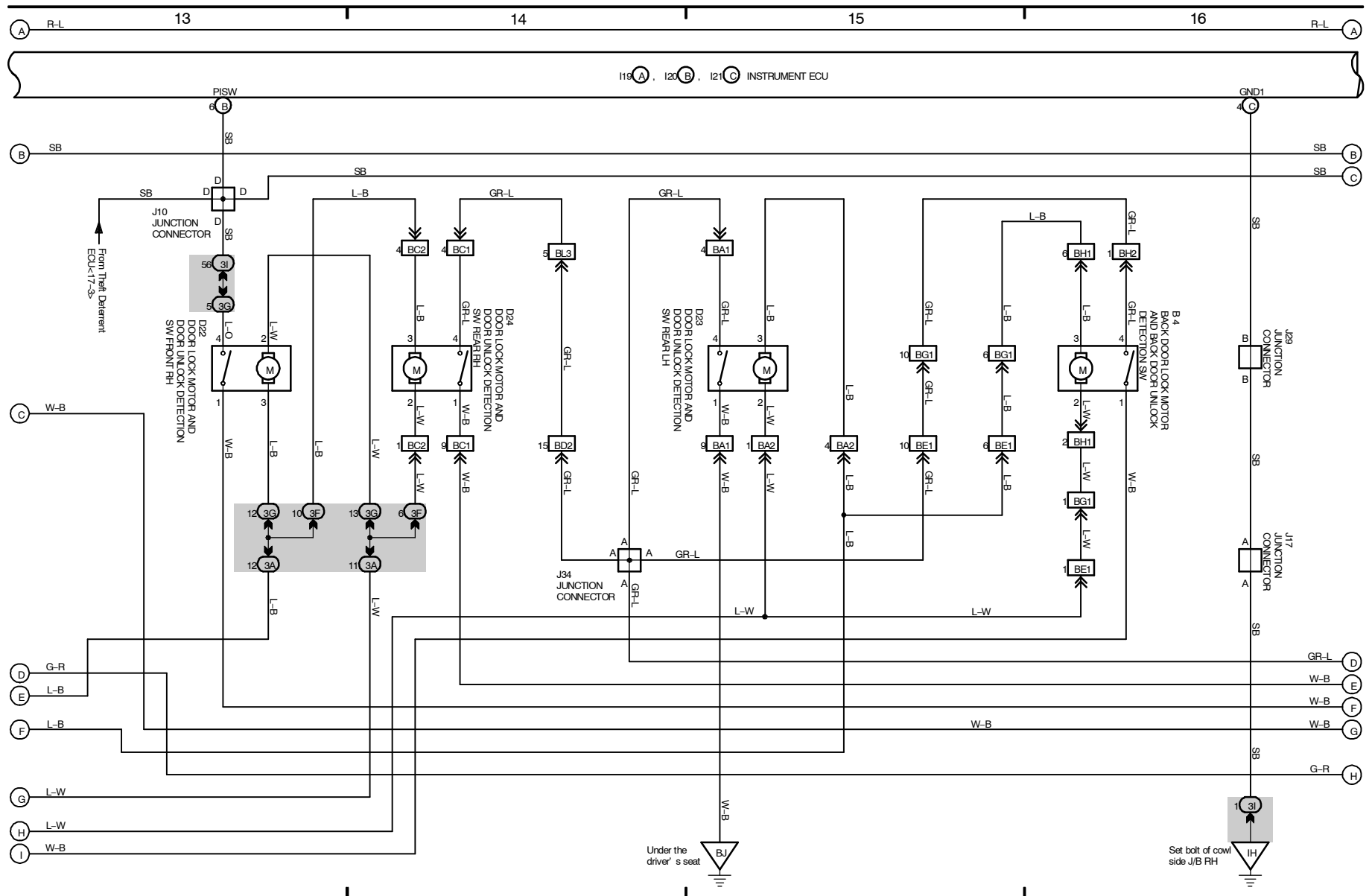

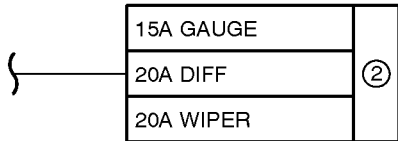
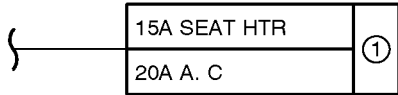
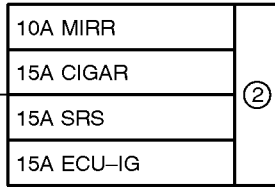
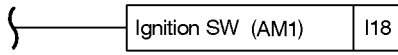
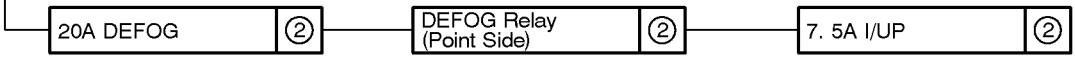
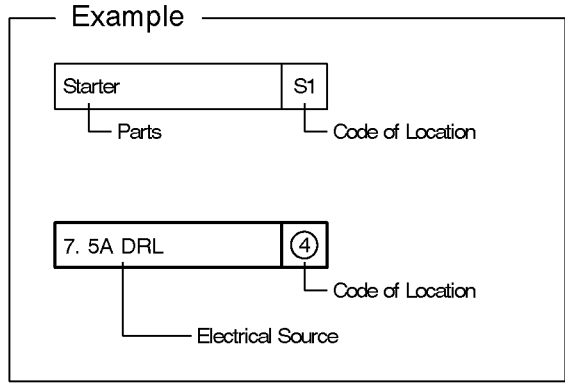
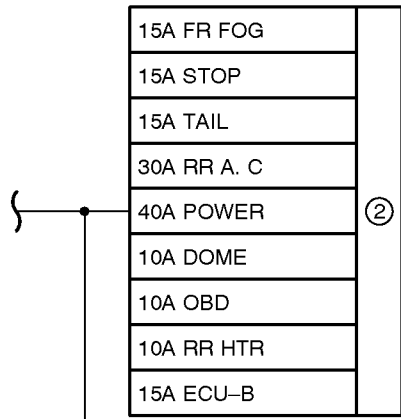

③ : Fusible Link Block (F 6 on See Page 34)

CLICK HERE TO **DOWNLOAD** THE COMPLETE MANUAL

- Thank you very much for reading the preview of the manual.
- You can download the complete manual from: www.heydownloads.com by clicking the link below



- Please note: If there is no response to CLICKING the link, please download this PDF first and then click on it.

CLICK HERE TO **DOWNLOAD** THE COMPLETE MANUAL