

# PACCAR SERVICE MANUAL

Section	Electrical System Service Manual
Number	PM819003/KM815056
Date	09/16/2011

## 2010 Multiplexed Electrical System Service Manual — CECU3 with Chassis Node

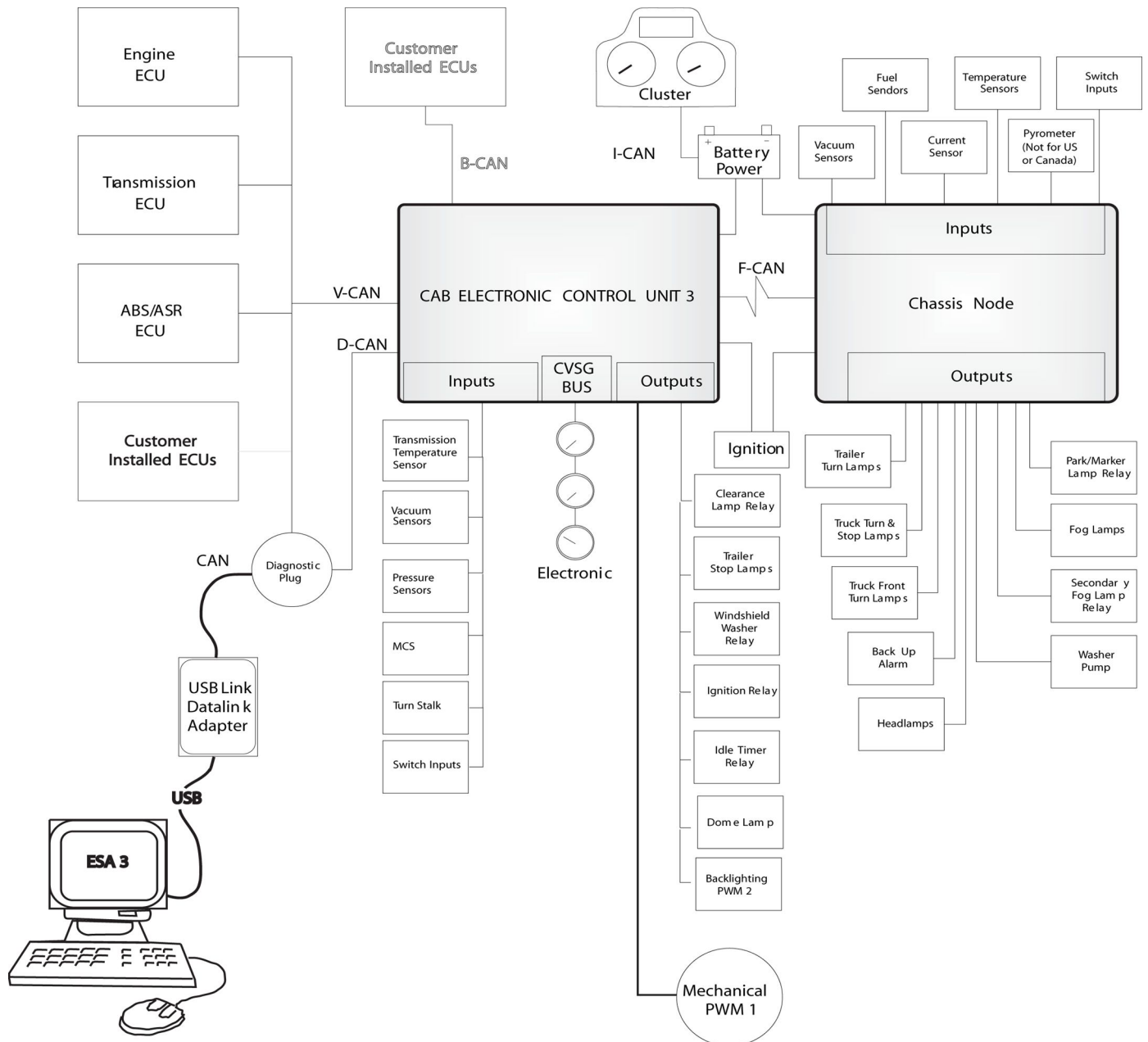

CLICK HERE TO **DOWNLOAD** THE COMPLETE MANUAL

- Thank you very much for reading the preview of the manual.
- You can download the complete manual from: [www.heydownloads.com](http://www.heydownloads.com) by clicking the link below



- Please note: If there is no response to CLICKING the link, please download this PDF first and then click on it.

CLICK HERE TO **DOWNLOAD** THE COMPLETE MANUAL

---

## **3 Exploded View**

**Control Unit Location . . . . . 3 - 2**

### Monitoring Data Bus

With ESA 3 the user is now able to monitor the vehicle data bus. Select the data bus group to be monitored. A table will open that shows all Control Units communicating on the bus. If a control unit stops communicating during the monitoring session, the status will change from Active to Inactive. If needed, the user also has the capability to record messages on the data bus to be sent to your service manager for further analysis.

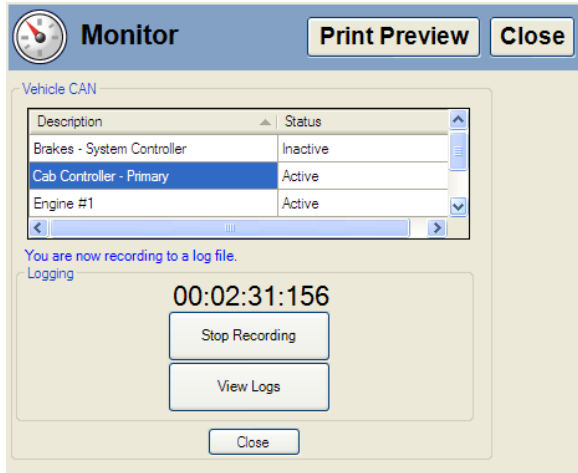

### Simulate - New Features

As with the monitor screen, to allow more viewing area when simulating components, there are auto-hide pin icons for reducing some of the sub-windows. When selected to auto-hide, the sub-window reduces to a tab on the left side of the screen. Simply place the cursor over the tab to bring the sub-window back up for further selection.

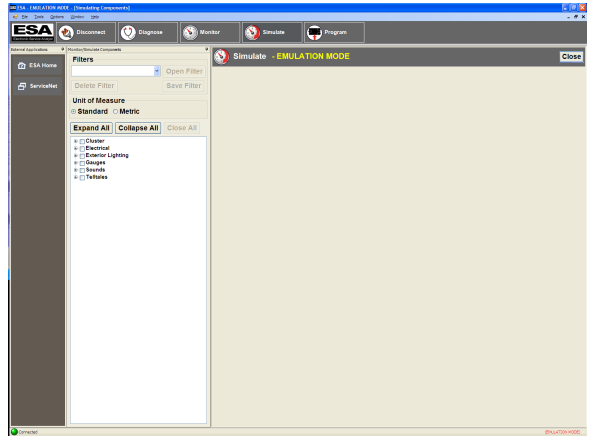

To make it easier to navigate to desired features, similar components have been grouped into a menu tree structure.

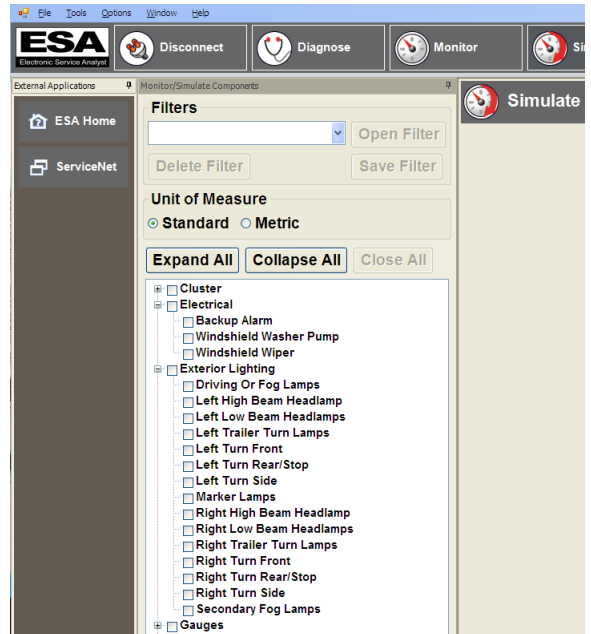

**CECU Comparison Chart - (Pinout)**

Conn	Pin Number	Circuit Function
A	1	CVSG power
	2	Power - battery
	3	Cab dome lamp
	4	Menu control switch power
	5	Ground
	6	Menu control switch ground
	7	Dash/panel illumination
	8	Auxiliary backlighting
	9	Power - battery
B	1	Menu control switch encode A
	2	Menu control switch encode B
	3	Menu control switch enter
	4	Courtesy lights - right door jamb switch
	5	Ignition input (Start)
	6	Dome lamp input
	7	Seat belt telltale
	8	Cruise set
	9	Cruise resume
	10	Back-up alarm mute
	11	Retarder select 1
	12	Retarder select 2
	13	Clutch switch
	14	Headlamps active
	15	PTO set
16	PTO resume	
17	Engine fan override	
18	Regen enable	
19	Inhibit regen	
20	ABS off road	
21	Marker lamp (Tractor)	
22	LVD input	
23	Transfer Case Engaged	
24	Spare digital input	

Conn	Pin Number	Circuit Function
C	1	Power supply +5V sensors
	2	Analog return
	3	PTO oil temp
	3	Spare analog input
	4	K-line
	5	Dimmer input
	6	Air pressure transducer - primary
	7	Air pressure transducer - secondary
	8	Air pressure transducer - application
	9	Spare analog input
	10	Air filter restriction
	11	Spare analog input
	12	Spare analog input
	13	Spare analog input
	14	CVSG data
	15	CVSG return
	16	Outside air temperature
	17	Spare analog input
	18	Spare analog input
	19	Spare analog input
	20	Spare analog input
	21	Transmission oil temperature - main
	22	Spare analog input
	23	Pyrometer
	24	Brakesaver oil temperature
	25	Analog return
	26	Spare analog input
	27	Remote throttle signal
	28	Spare analog input
	29	Spare analog input
	30	Spare analog input
	31	Wiper resistor ladder
	32	Turn signal resistor ladder
	33	LVD battery voltage
	34	Spare digital input
	35	C-CAN ground
	36	Not used
	37	C-CAN high
	38	C-CAN low
	39	Trailer stop lamp relay
	40	D-CAN high
	41	D-CAN low
	42	D-CAN ground
	43	B-CAN high
	44	B-CAN low
	45	B-CAN ground
	46	Marker flash
	47	Windshield washer pump
	48	DRL interrupt
	49	Marker lamp (Trailer)
	50	Fuel Level Sender Select
	51	Headlamp flash
52	Headlamp high/low	

CECU Parameter Part Number	Parameter Description	Min. Value	Max. Value	Explanation
Q30-1015-026	Axle Temperature Center/Steer Gauge Installed	0	1	Parameter controls the functionality (output on CVSG bus and DTC's) of the center axle temperature gauge. Value 0/Disabled means Axle Temperature Center/Steer Gauge is not installed. Value 1/Enabled means Axle Temperature Center/Steer Gauge is installed.
Q30-1015-027	Brake Applied Pressure Gauge Installed	0	1	Parameter controls the functionality (output on CVSG bus and DTC's) of the brake application pressure gauge. Value 0/Disabled means Brake Applied Pressure Gauge is not installed. Value 1/Enabled means Brake Applied Pressure Gauge is installed.
Q30-1015-028	Brakesaver Oil Temperature Gauge Installed	0	1	Parameter controls the functionality (output on CVSG bus and DTC's) of the brakesaver oil temperature gauge. Value 0/Disabled means Brakesaver Oil Temperature Gauge is not installed. Value 1/Enabled means Brakesaver Oil Temperature Gauge is installed.
Q30-1015-029	Engine Coolant Temperature Gauge Installed	0	1	Parameter controls the functionality (output on CVSG bus and DTC's) of the engine coolant temperature gauge. Value 0/Disabled means Engine Coolant Temperature Gauge is not installed. Value 1/Enabled means Engine Coolant Temperature Gauge is installed.
Q30-1015-030	Engine Manifold Pressure (Turbo Boost) Gauge Installed	0	1	Parameter controls the functionality (output on CVSG bus and DTC's) of the manifold pressure gauge. Value 0/Disabled means Manifold Pressure Gauge is not installed. Value 1/Enabled means Manifold Pressure Gauge is installed.
Q30-1015-031	Engine Oil Pressure Gauge Installed	0	1	Parameter controls the functionality (output on CVSG bus and DTC's) of the engine oil pressure gauge. Value 0/Disabled means Engine Oil Pressure Gauge is not installed. Value 1/Enabled means Engine Oil Pressure Gauge is installed.
Q30-1015-032	Engine Oil Temperature Gauge Installed	0	1	Parameter controls the functionality (output on CVSG bus and DTC's) of the engine oil temperature gauge. Value 0/Disabled means Engine Oil Temperature Gauge is not installed. Value 1/Enabled means Engine Oil Temperature Gauge is installed.
Q30-1015-033	Exhaust Temperature Gauge (Pyrometer) Installed	0	1	Parameter controls the functionality (output on CVSG bus and DTC's) of the exhaust temperature gauge. Value 0/Disabled means Exhaust Temperature Gauge is not installed. Value 1/Enabled means Exhaust Temperature Gauge is installed.
Q30-1015-034	Fuel Delivery Pressure Gauge Installed	0	1	Value 0/Disabled means Fuel Delivery Pressure Gauge is not installed. Value 1/Enabled means Fuel Delivery Pressure Gauge is installed.
Q30-1015-035	Fuel Filter Restriction Gauge Installed	0	1	Parameter controls the functionality (output on CVSG bus and DTC's) of the fuel restriction gauge. Value 0/Disabled means Fuel Filter Restriction Gauge is not installed. Value 1/Enabled means Fuel Filter Restriction Gauge is installed.
Q30-1015-036	General Oil Temperature Gauge Installed	0	1	Parameter controls the functionality (output on CVSG bus and DTC's) of the general oil temperature gauge. Value 0/Disabled means General Oil Temperature Gauge is not installed. Value 1/Enabled means General Oil Temperature Gauge is installed.
Q30-1015-037	Primary Air Pressure Gauge Installed	0	1	Parameter controls the functionality (output on CVSG bus and DTC's) of the primary air pressure gauge. Value 0/Disabled means Primary Air Pressure Gauge is not installed. Value 1/Enabled means Primary Air Pressure Gauge is installed.

CECU Parameter Part Number	Parameter Description	Min. Value	Max. Value	Explanation
Q30-1015-116	Gateway Engine LFE message	0	64	Parameter controls the settings for this individual message. Add the numbers together for multiple destinations. Value 0/OFF means this PGN will not be transmitted on any destination channels Value 1/BCAN means this PGN will be transmitted on BCAN Value 2/CCAN means this PGN will be transmitted on CCAN Value 4/DCAN means this PGN will be transmitted on DCAN Value 8/FCAN means this PGN will be transmitted on FCAN Value 16/ICAN means this PGN will be transmitted on ICAN Value 32/VCAN means this PGN will be transmitted on VCAN
Q30-1015-117	Gateway Transmission DM1 message	0	64	Parameter controls the settings for this individual message. Add the numbers together for multiple destinations. Value 0/OFF means this PGN will not be transmitted on any destination channels Value 1/BCAN means this PGN will be transmitted on BCAN Value 2/CCAN means this PGN will be transmitted on CCAN Value 4/DCAN means this PGN will be transmitted on DCAN Value 8/FCAN means this PGN will be transmitted on FCAN Value 16/ICAN means this PGN will be transmitted on ICAN Value 32/VCAN means this PGN will be transmitted on VCAN
Q30-1015-118	Gateway Transmission ETC1 message	0	64	Parameter controls the settings for this individual message. Add the numbers together for multiple destinations. Value 0/OFF means this PGN will not be transmitted on any destination channels Value 1/BCAN means this PGN will be transmitted on BCAN Value 2/CCAN means this PGN will be transmitted on CCAN Value 4/DCAN means this PGN will be transmitted on DCAN Value 8/FCAN means this PGN will be transmitted on FCAN Value 16/ICAN means this PGN will be transmitted on ICAN Value 32/VCAN means this PGN will be transmitted on VCAN
Q30-1015-119	Gateway Transmission ETC2 message	0	64	Parameter controls the settings for this individual message. Add the numbers together for multiple destinations. Value 0/OFF means this PGN will not be transmitted on any destination channels Value 1/BCAN means this PGN will be transmitted on BCAN Value 2/CCAN means this PGN will be transmitted on CCAN Value 4/DCAN means this PGN will be transmitted on DCAN Value 8/FCAN means this PGN will be transmitted on FCAN Value 16/ICAN means this PGN will be transmitted on ICAN Value 32/VCAN means this PGN will be transmitted on VCAN

## CECU Architecture

The software programming of the control unit can be grouped into three main types:

- Run Time (RT) - which acts as the operating system where all communication takes place.
- Programmable Logic Controller (PLC) Code - manufacturer specific programmed code and software that is developed, accessible and editable.
- Vendor Module - blocks of code that are developed for specific manufacturers to allow other features to be implemented more efficiently.

To better understand how Electronic Service Analyst (ESA) functions and why there are current

limitations on some of the multiplexed features, by explaining what ESA can see. Currently ESA can look at all information that is communicated between the RT and PLC Code portions of the programming. Any signals, be they inputs, outputs, or dataline signals, sent between the RT and PLC Code are visible to ESA. These are the signals that may be monitored and simulated using ESA.

Limitations with the ESA program are found in the communications that go to the pre-developed Vendor Modules. Currently this information is not available for ESA to look at. That is why some features that have Vendor Module programming, such as the odometer and the message display, are not available to monitor and/or simulate through ESA.

CECU3 (P30-1009-XXX) Communication Diagram

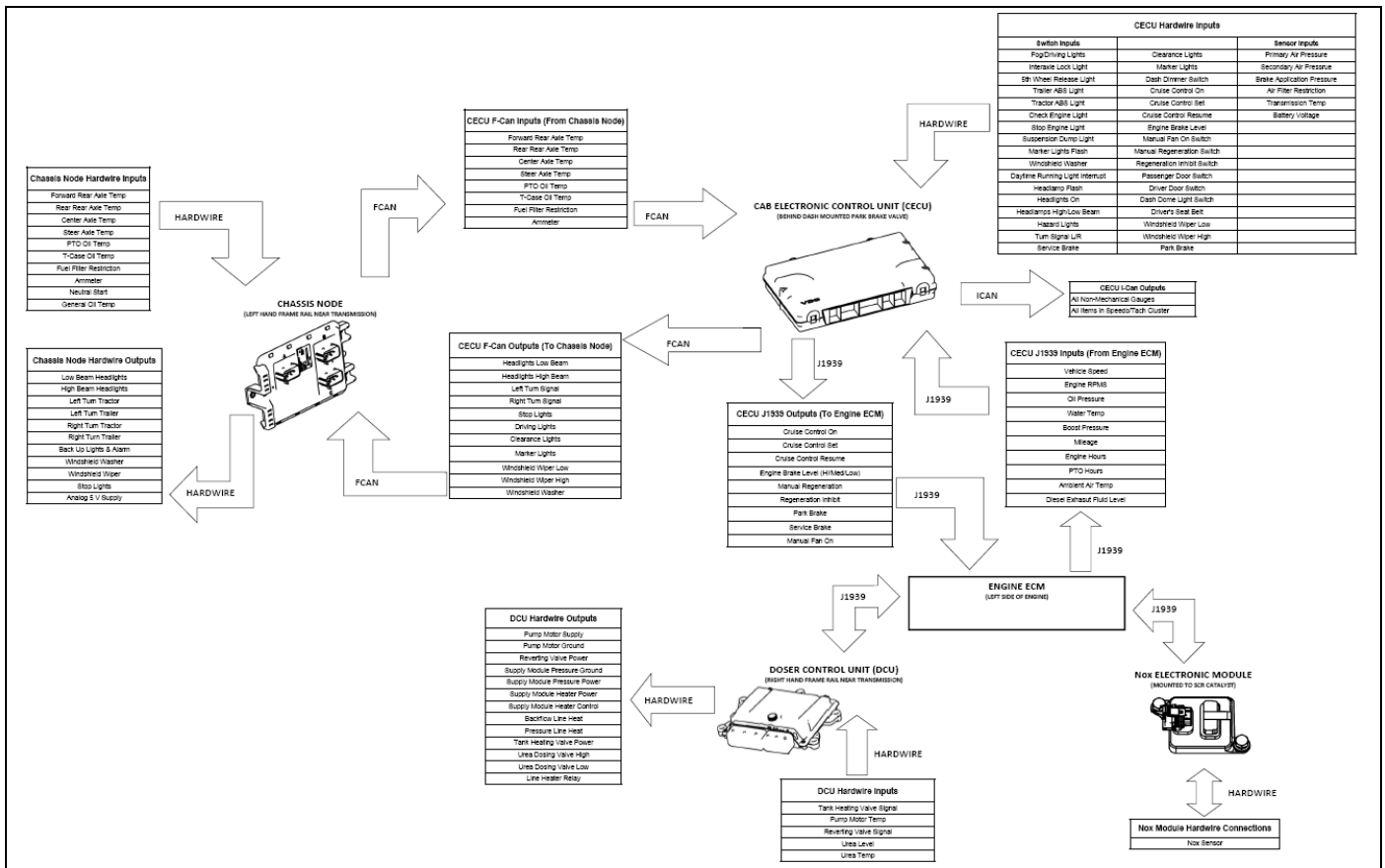

## Instruments and Controls Operation

Before attempting to repair any instrumentation problems, the technician should have a complete understanding of how the instruments and controls operate.

**Air Filter Restriction Pressure** - The Air Filter Restriction Pressure gauge indicates the condition of the engine air cleaner and is measured by inches of water (H<sub>2</sub>O). A clean filter should register 7 in. H<sub>2</sub>O (may vary with system design) and a filter whose life is over registers approximately 25 in. H<sub>2</sub>O.

**Air Starter Pressure** - The Air Starter Pressure Gauge indicates the amount of air pressure in the air start reservoir.

**Ammeter** - The Ammeter monitors the vehicle's electrical system and makes sure the system is in balance and operating normally. If not, it may be drawing power from the alternator (positive reading) or from the batteries (negative reading). Under normal conditions the ammeter will read nearly "zero."

**Axle, Drive Oil Temperature** - The Drive Axle Oil Temperature gauges (front, rear, and center) indicate the temperature of the lubricant in the vehicle's axles.

**Axle, Pusher Air Pressure, #1, #2, #3** - The Pusher Axle Air Pressure gauges indicate the air pressure in each of the pusher axles suspension air bags.

**Axle, Tag Air Pressure** - The Tag Axle Air Pressure gauge indicates the amount of air pressure in the tag axle suspension air bags.

**Brake, Application Air Pressure** - The Brake Application Air Pressure gauge indicates how much air pressure is being applied from the foot brake valve or trailer brake hand valve to the air brakes.

**BrakeSaver Application Air Pressure (Export vehicles only)** - The BrakeSaver Application Air Pressure gauge indicates the amount of air pressure applied to the BrakeSaver hand control valve.

**BrakeSaver Oil Temperature (Export vehicles only)** - The BrakeSaver Oil Temperature gauge

indicates the temperature in the BrakeSaver. If the oil temperature exceeds the maximum limits, a red warning lamp in the gauge turns on.

**Engine Coolant Temperature** - The Engine Coolant Temperature gauge indicates the temperature of the engine coolant. If the coolant temperature exceeds the maximum limits, a red warning lamp in the gauge illuminates and an audible warning sounds. If the coolant temperature continues to rise, the Check Engine and/or Stop Engine lights illuminate. Under normal operating conditions the water temperature gauge should register between 165 and 205°F (74 and 90°C). Under certain conditions, somewhat higher temperatures may be acceptable. The maximum allowable temperature is 220°F (104°C) with the cooling system pressurized, except for certain engines.

**Engine, Oil Pressure** - If the oil pressure drops below the minimum pressure a red warning light in the gauge illuminates, the Stop Engine light illuminates and an audible alarm tone sounds.

**Engine Oil Temperature** - The Engine Oil Temperature gauge indicates the engine oil temperature. If the oil temperature exceeds the maximum limits, a red warning light in the gauge illuminates.

**Engine Pyrometer (Export vehicles only)** - The Engine Pyrometer gauge indicates engine exhaust gas temperature. Since it responds almost immediately to changes in exhaust gas temperature, the pyrometer is an excellent indicator of engine output. Monitor it in conjunction with the tachometer and manifold pressure gauge.

**Fuel Filter Restriction Pressure** - This gauge tells you the condition of the fuel filter by indicating the restriction from the fuel filter to the fuel pump. The restriction is measured by inches of mercury (in-Hg).

**Fuel Level, Primary/Secondary (if equipped)** - The Primary Fuel gauge and Secondary Fuel gauge (if equipped) indicate the approximate amount of fuel in each fuel tank. In addition to indicating empty and full, the gauge(s) also indicate the fuel level in graduated increments. When the fuel level for each tank is below 1/4 full, a red warning light in the gauge illuminates.

## DIAGNOSTIC TROUBLE CODES

### Introduction

ESA is a PC-based diagnostic tool that detects fault codes and helps troubleshoot the new multiplexed electrical system. ESA communicates over a data-link adapter (DLA) to the vehicle CECU.

ESA will:

- Verify instrumentation functionality
- Read fault codes from components
- Diagnose the problem using information on ServiceNet

The following chart provides a listing of possible CECU diagnostic trouble codes (DTCs) and links to their corresponding troubleshooting procedures.

DTC	CECU3/Chassis Node	Item / System	Description	Detailed Description
1603	Chassis Node	Fuel Filter Restriction	Open in fuel filter restriction circuit	This DTC will be recorded when the control unit sees an open or short to ground at the fuel filter restriction sensor input. Some possible causes for this are a broken wire, corroded or disconnected connector, or sensor failure. The wiring for this sensor runs from the chassis node through the chassis harness and sender extension harness to the sensor on the fuel filter.
1604	Chassis Node	Fuel Filter Restriction	Short in fuel filter restriction circuit	This DTC will be recorded when the control unit sees a short to +5V at the fuel filter restriction sensor input. Some possible causes for this are a pinched wire, water in a connector, or sensor failure. The wiring for this sensor runs from the chassis node through the chassis harness and sender extension harness to the sensor on the fuel filter.
7703	Chassis Node	Rear Drive Oil Temp	Open in rear drive axle oil temp circuit	This DTC will be recorded when the control unit sees an open at the rear drive axle oil temperature sensor input. Some possible causes for this are a broken wire, corroded or disconnected connector, or sensor failure. The wiring for this sensor runs from the chassis node through the chassis harness and rear axle harness to the sensor on the rear drive axle.
7704	Chassis Node	Rear Drive Oil Temp	Short in rear drive axle oil temp circuit	This DTC will be recorded when the control unit sees a short to ground at the rear drive axle oil temperature sensor input. Some possible causes for this are a pinched wire, water in a connector, or sensor failure. The wiring for this sensor runs from the chassis node through the chassis harness and rear axle harness to the sensor on the rear drive axle.
7803	Chassis Node	Center/Steer axle Oil Temp	Open in Center/Steer axle oil temp circuit	This DTC will be recorded when the control unit sees an open at the center drive axle oil temperature sensor input. Some possible causes for this are a broken wire, corroded or disconnected connector, or sensor failure. The wiring for this sensor runs from the chassis node through the chassis harness and rear axle harness to the sensor on the center drive axle.

CLICK HERE TO **DOWNLOAD** THE COMPLETE MANUAL

- Thank you very much for reading the preview of the manual.
- You can download the complete manual from: [www.heydownloads.com](http://www.heydownloads.com) by clicking the link below



- Please note: If there is no response to CLICKING the link, please download this PDF first and then click on it.

CLICK HERE TO **DOWNLOAD** THE COMPLETE MANUAL

DTC	CECU3/Chassis Node	Item / System	Description	Detailed Description
2350xx	Chassis Node	Exterior Lighting - Low Beam	Low Beam Output Fault	This set of DTCs (xx = anything) will be recorded when there is a problem with one of the Low Beam circuits. This could be caused by failed bulbs, wiring harness issues, or corroded connectors. Left low beam output from Pin 1 of the Chassis Node connector A. Right low beam output from Pin 19 of the Chassis Node connector A.
2368xx	Chassis Node	Exterior Lighting - Left Front Turn	Left Front Turn Fault	This set of DTCs (xx = anything) will be recorded when there is a problem with one of the Left Front Turn circuit. This could be caused by failed bulbs, wiring harness issues, or corroded connectors. Left front turn output from Pin 4 of the Chassis Node connector B.
2370xx	Chassis Node	Exterior Lighting - Right Front Turn	Right Front Turn Fault	This set of DTCs (xx = anything) will be recorded when there is a problem with one of the Right Front Turn circuit. This could be caused by failed bulbs, wiring harness issues, or corroded connectors. Right front turn output from Pin 7 of the Chassis Node connector B.
2372xx	Chassis Node	Exterior Lighting - Tractor/Truck Left Rear Turn/Stop	Tractor/Truck Left Rear Turn/Stop Fault	This set of DTCs (xx = anything) will be recorded when there is a problem with one of the Left Rear Turn/Stop circuit. This could be caused by failed bulbs, wiring harness issues, or corroded connectors. Tractor/Truck left rear turn/stop output from Pin 13 of the Chassis Node connector B.
2374xx	Chassis Node	Exterior Lighting - Tractor/Truck Right Rear Turn/Stop	Tractor/Truck Right Rear Turn/Stop Fault	This set of DTCs (xx = anything) will be recorded when there is a problem with one of the Right Rear Turn/Stop circuit. This could be caused by failed bulbs, wiring harness issues, or corroded connectors. Tractor/Truck right rear turn/stop output from Pin 2 of the Chassis Node connector B.
2378xx	Chassis Node	Exterior Lighting - Marker Lamp	Marker Lamp Fault	This set of DTCs (xx = anything) will be recorded when there is a problem with one of the Marker Lamp circuit. This could be caused by failed bulbs, wiring harness issues, or corroded connectors. Marker lamp relay control output from Pin 10 of the Chassis Node connector A.
2382xx	CECU	Exterior Lighting - Clearance Lamp	Clearance Lamp Fault	This set of DTCs (xx = anything) will be recorded when there is a problem with one of the Clearance Lamp circuit. This could be caused by failed bulbs, wiring harness issues, or corroded connectors.
2388xx	Chassis Node	Exterior Lighting - Fog Lamp	Fog Lamp Fault	This set of DTCs (xx = anything) will be recorded when there is a problem with one of the Fog Lamp circuit. This could be caused by failed bulbs, wiring harness issues, or corroded connectors. Fog lamps output from Pin 15 of the Chassis Node connector B.

Step	Check	Result	Next Step																												
		<p><b>i</b> <b>NOTE</b></p> <p>Make sure that the system you are testing has some pressure to measure.</p>	<ol style="list-style-type: none"> <li>Connector Seal</li> <li>Pin A</li> <li>Pin B</li> <li>Place MultiMeter Probe On Pin C</li> </ol>																												
6	Select "Diagnose" to view primary air pressure gauge DTCs. Next, unplug the primary air pressure sensor connector at sensor. See <a href="#">CECU Pinout</a> for terminal details of the CECU electrical connections.	DTC <b>11703</b> – Open in primary air pressure circuit is displayed as "Active."	<ol style="list-style-type: none"> <li>Check resistance between Pin C and ground terminal.                             <ol style="list-style-type: none"> <li>If there is less than 5K ohms between Pin C and the ground terminal,                                     <ol style="list-style-type: none"> <li>Check wiring for short from sensor to CECU. If short found, repair and go to <b>Step 2</b>.</li> <li>Remove the 52 Pin CECU connector C and measure resistance between Pin 6 of the 52 Pin CECU connector C and ground terminal. If less than 5K ohms replace CECU and go to <b>Step 2</b>.</li> </ol> </li> <li>If there is more than 20K ohms between Pin C and ground terminal,                                     <ol style="list-style-type: none"> <li>Check wiring for open from sensor to CECU. If open found, repair and go to <b>Step 2</b>.</li> <li>Remove the "C" connector from the CECU and measure resistance between Pin 6 of the 52 Pin CECU connector C and ground terminal. If more than 20K ohms, replace CECU and go to <b>Step 2</b>.</li> </ol> </li> </ol> </li> </ol>																												
7	Select "Diagnose" to view primary air pressure gauge DTCs. Next, unplug the primary air pressure sensor connector at sensor. See <a href="#">CECU Pinout</a> for terminal details of the CECU electrical connections.	DTC <b>11704</b> - Short in primary air pressure circuit is displayed as "Active".	<ol style="list-style-type: none"> <li>If the fault is still "Active" after unplugging the sensor connector, you have confirmed there is a short. This sensor wire starts at pin 6 of the 52 Pin CECU connector C and ends at pin C on the sensor connector. There is a short between the sensor wire and a power source wire. Some typical power wires to inspect are listed below (you may need to verify any power source in the main cab harness):                             <table border="1" style="width: 100%; border-collapse: collapse;"> <thead> <tr> <th>Description</th> <th>CECU Pin</th> </tr> </thead> <tbody> <tr> <td>Power Supply Sensor +5V</td> <td>Connector C, Pin 1</td> </tr> <tr> <td>Dash Illumination 1</td> <td>Connector A, Pin 7</td> </tr> <tr> <td>CVSG Power</td> <td>Connector A, Pin 1</td> </tr> </tbody> </table> <p>Each power supply ends at the following connectors:</p> <table border="1" style="width: 100%; border-collapse: collapse;"> <thead> <tr> <th>Description</th> <th>Pin</th> </tr> </thead> <tbody> <tr> <td>CVSG gauge power</td> <td>4</td> </tr> <tr> <td>CVSG lighting</td> <td>2</td> </tr> <tr> <td>Primary air pressure transducer</td> <td>B</td> </tr> <tr> <td>Secondary air pressure</td> <td>B</td> </tr> <tr> <td>Application air pressure transducer</td> <td>B</td> </tr> <tr> <td>Air filter restriction</td> <td>C</td> </tr> <tr> <td>For future expansion</td> <td>A</td> </tr> <tr> <td>Through the Engine Harness Connector...</td> <td>28</td> </tr> <tr> <td>For the Ammeter sensor</td> <td>A</td> </tr> </tbody> </table> <p>Check for pinched or chaffed sensor and power wiring. Repair or replace wiring as necessary. <b>Go to Step 2.</b></p> </li> </ol>	Description	CECU Pin	Power Supply Sensor +5V	Connector C, Pin 1	Dash Illumination 1	Connector A, Pin 7	CVSG Power	Connector A, Pin 1	Description	Pin	CVSG gauge power	4	CVSG lighting	2	Primary air pressure transducer	B	Secondary air pressure	B	Application air pressure transducer	B	Air filter restriction	C	For future expansion	A	Through the Engine Harness Connector...	28	For the Ammeter sensor	A
Description	CECU Pin																														
Power Supply Sensor +5V	Connector C, Pin 1																														
Dash Illumination 1	Connector A, Pin 7																														
CVSG Power	Connector A, Pin 1																														
Description	Pin																														
CVSG gauge power	4																														
CVSG lighting	2																														
Primary air pressure transducer	B																														
Secondary air pressure	B																														
Application air pressure transducer	B																														
Air filter restriction	C																														
For future expansion	A																														
Through the Engine Harness Connector...	28																														
For the Ammeter sensor	A																														
		DTC <b>11704</b> - Short in primary air pressure circuit is now displayed as "Inactive."	<p>If DTC 11704 changes to "Inactive" after unplugging the sensor connector, you have confirmed the problem is a short to +5V in the sensor itself, not the wiring.</p> <ol style="list-style-type: none"> <li>Replace sensor. Go to <b>Step 2</b>.</li> </ol>																												

[Return to Table Of Contents](#)

Step	Check	Result	Next Step				
1	Turn ignition key ON. Start ESA, then select "Connect" to establish communication to the vehicle.		Go to <b>Step 2</b> .				
2	Select "Monitor." From the "Components" window, select "Air Filter RestrictionPressure." then select "Open."	Gauge graphic on screen displays reasonable reading.	Go to <b>Step 3</b> .				
		Gauge graphic on screen does not display reasonable reading.	Go to <b>Step 4</b> .				
3	Select "Simulate". Drag the "Value" bar until the pointer on the gauge image is approximately mid-scale. Observe vehicle gauge movement.	Vehicle gauge does not move. Go to <b>Step 3-1</b> .	Perform the following checks:				
		Vehicle gauge reading is in the same range as the ESA gauge image. Go to <b>Step 3-7</b> .	<table border="1"> <tr> <td data-bbox="792 569 833 604" style="text-align: center;"><b>i</b></td> <td data-bbox="1036 569 1117 604" style="text-align: center;"><b>NOTE</b></td> </tr> <tr> <td colspan="2" data-bbox="800 615 1507 747">Use the "Program" feature in ESA to make sure that the parameter for the inoperative gauge is enabled. An inoperative gauge may simply have its CECU parameter set to disabled.</td> </tr> </table>	<b>i</b>	<b>NOTE</b>	Use the "Program" feature in ESA to make sure that the parameter for the inoperative gauge is enabled. An inoperative gauge may simply have its CECU parameter set to disabled.	
			<b>i</b>	<b>NOTE</b>			
Use the "Program" feature in ESA to make sure that the parameter for the inoperative gauge is enabled. An inoperative gauge may simply have its CECU parameter set to disabled.							
<ol style="list-style-type: none"> <li>1. Check CVSG data link wiring: Observe Gauge position in the wiring daisy chain.                             <ol style="list-style-type: none"> <li>a. If gauge is mounted between two other functioning gauges CVSG data link wiring is OK. Go to <b>Step 3-5</b>.</li> <li>b. If gauge is last gauge in daisy chain or followed by other non-functional gauges, go to <b>Step 3-2</b>.</li> </ol> </li> <li>2. Check continuity between Pin 1 on gauge harness connector and Pin 14 of the 52 Pin CECU connector C.</li> <li>3. Check continuity between Pin 3 on gauge harness connector and Pin 15 of the 52 Pin CECU connector C.</li> <li>4. Repair daisy chain jumper harness as necessary.</li> <li>5. Once continuity on both wires exists, perform "Simulate" test again.                             <ol style="list-style-type: none"> <li>a. If gauge functions properly during "Simulate" test, repair is complete. <b>Return truck to service.</b></li> <li>b. If gauge does not function during "Simulate" test, install a known good gauge and perform "Simulate" test again.                                     <ol style="list-style-type: none"> <li>i. If gauge functions properly test is complete. Install new gauge permanently. Re-test and <b>return truck to service</b>.</li> <li>ii. If gauge does not function during "Simulate" test, install Test CECU and perform "Simulate" test again.   <ol style="list-style-type: none"> <li>(1) If gauge functions properly test is complete. Install new CECU permanently. Re-test and <b>return truck to service</b>.</li> <li>(2) If gauge does not function properly during "Simulate" test, replace gauge.</li> </ol> </li> </ol> </li> </ol> </li> <li>6. Once gauge is replaced                             <ol style="list-style-type: none"> <li>a. Verify gauge functionality.</li> <li>b. <b>Return truck to service.</b></li> </ol> </li> <li>7. Is this a recheck after <b>Step 5, Step 6 or Step 7</b>?                             <ol style="list-style-type: none"> <li>a. Yes. <b>Return truck to service.</b></li> <li>b. No, Gauge and CVSG data link wiring is not the problem. Go to <b>Step 4</b>.</li> </ol> </li> </ol>							

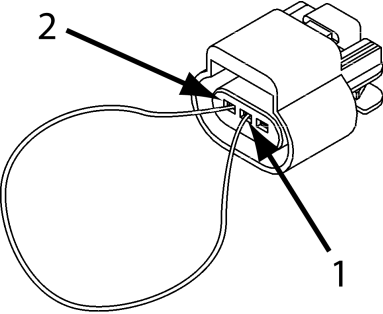
Step	Check	Result	Next Step
6	<p>Select "Diagnose" to view ammeter gauge DTCs.</p> <p>Next, unplug the ammeter connector at sensor.</p> <p>See <a href="#">CECU Pinout</a> for terminal details of the CECU electrical connections.</p>	<p>DTC <a href="#">257903</a> – Open in ammeter sensor circuit is displayed as "Active."</p>	<p>1. Using a jumper wire, jump across sensor harness connector Pins B and C.</p>  <p>1. Pin B 2. Pin C</p> <p>a. If an "Active" DTC <a href="#">257904</a> - Short in ammeter sensor circuit is now displayed, you have confirmed there is not an open in the sensor output voltage wire to the CECU. The original fault (DTC <a href="#">257903</a>) was logged because there is an open in the ammeter sensor itself, not the wiring. Replace sensor. Go to <b>Step 2</b>.</p> <p>b. If DTC <a href="#">257904</a> is not displayed, there is an open circuit in the wire between sensor connector Pin C and Pin 9 of the 52 Pin CECU connector C. Repair wiring as necessary. Go to <b>Step 2</b>.</p> <p><b>Alternate test method:</b> Check for continuity between sensor connector Pin C (sensor output voltage) and Pin 9 of the 52 Pin CECU connector C.</p> <p>1. If there is no continuity, repair wiring as necessary. After repairs, DTC <a href="#">257903</a> should now be displayed as "Inactive."</p> <p>2. If there is continuity between sensor connector Pin C and Pin 9 of the 52 Pin CECU connector C, the open circuit is in the sensor itself, not in the wiring. Replace sensor.</p>
7	<p>Select "Diagnose" to view ammeter gauge DTCs.</p> <p>Next, unplug the ammeter connector at sensor.</p> <p>See <a href="#">CECU Pinout</a> for terminal details of the CECU electrical connections.</p>	<p>DTC <a href="#">257904</a> - Short in ammeter sensor circuit is displayed as "Active."</p>	<p>If the fault is still "Active" after unplugging the sensor connector, you have confirmed there is a short to ground between Pin C (sensor output voltage) and Pin 9 of the 52 Pin CECU connector C</p> <p>1. Check for a pinched or chaffed wire between Pin C (sensor output voltage) and Pin 9 of the 52 Pin CECU connector C. Repair wiring as necessary. Go to <b>Step 2</b>.</p>
		<p>DTC <a href="#">257904</a> - Short in ammeter sensor circuit is now displayed as "Inactive."</p>	<p>If DTC <a href="#">257904</a> changes to "Inactive" after unplugging the sensor connector, you have confirmed the problem is a short in the sensor itself, not the wiring.</p> <p>1. Replace sensor. Go to <b>Step 2</b>.</p>

Return to [Table Of Contents](#)

## Rear Drive Axle Oil Temperature Gauge Inoperative

### DTC7703 and DTC7704

*Symptom: Rear drive axle oil temperature gauge inoperative. All other gauges are operational.*

The Rear Drive Axle Oil Temperature Gauge uses a thermistor sensor to measure axle oil temperature.

The following procedures have been developed to assist the technician in diagnosing multiplexed instrumentation problems using the Electronic Service Analyst (ESA) hardware/software diagnostic tool. It is assumed the service technician performing instrumentation repairs is knowledgeable about how to use ESA.

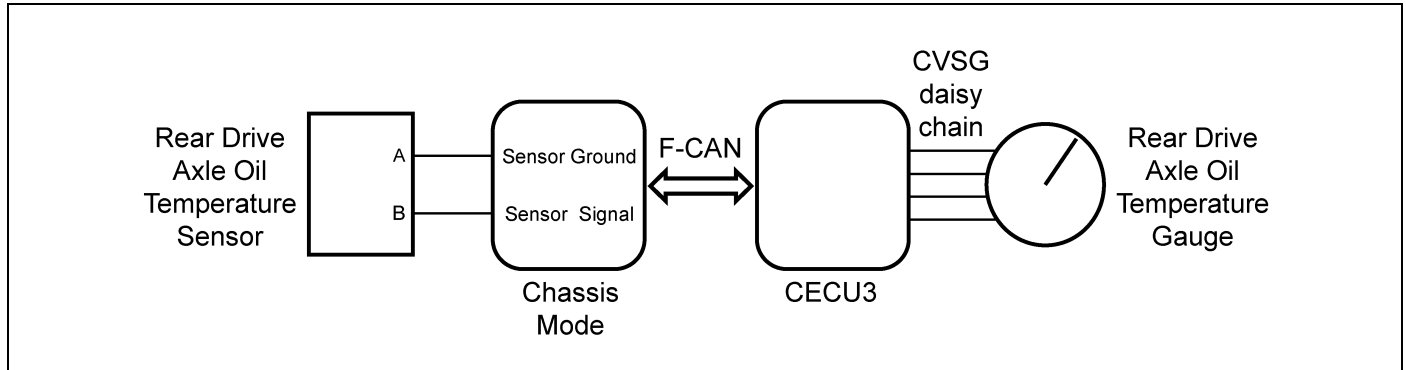

## Transmission Oil Temperature Gauge Inoperative

### DTC17703 and DTC17704

*Symptom: Transmission oil temperature gauge inoperative. All other gauges are operational.*

The Transmission Oil Temperature Gauge uses a thermistor sensor to measure transmission oil temperature.

The following procedures have been developed to assist the technician in diagnosing multiplexed instrumentation problems using the Electronic Service Analyst (ESA) hardware/software diagnostic tool. It is assumed the service technician performing instrumentation repairs is knowledgeable about how to use ESA.

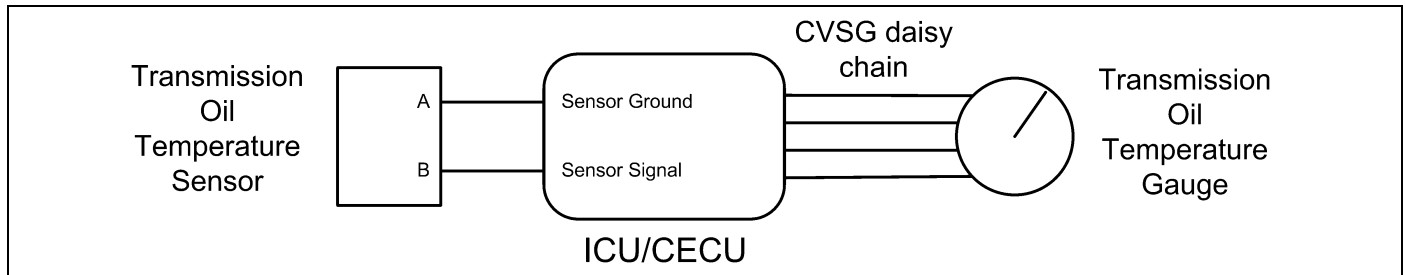

---

Return to [Table Of Contents](#)

Step	Check	Result	Next Step
1	Turn ignition key ON. Start ESA, then select "Connect" to establish communication to the vehicle.		Go to <b>Step 2</b> .
2	Select "Monitor." From the "Components" window, select "Brake Saver Oil Temperature," then select "Open."	Gauge graphic on screen displays reasonable reading.	Go to <b>Step 3</b> .
		Gauge graphic on screen does not display reasonable reading.	Go to <b>Step 4</b> .
3	Select "Simulate". Drag the "Value" bar until the pointer on the gauge image is approximately mid-scale. Observe vehicle gauge movement.	Vehicle gauge does not move. Go to <b>Step 3-1</b> . Vehicle gauge reading is in the same range as the ESA gauge image. Go to <b>Step 3-7</b> .	Perform the following checks: <ol style="list-style-type: none"> <li>1. Check CVSG data link wiring: Observe Gauge position in the wiring daisy chain. <ol style="list-style-type: none"> <li>a. If gauge is mounted between two other functioning gauges CVSG data link wiring is OK. Go to <b>Step 3-5</b>.</li> <li>b. If gauge is last gauge in daisy chain or followed by other non-functional gauges, go to <b>Step 3-2</b>.</li> </ol> </li> <li>2. Check continuity between Pin 1 on gauge harness connector and Pin 14 of the 52 Pin ICUconnector C.</li> <li>3. Check continuity between Pin 3 on gauge harness connector and Pin 15 of the 52 Pin ICUconnector C.</li> <li>4. Repair daisy chain jumper harness as necessary.</li> <li>5. Once continuity on both wires exists, perform "Simulate" test again. <ol style="list-style-type: none"> <li>a. If gauge functions properly during "Simulate" test, repair is complete. <b>Return truck to service.</b></li> <li>b. If gauge does not function during "Simulate" test, install a known good gauge and perform "Simulate" test again. <ol style="list-style-type: none"> <li>i. If gauge functions properly test is complete. Install new gauge permanently. Re-test and <b>return truck to service.</b></li> <li>ii. If gauge does not function during "Simulate" test, install Test ICU and perform "Simulate" test again. <ol style="list-style-type: none"> <li>(1) If gauge functions properly test is complete. Install new ICU permanently. Re-test and <b>return truck to service.</b></li> <li>(2) If gauge does not function properly during "Simulate" test, replace gauge.</li> </ol> </li> </ol> </li> <li>6. Once gauge is replaced. <ol style="list-style-type: none"> <li>a. Verify gauge functionality.</li> <li>b. <b>Return truck to service.</b></li> </ol> </li> <li>7. Is this a recheck after <b>Step 5, Step 6 or Step 7</b>? <ol style="list-style-type: none"> <li>a. Yes. <b>Return truck to service.</b></li> <li>b. No, Gauge and CVSG data link wiring is not the problem. Go to <b>Step 4</b>.</li> </ol> </li> </ol> </li></ol>
4	Select "Diagnose" to view brake saver oil temperature gauge diagnostic trouble codes.	DTC 138703 displayed - Open in brake saver oil temp circuit.	Indicates the problem could be an open in the wiring from the CECU to the sensor or a defective sensor. Go to <b>Step 5</b> , and if necessary, <b>Step 6</b> .
		DTC 138704 displayed - Short in brake saver oil temp circuit.	Indicates the problem could be a short to ground in the wiring from the CECU to the sensor or a defective sensor. Go to <b>Step 5</b> , and if necessary, <b>Step 7</b> .

Step	Check	Result	Next Step
			2. If there is continuity between sensor connector Pin A and Pin 6 of the Chassis Node connector A, the open circuit is in the sensor itself, not in the wiring. Replace sensor.
7	Select "Diagnose" to view primary fuel level gauge DTCs. Next, unplug the fuel gauge harness connector at sensor. See <a href="#">Chassis Node Pinout</a> for terminal details of the Chassis Node electrical connections.	DTC 82904 - Short in primary fuel level circuit is displayed as "Active."	If the fault is still "Active" after unplugging the sensor connector, you have confirmed there is a short to ground between Pin A (sensor signal) and Pin 6 of the Chassis Node connector A. 1. Check for a pinched or chaffed wire between Pin A (sensor signal) and Pin 6 of the Chassis Node connector A, Repair wiring as necessary. Go to <b>Step 2</b> .
		DTC 82904 - Short in primary fuel level circuit is now displayed as "Inactive."	If DTC 82904 changes to "Inactive" after unplugging the sensor connector, you have confirmed the problem is a short in the sensor itself, not the wiring. 1. Replace sensor. Go to <b>Step 2</b> .

[Return to Table Of Contents](#)

Step	Check	Result	Next Step
7	Select "Diagnose" to view outside air temperature DTCs. Unplug outside air temperature harness connector at mirror harness to instrument panel harness connector. See <a href="#">CECU Pinout</a> for terminal details of the CECU electrical connections.	DTC <a href="#">17104</a> – Short in outside air temperature circuit is displayed as "Active".	If the fault is still "Active" after unplugging the sensor connector, you have confirmed there is a short to ground between Pin A (sensor signal) and Pin 16 of the 52 Pin CECU connector C. <ol style="list-style-type: none"> <li>1. Check for a pinched or chaffed wire between Pin A (sensor signal) and Pin 16 of the 52 Pin CECU connector C. Repair wiring as necessary. Go to <b>Step 2</b>.</li> </ol>
		DTC <a href="#">17104</a> – Short in outside air temperature circuit is now displayed as "Inactive".	If DTC 17104 changes to "Inactive" after unplugging the sensor connector, you have confirmed the problem is a short in the sensor itself, not the wiring. Replace the sensor. Go to <b>Step 2</b> .

Return to [Table Of Contents](#)

CLICK HERE TO **DOWNLOAD** THE COMPLETE MANUAL

- Thank you very much for reading the preview of the manual.
- You can download the complete manual from: [www.heydownloads.com](http://www.heydownloads.com) by clicking the link below



- Please note: If there is no response to CLICKING the link, please download this PDF first and then click on it.

CLICK HERE TO **DOWNLOAD** THE COMPLETE MANUAL