

Department	Customer Service
Category	Service Manual
Section	Electrical
Title	Electrical System
Number	<b>KM815001</b>
Date	06/18/03
Model	All
Page	1 of 70

# Service Manual

## Electrical System

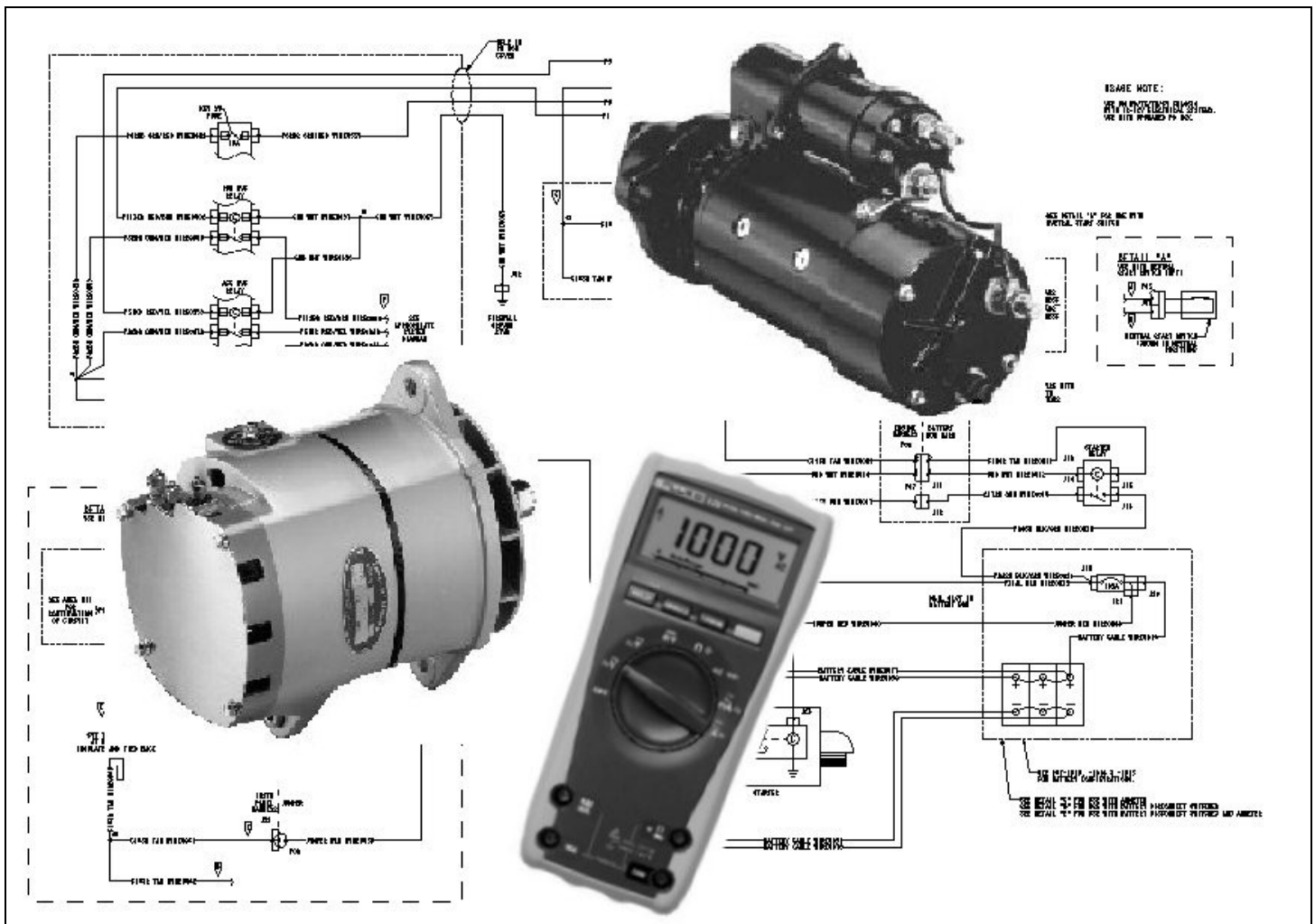

### Table of Contents

### Meters 8

- Theory Of Operation 3
  - Generating Electricity 3
  - Voltage, Current, Resistance 4
  - Types Of Circuits 4
  - Electrical System Failures 6
- Troubleshooting Tools 8
  - Wiring Diagrams 8

- Test Light 12
- Hydrometer 12
- Diagnosis / Testing 14
  - Systematic Plan 14
  - Common Point Analysis 14
  - Substitution Test 14
  - Voltage Tests 14
  - Open Circuit Test 17

CLICK HERE TO **DOWNLOAD** THE COMPLETE MANUAL

- Thank you very much for reading the preview of the manual.
- You can download the complete manual from: [www.heydownloads.com](http://www.heydownloads.com) by clicking the link below



- Please note: If there is no response to CLICKING the link, please download this PDF first and then click on it.

CLICK HERE TO **DOWNLOAD** THE COMPLETE MANUAL

## Electrical: Electrical System

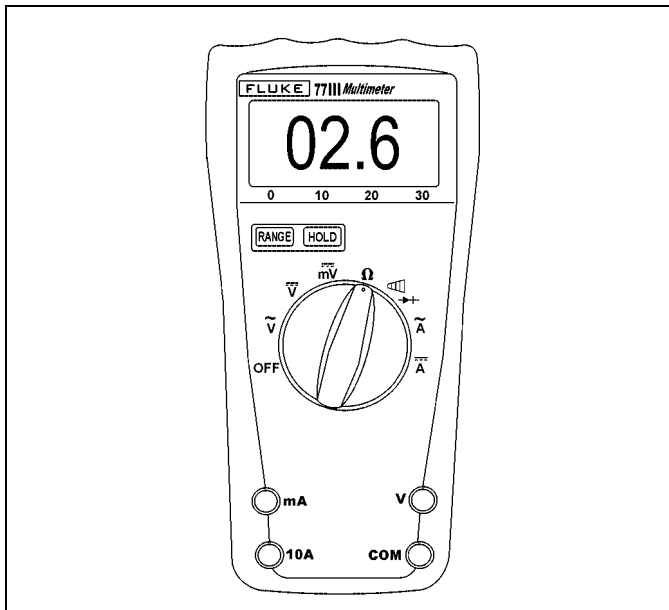

Figure 15-20

### Continuity Testing

The ohmmeter can also be used for continuity testing. Most digital multimeters have a rotary switch position that provides an "audible" tone when there is circuit continuity. A continuous tone sounds if the resistance between the terminals is less than approximately 150 ohms (100 counts in the display). In Touch Hold, two continual beeps indicates circuit continuity.

When testing a diode, use the "audible" tone switch position instead of the Ohm ( $\Omega$ ) switch position. See [Figure 15-21](#).

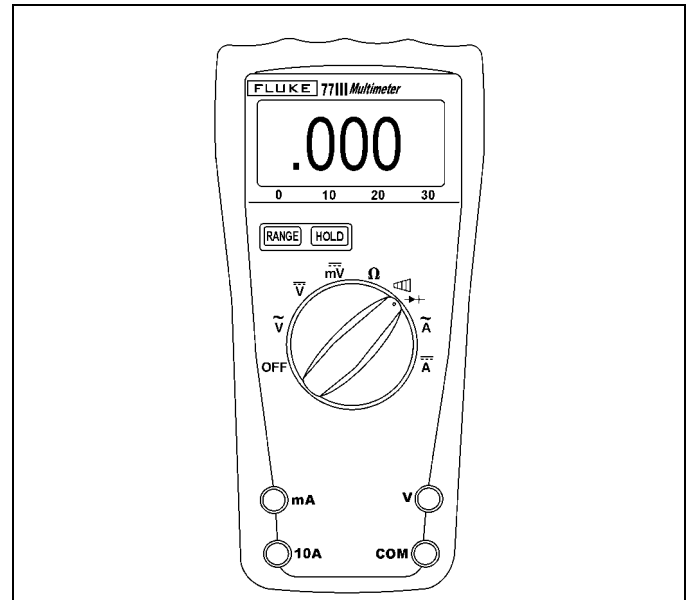

Figure 15-21

### VAT Tester

A volt amp tester or VAT is a multipurpose tester that consists of a voltmeter with internal and external voltage leads, an ammeter with an inductive pickup, and a carbon pile. The carbon pile is a variable resistor designed to carry high current flow for a short duration. This unit is an effective tool for testing batteries, starting circuits and charging circuits.

To use a VAT tester, connect the large tester leads to the battery, starter, or alternator terminals. This is dependent on the component test being performed. The ammeter inductive pickup should be clamped securely around the wire that you want to read current flow in. Ensure the arrow on the inductive pickup is pointing in the direction of current flow. The voltage selector switch should be in the *internal* voltage position to read voltage at where the large tester leads are connected. The voltage selector

Electrical: Electrical System

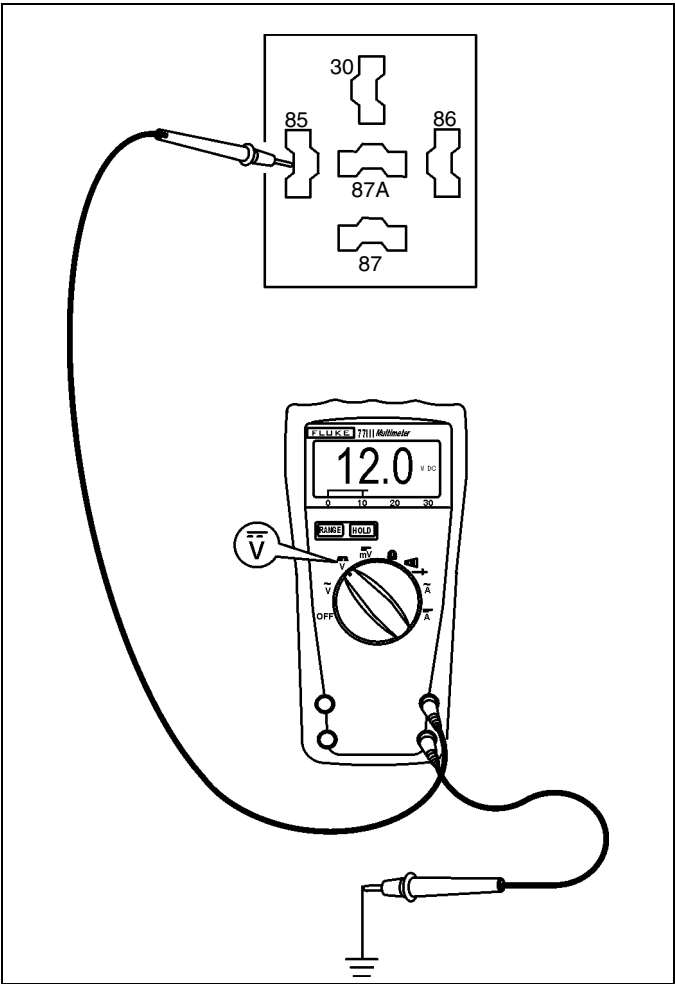

Figure 15-44

If there is voltage at the power side of the relay control circuit, use a self-powered test light, jumper wire or ohmmeter to check for a faulty ground, a defective control switch or an open wire in the control coil ground circuit. See [Figure 15-45](#) and [Figure 15-46](#).

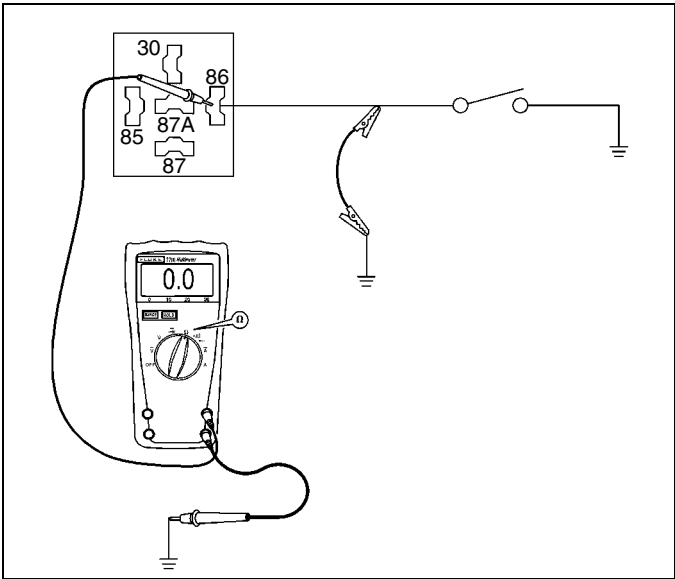

Figure 15-45

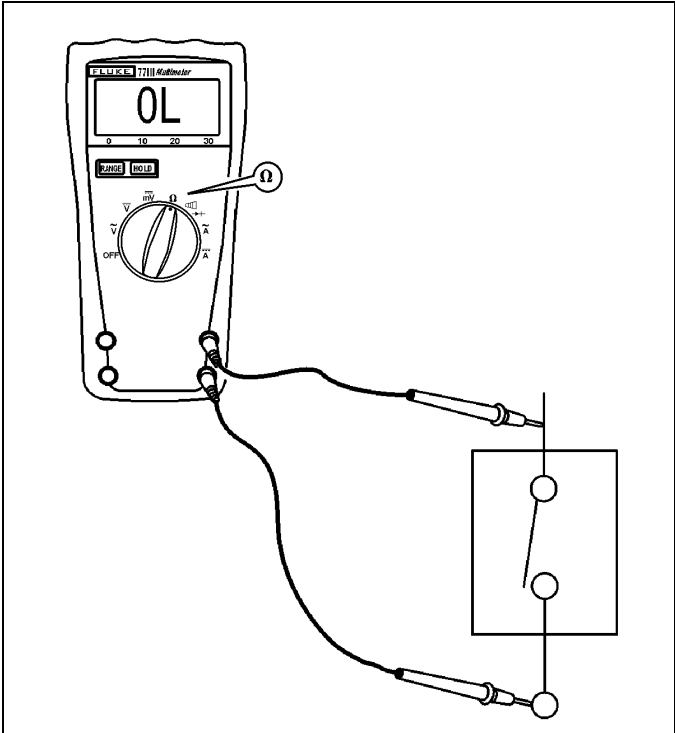

Figure 15-46

## Electrical: Electrical System

Circuit No.	Circuit Description	Color Code
189.	not used	
190.	Door Lock Actuator Feed Wire "B"	Blue/Red
191.	Door Lock Actuator Feed Wire "A"	Green/Red
192.	Door Unlock	Black/Red
193.	Door Lock	White/Red
194.	Door Unlock Relay Ground	Brown/Red
195.	Door Lock Relay Ground	Black/Red
196.	Air Bag Warning Lamp	Blue/Yellow
197.	Air Bag Battery Power	Red/Yellow
198.	Air Bag Ignition Power	Orange/Yellow
199.	Air Bag Firing Circuit	Yellow/Pink
200.	Seat Belt Switch	Yellow/Brown
201.	Aux Input	Gray/Green
202.	Aux Output	Gray/Yellow
203.	Transmission Shift Modulation	Purple/Lt.Blue
204.	Transmission In Gear	Purple/Green
205.	Low Coolant Low	Blue/Black
206.	Low Coolant High	Blue/White
207.	+5 VDC	Blue/Red
208.	Return	Blue/Green
209.	not used	
210.	Maintenance Indicator Lamp	Green/Red
211.	Water-In-Fuel Indicator Lamp	Green/Yellow
212.	Proprietary Can Bus (High)	Red
213.	Proprietary Can Bus (Low)	Black
214.	Proprietary Can Bus (Shield)	White
215.	PTO Lamp	Brown/Blue
216.	Remote PTO Set	Brown/Lt. Green
217.	Remote PTO Resume	Brown/Lt. Yellow
218.	not used	
219.	Input Sensor Common #1	White/Purple
220.	Input Sensor Common #2	White/Orange
221.	Trans Shift Solenoid	Tan/Purple
222.	Trans Position Sensor	Tan/Lt. Green

Circuit No.	Circuit Description	Color Code
223.	Auto Trans Man Override	Tan/Blue
224.	not used	
225.	not used	
226.	Engine Governor Switch	Orange/Blue
227.	not used	
228.	Collision Warning Power	Red/Purple
229.	Collision Warning Bus Positive	Orange/Lt. Blue
230.	Collision Warning Bus Negative	Black/Tan
231.	Collision Warning Side Sensor Power, Primary	Red/Lt. Green
232.	Collision Warning Side Sensor Ground, Primary	Violet/Lt. Green
233.	Collision Warning Side Sensor Signal, Primary	Purple/Lt. Green
234.	Collision Warning Side Sensor Power, Secondary	Red/White
235.	Collision Warning Side Sensor Ground, Secondary	Violet/White
236.	Collision Warning Side Sensor Signal, Secondary	Purple/White
237.	Collision Warning Driver's Display Unit Power	Purple/Tan
238.	Collision Warning Side Sensor Display Signal, Primary	Green/Purple
239.	Collision Warning Side Sensor Display Signal, Secondary	Gray/Purple
240.	Collision Warning Front Sensor Power	Red/Yellow
241.	Collision Warning Front Sensor Ground	Violet/Yellow
242.	not used	
243.	not used	
244.	Engine Condensation Actuator	Orange/Lt. Green
245.	Engine Turbo Control Actuator	Pink/Brown
246.	Engine EGR Actuator	Green/Violet
247.	Engine EGR Bypass Actuator	Blue/Orange
248.	Engine Oxygen Sensor	Yellow/Brown
249.	Engine Mass Air Flow Sensor	Pink/Lt. Blue



## Electrical: Electrical System

---

### Volt Drop Test

Use the diagram in [Figure 15-59](#).

1. With the engine running at a fast idle, connect the voltmeter positive (+) lead to the alternator battery or positive (+) terminal. Connect the voltmeter negative (-) lead to the positive (+) terminal on the battery. (Meter 1)
2. Record the meter reading.
3. Connect the voltmeter positive (+) lead to the ground terminal on the alternator. Connect the voltmeter negative (-) lead to the negative (-) terminal on the battery. (Meter 2)
4. Run engine at fast idle and record meter reading.

ADD

Positive Cable Volt Loss \_\_\_\_\_ volts (Meter 1)

Negative Cable Volt Loss \_\_\_\_\_ volts (Meter 2)

---

Total System Loss \_\_\_\_\_ (0.5 max)



CLICK HERE TO **DOWNLOAD** THE COMPLETE MANUAL

- Thank you very much for reading the preview of the manual.
- You can download the complete manual from: [www.heydownloads.com](http://www.heydownloads.com) by clicking the link below



- Please note: If there is no response to CLICKING the link, please download this PDF first and then click on it.

CLICK HERE TO **DOWNLOAD** THE COMPLETE MANUAL