Electrical Circuit Diagrams

ProStar® and LoneStar® - Models Built June 14, 2010 and After
Engine Family: MaxxForce® 11, 13, and 15L, Cummins ISX, and N13

Navistar, Inc.

2701 Navistar Drive, Lisle, IL 60532 USA

CLICK HERE TO **DOWNLOAD** THE COMPLETE MANUAL

- Thank you very much for reading the preview of the manual.
- You can download the complete manual from: www.heydownloads.com by clicking the link below



- Please note: If there is no response to CLICKING the link, please download this PDF first and then click on it.

CLICK HERE TO **DOWNLOAD** THE COMPLETE MANUAL

TABLE OF CONTENTS (CONT.)

11.14. ALLISON TRANSMISSION (2010 SCR 13L ENG) (CONT.), P. 10.....	376
11.15. ALLISON TRANSMISSION (2010 SCR 13L ENG) (CONT.), P. 11.....	377
11.16. ALLISON TC10 TRANSMISSION, P. 12.....	378
11.17. ALLISON TC10 TRANSMISSION (CONT.), P. 13.....	379
11.18. ALLISON TC10 TRANSMISSION (CONT.), P. 13A.....	380
12. HVAC (CHAPTER 12).....	381
12.1. AIR CONDITIONING, P. 1.....	381
12.2. HVAC SYSTEM – CAB, P. 2.....	382
12.3. HVAC SYSTEM – CAB (CONT.), P. 3.....	383
12.4. HVAC SYSTEM – SLEEPER, P. 4.....	384
12.5. HVAC SYSTEM – SLEEPER (CONT.), P. 5.....	385
12.6. NO IDLE HEAT AND HVAC – SWITCHES, P. 6.....	386
12.7. NO IDLE HEAT AND HVAC – APU, P. 7.....	387
12.8. NO IDLE HEAT AND HVAC – SENSORS AND HVAC CONTROL, P. 8.....	388
12.9. HVAC TEMPERATURE SENDER, P. 8A.....	389
12.10. NO IDLE HEAT AND HVAC – POWER SUPPLY, P. 9.....	390
12.11. NO IDLE HEAT AND HVAC – HEAT VALVE, LPM AND BLEND MOTOR, P. 10.....	391
12.12. NO IDLE HEAT AND HVAC – FUEL FIRED HEATER AND A/C COMPRESSOR, P. 11.....	392
12.13. NO IDLE HEATER, ESPAR IN CAB FUEL FIRED HEATER, P. 12.....	393
12.14. NO IDLE HEATER, ESPAR IN CAB FUEL FIRED HEATER WIRED FOR KEY OFF MODE, P. 12A.....	394
12.15. NO IDLE HEATER, WEBASTO IN CAB FUEL FIRED HEATER, P. 13.....	395
12.16. NO IDLE HEATER, WEBASTO IN CAB FUEL FIRED HEATER WITH LVD, P. 14.....	396
12.17. HVAC SYSTEM – SLEEPER WITH BERGSTROM NO IDLE WITH PROSTAR, P. 15.....	397
12.18. HVAC SYSTEM – SLEEPER WITH BERGSTROM NO IDLE, P. 15A.....	398
12.19. HVAC SYSTEM – SLEEPER WITH BERGSTROM NO IDLE SWITCHES – LOCATED IN SLEEPER CONTROL PANEL, P. 16.....	399
12.20. HVAC SYSTEM – SLEEPER WITH BERGSTROM NO IDLE SWITCHES – LOCATED IN SLEEPER CONTROL PANEL (CONT.), P. 17.....	400
12.21. HVAC SYSTEM – SLEEPER WITH BERGSTROM NO IDLE POWER SUPPLY 12V, P. 18....	401
12.22. HVAC SYSTEM – SLEEPER WITH BERGSTROM NO IDLE POWER SUPPLY 12V (CONT.), P. 18A.....	402
12.23. HVAC SYSTEM – SLEEPER WITH BERGSTROM NO IDLE FUEL FIRED HEATER, P. 19...	403
12.24. IDLE MANAGEMENT WITH NO IDLE 12V DC NOT WITH AUTO SEVERE SERVICE LONESTAR, P. 20.....	404
12.25. IDLE MANAGEMENT WITH NO IDLE 12V DC NOT WITH AUTO SEVERE SERVICE LONESTAR (CONT.), P. 21.....	405
12.26. IDLE MANAGEMENT WITH NO IDLE 110V AND SLEEPER BOX NO IDLE ISOLATED BATTERY AND GROUND, P. 22.....	406
12.27. SLEEPER BOX WITH NO IDLE 12V DC WITH AUTO SEVERE SERVICE LONESTAR, P. 23.....	407
12.28. HVAC-CONDENSATION MODULE FOR ESPAR AND WEBASTO NO IDLE HEAT, P. 24.	408
12.29. SLEEPER WIRING WITH NO IDLE DASH SWITCH, P. 25.....	409
12.30. ESPAR HEATER WITH DAYCAB, P. 26.....	410
13. BUNK LIGHTS AND ACCESSORIES (CHAPTER 13).....	411
13.1. READING AND WARDROBE LIGHTS – BUNK, P. 1.....	411
13.2. LUGGAGE COMPARTMENT LIGHTS – BUNK, P. 2.....	412
13.3. POWER SOURCE – BUNK, P. 3.....	413
13.4. TELEVISION / REFRIGERATOR WIRING, P. 4.....	414

2.3. CIRCUIT DIAGRAM INSTRUCTIONS, P. 3

NAVISTAR, INC

THIS PRINT IS PROVIDED ON A RESTRICTED BASIS AND IS NOT TO BE USED IN ANY WAY DETRIMENTAL TO THE INTEREST OF NAVISTAR, INC.

ELECTRICAL CIRCUIT DIAGRAM

CHAPTER 2

CIRCUIT DIAGRAM INSTRUCTIONS

A - SWITCH AND RELAY POSITIONS AS SHOWN ON CIRCUIT DIAGRAMS INDICATE NORMAL POSITION WITH IGNITION OFF UNLESS OTHERWISE NOTED.

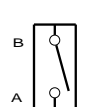

SWITCH, MECHANICAL

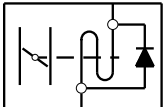

SOLENOID

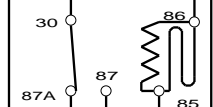

RELAY - SUPPRESSED

B - MULTIPLE CONNECTIONS ARE DISPLAYED ON SCHEMATIC AS SHOWN WITH R/D NUMBER & CAVITY NUMBER. REFER TO CONNECTOR COMPOSITE FOR MORE INFORMATION

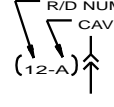

R/D NUMBER
CAVITY NUMBER
(12-A)

AND/OR

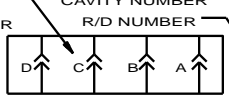

CAVITY NUMBER
R/D NUMBER
D C B A (12)

SINGLE IN-LINE CONNECTORS DISPLAYED AS SHOWN BELOW WITHOUT R/D NUMBER



C - PHANTOM LINES INDICATE PRINTED CIRCUITS OR BUSSED CIRCUITS. THESE CIRCUITS EXIST IN THE INSTRUMENT CLUSTER AND FUSE / CIRCUIT BREAKER CONNECTORS.

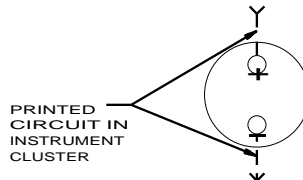

PRINTED CIRCUIT IN INSTRUMENT CLUSTER



VOLTMETER

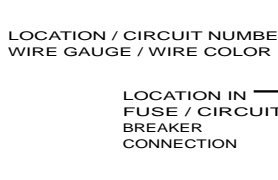

LOCATION / CIRCUIT NUMBER
WIRE GAUGE / WIRE COLOR

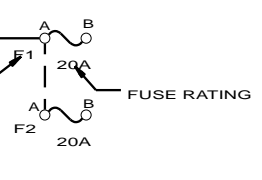

LOCATION IN FUSE / CIRCUIT BREAKER CONNECTION

FUSE RATING
20A

D - MULTIPLE CIRCUIT NUMBERS ON A LINE INDICATE ONE CIRCUIT DISTRIBUTING CURRENT TO TWO CIRCUITS.

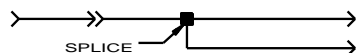

SPLICE

E - SWITCHES, RELAYS AND COMPONENTS INDICATE EXTERNAL WIRE CONNECTIONS AND / OR INTERNAL CONNECTIONS OR CONTACTS.

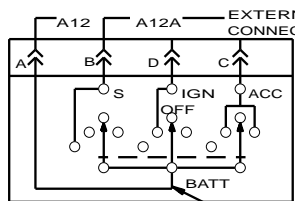

KEY SWITCH (1101M)

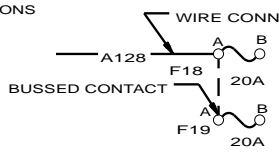

WIRE CONNECTION

BUSSED CONTACT

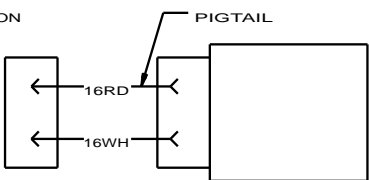

PIGTAIL

16RD

16WH



INTERNAL CONNECTION

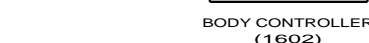

BODY CONTROLLER (1602)

F - CIRCUIT "11" DENOTES ANY COMMON GROUND (MORE THAN ONE CIRCUIT). ANY INDIVIDUAL GROUND CIRCUIT IS IDENTIFIED WITH THAT PARTICULAR CIRCUIT NUMBER. (E.G. CIRCUIT 32 CRUISE CONTROL IS IDENTIFIED AS PER EXAMPLE)



COMMON GROUND CIRCUIT NUMBER

11-G
11-GA
11-GB



SUFFIX BEGINNING WITH G INDICATES A GROUND CIRCUIT



INDIVIDUAL GROUND CIRCUIT NUMBER

R32-G
R32-GA
R32-GB



SUFFIX BEGINNING WITH G INDICATES A GROUND CIRCUIT

NOTE: FOR CIRCUIT DESCRIPTION OTHER THAN GROUNDS NEITHER THE LETTER "G" NOR THE COLOR WHITE SHALL BE USED

CHK	DATE	CHANGE	REV	REFERENCE	DRAWN	NAME		
0486	30DEC11	TITLE WAS CIRCUIT	B	82357E	300422	CIRCUIT DIAGRAM, PROSTAR, LONESTAR		
					RELEASE NO.	DATE	PART NO.	SHEET
		DIAGRAM, PROSTAR.			61802Y	09MAR09	AE08058095	003

Figure 3 Circuit Diagram Instructions

3.11. IGNITION FEED WITH 500K BAUD RATE, P. 5B

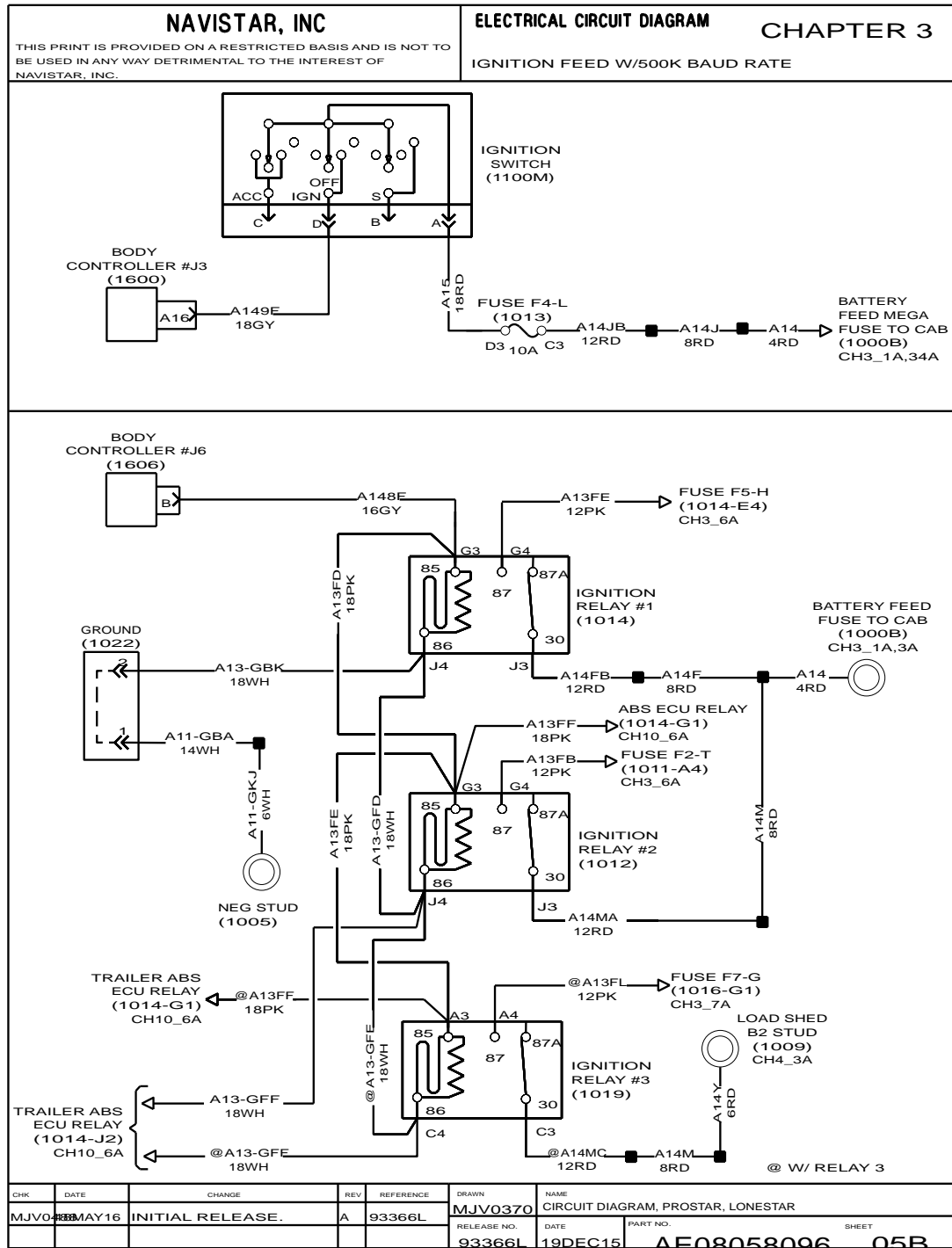

Figure 23 Ignition Feed with 500K Baud Rate

3.21. ACCESSORY FEED WITH 500K BAUD RATE, P. 9B

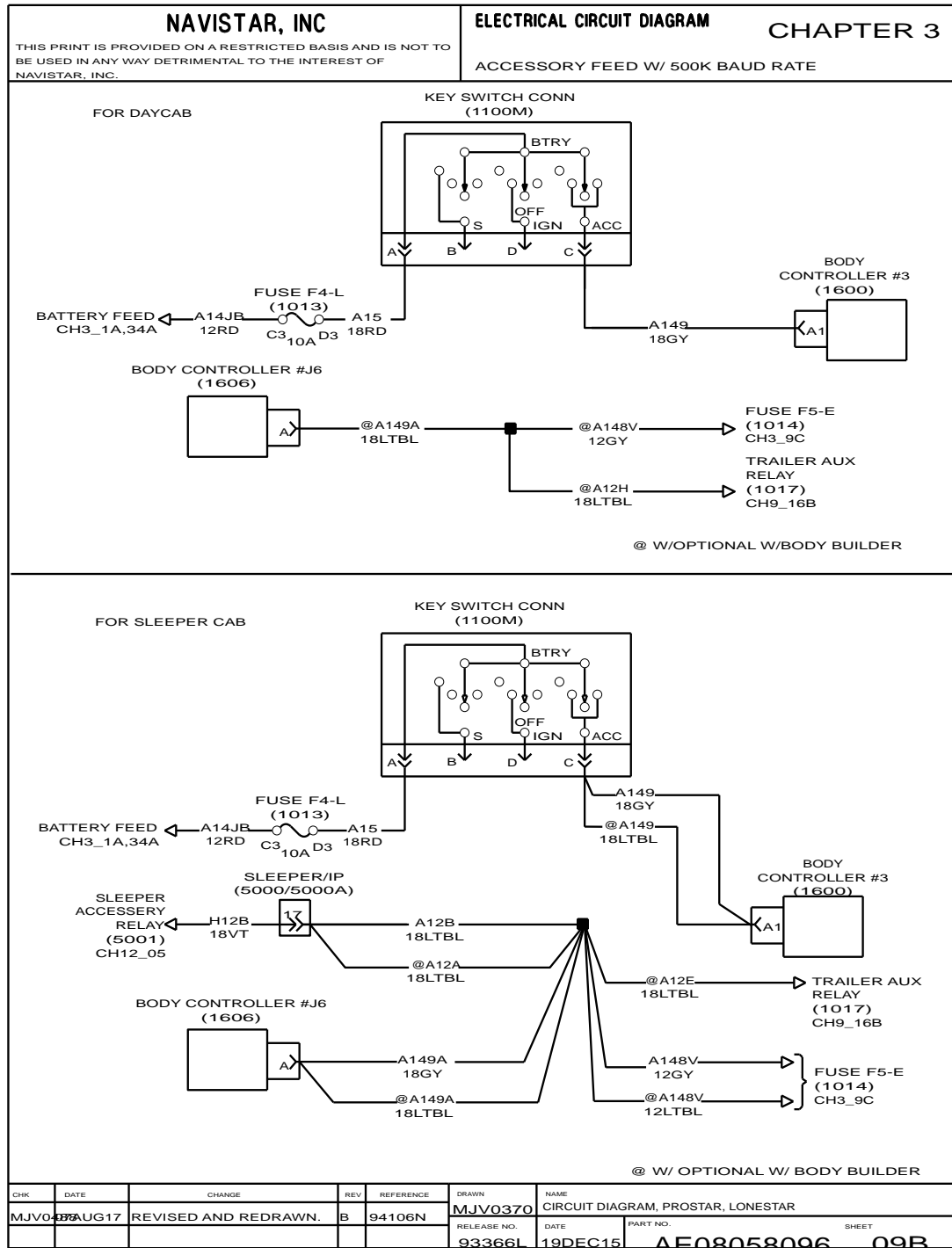

Figure 33 Accessory Feed with 500K Baud Rate

3.31. CAB J1939 ENGINE – ISX, P. 14A

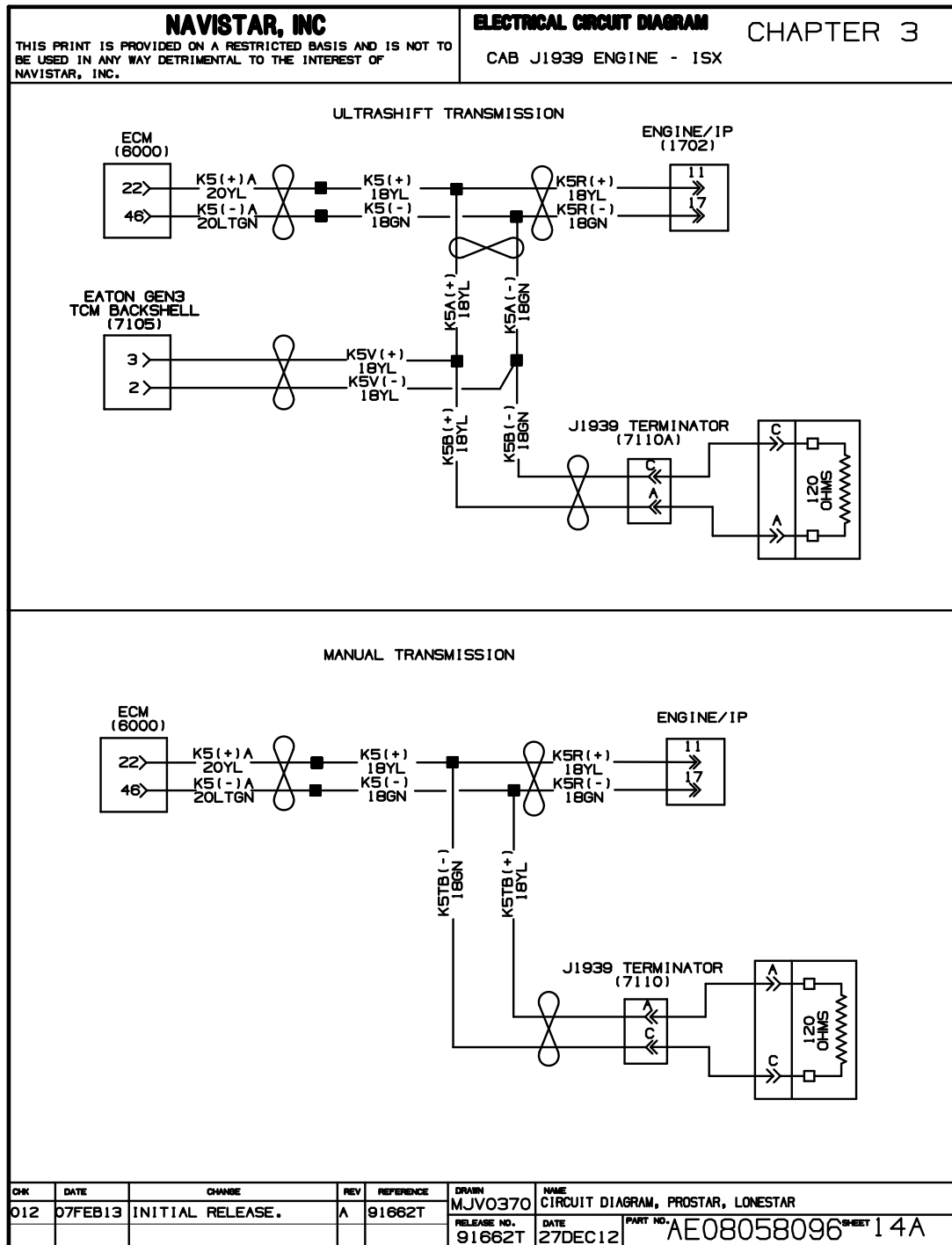

Figure 43 Cab J1939 Engine – ISX

3.41. J1708 PUBLIC (CONT.), P. 19

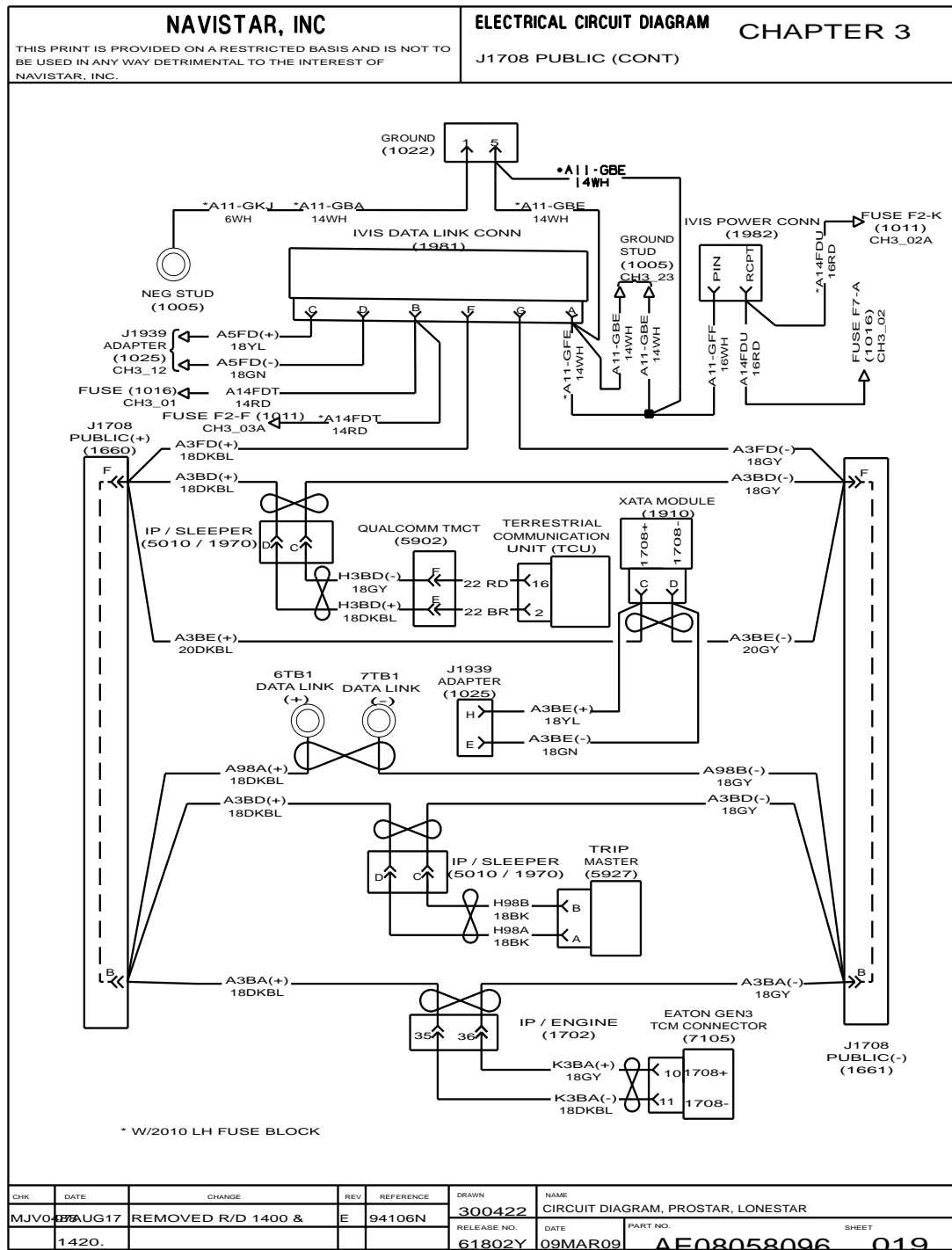

Figure 53 J1708 Public (Cont.)

3.51. GROUND – SLEEPER (CONT.), P. 29

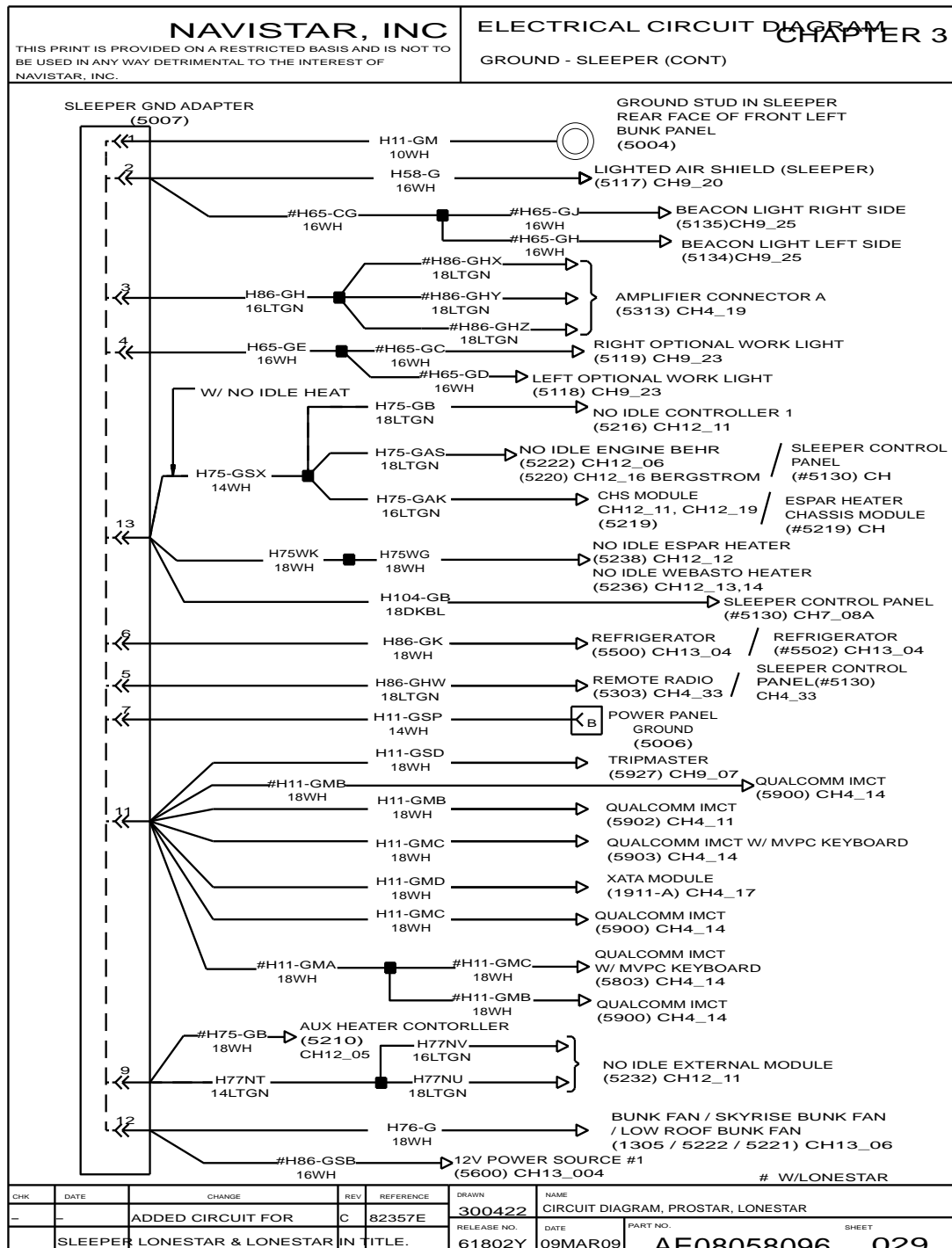

Figure 63 Ground – Sleeper (Cont.)

3.61. GROUND ADAPTER - ISX ENGINE (CONT.), P. 37

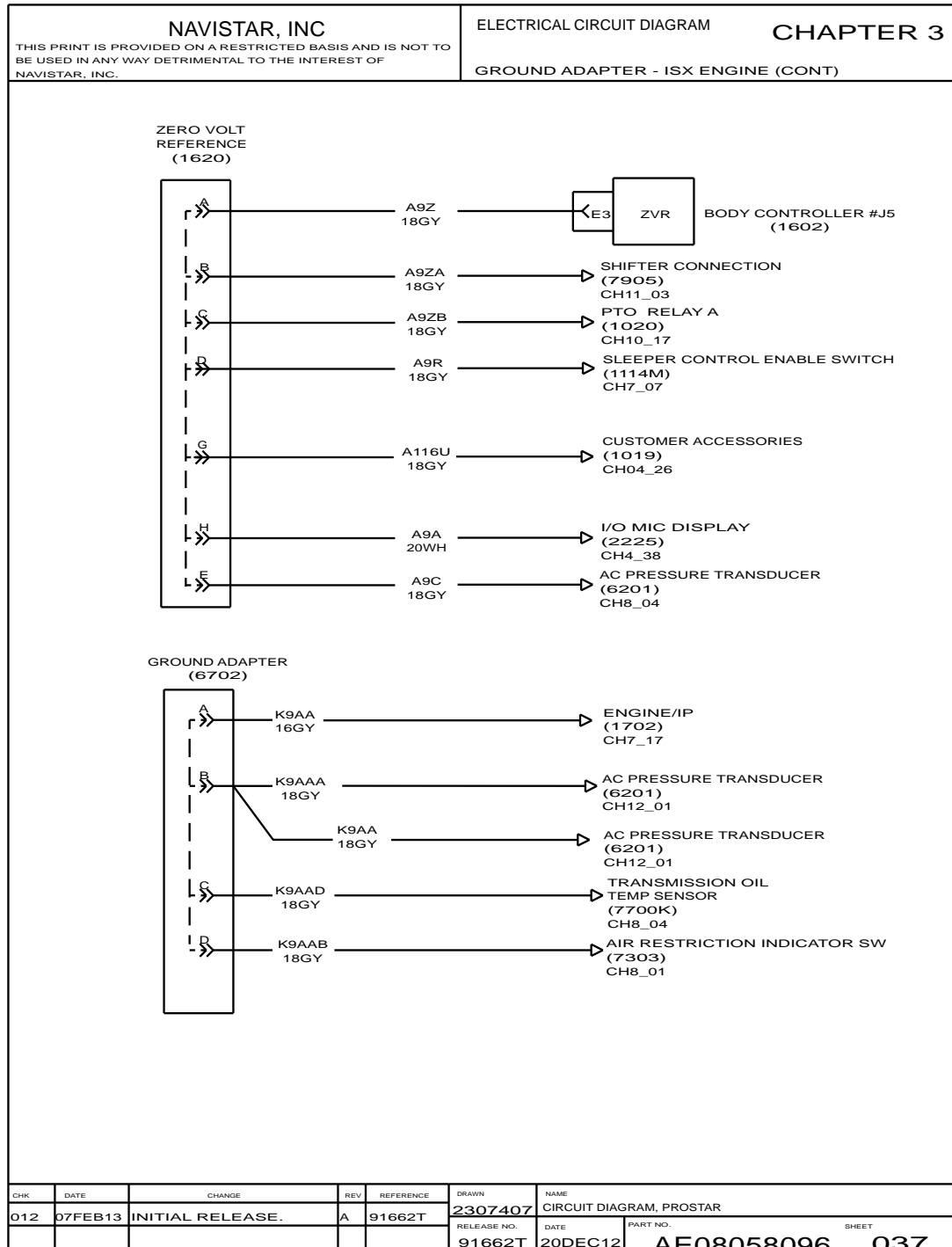

Figure 73 Ground Adapter - ISX Engine (Cont.)

3.71. CAB J1939 500K WIRING (CONT.), P. 47

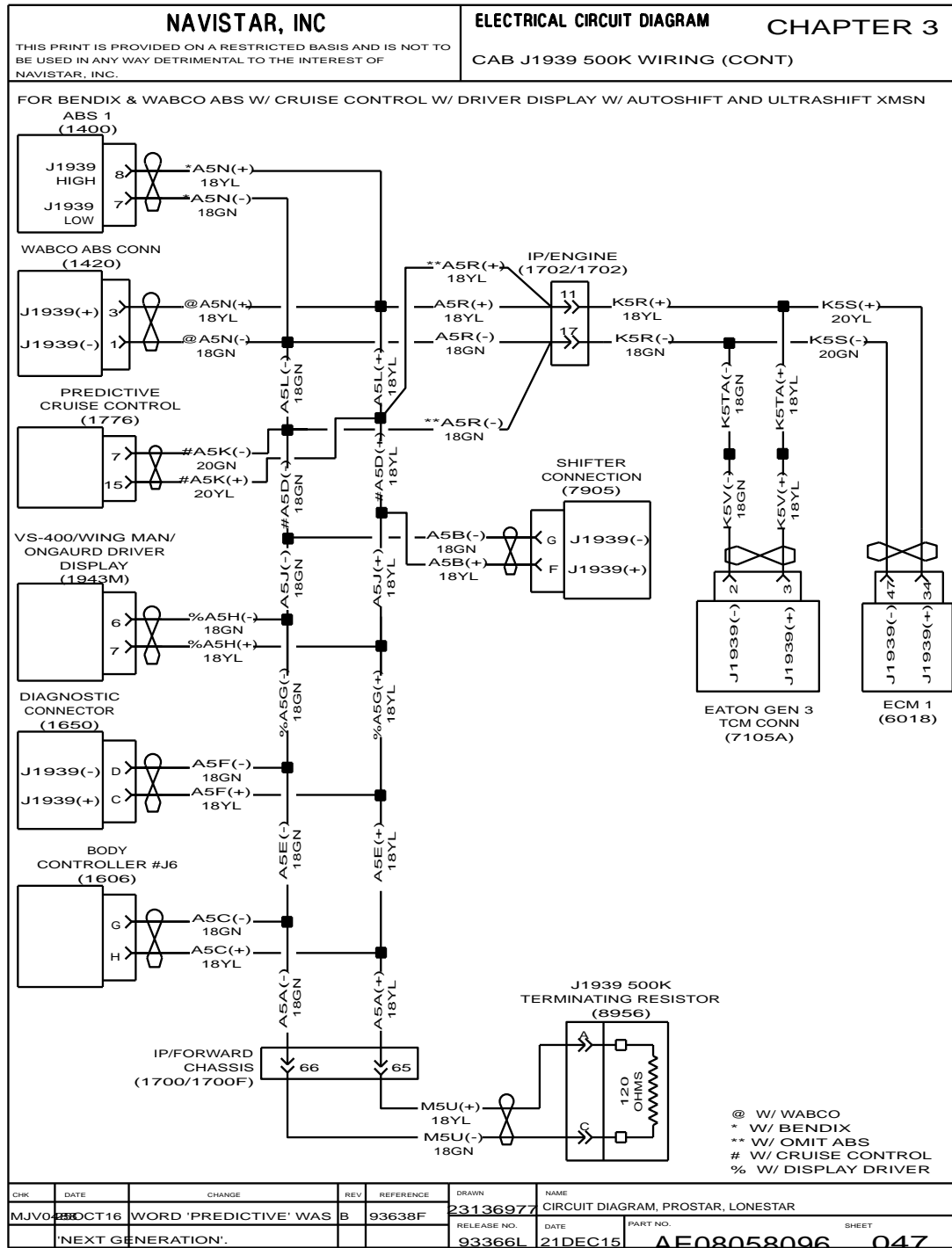

Figure 83 Cab J1939 500K Wiring (Cont.)

3.81. CAB J1939 250K WIRING (CONT.), P. 57

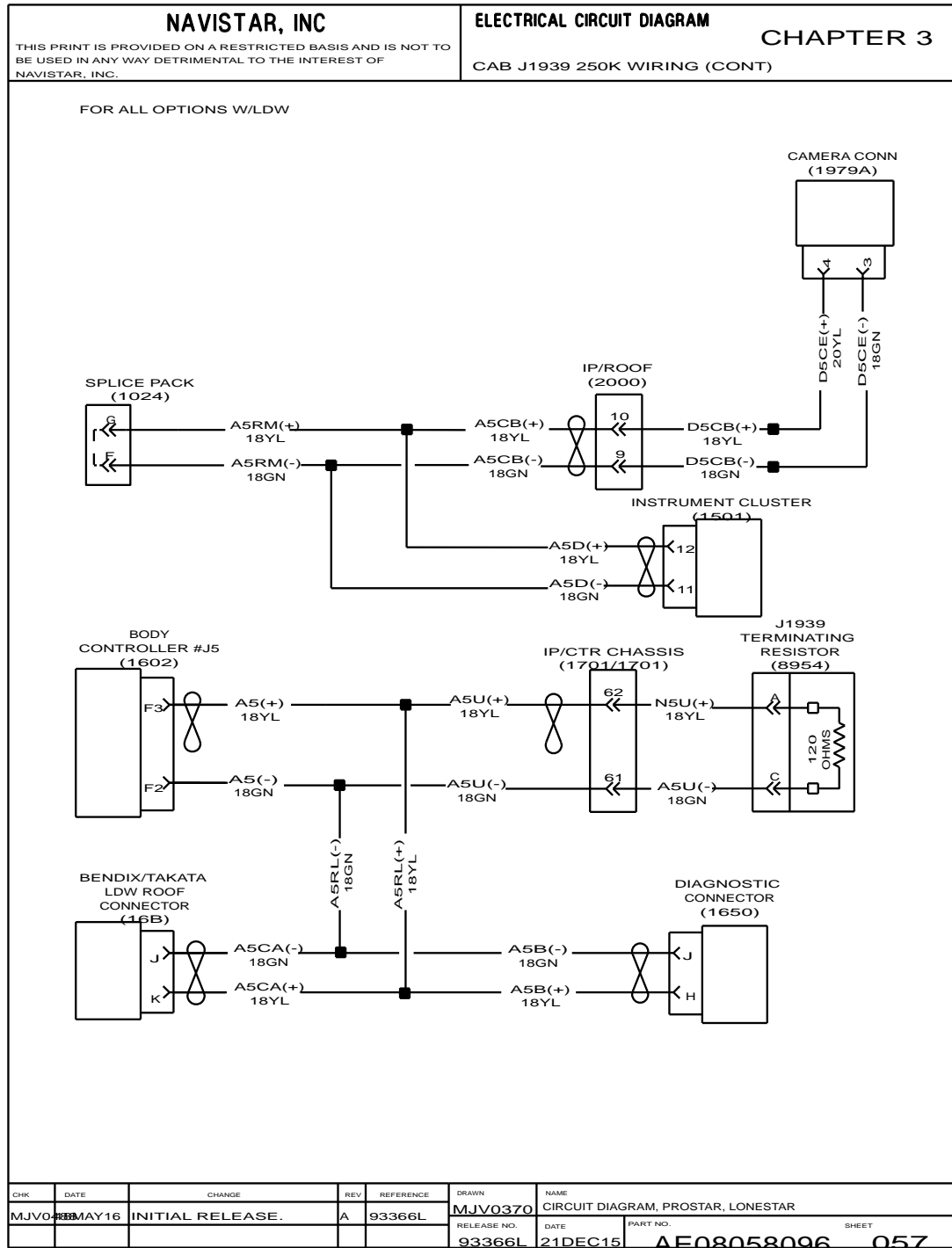

Figure 93 Cab J1939 250K Wiring (Cont.)

4.9. INTENTIONALLY LEFT BLANK, P. 7

NAVISTAR, INC				ELECTRICAL CIRCUIT DIAGRAM		CHAPTER 4	
THIS PRINT IS PROVIDED ON A RESTRICTED BASIS AND IS NOT TO BE USED IN ANY WAY DETRIMENTAL TO THE INTEREST OF NAVISTAR, INC.				INTENTIONALLY LEFT BLANK			
INTENTIONALLY LEFT BLANK							
CHK	DATE	CHANGE	REV	REFERENCE	DRAWN	NAME	
					RELEASE NO.	DATE	PART NO. SHEET

Figure 103 Intentionally Left Blank

4.19. COMMUNICATIONS SYSTEM, WIRING (CONT.) , P. 14B

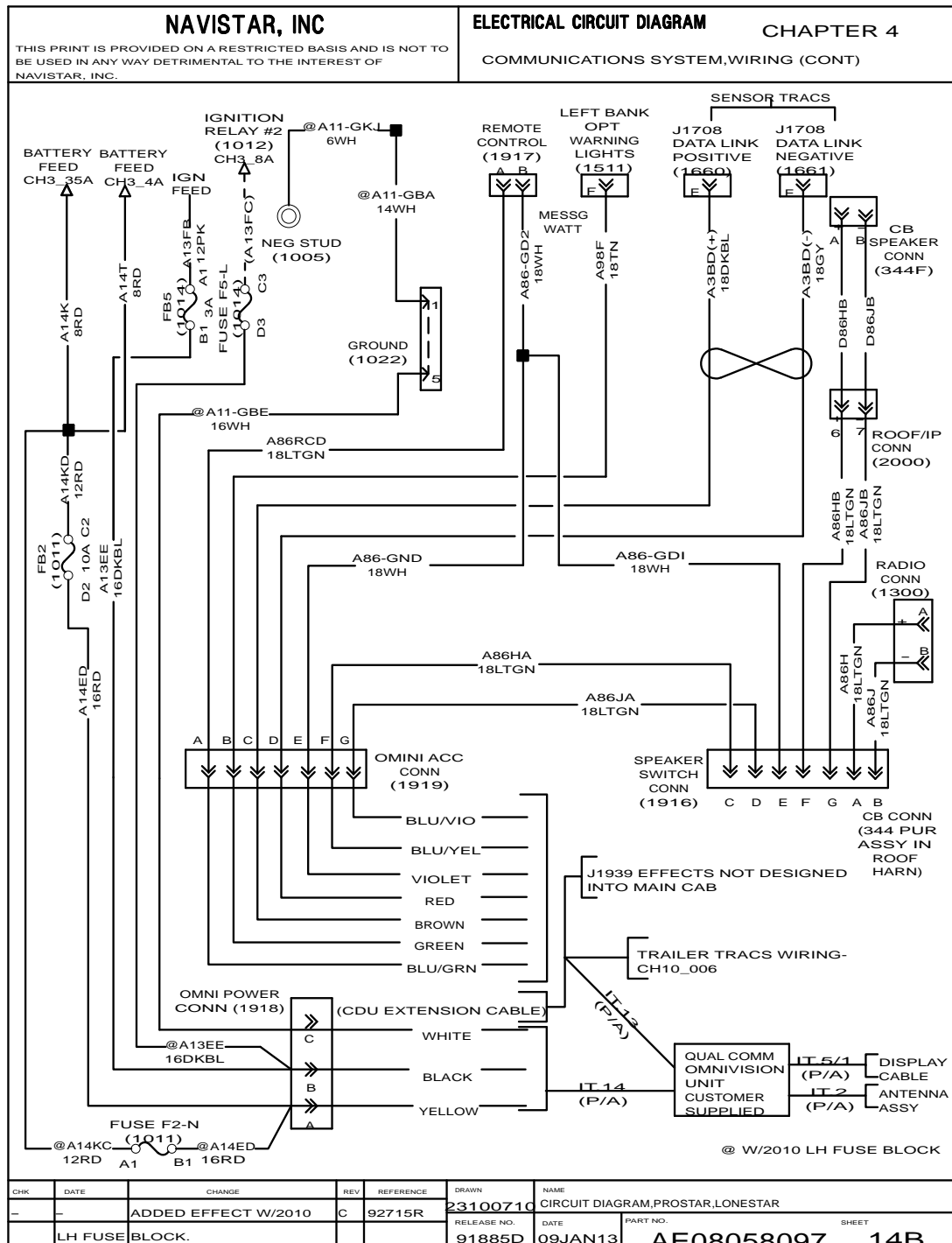

Figure 113 Communications System, Wiring (Cont.)

4.29. WINDSHIELD WIPER MOTOR, P. 21

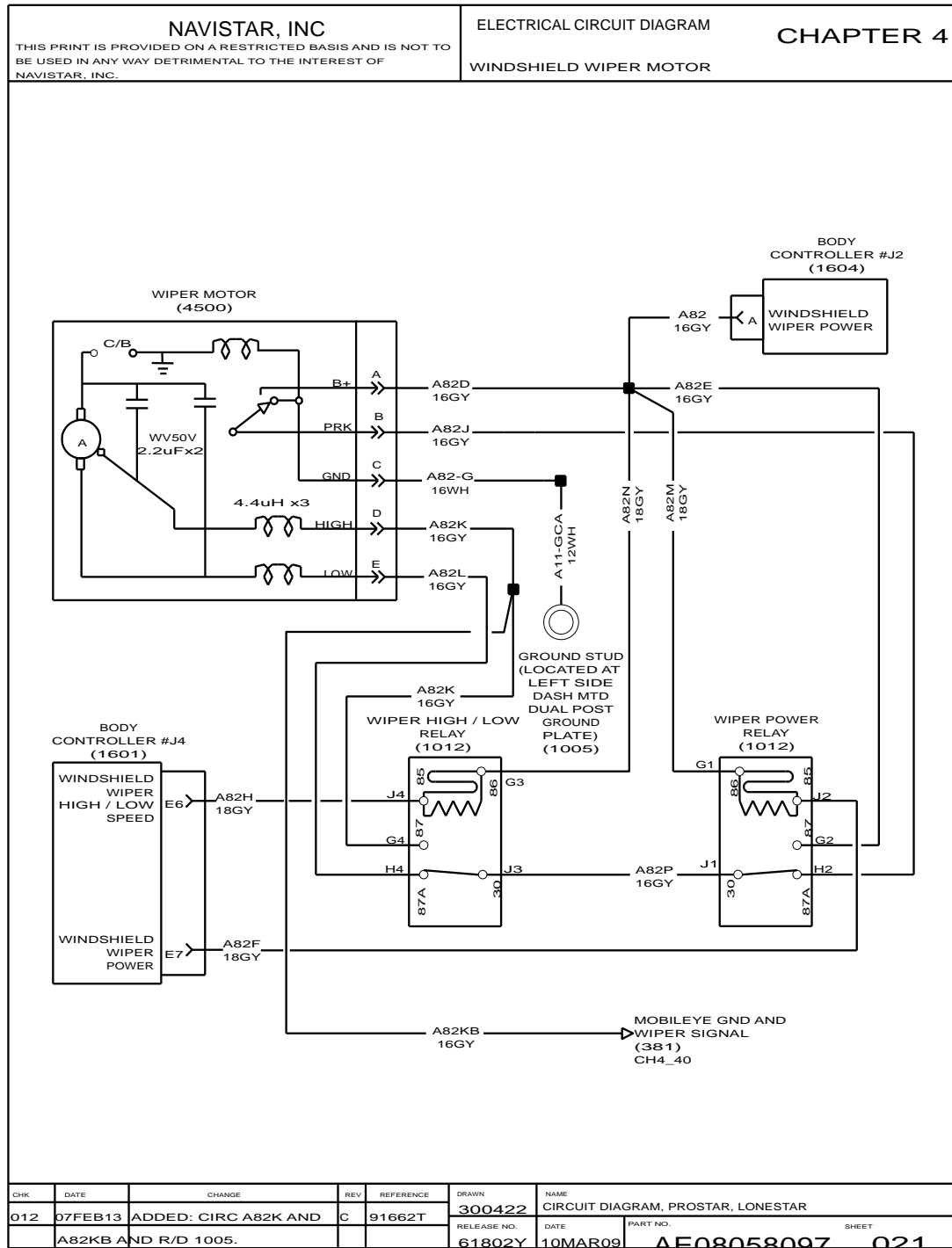

Figure 123 Windshield Wiper Motor

4.39. SPARE SWITCH – FOR DUAL CUSTOMER ACCESSORY, P. 27

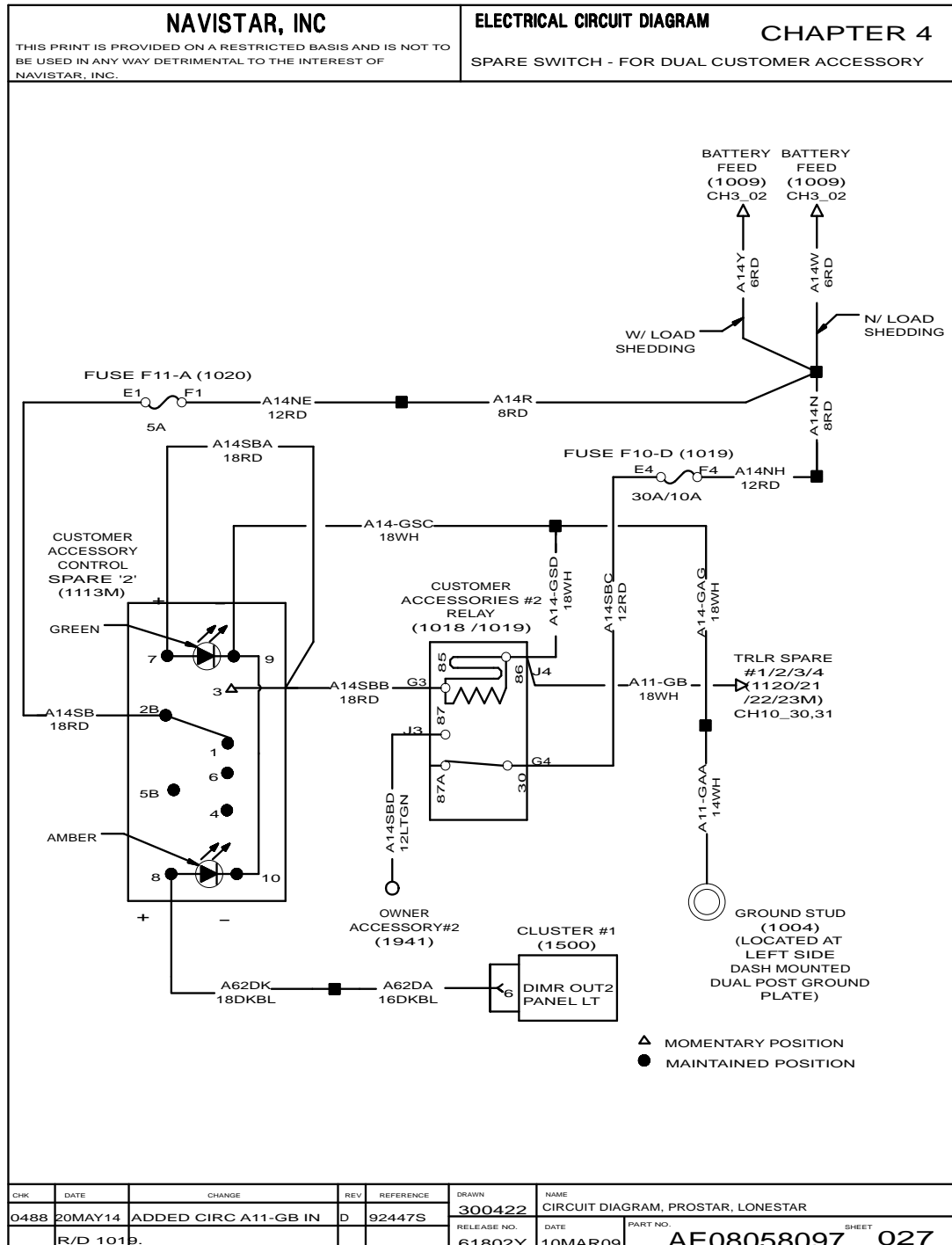

Figure 133 Spare Switch – for Dual Customer Accessory

4.59. SART CLOCK MODULE, P. 34

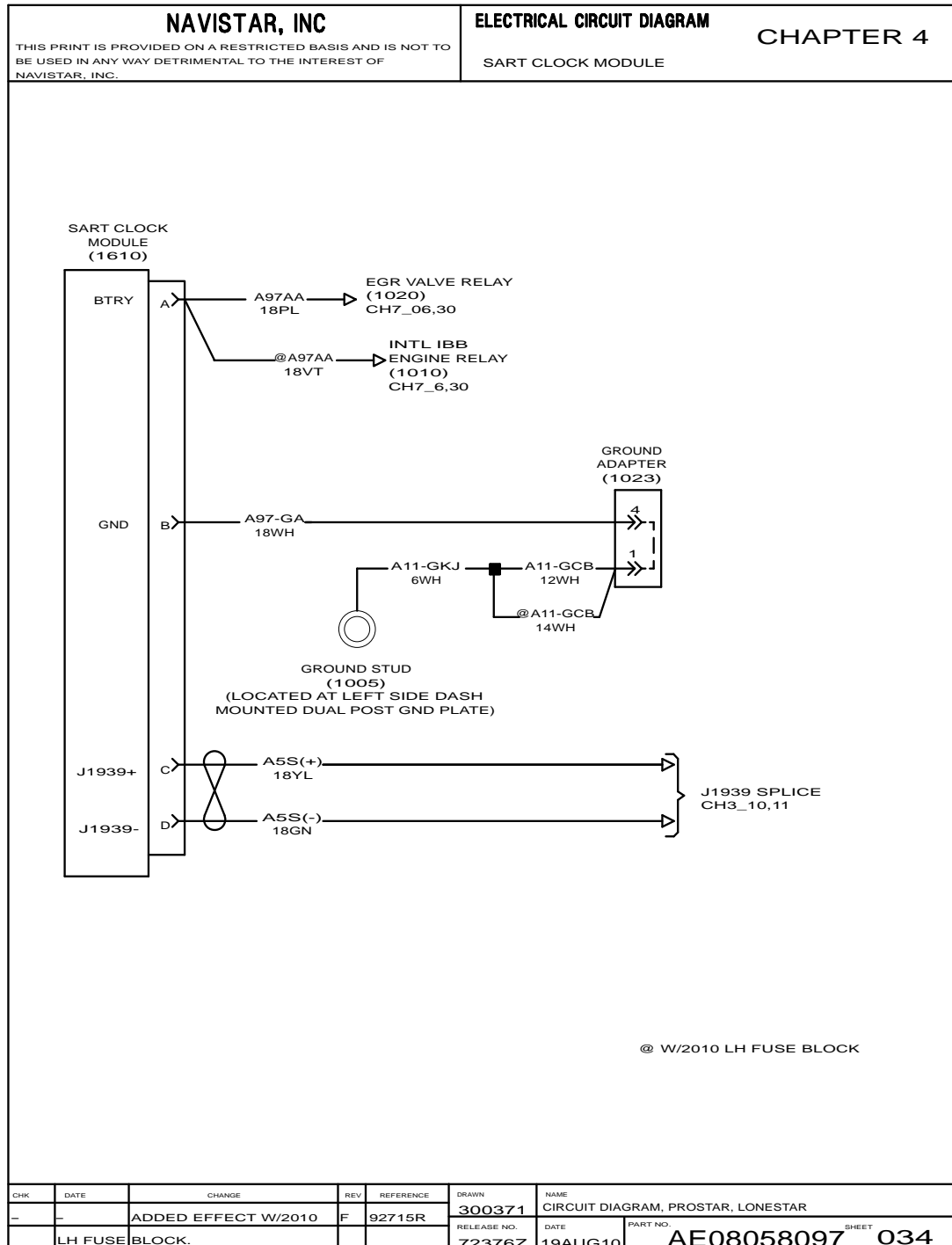

Figure 153 SART Clock Module

4.69. INTENTIONALLY LEFT BLANK, P. 44

NAVISTAR, INC <small>THIS PRINT IS PROVIDED ON A RESTRICTED BASIS AND IS NOT TO BE USED IN ANY WAY DETRIMENTAL TO THE INTEREST OF NAVISTAR, INC.</small>				ELECTRICAL CIRCUIT DIAGRAM INTENTIONALLY LEFT BLANK		CHAPTER 4	
<h1 style="margin: 0;">INTENTIONALLY LEFT BLANK</h1>							
CHK	DATE	CHANGE	REV	REFERENCE	DRAWN	NAME	
0610	12NOV13	GEOMETRY REMOVE.	B	90656P	MJV0088	CIRCUIT DIAGRAM, PORSTAR, LONESTAR	
					RELEASE NO.	DATE	PART NO. SHEET
					92050H	30MAY13	AE08058097 044

Figure 163 Intentionally Left Blank

4.79. ROLLTEK SEAT WIRING, P. 54

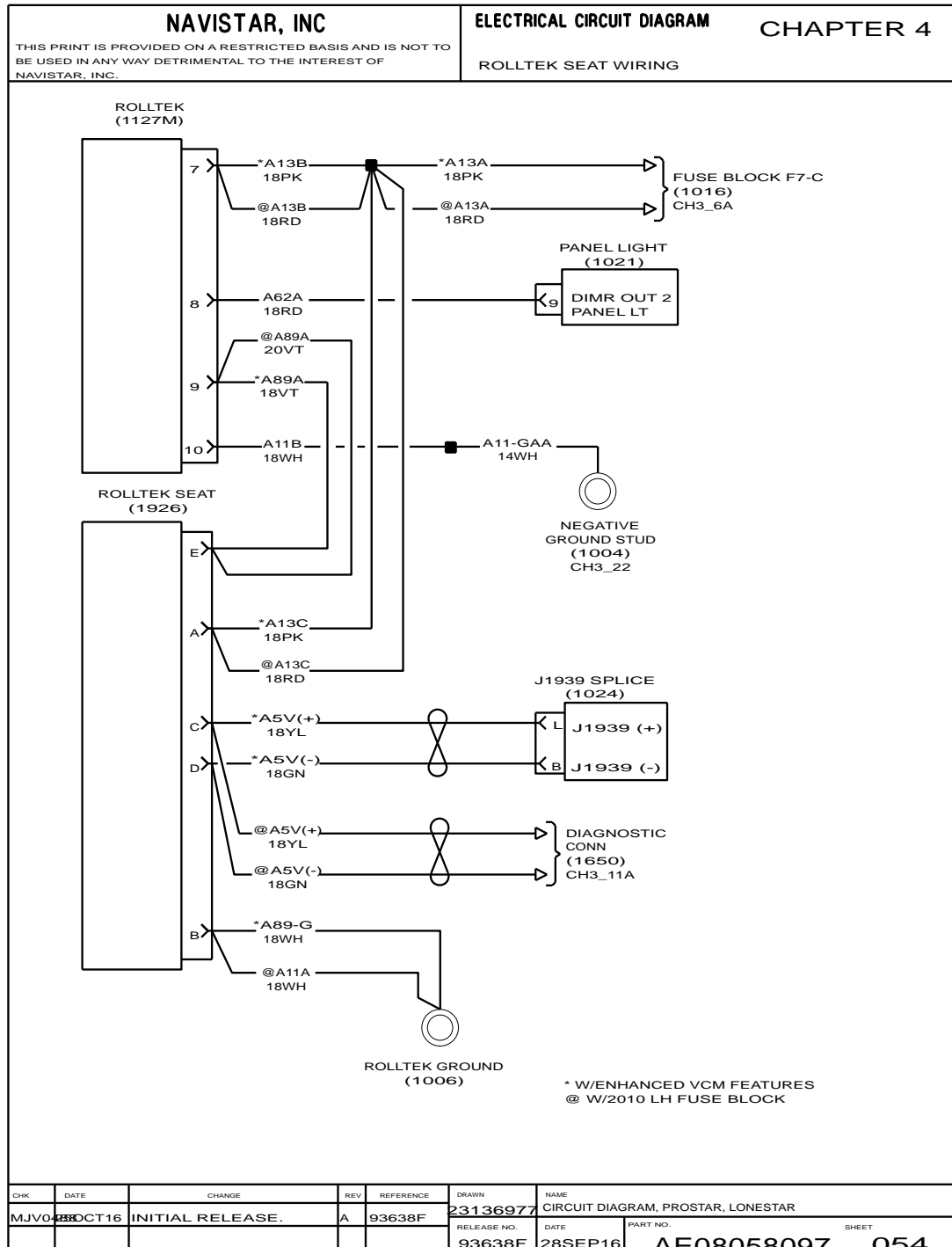

Figure 173 Rolltek Seat Wiring

ENGINES (CHAPTER 7)

7.1. ELECTRONIC ENGINE CONTROLS (2010 IBB ENGINE), P. 1

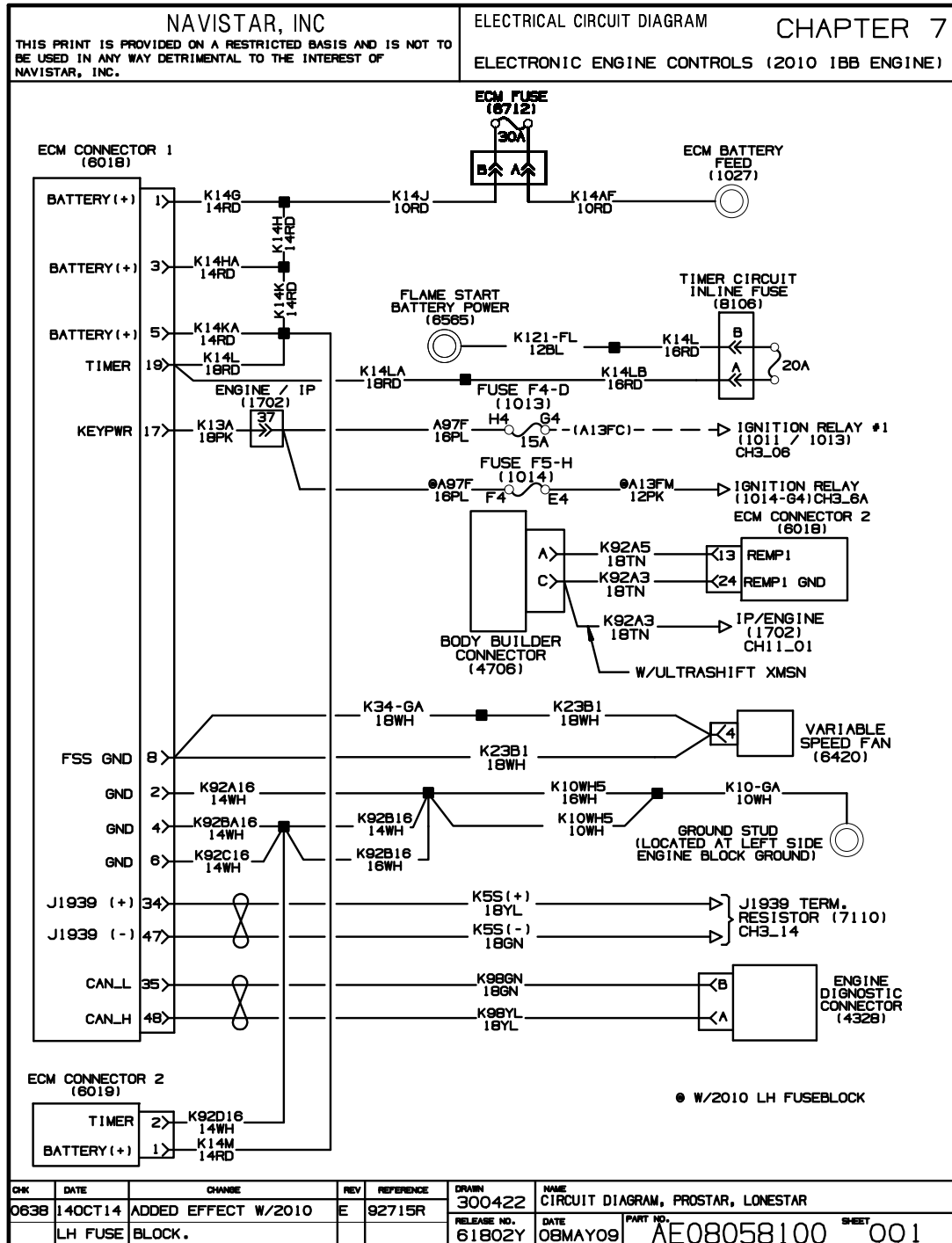

Figure 183 Electronic Engine Controls (2010 IBB Engine)

7.11. ELECTRONIC ENGINE CONTROLS – MAXXFORCE 15 LITRE (CONT.), P. 6E

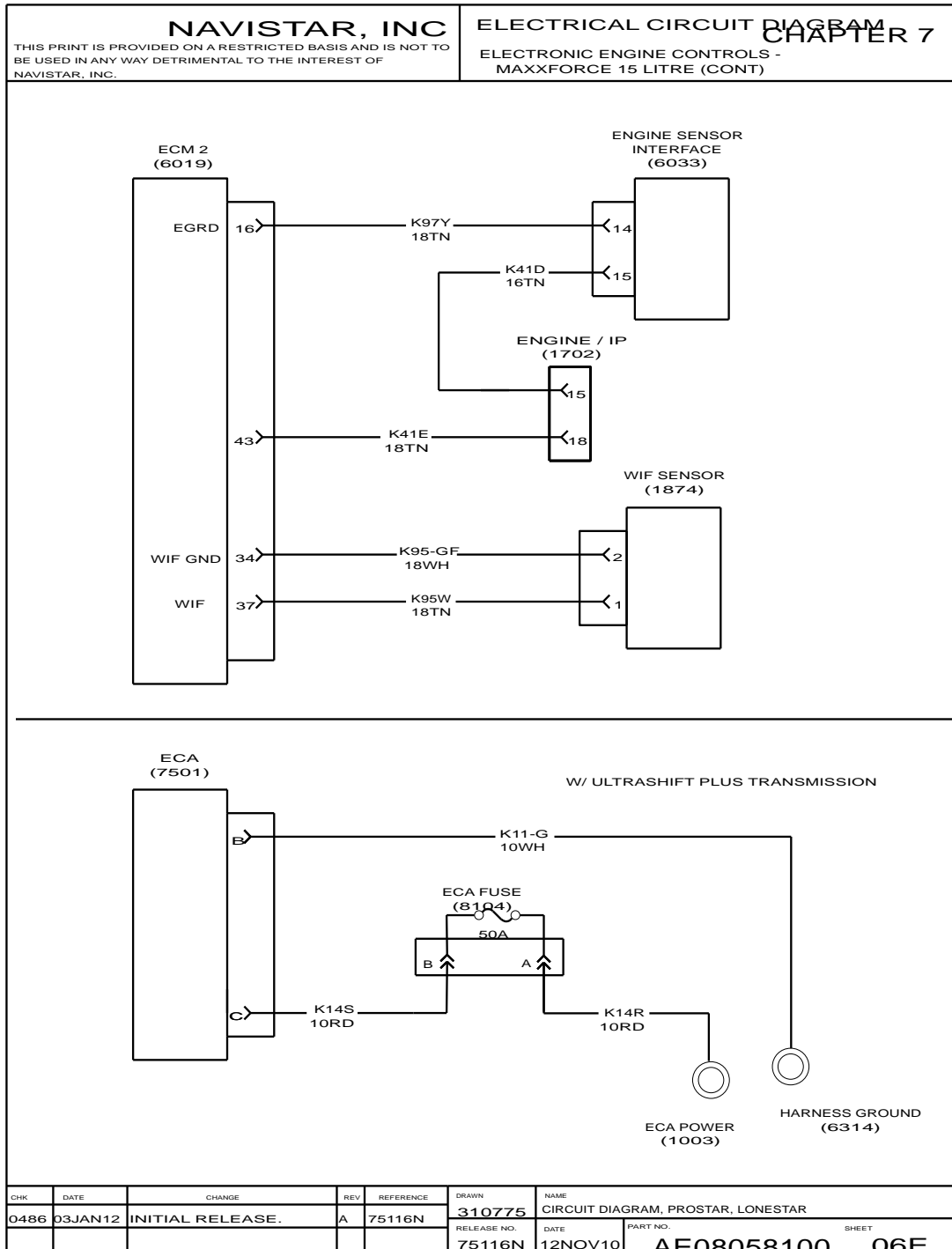

Figure 193 Electronic Engine Controls – MaxxForce 15 Litre (Cont.)

7.21. AUTO START / STOP (CONT.), P. 12A

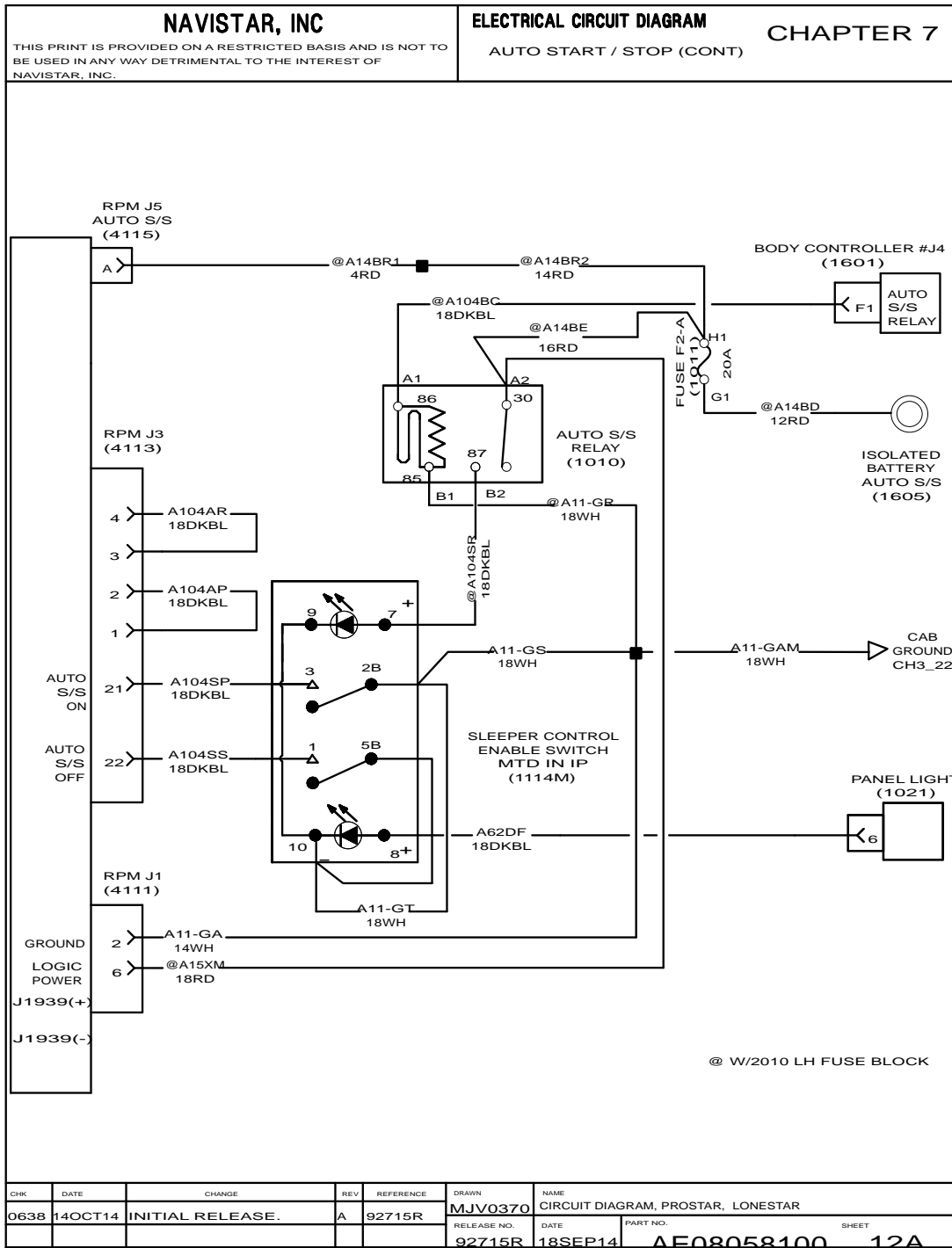

Figure 203 Auto Start / Stop (Cont.)

7.31. ISX 2013 DEF & AFTERTREATMENT (CONT.), P. 22

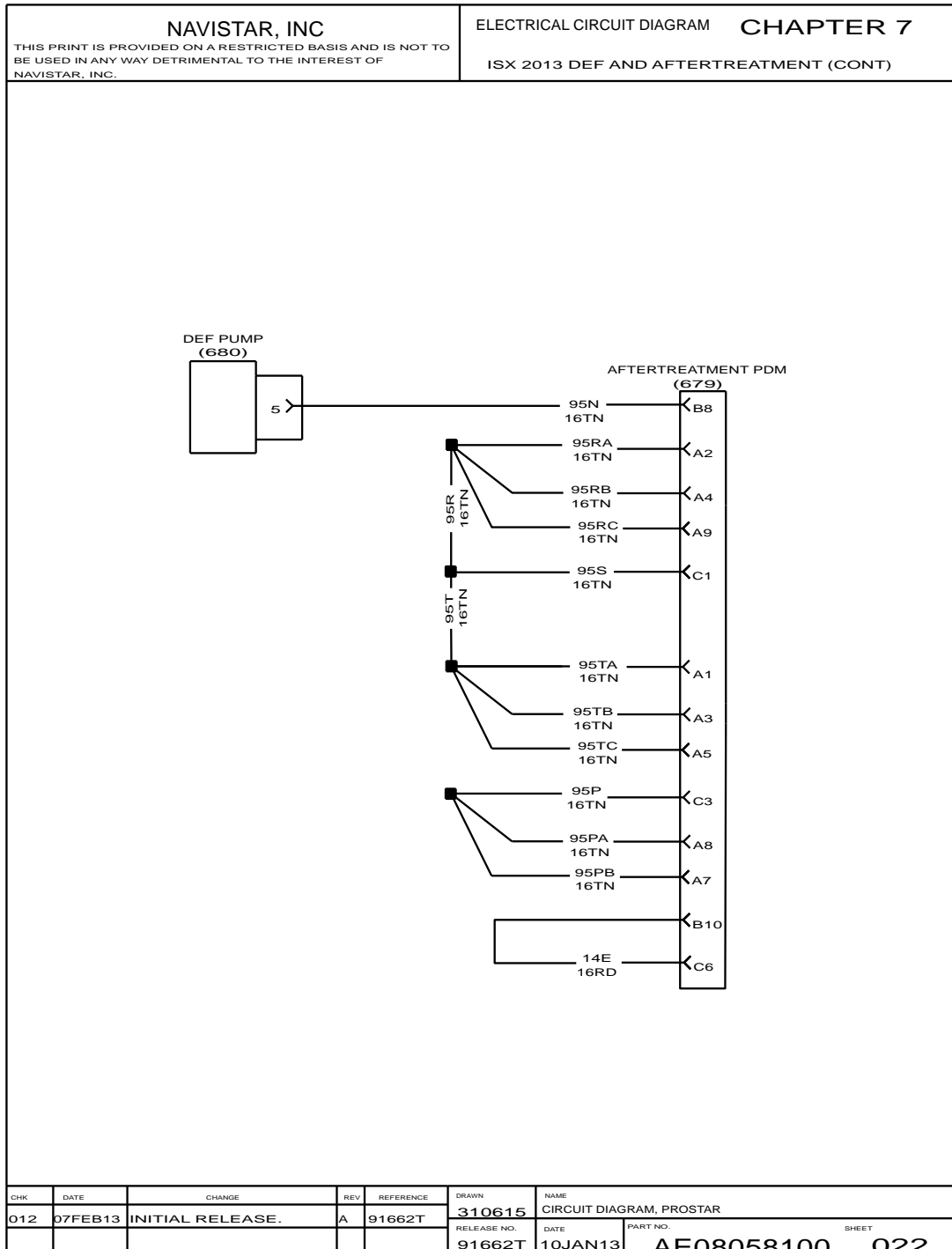

Figure 213 ISX 2013 DEF & Aftertreatment (Cont.)

7.41. DEF AND AFTERTREATMENT (2010 SCR 13L ENG) (CONT.), P. 32

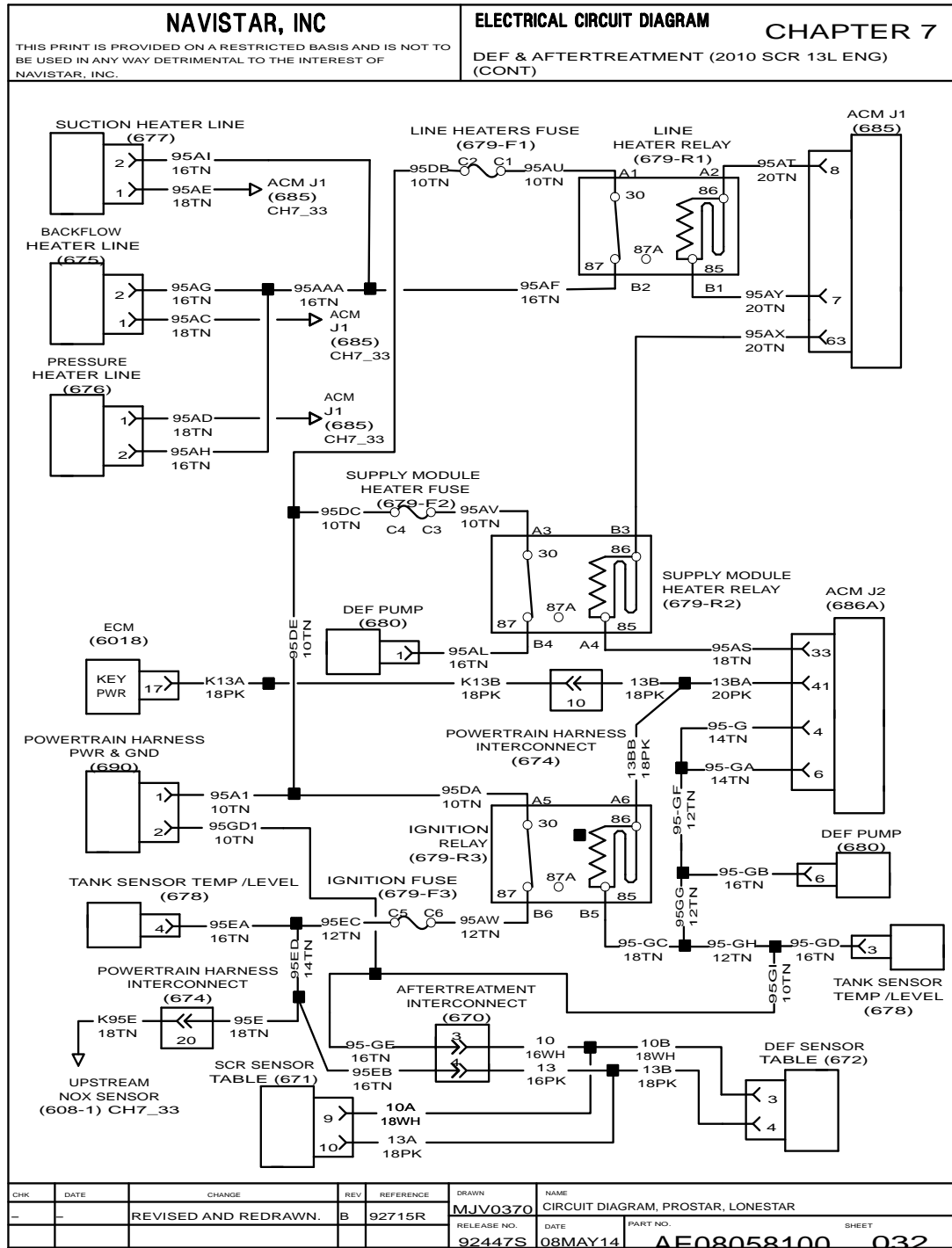

Figure 223 DEF and Aftertreatment (2010 SCR 13L ENG) (Cont.)

7.51. ELECTRONIC ENGINE CONTROLS (ISX 2013), P. 41

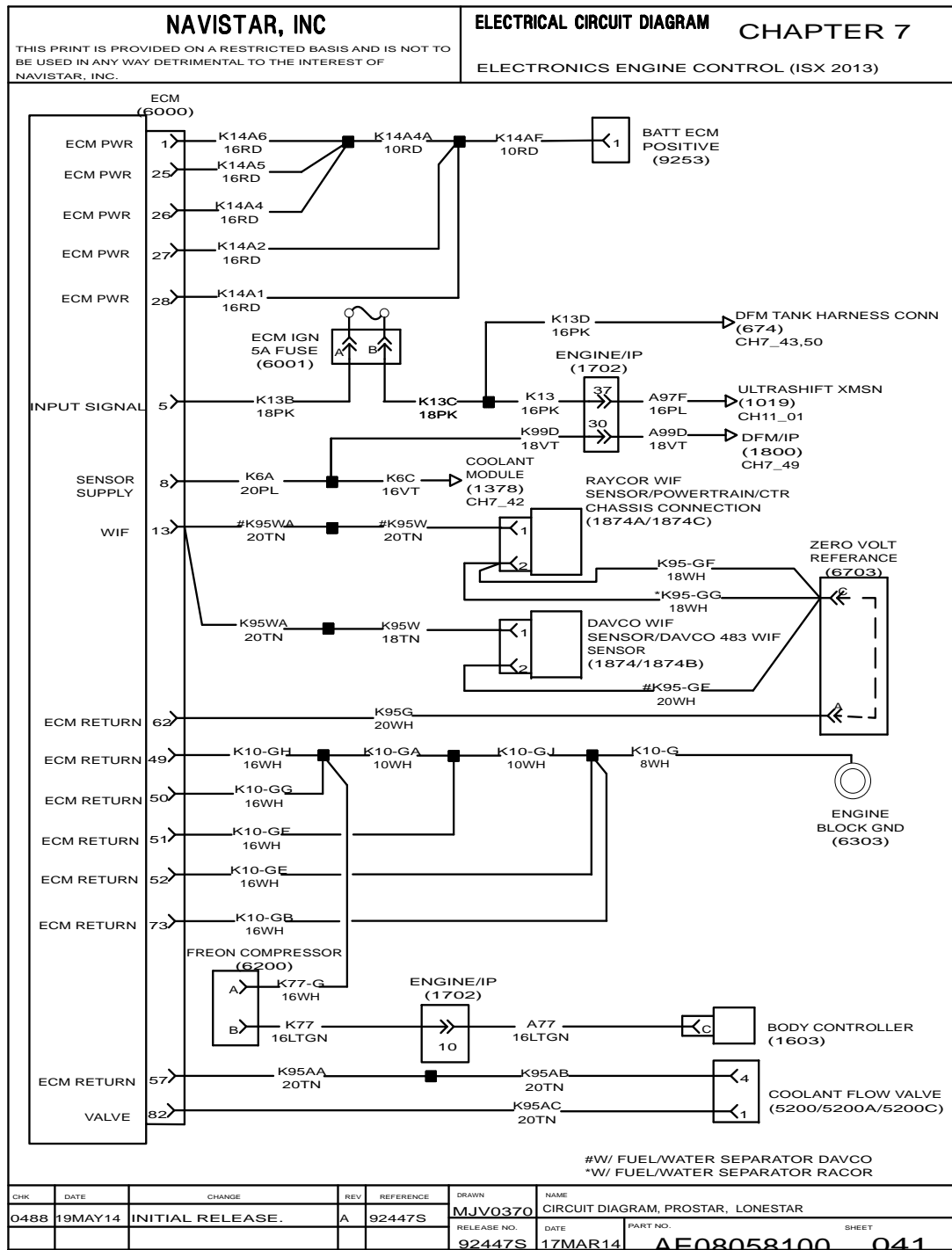

Figure 233 Electronic Engine Controls (ISX 2013)

7.61. DEF AND AFTERTREATMENT (ISX 2013) (CONT.), P. 51

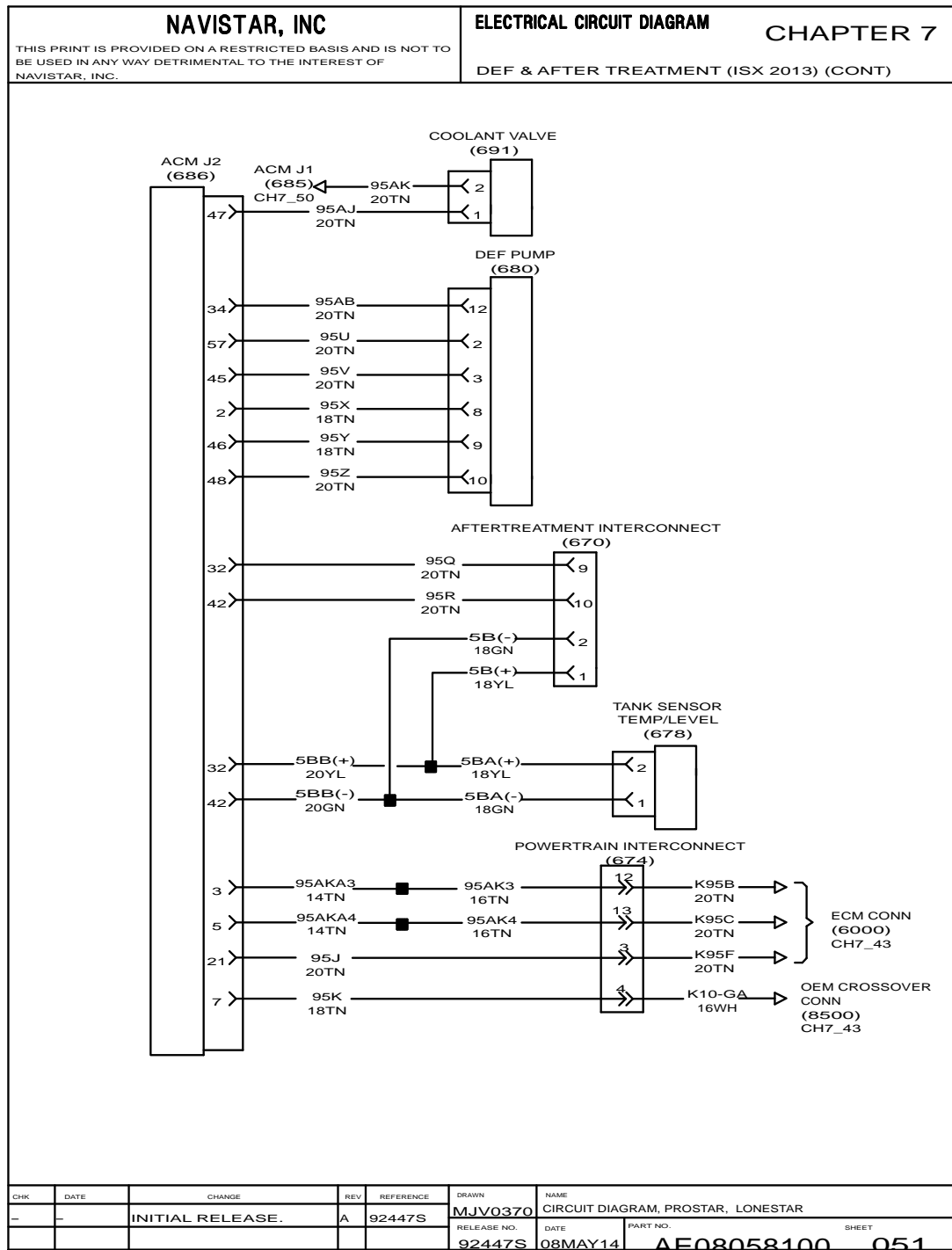

Figure 243 DEF and Aftertreatment (ISX 2013) (Cont.)

8.10. IP / GAUGES, P. 9

NAVISTAR, INC				ELECTRICAL CIRCUIT DIAGRAM CHAPTER 8																																																																											
THIS PRINT IS PROVIDED ON A RESTRICTED BASIS AND IS NOT TO BE USED IN ANY WAY DETRIMENTAL TO THE INTEREST OF NAVISTAR, INC.				IP / GAUGES																																																																											
<table border="1" style="width: 100%; border-collapse: collapse;"> <thead> <tr> <th colspan="4" style="text-align: center;">INSTRUMENT PANEL GAUGE CLUSTER</th> </tr> <tr> <th style="width: 25%;">GAUGE</th> <th style="width: 10%;">WARN LIGHT</th> <th style="width: 45%;">SIGNAL PATH</th> <th style="width: 20%;">SENSOR LOCATION</th> </tr> </thead> <tbody> <tr> <td>RPM (TACH)</td> <td style="text-align: center;">NO</td> <td>ENGINE CONT / DRIVE TRAIN J1939 / CLUSTER</td> <td>ENGINE</td> </tr> <tr> <td>MPH/KPH (SPD)</td> <td style="text-align: center;">NO</td> <td>ENGINE CONT / DRIVE TRAIN J1939 / CLUSTER</td> <td>TRANSMISSION</td> </tr> <tr> <td>FUEL</td> <td style="text-align: center;">YES</td> <td>BODY CONT / DRIVE TRAIN J1939 / CLUSTER</td> <td>FUEL TANK</td> </tr> <tr> <td>VOLT</td> <td style="text-align: center;">YES</td> <td>BODY CONT / DRIVE TRAIN J1939 / CLUSTER</td> <td>-</td> </tr> <tr> <td>AIR 1 (PRES)</td> <td style="text-align: center;">YES</td> <td>BODY CONT / DRIVE TRAIN J1939 / CLUSTER</td> <td>DRIVER CONTROL MODULE</td> </tr> <tr> <td>AIR 2 (PRES)</td> <td style="text-align: center;">YES</td> <td>BODY CONT / DRIVE TRAIN J1939 / CLUSTER</td> <td>DRIVER CONTROL MODULE</td> </tr> <tr> <td>WATER (TEMP)</td> <td style="text-align: center;">YES</td> <td>ENGINE CONT / DRIVE TRAIN J1939 / CLUSTER</td> <td>ENGINE</td> </tr> <tr> <td>ENG OIL (TEMP)</td> <td style="text-align: center;">YES</td> <td>ENGINE CONT / DRIVE TRAIN J1939 / CLUSTER</td> <td>ENGINE</td> </tr> <tr> <td>OIL (PRES)</td> <td style="text-align: center;">YES</td> <td>ENGINE CONT / DRIVE TRAIN J1939 / CLUSTER</td> <td>ENGINE</td> </tr> <tr> <td>TRANS (TEMP)</td> <td style="text-align: center;">YES</td> <td>BODY CONT / DRIVE TRAIN J1939 / CLUSTER</td> <td>TRANSMISSION</td> </tr> </tbody> </table> <table border="1" style="width: 100%; border-collapse: collapse;"> <thead> <tr> <th colspan="4" style="text-align: center;">SECONDARY GAUGE CLUSTER</th> </tr> <tr> <th style="width: 25%;">GAUGE</th> <th style="width: 10%;">WARN LIGHT</th> <th style="width: 45%;">SIGNAL PATH</th> <th style="width: 20%;">SENSOR LOCATION</th> </tr> </thead> <tbody> <tr> <td>REAR RR AXLE OIL TEMP</td> <td style="text-align: center;">YES</td> <td>BODY CONT / DRIVE TRAIN J1939 / CLUSTER</td> <td>REAR RR AXLE</td> </tr> <tr> <td>FORWARD RR AXLE OIL TEMP</td> <td style="text-align: center;">YES</td> <td>BODY CONT / DRIVE TRAIN J1939 / CLUSTER</td> <td>FORWARD RR AXLE</td> </tr> <tr> <td>BOOST PRESSURE</td> <td style="text-align: center;">NO</td> <td>ENGINE CONT / DRIVE TRAIN J1939 / CLUSTER</td> <td>ENGINE</td> </tr> <tr> <td>AIR APPLICATION</td> <td style="text-align: center;">NO</td> <td>BODY CONT / DRIVE TRAIN J1939 / CLUSTER</td> <td>DRIVER CONTROL MODULE</td> </tr> </tbody> </table> <p style="margin-top: 20px;">NOTES: 1. WARNING LIGHTS ARE PART OF THE GAUGES AND LOCATED IN THE GAUGE CLUSTER</p>								INSTRUMENT PANEL GAUGE CLUSTER				GAUGE	WARN LIGHT	SIGNAL PATH	SENSOR LOCATION	RPM (TACH)	NO	ENGINE CONT / DRIVE TRAIN J1939 / CLUSTER	ENGINE	MPH/KPH (SPD)	NO	ENGINE CONT / DRIVE TRAIN J1939 / CLUSTER	TRANSMISSION	FUEL	YES	BODY CONT / DRIVE TRAIN J1939 / CLUSTER	FUEL TANK	VOLT	YES	BODY CONT / DRIVE TRAIN J1939 / CLUSTER	-	AIR 1 (PRES)	YES	BODY CONT / DRIVE TRAIN J1939 / CLUSTER	DRIVER CONTROL MODULE	AIR 2 (PRES)	YES	BODY CONT / DRIVE TRAIN J1939 / CLUSTER	DRIVER CONTROL MODULE	WATER (TEMP)	YES	ENGINE CONT / DRIVE TRAIN J1939 / CLUSTER	ENGINE	ENG OIL (TEMP)	YES	ENGINE CONT / DRIVE TRAIN J1939 / CLUSTER	ENGINE	OIL (PRES)	YES	ENGINE CONT / DRIVE TRAIN J1939 / CLUSTER	ENGINE	TRANS (TEMP)	YES	BODY CONT / DRIVE TRAIN J1939 / CLUSTER	TRANSMISSION	SECONDARY GAUGE CLUSTER				GAUGE	WARN LIGHT	SIGNAL PATH	SENSOR LOCATION	REAR RR AXLE OIL TEMP	YES	BODY CONT / DRIVE TRAIN J1939 / CLUSTER	REAR RR AXLE	FORWARD RR AXLE OIL TEMP	YES	BODY CONT / DRIVE TRAIN J1939 / CLUSTER	FORWARD RR AXLE	BOOST PRESSURE	NO	ENGINE CONT / DRIVE TRAIN J1939 / CLUSTER	ENGINE	AIR APPLICATION	NO	BODY CONT / DRIVE TRAIN J1939 / CLUSTER	DRIVER CONTROL MODULE
INSTRUMENT PANEL GAUGE CLUSTER																																																																															
GAUGE	WARN LIGHT	SIGNAL PATH	SENSOR LOCATION																																																																												
RPM (TACH)	NO	ENGINE CONT / DRIVE TRAIN J1939 / CLUSTER	ENGINE																																																																												
MPH/KPH (SPD)	NO	ENGINE CONT / DRIVE TRAIN J1939 / CLUSTER	TRANSMISSION																																																																												
FUEL	YES	BODY CONT / DRIVE TRAIN J1939 / CLUSTER	FUEL TANK																																																																												
VOLT	YES	BODY CONT / DRIVE TRAIN J1939 / CLUSTER	-																																																																												
AIR 1 (PRES)	YES	BODY CONT / DRIVE TRAIN J1939 / CLUSTER	DRIVER CONTROL MODULE																																																																												
AIR 2 (PRES)	YES	BODY CONT / DRIVE TRAIN J1939 / CLUSTER	DRIVER CONTROL MODULE																																																																												
WATER (TEMP)	YES	ENGINE CONT / DRIVE TRAIN J1939 / CLUSTER	ENGINE																																																																												
ENG OIL (TEMP)	YES	ENGINE CONT / DRIVE TRAIN J1939 / CLUSTER	ENGINE																																																																												
OIL (PRES)	YES	ENGINE CONT / DRIVE TRAIN J1939 / CLUSTER	ENGINE																																																																												
TRANS (TEMP)	YES	BODY CONT / DRIVE TRAIN J1939 / CLUSTER	TRANSMISSION																																																																												
SECONDARY GAUGE CLUSTER																																																																															
GAUGE	WARN LIGHT	SIGNAL PATH	SENSOR LOCATION																																																																												
REAR RR AXLE OIL TEMP	YES	BODY CONT / DRIVE TRAIN J1939 / CLUSTER	REAR RR AXLE																																																																												
FORWARD RR AXLE OIL TEMP	YES	BODY CONT / DRIVE TRAIN J1939 / CLUSTER	FORWARD RR AXLE																																																																												
BOOST PRESSURE	NO	ENGINE CONT / DRIVE TRAIN J1939 / CLUSTER	ENGINE																																																																												
AIR APPLICATION	NO	BODY CONT / DRIVE TRAIN J1939 / CLUSTER	DRIVER CONTROL MODULE																																																																												
CHK	DATE	CHANGE	REV	REFERENCE	DRAWN	NAME																																																																									
0486	30DEC11	TITLE WAS CIRCUIT	B	82357E	300422	CIRCUIT DIAGRAM, PROSTAR, LONESTAR																																																																									
	DIAGRAM, PROSTAR.				RELEASE NO.	DATE	PART NO.																																																																								
					61802Y	09MAR09	AE08058101 009																																																																								

Figure 253 IP / Gauges

9.5. STOP, TAIL, TURN AND BACK-UP WITH FREEDOMLINE LIGHTS, P. 2C

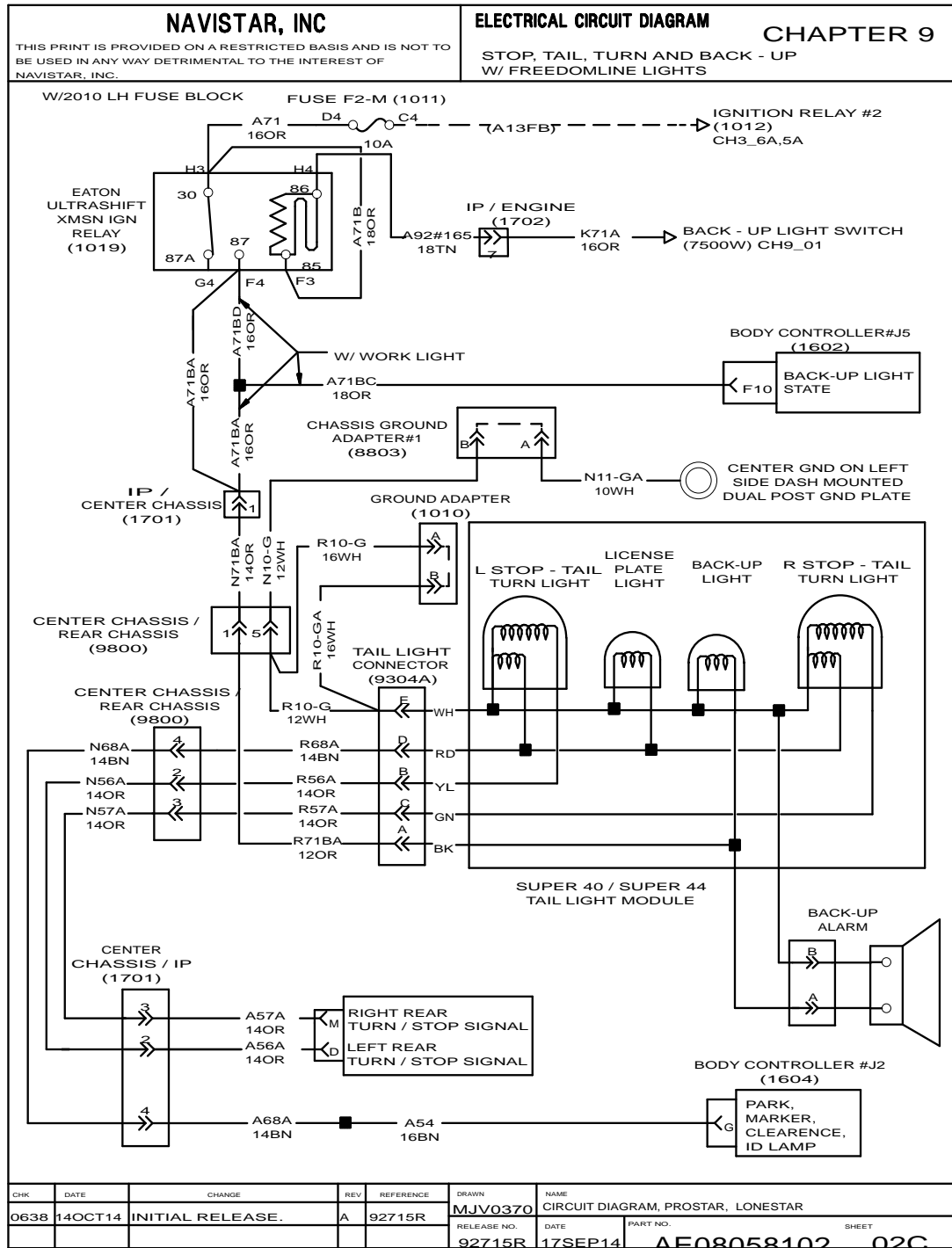

Figure 263 Stop, Tail, Turn and Back-up with FreedomLine Lights

9.15. LIGHT SYSTEM – PARK, MARKER, CLEARANCE, ID, TURN, STOP, TAIL, P. 9

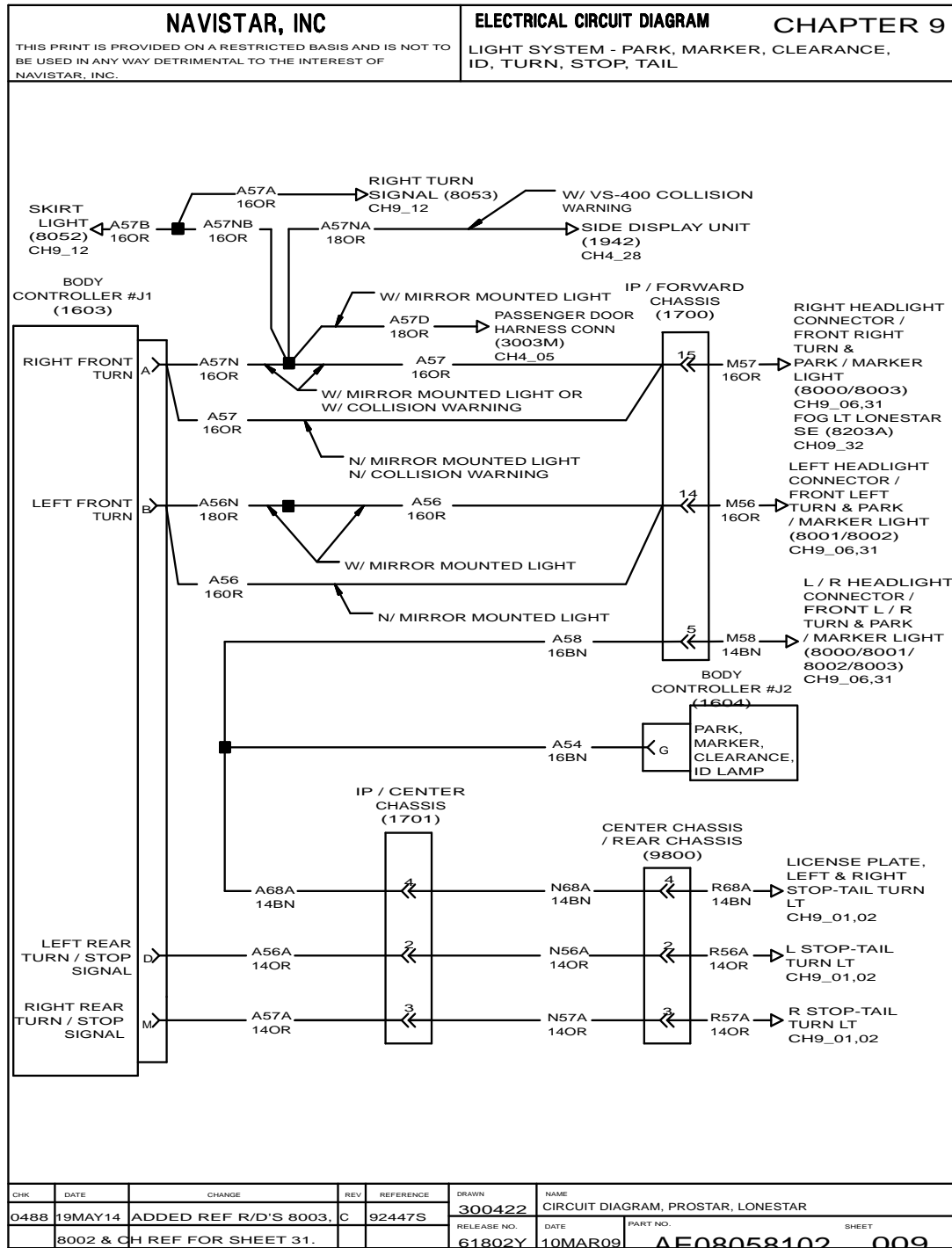

Figure 273 Light System – Park, Marker, Clearance, ID, Turn, Stop, Tail

9.25. TRAILER SOCKET – BACK OF CAB, P. 14

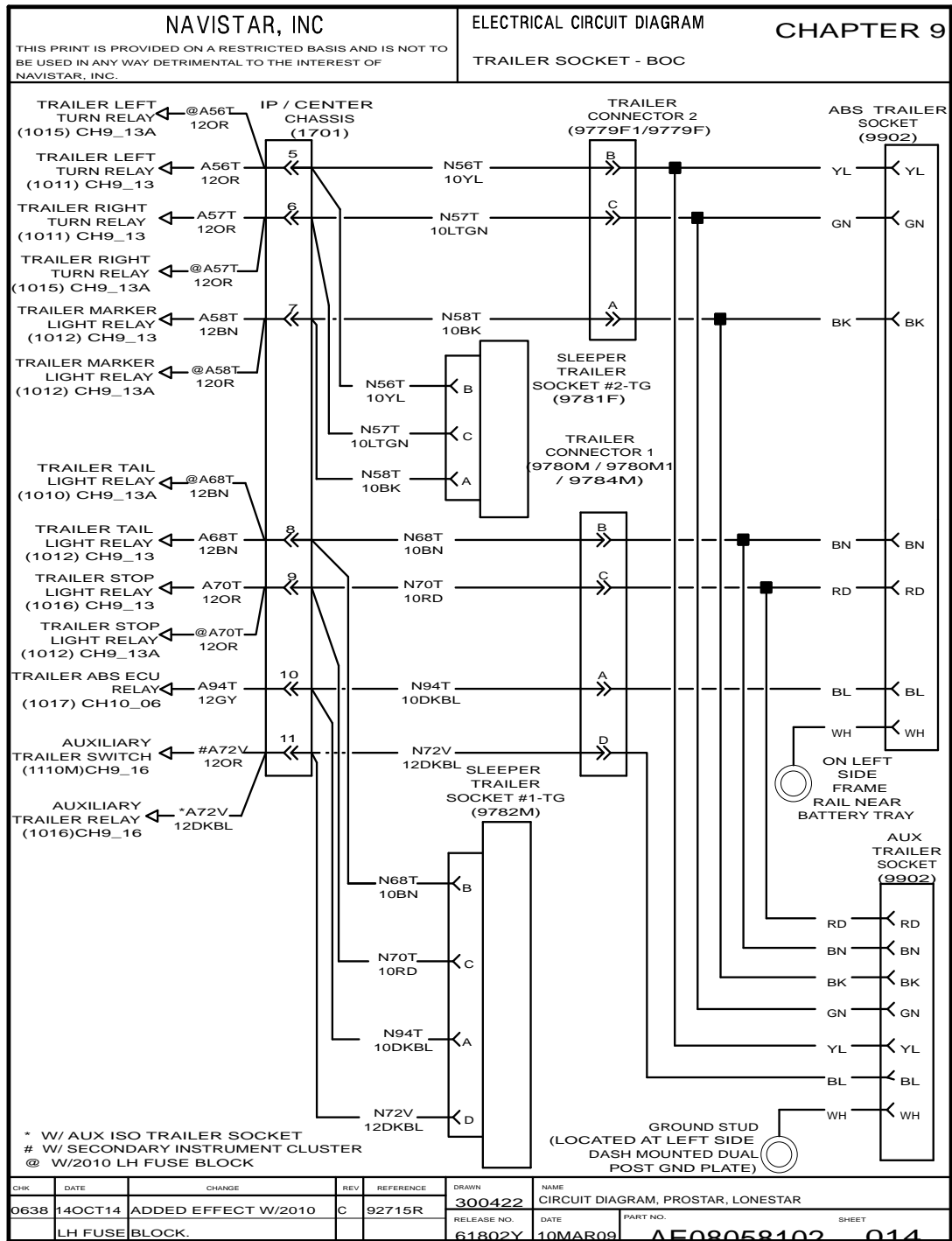

Figure 283 Trailer Socket – Back of Cab

9.35. FLOOR LIGHT, P. 17C

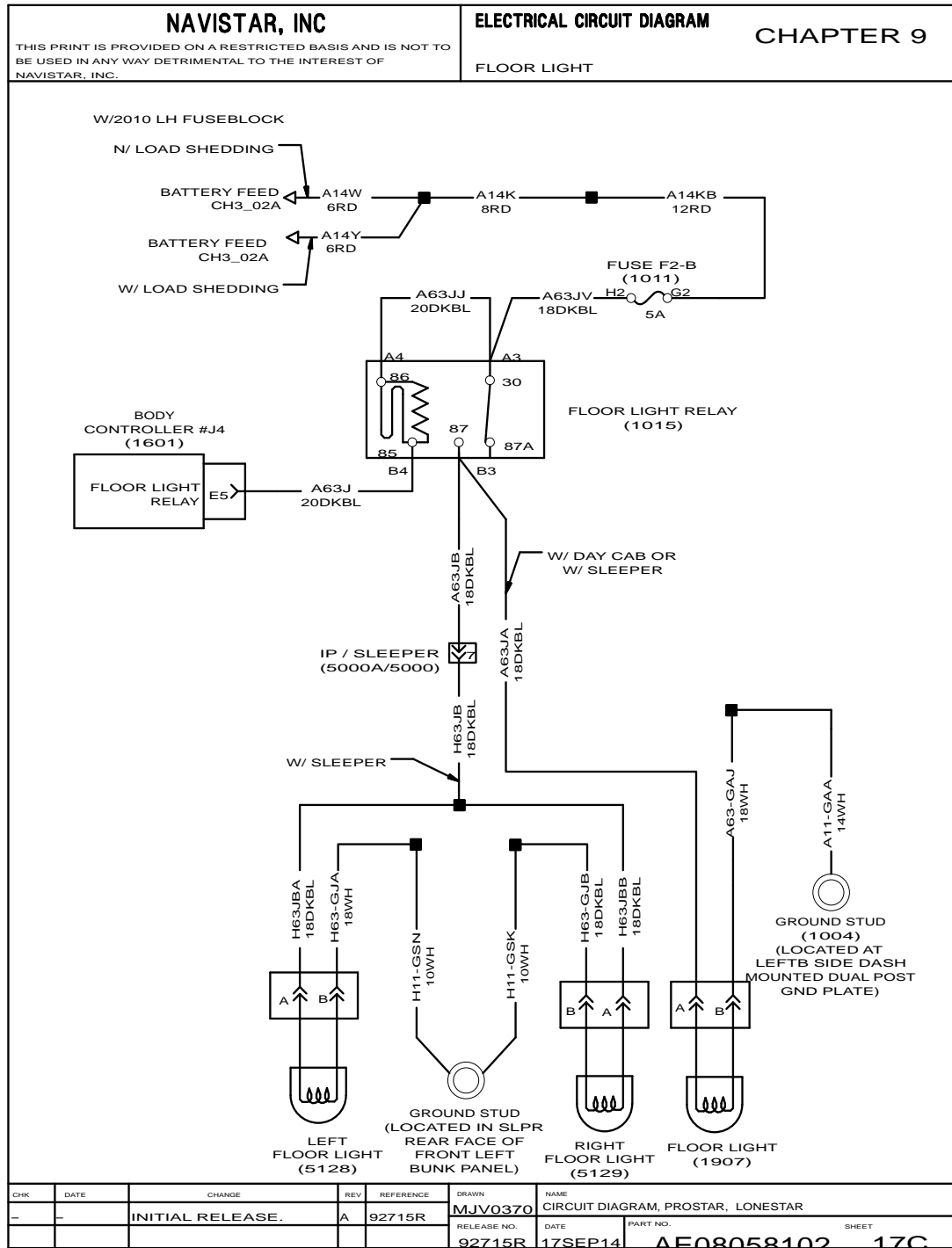

Figure 293 Floor Light

CLICK HERE TO **DOWNLOAD** THE COMPLETE MANUAL

- Thank you very much for reading the preview of the manual.
- You can download the complete manual from: www.heydownloads.com by clicking the link below



- Please note: If there is no response to CLICKING the link, please download this PDF first and then click on it.

CLICK HERE TO **DOWNLOAD** THE COMPLETE MANUAL

9.55. LIGHTS – STOP, TAIL, TURN AND BACK-UP (6 X 4) (CONT.), P. 34

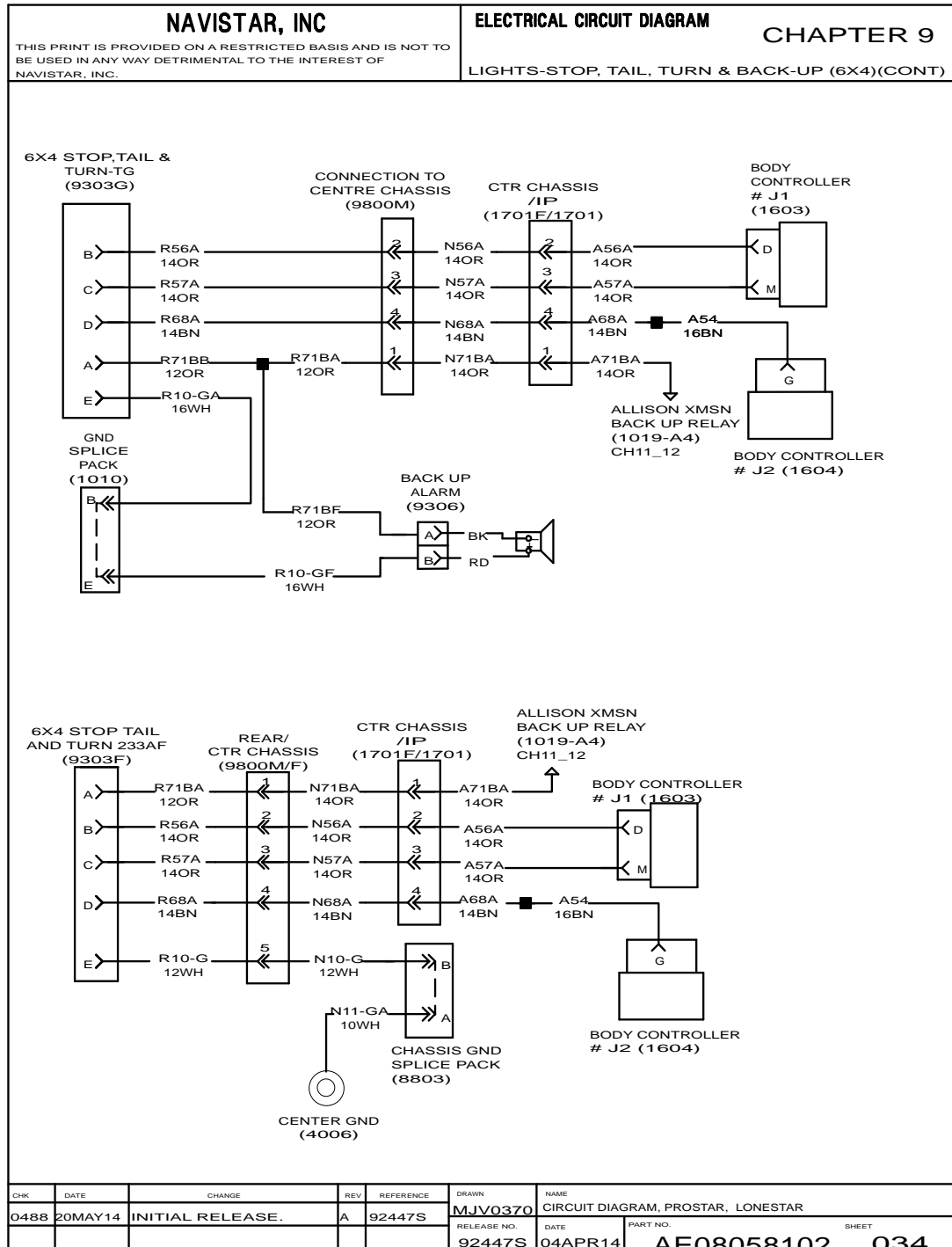
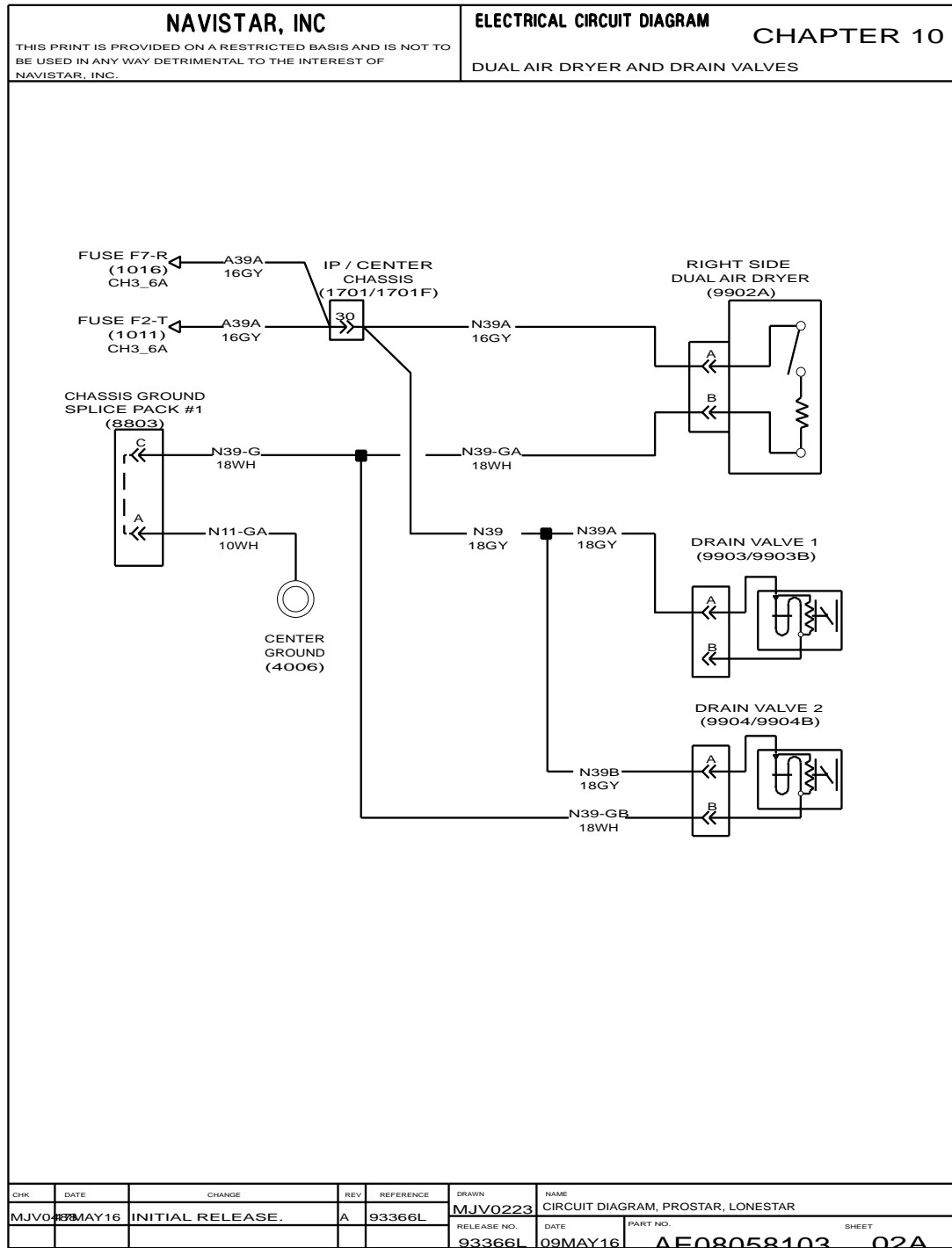

Figure 313 Lights – Stop, Tail, Turn and Back-Up (6 X 4) (Cont.)

10.3. DUAL AIR DRYER AND DRAIN VALVES, P. 2A



10.13. ANTILOCK BRAKE SYSTEM WITH BENDIX (CONT.), P. 10A

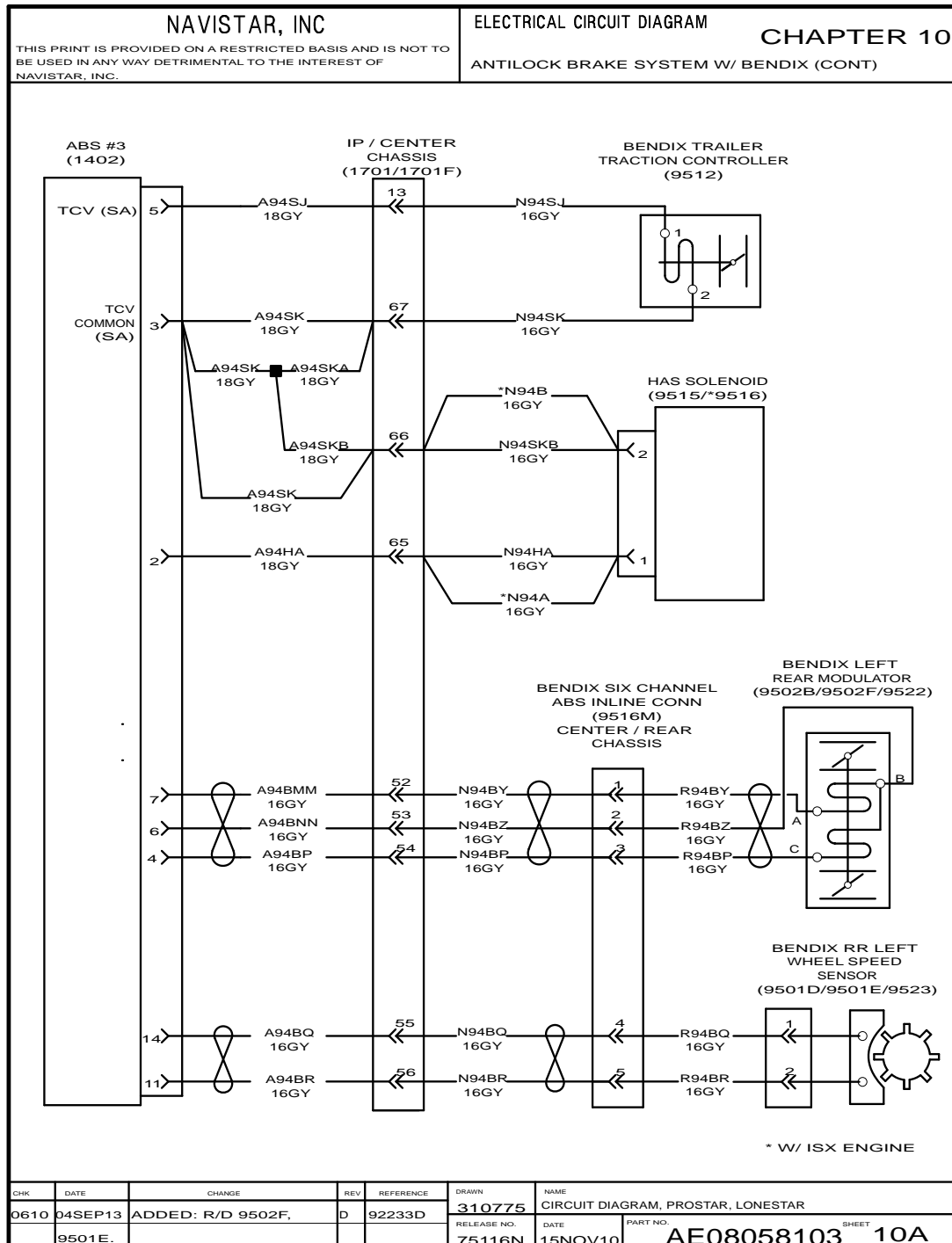

Figure 333 Antilock Brake System with Bendix (Cont.)

10.23. ANTILOCK BRAKE SYSTEM WITH WABCO (CONT.), P. 15A

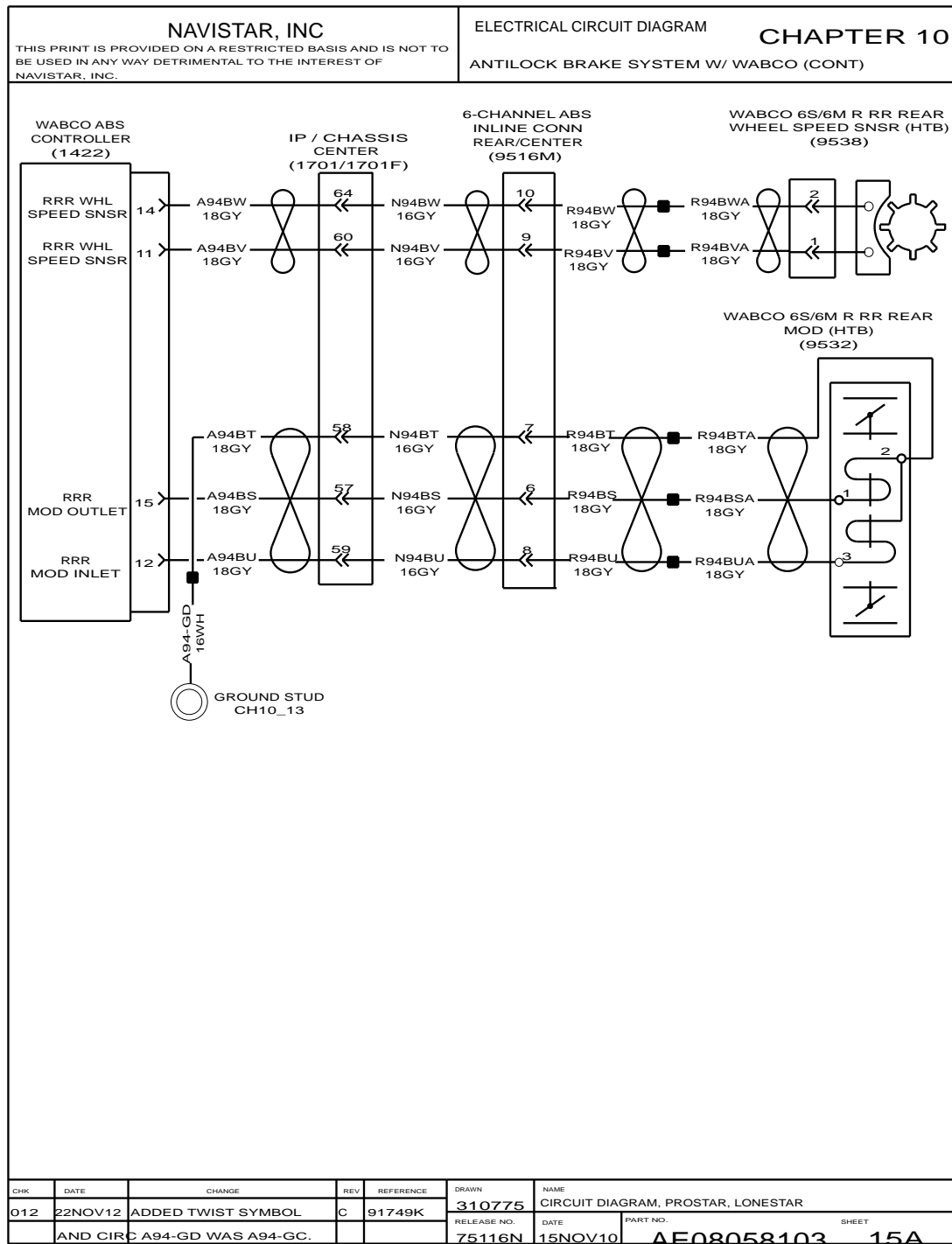

Figure 343 Antilock Brake System With WABCO (Cont.)

10.33. LIFT GATE POWER FEED, P. 22A

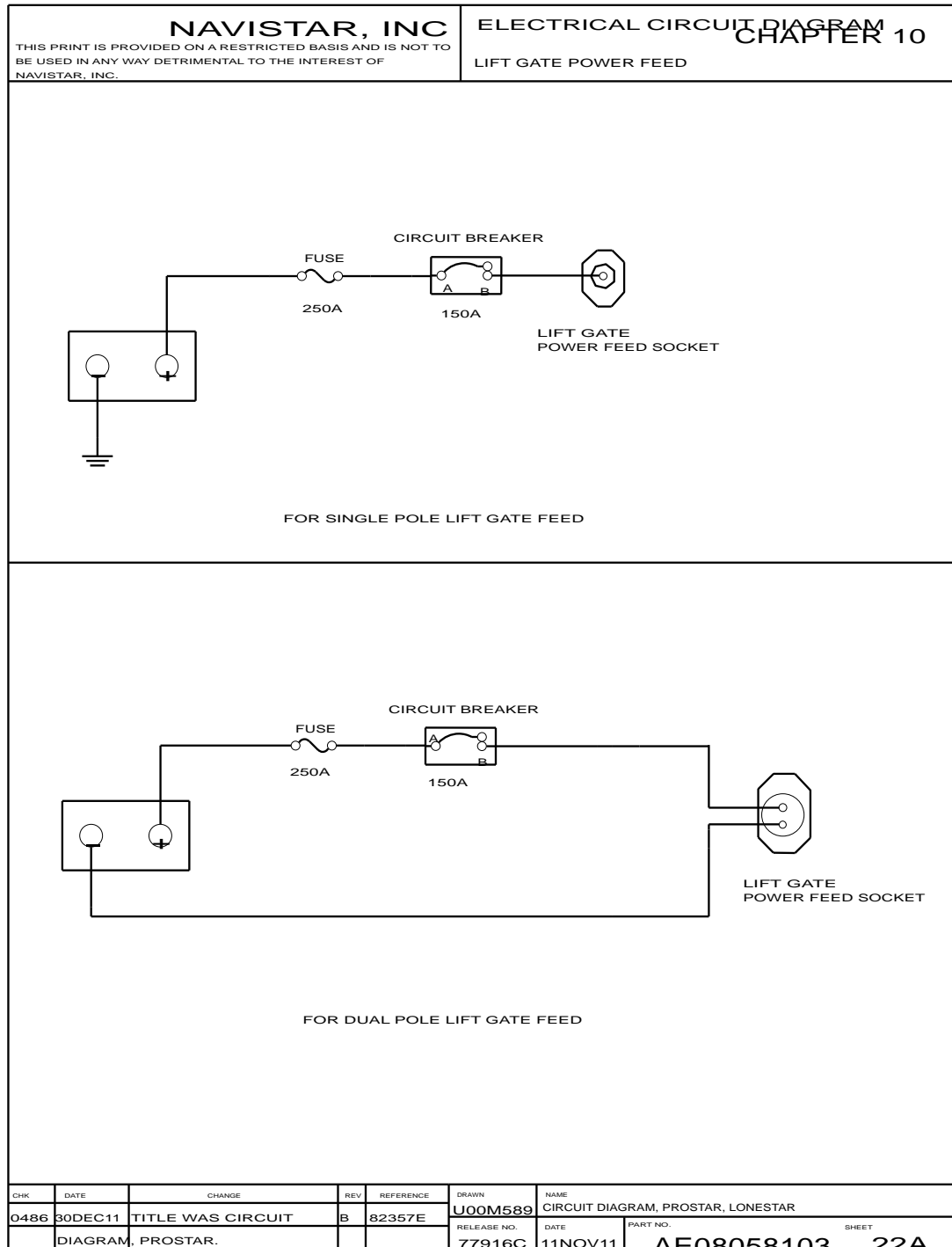

Figure 353 Lift Gate Power Feed

TRANSMISSION CONTROL MODULE (CHAPTER 11)

11.1. EATON AUTOSHIFT AND ULTRASHIFT TRANSMISSION, P. 1

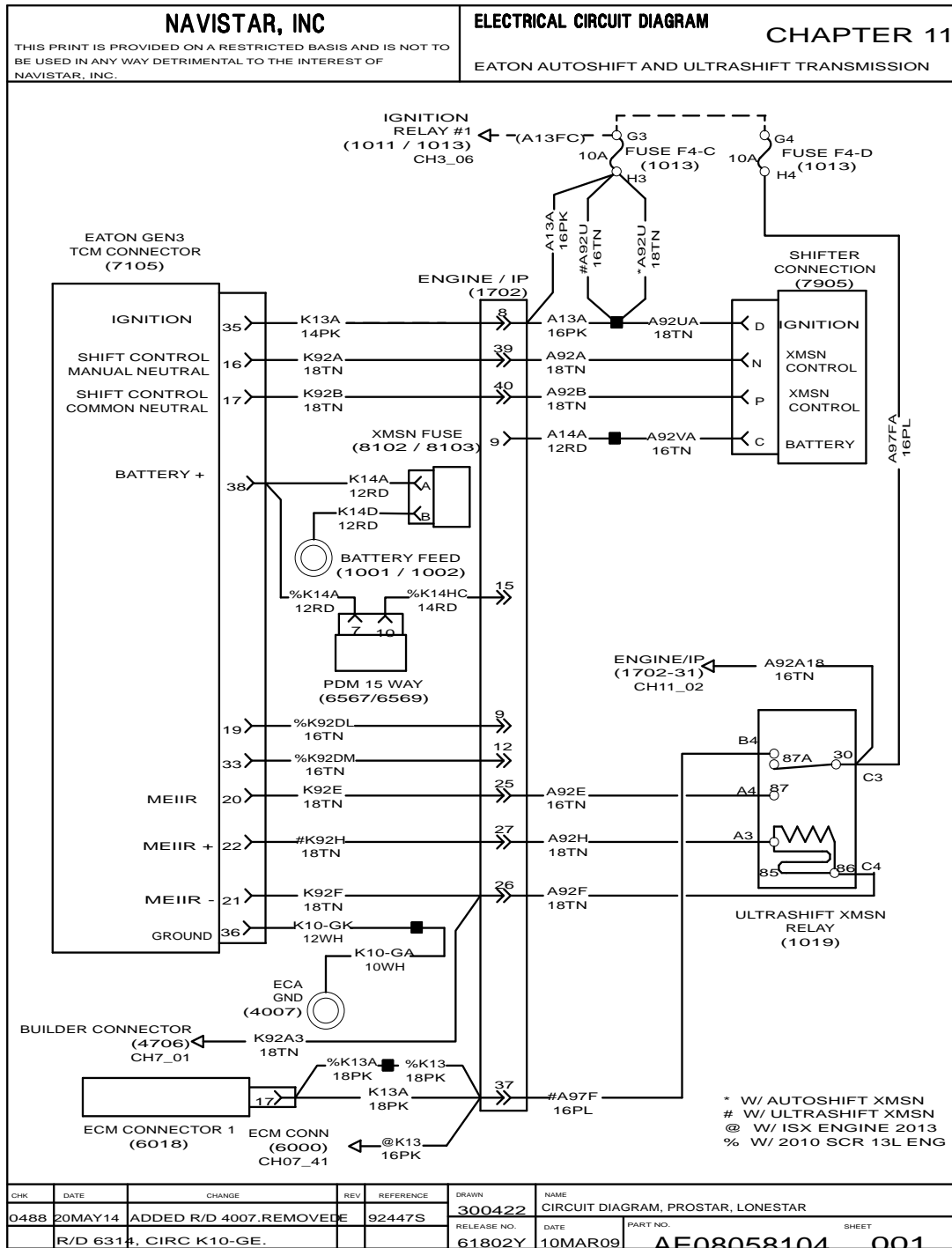

Figure 363 Eaton Autoshift and Ultrashift Transmission

11.11. ALLISON TRANSMISSION (2010 SCR 13L ENG) (CONT.), P. 7

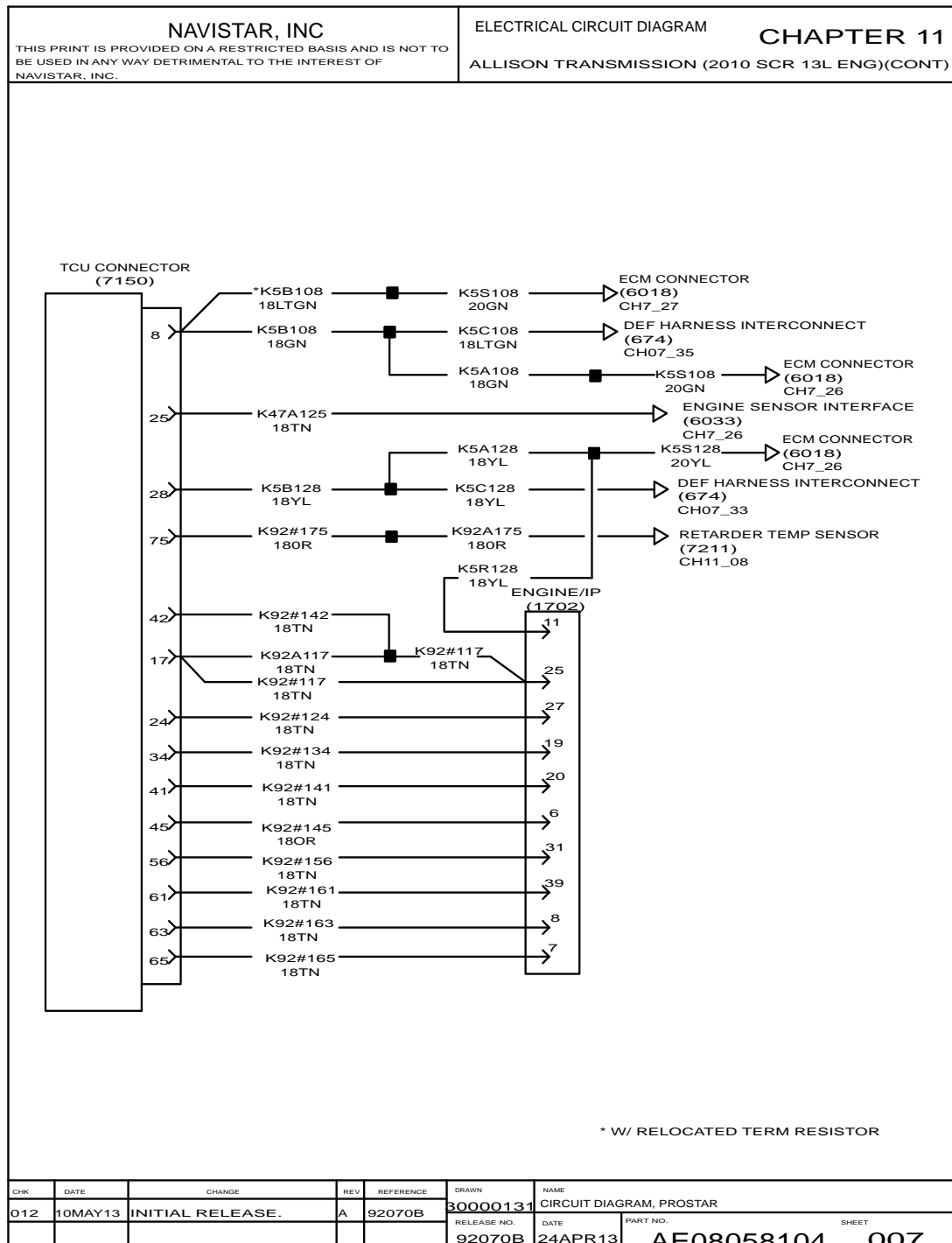

Figure 373 Allison Transmission (2010 SCR 13L Eng) (Cont.)

12.3. HVAC SYSTEM – CAB (CONT.), P. 3

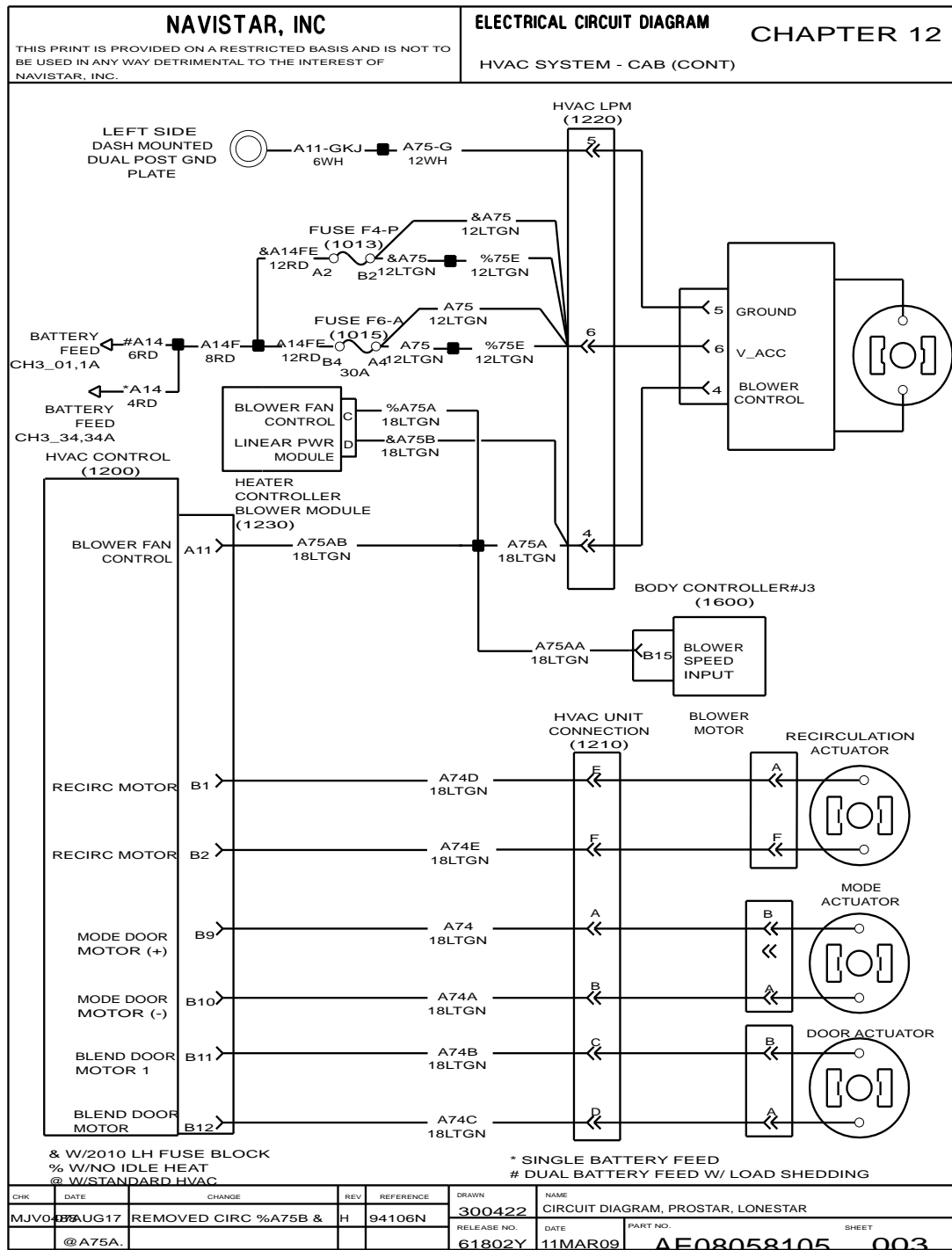

Figure 383 HVAC System – Cab (Cont.)

12.13. NO IDLE HEATER, ESPAR IN CAB FUEL FIRED HEATER, P. 12

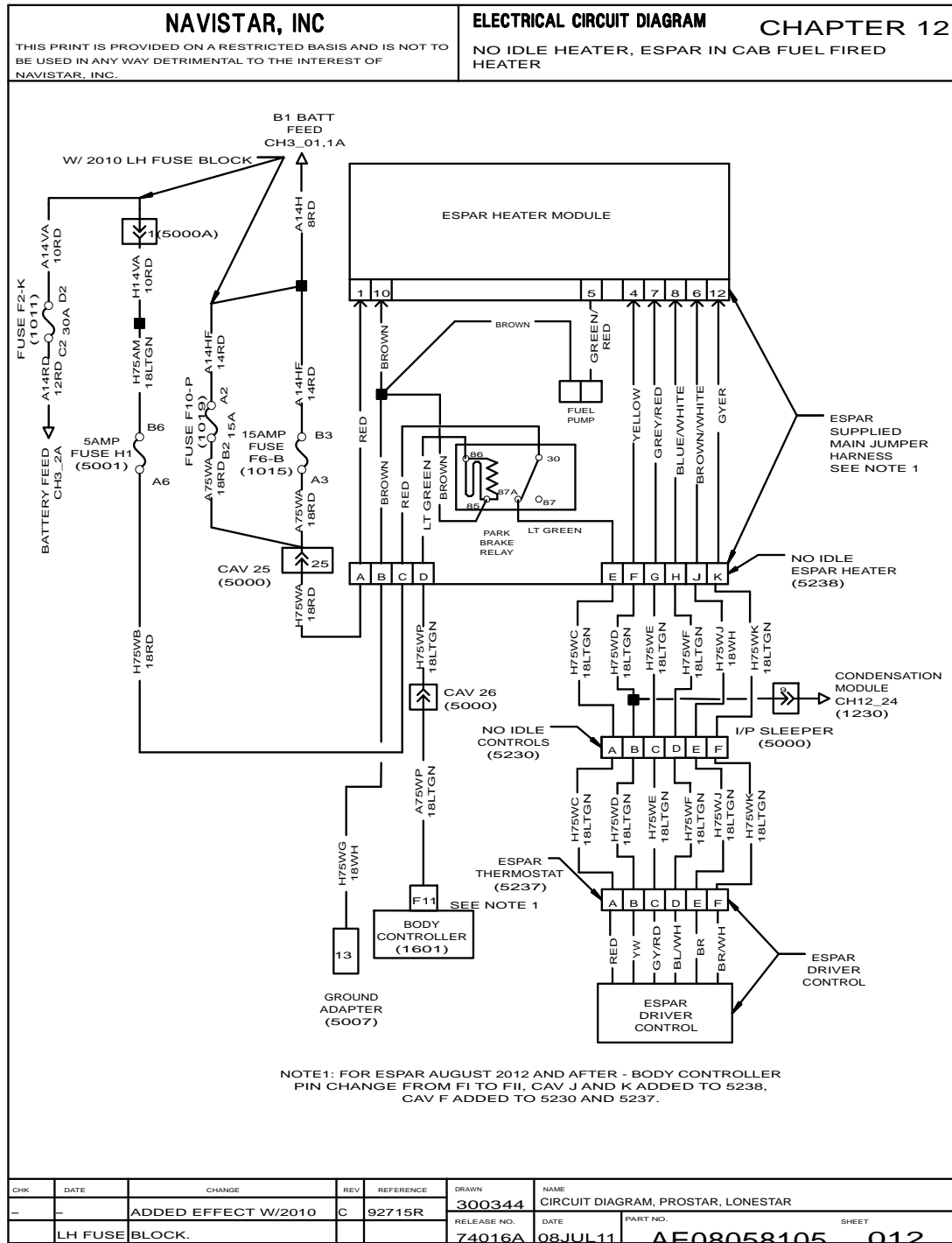

Figure 393 No Idle Heater, ESPAR in Cab Fuel Fired Heater

12.23. HVAC SYSTEM – SLEEPER WITH BERGSTROM NO IDLE FUEL FIRED HEATER, P. 19

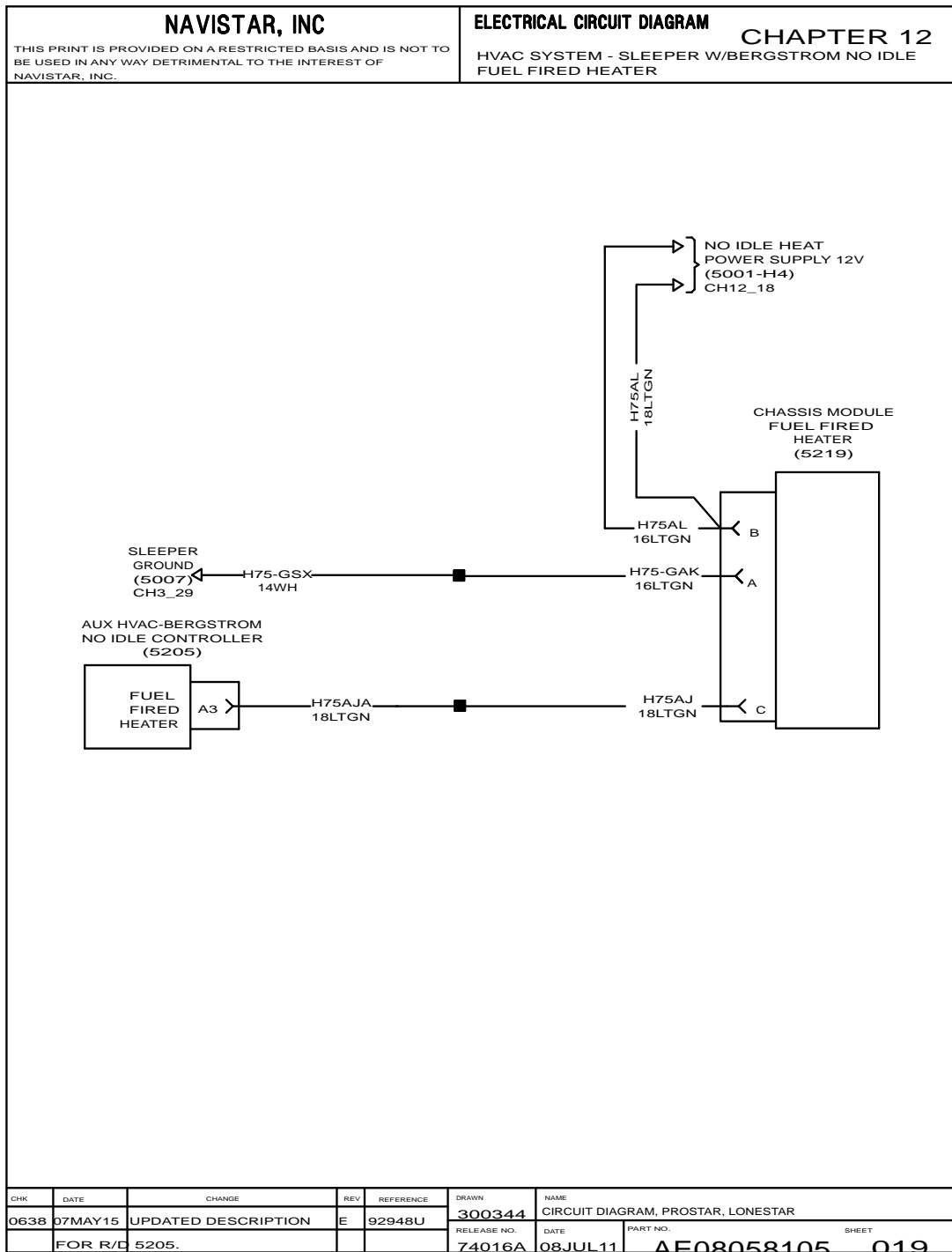

Figure 403 HVAC System – Sleeper with Bergstrom No Idle Fuel Fired Heater

13.3. POWER SOURCE – BUNK, P. 3

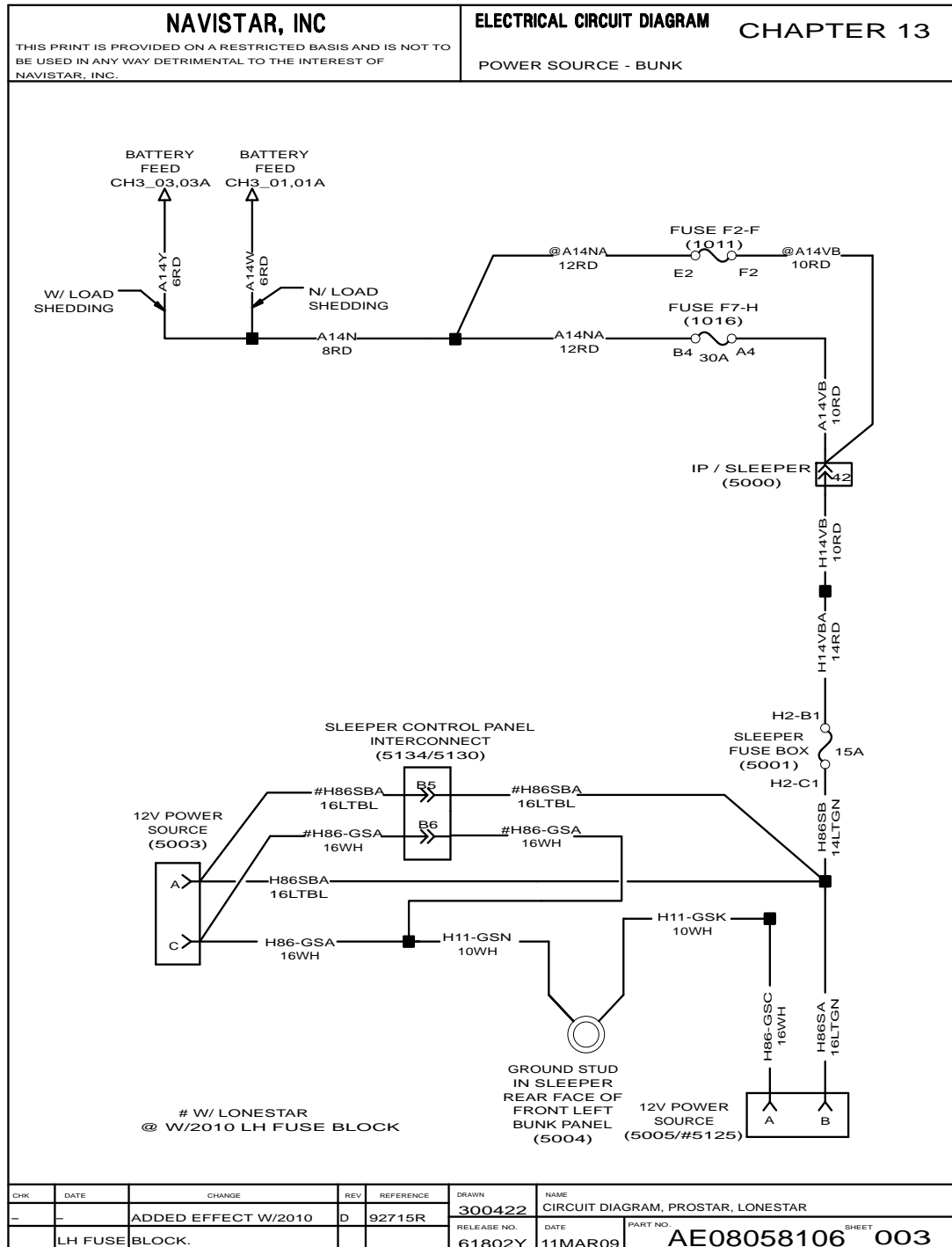

Figure 413 Power Source – Bunk

14.5. CONNECTOR BODY COMPOSITE (100A), (100B), (113F1), (113M1), (166M), (344), P. 3

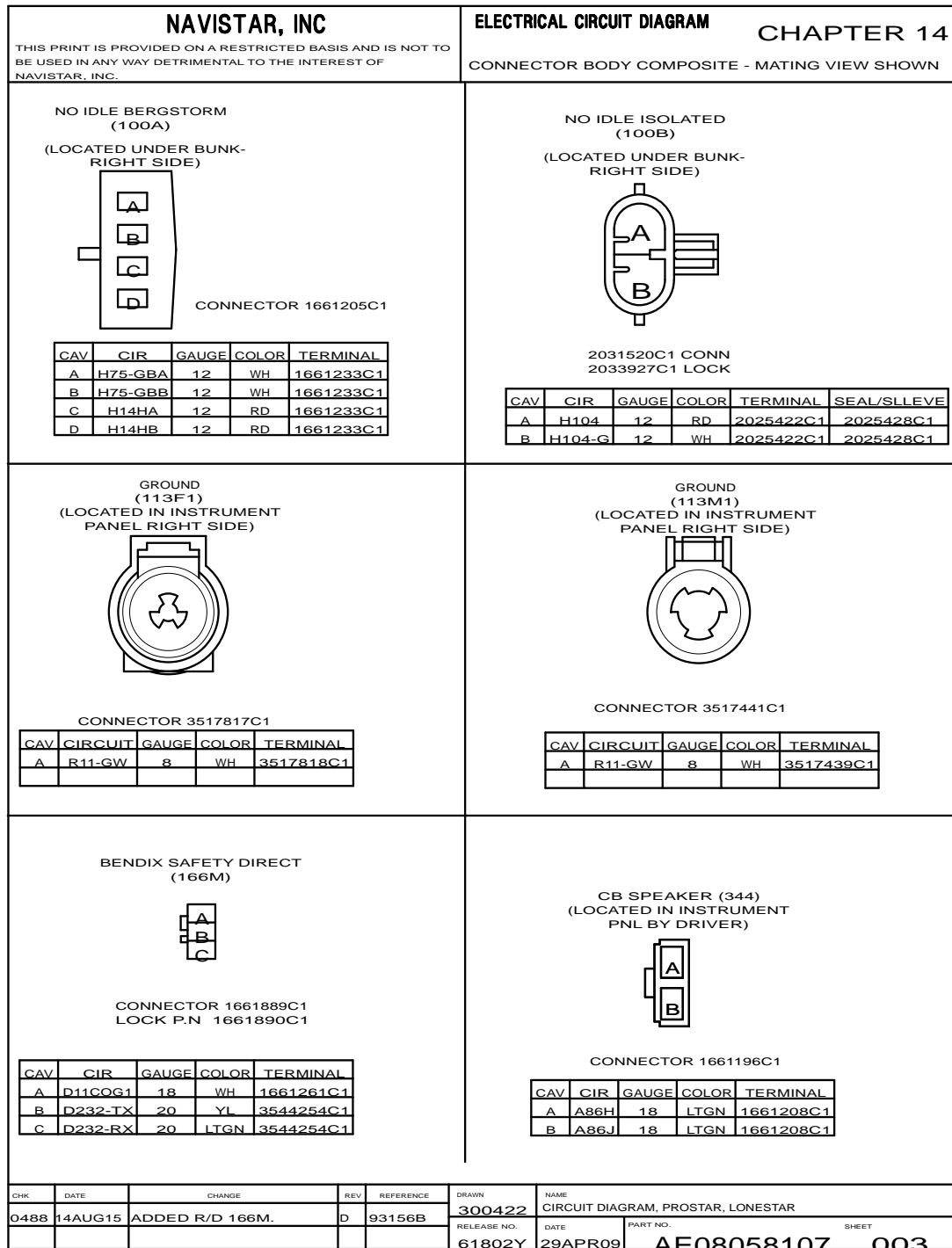

Figure 423 Connector Body Composite (100A), (100B), (113F1), (113M1), (166M), (344)

14.15. CONNECTOR BODY COMPOSITE (679), P. 4H

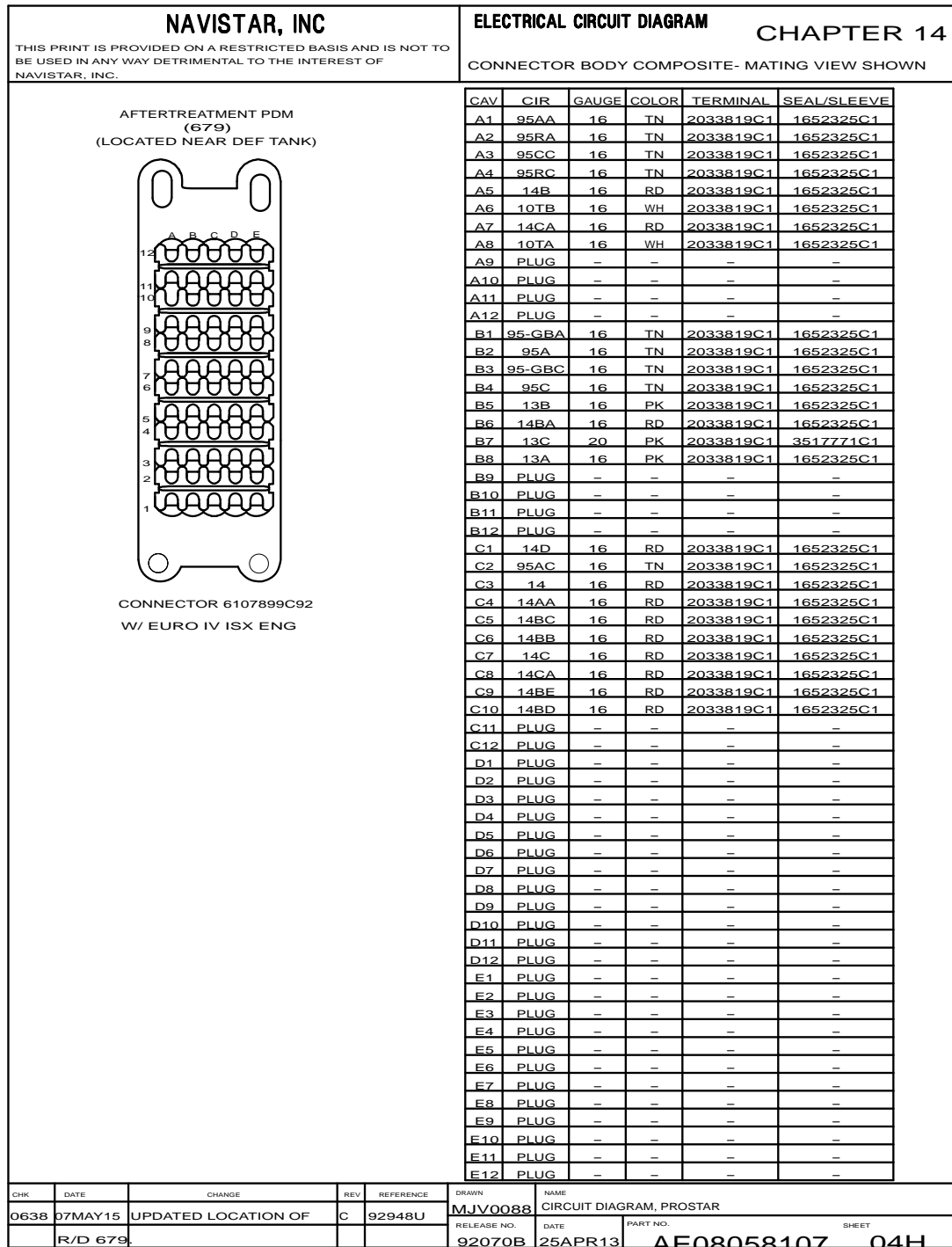

Figure 433 Connector Body Composite (679)

14.25. CONNECTOR BODY COMPOSITE (1011), P. 7B

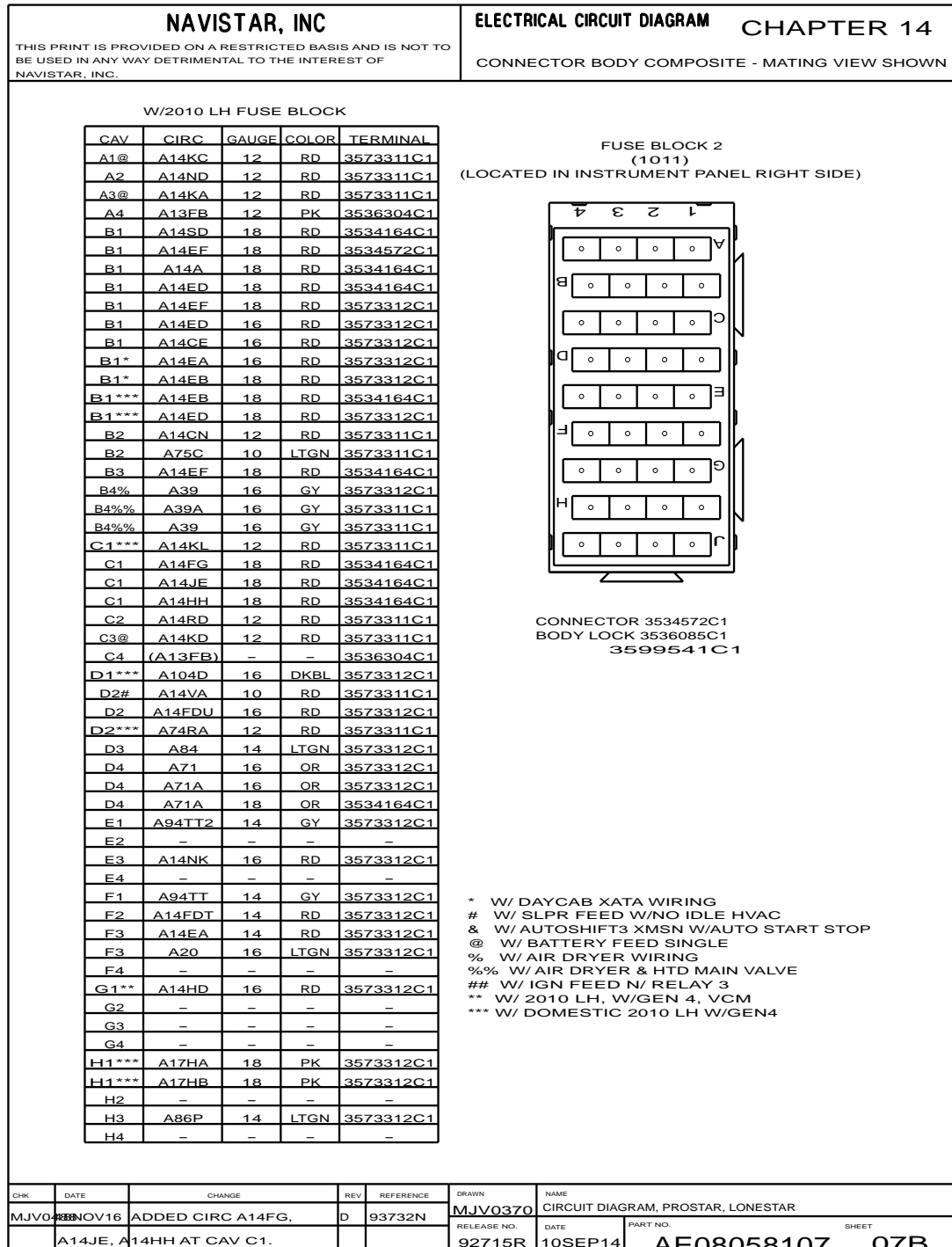

Figure 443 Connector Body Composite (1011)

14.35. CONNECTOR BODY COMPOSITE (1016), P. 12

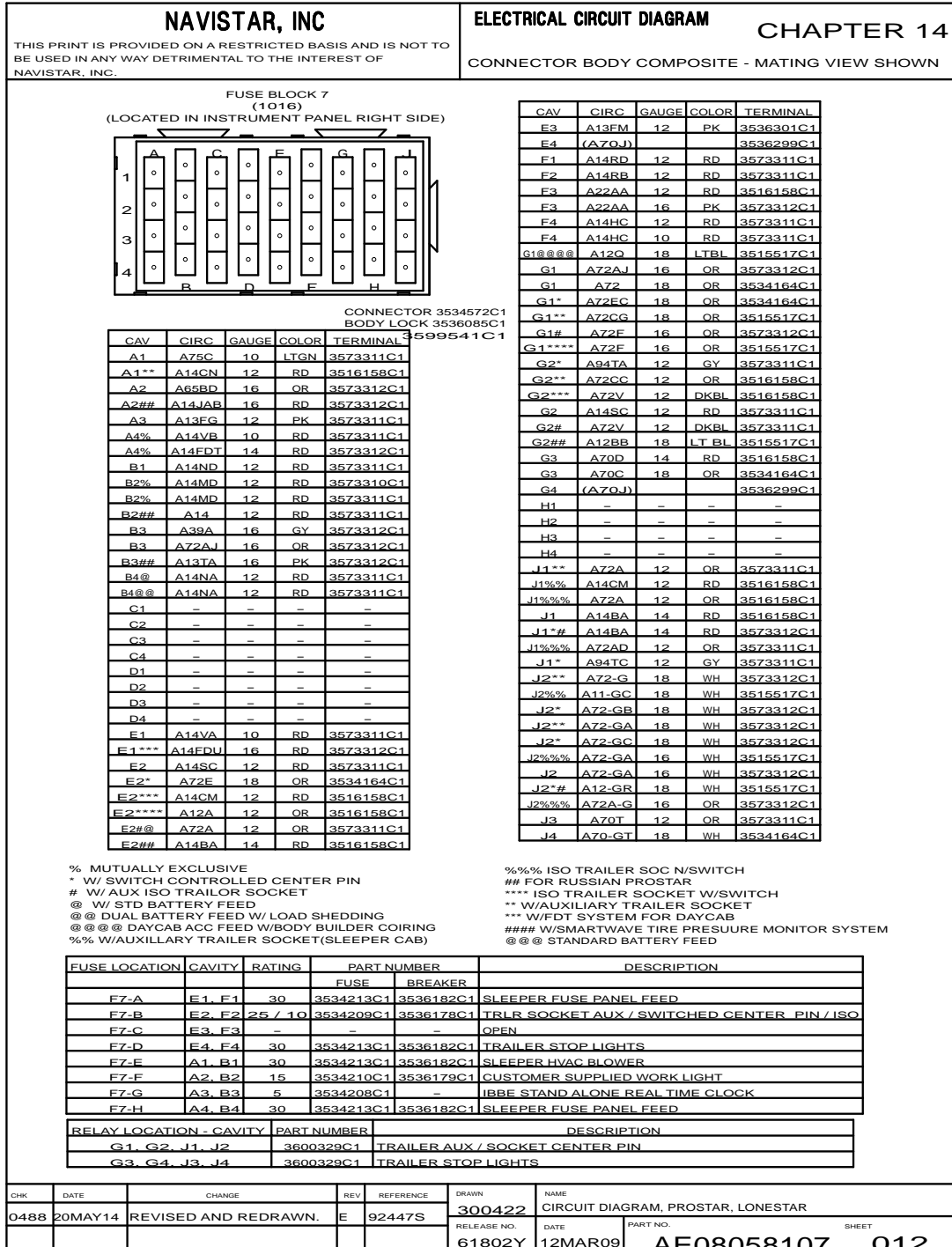

Figure 453 Connector Body Composite (1016)

14.45. CONNECTOR BODY COMPOSITE (1020), P. 16

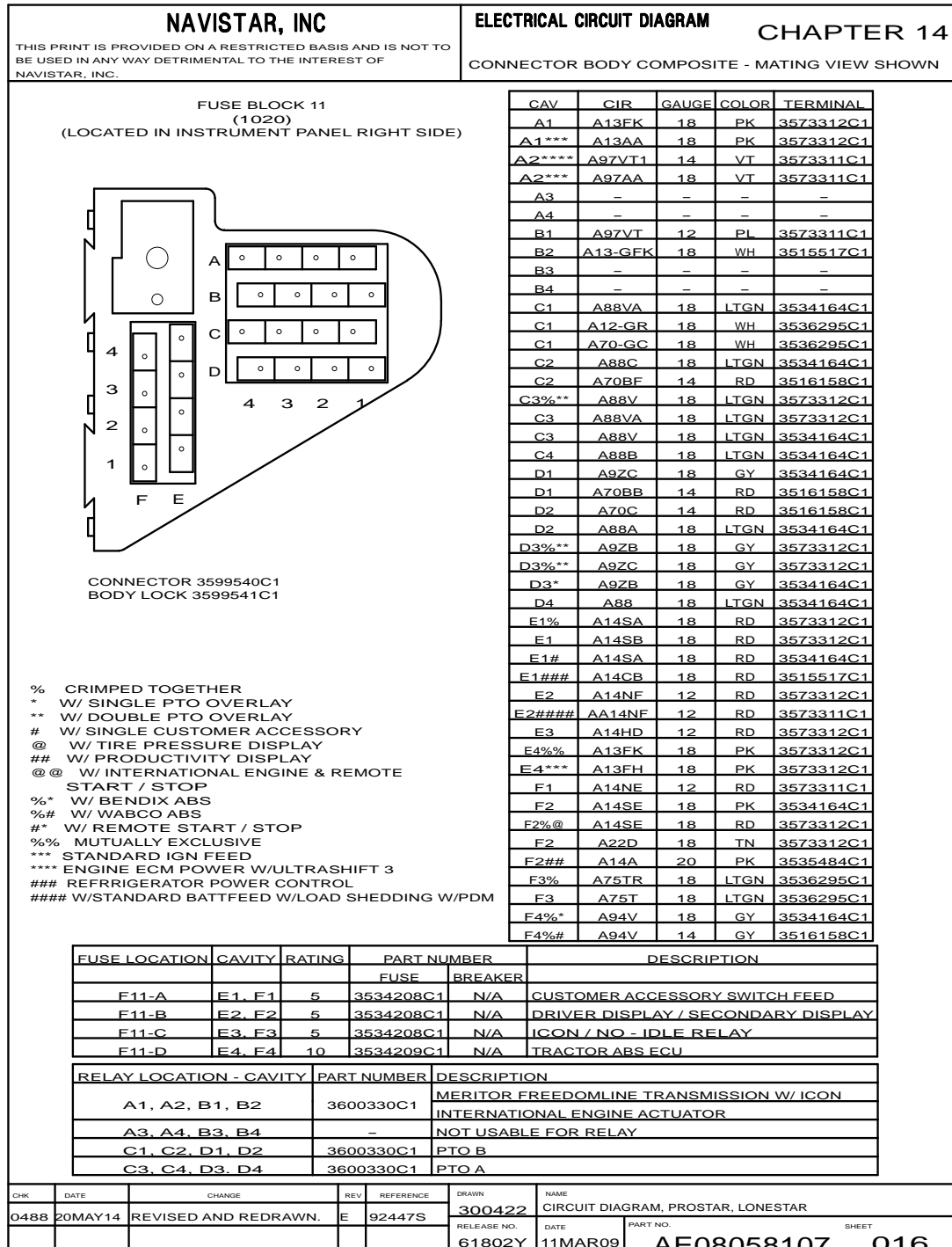

Figure 463 Connector Body Composite (1020)

14.55. CONNECTOR BODY COMPOSITE (1121M), (1122M), (1123M), (1124M), P. 21A

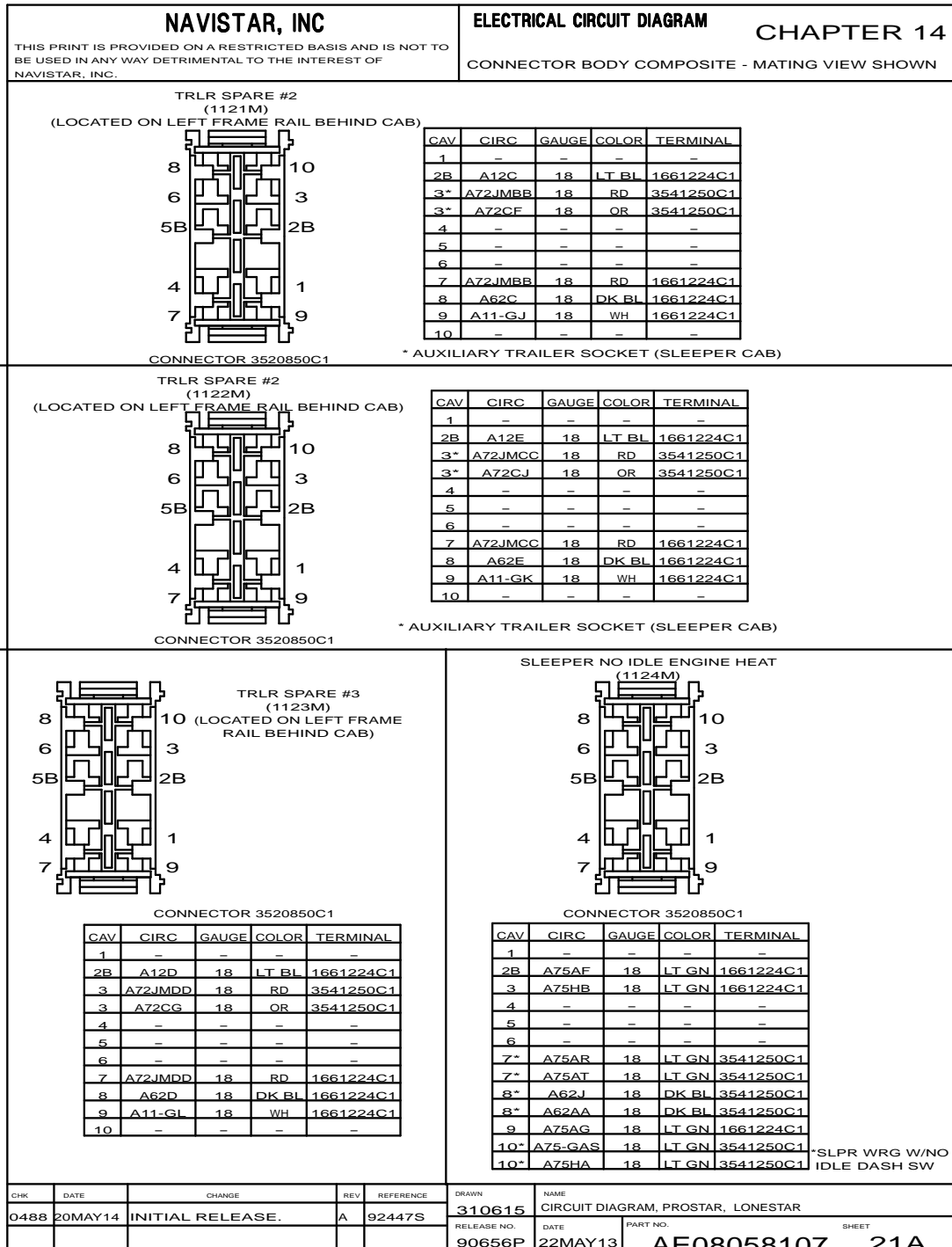

Figure 473 Connector Body Composite (1121M), (1122M), (1123M), (1124M)

14.65. CONNECTOR BODY COMPOSITE (1503), (1510), P. 26A

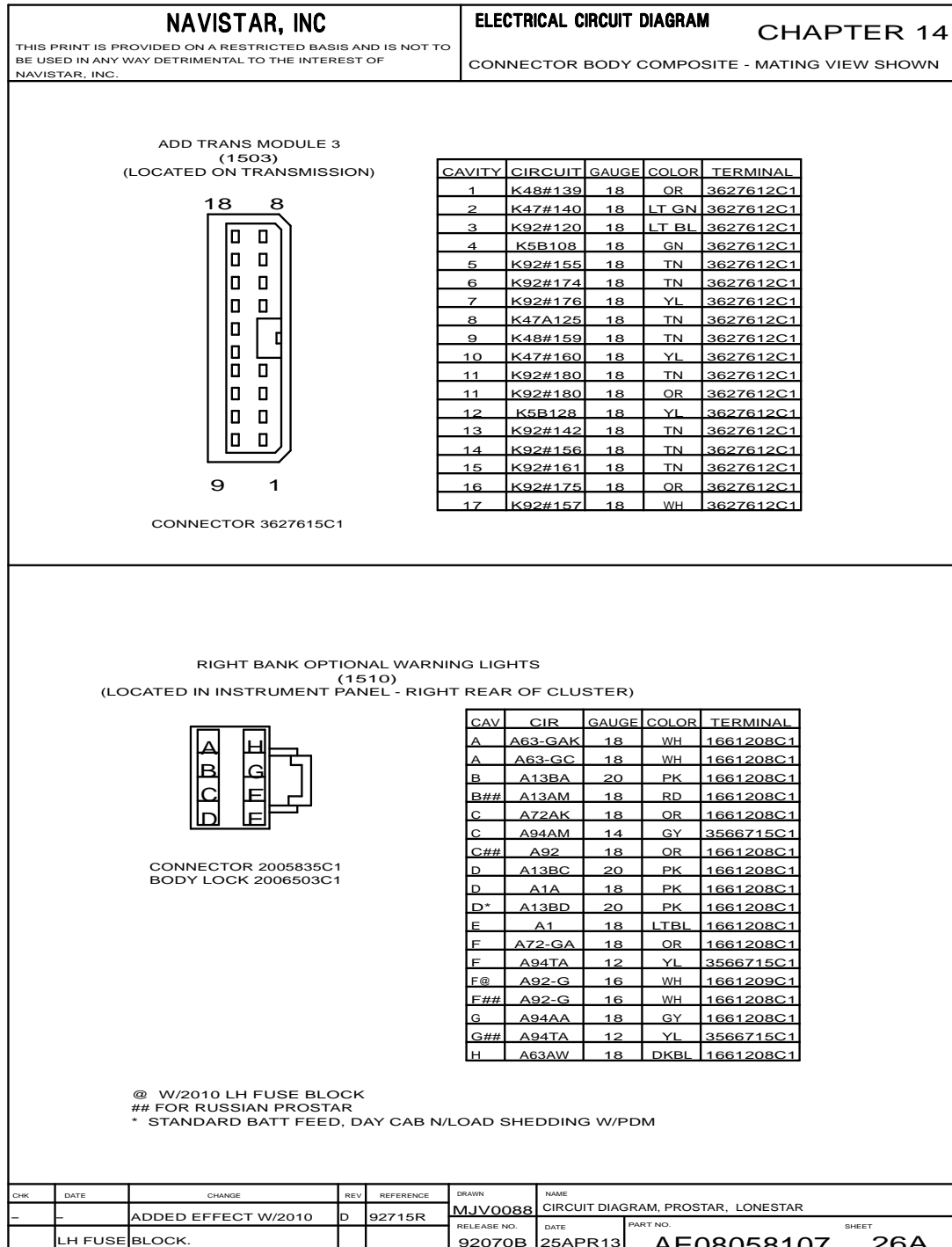

Figure 483 Connector Body Composite (1503), (1510)

14.75. CONNECTOR BODY COMPOSITE (1700), P. 34A

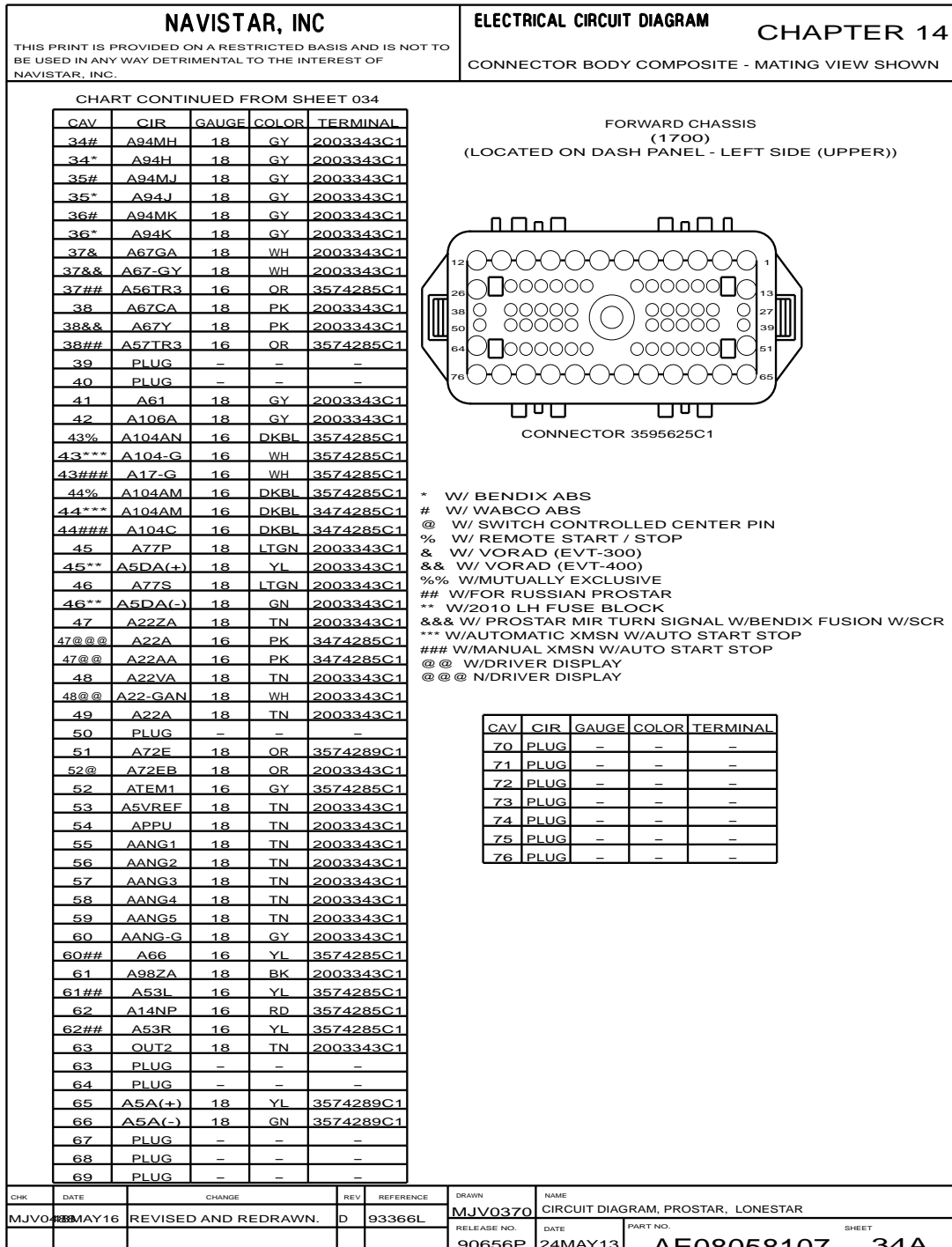

Figure 493 Connector Body Composite (1700)

14.85. CONNECTOR BODY COMPOSITE (1800F), P. 41

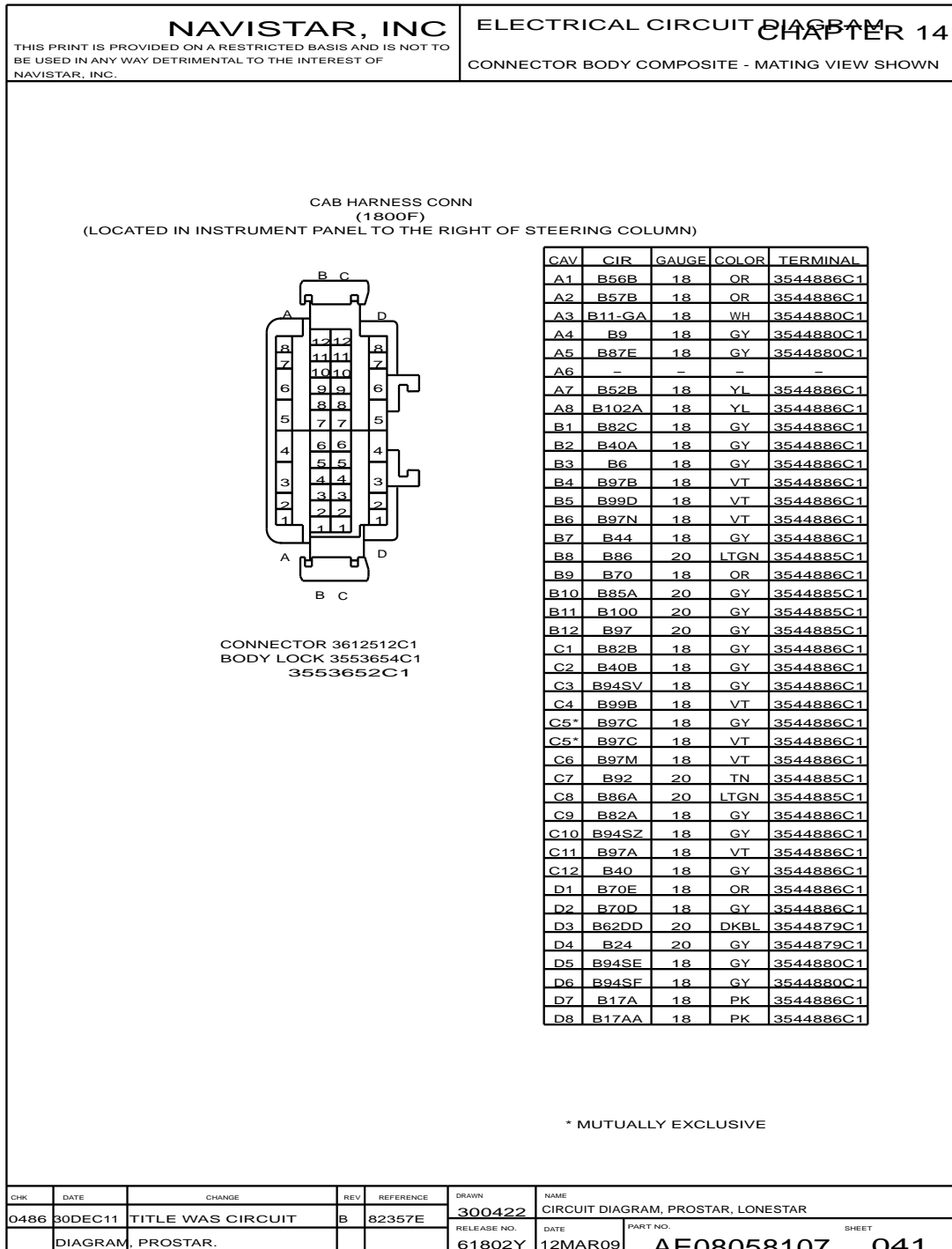

Figure 503 Connector Body Composite (1800F)

14.95. CONNECTOR BODY COMPOSITE (1874B), (1874C), (1901), (1903), P. 48A

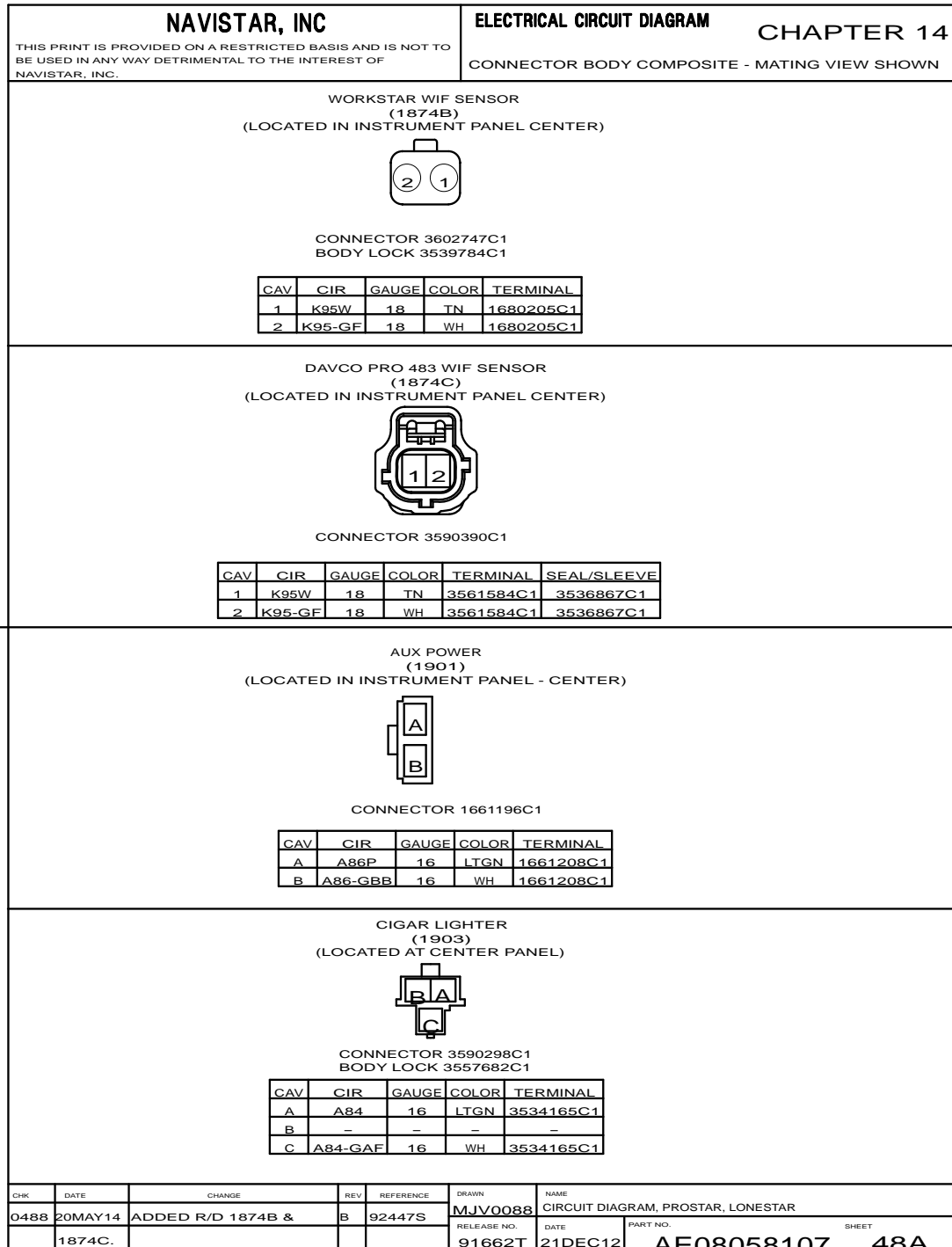

Figure 513 Connector Body Composite (1874B), (1874C), (1901), (1903)

14.105. CONNECTOR BODY COMPOSITE (1965), P. 54A

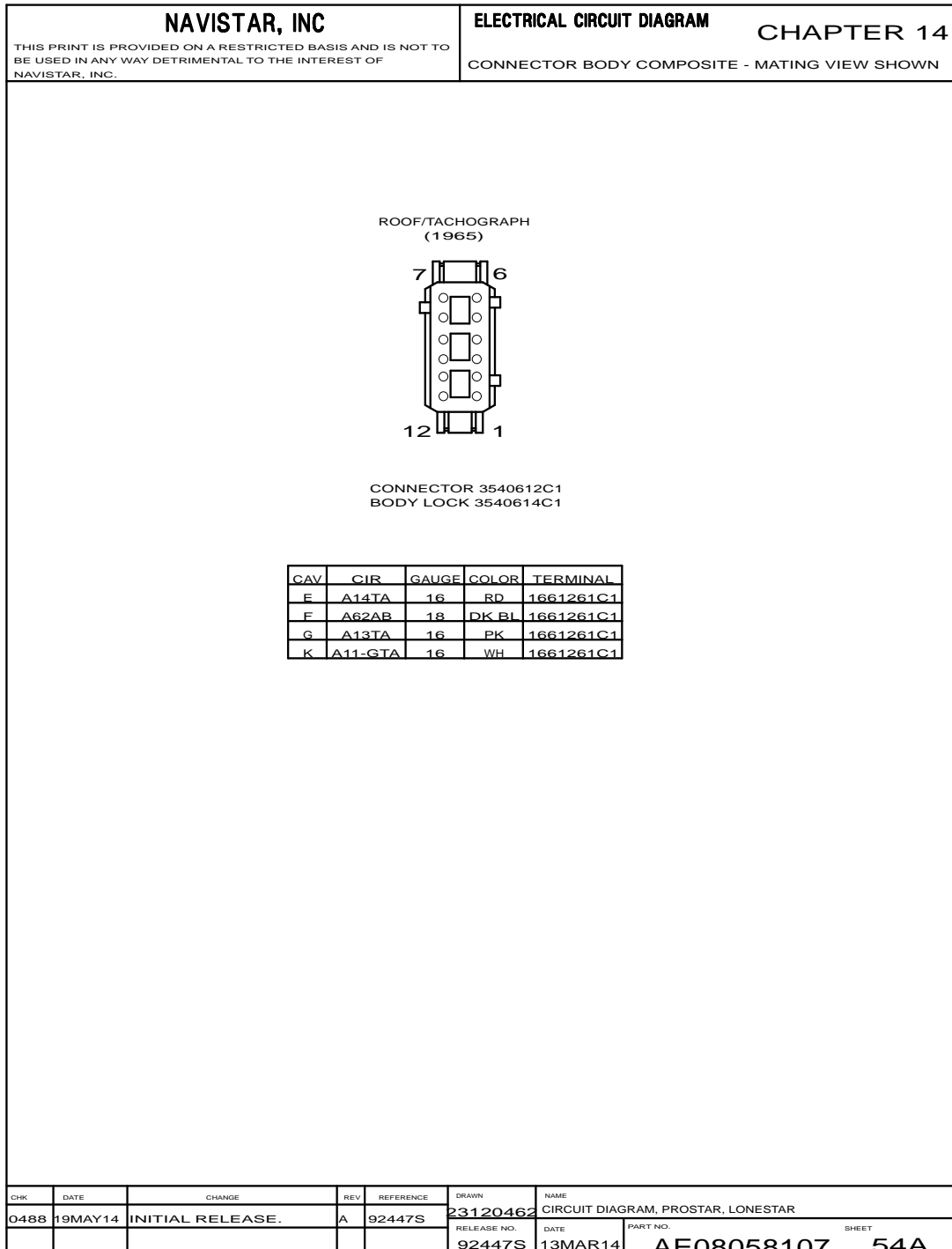

Figure 523 Connector Body Composite (1965)

14.115. CONNECTOR BODY COMPOSITE (3200), (3200F), (3201), (3201M), (3202M), (3203), P. 64

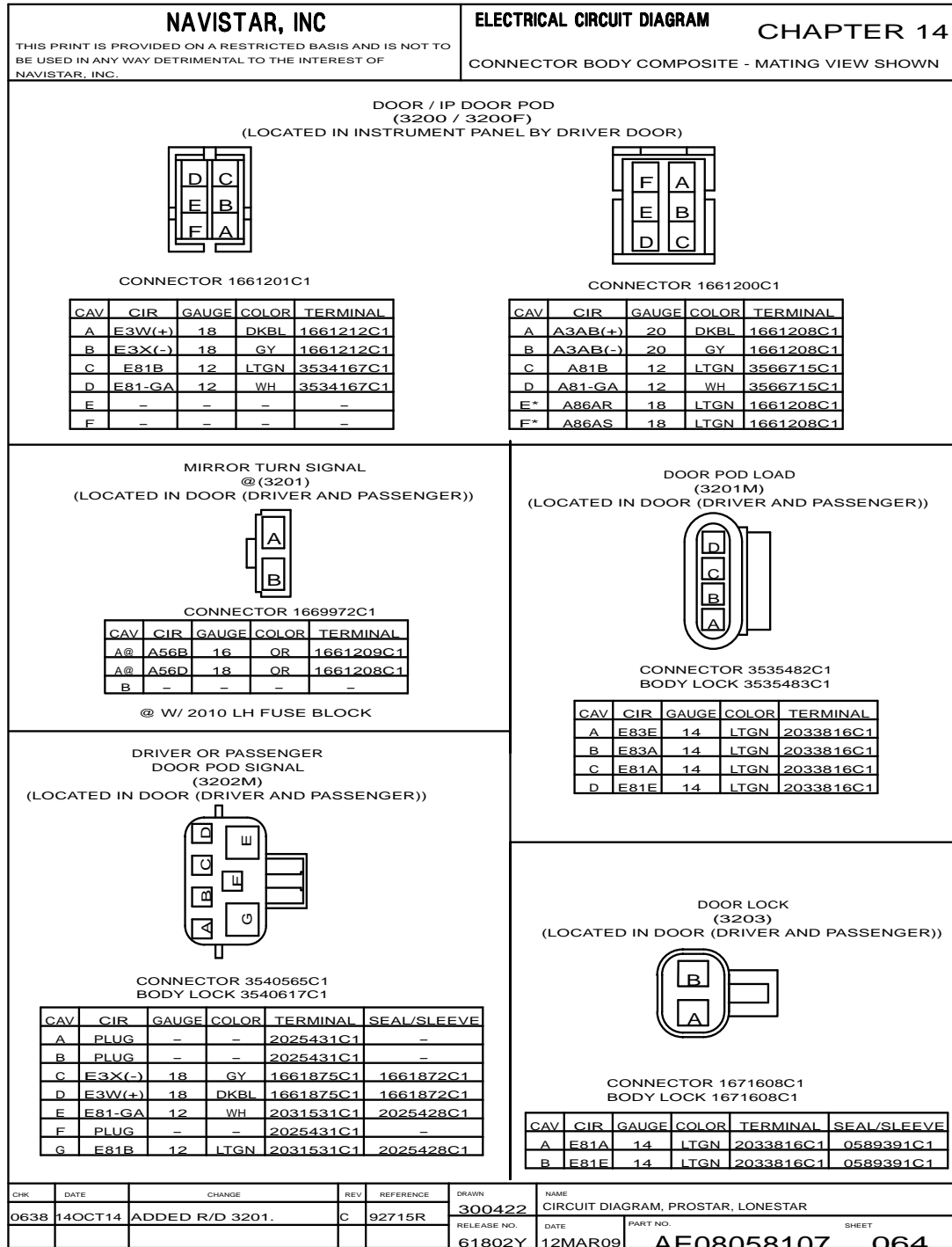

Figure 533 Connector Body Composite (3200), (3200F), (3201), (3201M), (3202M), (3203)

14.125. CONNECTOR BODY COMPOSITE (5001), P. 70

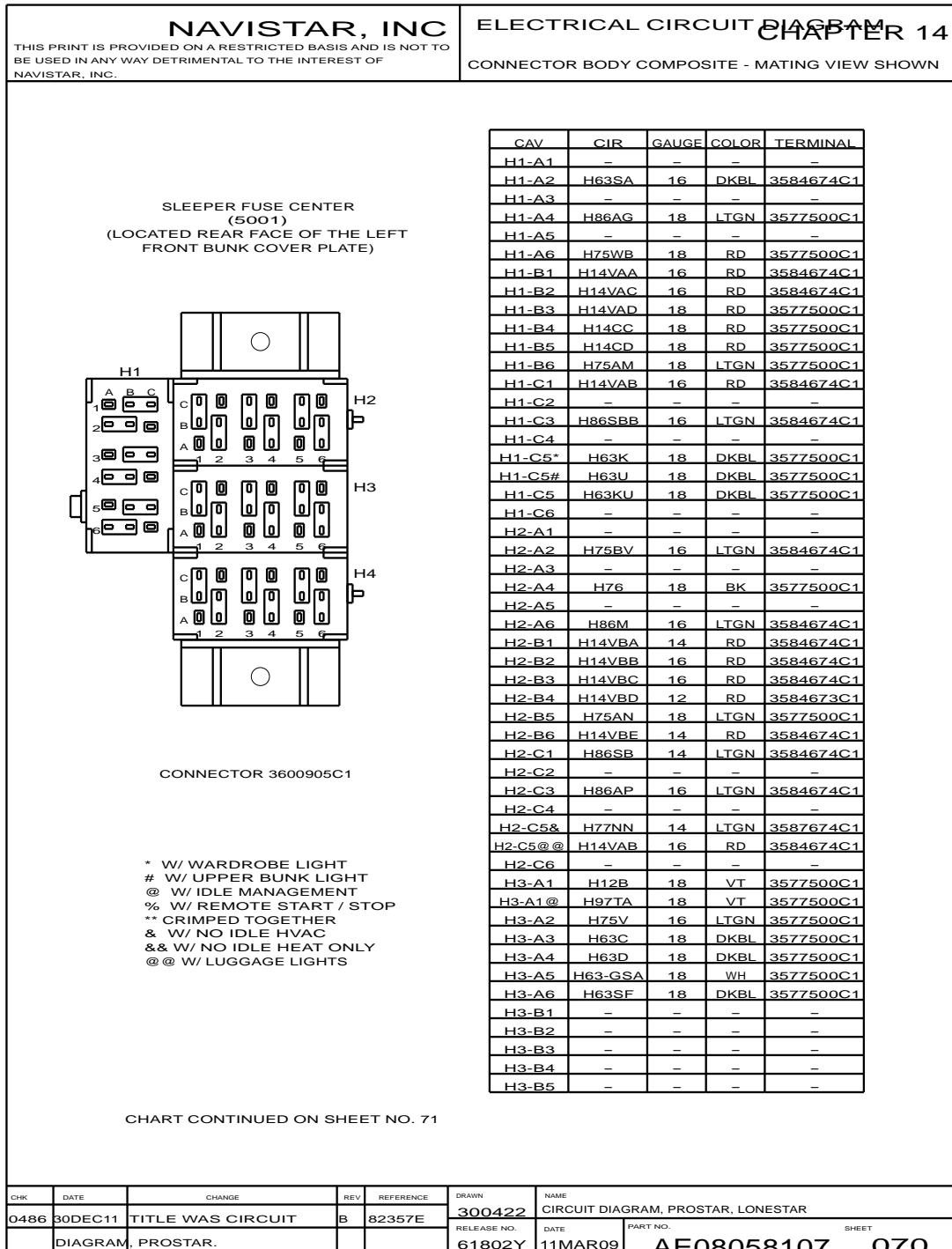

Figure 543 Connector Body Composite (5001)

14.135. CONNECTOR BODY COMPOSITE (5117), (5118), (5119), P. 77

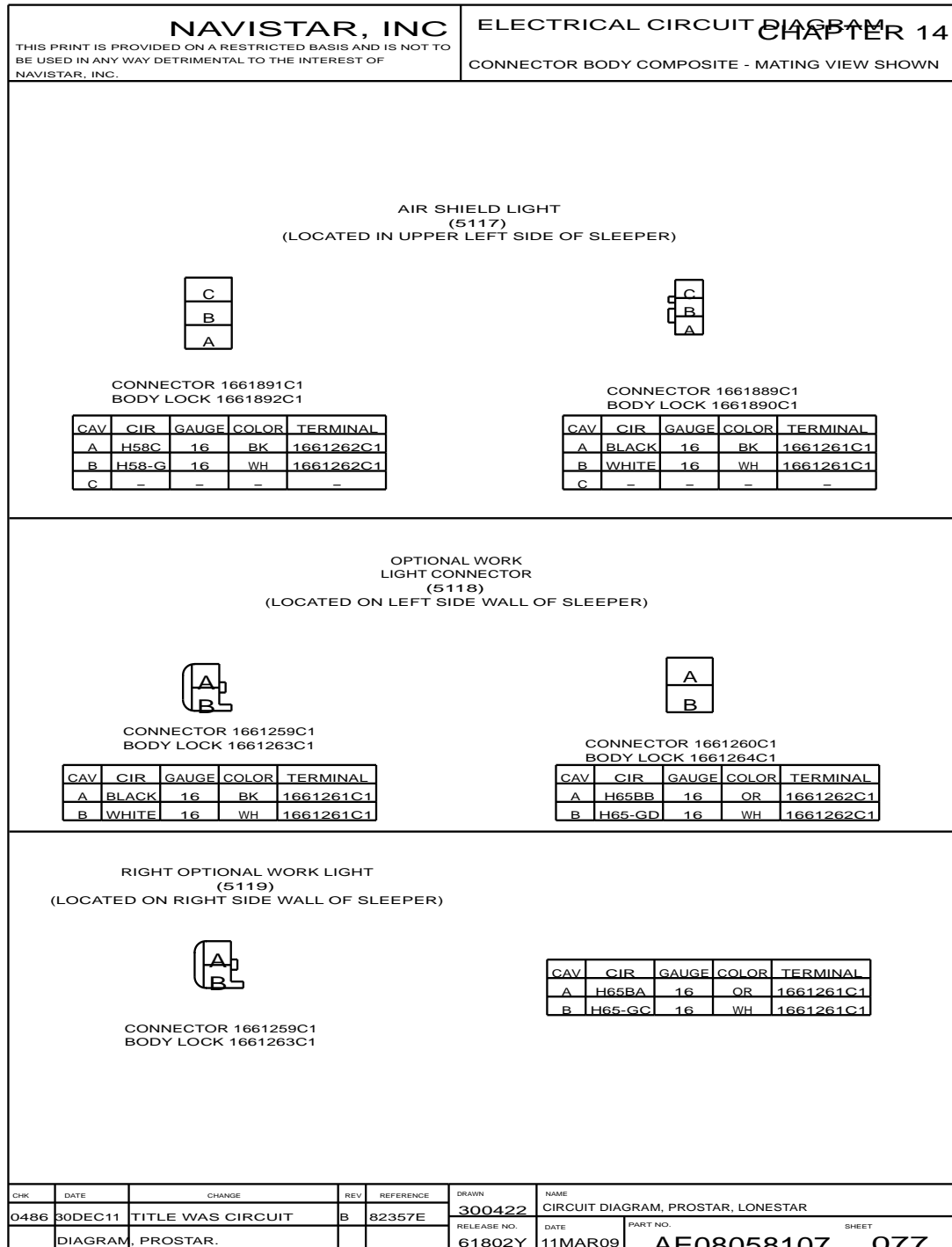

Figure 553 Connector Body Composite (5117), (5118), (5119)

14.145. CONNECTOR BODY COMPOSITE (5235), (5236), (5237), (5238), P. 84A

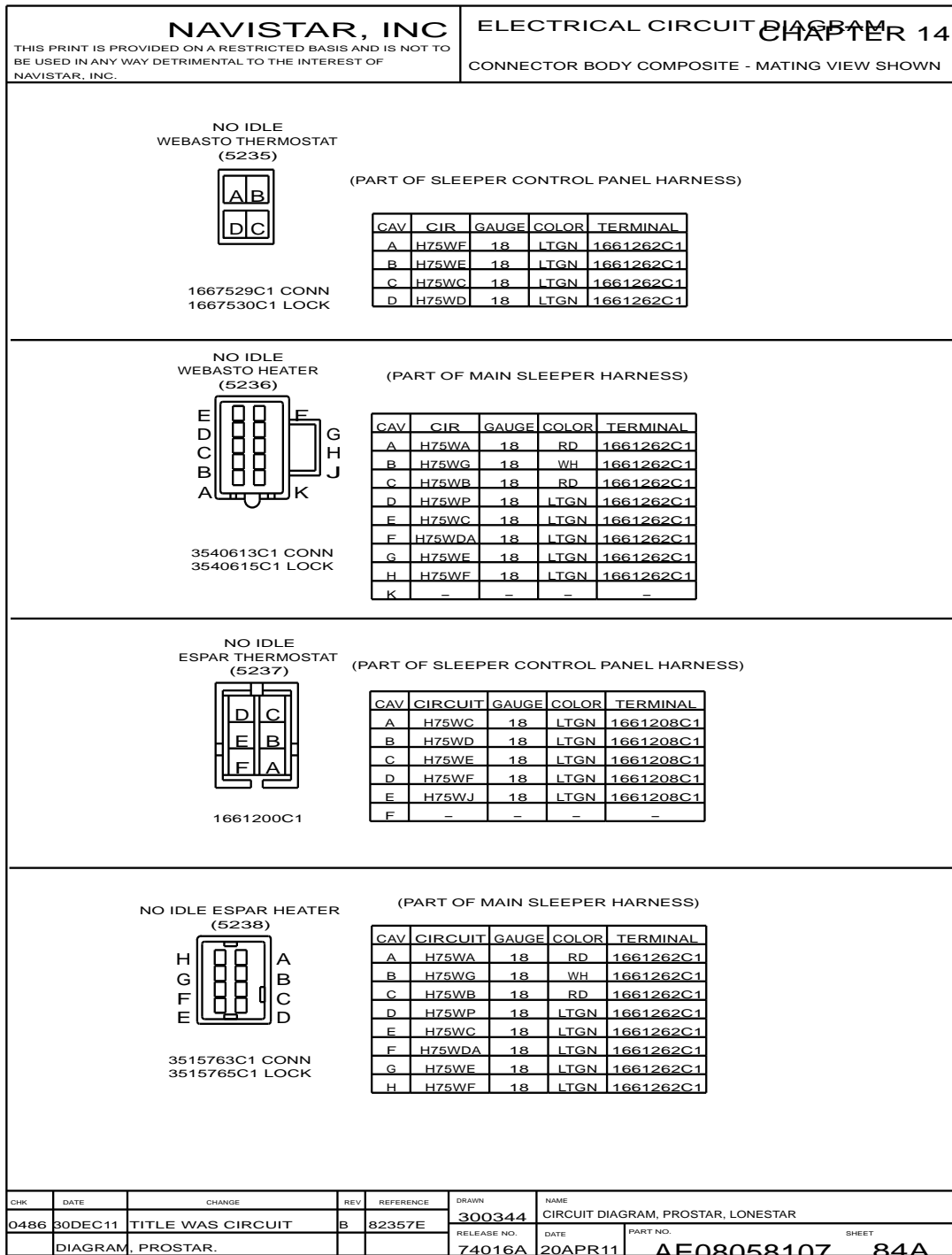

Figure 563 Connector Body Composite (5235), (5236), (5237), (5238)

14.155. CONNECTOR BODY COMPOSITE (5909), (5925), (5926), (5927), (5930M), (5940), P. 91

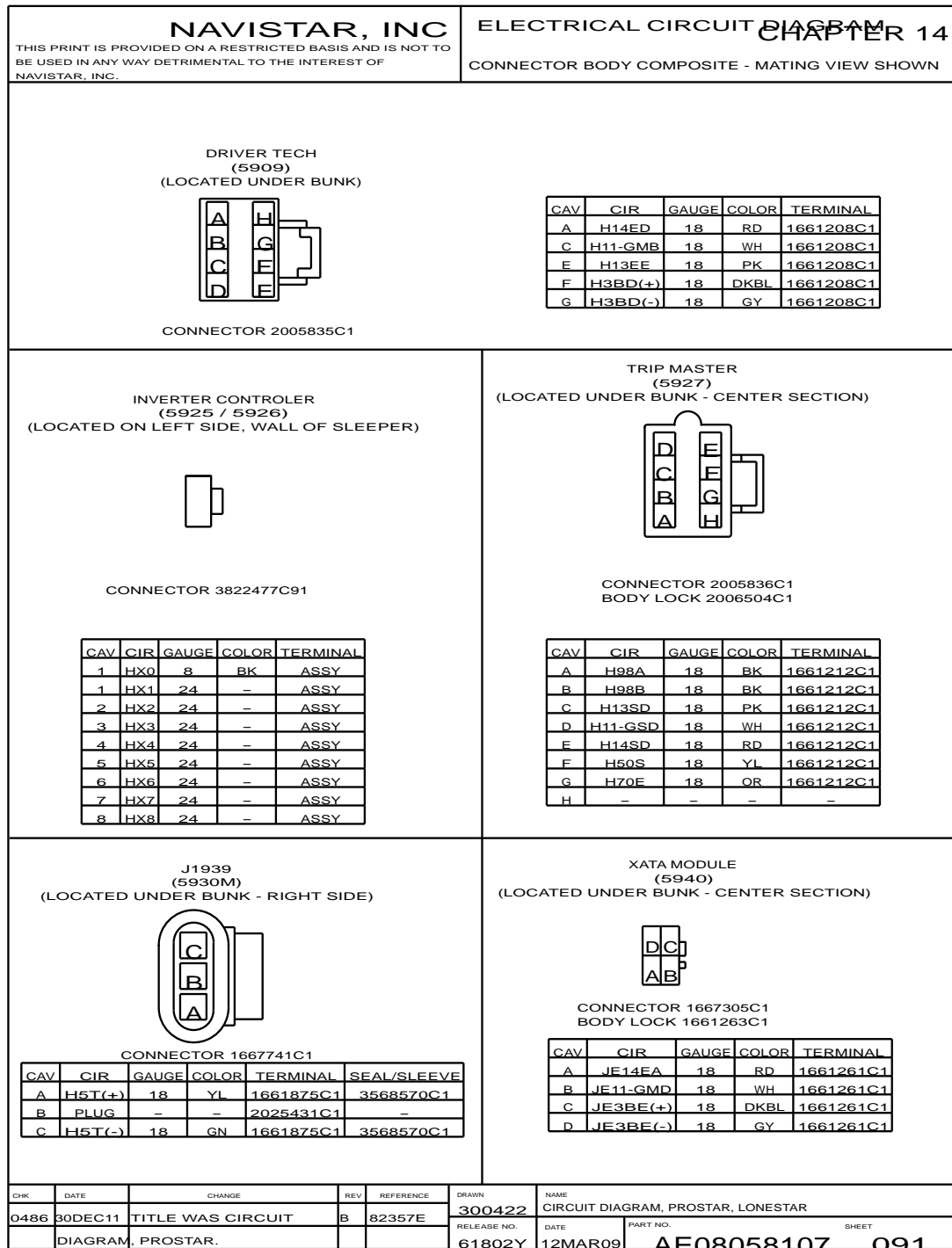

Figure 573 Connector Body Composite (5909), (5925), (5926), (5927), (5930M), (5940)

14.165. CONNECTOR BODY COMPOSITE (6400A), (6401), (6408), (6420), (6566), P. 95A



NAVISTAR, INC				ELECTRICAL CIRCUIT DIAGRAM		CHAPTER 14																																																								
THIS PRINT IS PROVIDED ON A RESTRICTED BASIS AND IS NOT TO BE USED IN ANY WAY DETRIMENTAL TO THE INTEREST OF NAVISTAR, INC.				CONNECTOR BODY COMPOSITE - MATING VIEW SHOWN																																																										
<p style="text-align: center;">FAN SOLENOID PROSTAR (6400A)</p> <div style="display: flex; justify-content: space-around; align-items: center;">  <table border="1" style="font-size: x-small; border-collapse: collapse;"> <thead> <tr> <th>CAV</th> <th>CIRCUIT</th> <th>GAUGE</th> <th>COLOR</th> <th>TERMINAL</th> <th>SEAL/SLEEVE</th> </tr> </thead> <tbody> <tr> <td>A</td> <td>K23</td> <td>18</td> <td>TN</td> <td>1661875C1</td> <td>3568570C1</td> </tr> <tr> <td>B</td> <td>K23-G</td> <td>18</td> <td>WH</td> <td>1661875C1</td> <td>3568570C1</td> </tr> </tbody> </table> </div> <p style="text-align: center; margin-top: 10px;">CONNECTOR 3522068C1 BODY LOCK 1661874C1</p>								CAV	CIRCUIT	GAUGE	COLOR	TERMINAL	SEAL/SLEEVE	A	K23	18	TN	1661875C1	3568570C1	B	K23-G	18	WH	1661875C1	3568570C1																																					
CAV	CIRCUIT	GAUGE	COLOR	TERMINAL	SEAL/SLEEVE																																																									
A	K23	18	TN	1661875C1	3568570C1																																																									
B	K23-G	18	WH	1661875C1	3568570C1																																																									
<p style="text-align: center;">COOLANT LEVEL SENSOR (6401)</p> <div style="display: flex; justify-content: space-around; align-items: center;">  <table border="1" style="font-size: x-small; border-collapse: collapse;"> <thead> <tr> <th>CAV</th> <th>CIRCUIT</th> <th>GAUGE</th> <th>COLOR</th> <th>TERMINAL</th> <th>SEAL/SLEEVE</th> </tr> </thead> <tbody> <tr> <td>A#</td> <td>K34</td> <td>16</td> <td>TN</td> <td>2033819C1</td> <td>1652325C1</td> </tr> <tr> <td>B#</td> <td>K34A</td> <td>16</td> <td>TN</td> <td>2033819C1</td> <td>1652325C1</td> </tr> </tbody> </table> </div> <p style="text-align: center; margin-top: 10px;">CONNECTOR 1671610C1</p>								CAV	CIRCUIT	GAUGE	COLOR	TERMINAL	SEAL/SLEEVE	A#	K34	16	TN	2033819C1	1652325C1	B#	K34A	16	TN	2033819C1	1652325C1																																					
CAV	CIRCUIT	GAUGE	COLOR	TERMINAL	SEAL/SLEEVE																																																									
A#	K34	16	TN	2033819C1	1652325C1																																																									
B#	K34A	16	TN	2033819C1	1652325C1																																																									
<p style="text-align: center;">LOW COOLANT SENDER L/S (6408)</p> <div style="display: flex; justify-content: space-around; align-items: center;">  <table border="1" style="font-size: x-small; border-collapse: collapse;"> <thead> <tr> <th>CAV</th> <th>CIRCUIT</th> <th>GAUGE</th> <th>COLOR</th> <th>TERMINAL</th> <th>SEAL/SLEEVE</th> </tr> </thead> <tbody> <tr> <td>A</td> <td>K34D</td> <td>18</td> <td>TN</td> <td>3554322C1</td> <td>3554318C1</td> </tr> <tr> <td>B</td> <td>K34B</td> <td>18</td> <td>TN</td> <td>3554322C1</td> <td>3554318C1</td> </tr> </tbody> </table> </div> <p style="text-align: center; margin-top: 10px;">CONNECTOR 3662425C1 BODY LOCK 3662518C1</p>								CAV	CIRCUIT	GAUGE	COLOR	TERMINAL	SEAL/SLEEVE	A	K34D	18	TN	3554322C1	3554318C1	B	K34B	18	TN	3554322C1	3554318C1																																					
CAV	CIRCUIT	GAUGE	COLOR	TERMINAL	SEAL/SLEEVE																																																									
A	K34D	18	TN	3554322C1	3554318C1																																																									
B	K34B	18	TN	3554322C1	3554318C1																																																									
<p style="text-align: center;">VARIABLE SPEED FAN (6420)</p> <div style="display: flex; justify-content: space-around; align-items: center;">  <table border="1" style="font-size: x-small; border-collapse: collapse;"> <thead> <tr> <th>CAV</th> <th>CIRCUIT</th> <th>GAUGE</th> <th>COLOR</th> <th>TERMINAL</th> </tr> </thead> <tbody> <tr><td>1</td><td>K23-G</td><td>18</td><td>TN</td><td>3518963C1</td></tr> <tr><td>1</td><td>K23-G</td><td>18</td><td>TN</td><td>3518963C1</td></tr> <tr><td>2</td><td>K23A1</td><td>18</td><td>TN</td><td>3518963C1</td></tr> <tr><td>2</td><td>K23A1</td><td>18</td><td>TN</td><td>3518963C1</td></tr> <tr><td>3</td><td>KB23</td><td>18</td><td>TN</td><td>3518963C1</td></tr> <tr><td>3</td><td>K23</td><td>18</td><td>TN</td><td>3518963C1</td></tr> <tr><td>4</td><td>K23B1</td><td>18</td><td>WH</td><td>3518963C1</td></tr> <tr><td>4</td><td>K23B1</td><td>18</td><td>WH</td><td>3518963C1</td></tr> <tr><td>5</td><td>K23C</td><td>18</td><td>TN</td><td>3518963C1</td></tr> <tr><td>5</td><td>K23C</td><td>18</td><td>TN</td><td>3518963C1</td></tr> </tbody> </table> </div> <p style="text-align: center; margin-top: 10px;">CONNECTOR 3579124C1 BODY LOCK 3579126C1</p>								CAV	CIRCUIT	GAUGE	COLOR	TERMINAL	1	K23-G	18	TN	3518963C1	1	K23-G	18	TN	3518963C1	2	K23A1	18	TN	3518963C1	2	K23A1	18	TN	3518963C1	3	KB23	18	TN	3518963C1	3	K23	18	TN	3518963C1	4	K23B1	18	WH	3518963C1	4	K23B1	18	WH	3518963C1	5	K23C	18	TN	3518963C1	5	K23C	18	TN	3518963C1
CAV	CIRCUIT	GAUGE	COLOR	TERMINAL																																																										
1	K23-G	18	TN	3518963C1																																																										
1	K23-G	18	TN	3518963C1																																																										
2	K23A1	18	TN	3518963C1																																																										
2	K23A1	18	TN	3518963C1																																																										
3	KB23	18	TN	3518963C1																																																										
3	K23	18	TN	3518963C1																																																										
4	K23B1	18	WH	3518963C1																																																										
4	K23B1	18	WH	3518963C1																																																										
5	K23C	18	TN	3518963C1																																																										
5	K23C	18	TN	3518963C1																																																										
<p style="text-align: center;">PDM 4WAY (6566)</p> <div style="display: flex; justify-content: space-around; align-items: center;">  <table border="1" style="font-size: x-small; border-collapse: collapse;"> <thead> <tr> <th>CAV</th> <th>CIRCUIT</th> <th>GAUGE</th> <th>COLOR</th> <th>TERMINAL</th> <th>SEAL/SLEEVE</th> </tr> </thead> <tbody> <tr> <td>1</td> <td>K14J</td> <td>10</td> <td>RD</td> <td>3752553C1</td> <td>6113347C1</td> </tr> <tr> <td>3</td> <td>K14N</td> <td>10</td> <td>RD</td> <td>3752553C1</td> <td>6113347C1</td> </tr> </tbody> </table> </div> <p style="text-align: center; margin-top: 10px;">CONNECTOR 6113338C1</p>								CAV	CIRCUIT	GAUGE	COLOR	TERMINAL	SEAL/SLEEVE	1	K14J	10	RD	3752553C1	6113347C1	3	K14N	10	RD	3752553C1	6113347C1																																					
CAV	CIRCUIT	GAUGE	COLOR	TERMINAL	SEAL/SLEEVE																																																									
1	K14J	10	RD	3752553C1	6113347C1																																																									
3	K14N	10	RD	3752553C1	6113347C1																																																									
CHK	DATE	CHANGE	REV	REFERENCE	DRAWN	NAME																																																								
-	-	ADDED R/D 6400A &	D	92447S	-	CIRCUIT DIAGRAM, PROSTAR, LONESTAR																																																								
6566.					RELEASE NO.	DATE	PART NO. SHEET																																																							
					-	-	AE08058107 95A																																																							

Figure 583 Connector Body Composite (6400A), (6401), (6408), (6420), (6566)

14.175. CONNECTOR BODY COMPOSITE (7500W), (7501), (7502), (7600), (7600A), (7603), P. 98D



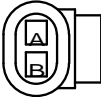
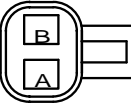

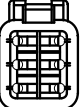
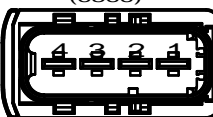
NAVISTAR, INC				ELECTRICAL CIRCUIT DIAGRAM		CHAPTER 14																																					
THIS PRINT IS PROVIDED ON A RESTRICTED BASIS AND IS NOT TO BE USED IN ANY WAY DETRIMENTAL TO THE INTEREST OF NAVISTAR, INC.				CONNECTOR BODY COMPOSITE - MATING VIEW SHOWN																																							
<p>REVERSE LIGHT (7500W) (LOCATED ON TOP OF TRANSMISSION)</p>  <table border="1" style="margin-left: auto; margin-right: auto; font-size: x-small;"> <thead> <tr> <th>CAV</th> <th>CIRC</th> <th>GAUGE</th> <th>COLOR</th> <th>TERMINAL</th> <th>SEAL/SLEEVE</th> </tr> </thead> <tbody> <tr> <td>A</td> <td>K71A</td> <td>16</td> <td>OR</td> <td>1661875C1</td> <td>1661872C1</td> </tr> <tr> <td>B</td> <td>K71B</td> <td>16</td> <td>OR</td> <td>1661875C1</td> <td>1661872C1</td> </tr> </tbody> </table> <p>CONNECTOR 1661778C1 BODY LOCK 1661874C1</p>								CAV	CIRC	GAUGE	COLOR	TERMINAL	SEAL/SLEEVE	A	K71A	16	OR	1661875C1	1661872C1	B	K71B	16	OR	1661875C1	1661872C1																		
CAV	CIRC	GAUGE	COLOR	TERMINAL	SEAL/SLEEVE																																						
A	K71A	16	OR	1661875C1	1661872C1																																						
B	K71B	16	OR	1661875C1	1661872C1																																						
<p>ECA (7501) (LOCATED ON TOP OF TRANSMISSION)</p>  <p style="text-align: right; font-size: x-small;">* W/ 2010 SCR 13L ENGINE # W/ ISX ENGINE</p> <table border="1" style="margin-left: auto; margin-right: auto; font-size: x-small;"> <thead> <tr> <th>CAV</th> <th>CIRC</th> <th>GAUGE</th> <th>COLOR</th> <th>TERMINAL</th> <th>SEAL/SLV</th> </tr> </thead> <tbody> <tr> <td>A</td> <td>PLUG</td> <td>-</td> <td>-</td> <td>1675451C1</td> <td>-</td> </tr> <tr> <td>B</td> <td>K11-G</td> <td>10</td> <td>WH</td> <td>1667737C1</td> <td>1667735C1</td> </tr> <tr> <td>C</td> <td>K14S</td> <td>10</td> <td>RD</td> <td>1667737C1</td> <td>1667735C1</td> </tr> <tr> <td>#C</td> <td>K14K</td> <td>10</td> <td>RD</td> <td>1667737C1</td> <td>1667735C1</td> </tr> <tr> <td>C*</td> <td>K14N</td> <td>10</td> <td>RD</td> <td>1667737C1</td> <td>1667735C1</td> </tr> </tbody> </table> <p>CONNECTOR 1667733C1 BODY LOCK 1667734C1</p>								CAV	CIRC	GAUGE	COLOR	TERMINAL	SEAL/SLV	A	PLUG	-	-	1675451C1	-	B	K11-G	10	WH	1667737C1	1667735C1	C	K14S	10	RD	1667737C1	1667735C1	#C	K14K	10	RD	1667737C1	1667735C1	C*	K14N	10	RD	1667737C1	1667735C1
CAV	CIRC	GAUGE	COLOR	TERMINAL	SEAL/SLV																																						
A	PLUG	-	-	1675451C1	-																																						
B	K11-G	10	WH	1667737C1	1667735C1																																						
C	K14S	10	RD	1667737C1	1667735C1																																						
#C	K14K	10	RD	1667737C1	1667735C1																																						
C*	K14N	10	RD	1667737C1	1667735C1																																						
<p>XMSN PTO (7502) (LOCATED ON TOP OF TRANSMISSION)</p>  <table border="1" style="margin-left: auto; margin-right: auto; font-size: x-small;"> <thead> <tr> <th>CAV</th> <th>CIRC</th> <th>GAUGE</th> <th>COLOR</th> <th>TERMINAL</th> <th>SEAL/SLV</th> </tr> </thead> <tbody> <tr> <td>A</td> <td>K92DP</td> <td>18</td> <td>TN</td> <td>0587578C1</td> <td>1652325C1</td> </tr> <tr> <td>B</td> <td>K92DR</td> <td>18</td> <td>TN</td> <td>0587578C1</td> <td>1652325C1</td> </tr> </tbody> </table> <p>CONNECTOR 0587567C91</p>								CAV	CIRC	GAUGE	COLOR	TERMINAL	SEAL/SLV	A	K92DP	18	TN	0587578C1	1652325C1	B	K92DR	18	TN	0587578C1	1652325C1																		
CAV	CIRC	GAUGE	COLOR	TERMINAL	SEAL/SLV																																						
A	K92DP	18	TN	0587578C1	1652325C1																																						
B	K92DR	18	TN	0587578C1	1652325C1																																						
<p>VEHICLE SPEED SENSOR (7600/7600A) (LOCATED ON TOP OF TRANSMISSION)</p>  <table border="1" style="margin-left: auto; margin-right: auto; font-size: x-small;"> <thead> <tr> <th>CAV</th> <th>CIRC</th> <th>GAUGE</th> <th>COLOR</th> <th>TERMINAL</th> <th>SEAL/SLEEVE</th> </tr> </thead> <tbody> <tr> <td>A</td> <td>K47</td> <td>18</td> <td>GY</td> <td>3554322C1</td> <td>3554318C1</td> </tr> <tr> <td>#A</td> <td>K47A</td> <td>18</td> <td>GY</td> <td>3554322C1</td> <td>3554318C1</td> </tr> <tr> <td>B</td> <td>K47A</td> <td>18</td> <td>GY</td> <td>3554322C1</td> <td>3554318C1</td> </tr> <tr> <td>#B</td> <td>K47B</td> <td>18</td> <td>GY</td> <td>3554322C1</td> <td>3554318C1</td> </tr> </tbody> </table> <p style="text-align: right; font-size: x-small;"># W/ ISX ENGINE</p> <p>CONNECTOR 3662425C1 BODY LOCK 3662518C1</p>								CAV	CIRC	GAUGE	COLOR	TERMINAL	SEAL/SLEEVE	A	K47	18	GY	3554322C1	3554318C1	#A	K47A	18	GY	3554322C1	3554318C1	B	K47A	18	GY	3554322C1	3554318C1	#B	K47B	18	GY	3554322C1	3554318C1						
CAV	CIRC	GAUGE	COLOR	TERMINAL	SEAL/SLEEVE																																						
A	K47	18	GY	3554322C1	3554318C1																																						
#A	K47A	18	GY	3554322C1	3554318C1																																						
B	K47A	18	GY	3554322C1	3554318C1																																						
#B	K47B	18	GY	3554322C1	3554318C1																																						
<p>ALLISON ENGINE SPEED SENSOR (7603)</p>  <table border="1" style="margin-left: auto; margin-right: auto; font-size: x-small;"> <thead> <tr> <th>CAV</th> <th>CIRCUIT</th> <th>GAUGE</th> <th>COLOR</th> <th>TERMINAL</th> <th>SEAL/SLEEVE</th> </tr> </thead> <tbody> <tr> <td>A</td> <td>K48#159</td> <td>18</td> <td>TN</td> <td>3554322C1</td> <td>3554318C1</td> </tr> <tr> <td>B</td> <td>K48#139</td> <td>18</td> <td>OR</td> <td>3554322C1</td> <td>3554318C1</td> </tr> </tbody> </table> <p>CONNECTOR 3610533C1 BODY LOCK 3610532C1</p>								CAV	CIRCUIT	GAUGE	COLOR	TERMINAL	SEAL/SLEEVE	A	K48#159	18	TN	3554322C1	3554318C1	B	K48#139	18	OR	3554322C1	3554318C1																		
CAV	CIRCUIT	GAUGE	COLOR	TERMINAL	SEAL/SLEEVE																																						
A	K48#159	18	TN	3554322C1	3554318C1																																						
B	K48#139	18	OR	3554322C1	3554318C1																																						
CHK	DATE	CHANGE	REV	REFERENCE	DRAWN	NAME																																					
0488	20MAY14	ADDED R/D 7603.	B	92447S	MJV0088	CIRCUIT DIAGRAM, PROSTAR, LONESTAR																																					
					RELEASE NO.	DATE	PART NO.	SHEET																																			
					92070B	25APR13	AE08058107	98D																																			

Figure 593 Connector Body Composite (7500W), (7501), (7502), (7600), (7600A), (7603)

14.185. INTENTIONALLY LEFT BLANK, P. 103

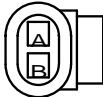
NAVISTAR, INC				ELECTRICAL CIRCUIT DIAGRAM		CHAPTER 14	
THIS PRINT IS PROVIDED ON A RESTRICTED BASIS AND IS NOT TO BE USED IN ANY WAY DETRIMENTAL TO THE INTEREST OF NAVISTAR, INC.				CONNECTOR BODY COMPOSITE - MATING VIEW SHOWN			
INTENTIONALLY LEFT BLANK							
CHK	DATE	CHANGE	REV	REFERENCE	DRAWN	NAME	
0488	20MAY14	GEOMETRY REMOVED.	C	92447S	300422	CIRCUIT DIAGRAM, PROSTAR, LONESTAR	
					RELEASE NO.	DATE	PART NO.
					61802Y	12MAR09	AE08058107
						SHEET	103

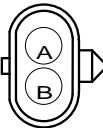
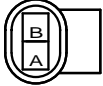
Figure 603 Intentionally Left Blank

14.195. CONNECTOR BODY COMPOSITE (8961), (8962), (8963), (8964), (8965), (8966), (8967), P. 113

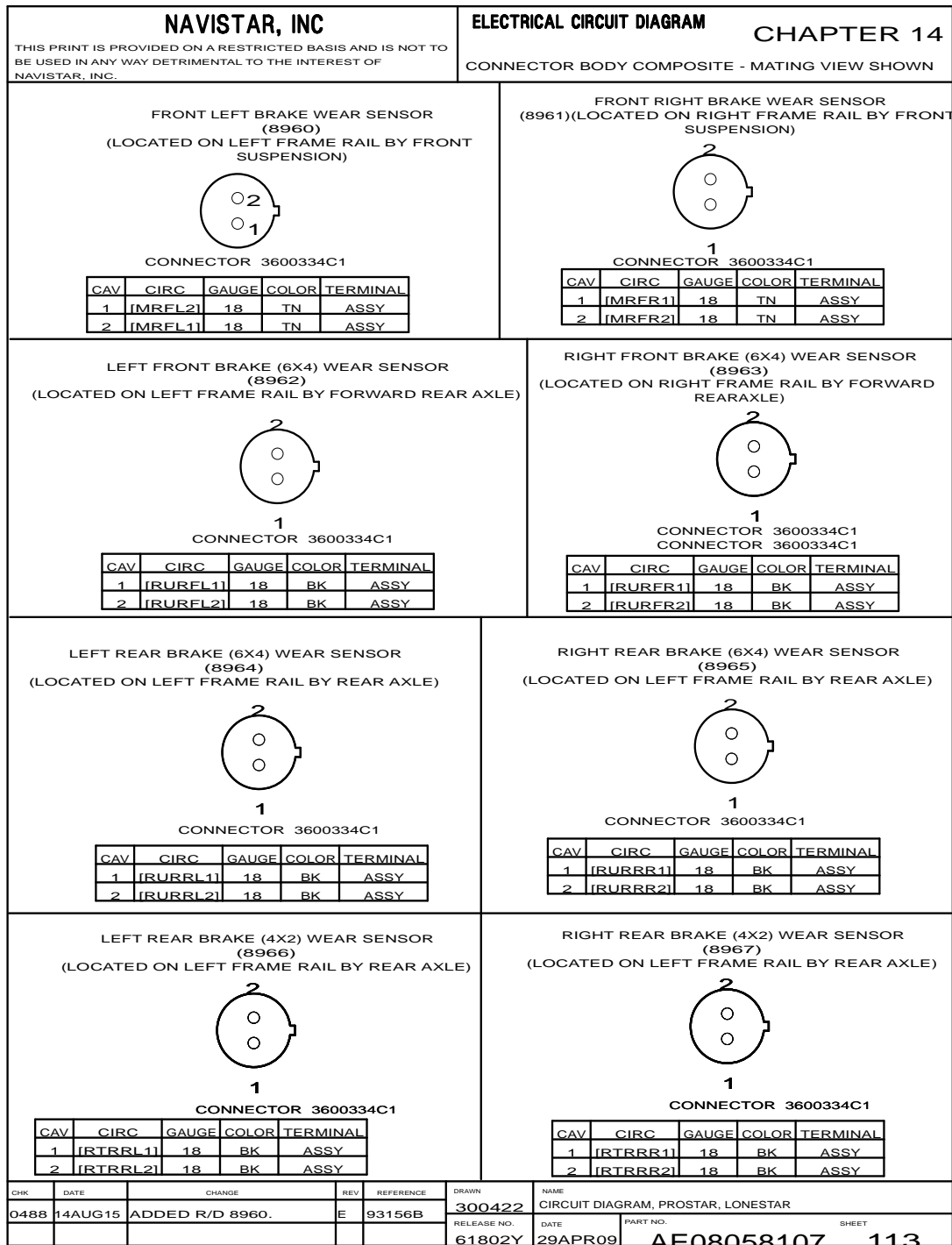

Figure 613 Connector Body Composite (8961), (8962), (8963), (8964), (8965), (8966), (8967)

14.205. CONNECTOR BODY COMPOSITE (9506), (9506D), (9506E), (9506F), (9507), (9507A), (9507C), P. 123



NAVISTAR, INC				ELECTRICAL CIRCUIT DIAGRAM				CHAPTER 14																																	
THIS PRINT IS PROVIDED ON A RESTRICTED BASIS AND IS NOT TO BE USED IN ANY WAY DETRIMENTAL TO THE INTEREST OF NAVISTAR, INC.				CONNECTOR BODY COMPOSITE - MATING VIEW SHOWN																																					
WABCO LEFT WHEEL SPEED SNSR (4X2) / WABCO RR LEFT WHEEL SPEED SNSR (6X4 HTB) (9506/9506F)																																									
				<table border="1" style="width:100%; border-collapse: collapse; font-size: x-small;"> <thead> <tr> <th>CAV</th> <th>CIRC</th> <th>GAUGE</th> <th>COLOR</th> <th>TERMINAL</th> <th>SEAL/SLV</th> </tr> </thead> <tbody> <tr> <td>1</td> <td>M94MD</td> <td>18</td> <td>GY</td> <td>6111842C1</td> <td>6111843C1</td> </tr> <tr> <td>2</td> <td>M94ME</td> <td>18</td> <td>GY</td> <td>6111842C1</td> <td>6111843C1</td> </tr> </tbody> </table>								CAV	CIRC	GAUGE	COLOR	TERMINAL	SEAL/SLV	1	M94MD	18	GY	6111842C1	6111843C1	2	M94ME	18	GY	6111842C1	6111843C1												
CAV	CIRC	GAUGE	COLOR	TERMINAL	SEAL/SLV																																				
1	M94MD	18	GY	6111842C1	6111843C1																																				
2	M94ME	18	GY	6111842C1	6111843C1																																				
CONNECTOR 6111844C1																																									
WABCO LEFT WHEEL SPEED SNSR(6X4 HAS) / WABCO LEFT WHEEL SPEED SNSR (6X4 IROS/HTB) (9506D/9506E)																																									
				<table border="1" style="width:100%; border-collapse: collapse; font-size: x-small;"> <thead> <tr> <th>CAV</th> <th>CIRC</th> <th>GAUGE</th> <th>COLOR</th> <th>TERMINAL</th> <th>SEAL/SLV</th> </tr> </thead> <tbody> <tr> <td>1</td> <td>*M94BQA</td> <td>18</td> <td>GY</td> <td>6111842C1</td> <td>6111843C1</td> </tr> <tr> <td>1</td> <td>*M94MD</td> <td>18</td> <td>GY</td> <td>6111842C1</td> <td>6111843C1</td> </tr> <tr> <td>2</td> <td>*M94BRA</td> <td>18</td> <td>GY</td> <td>6111842C1</td> <td>6111843C1</td> </tr> <tr> <td>2</td> <td>*M94ME</td> <td>18</td> <td>GY</td> <td>6111842C1</td> <td>6111843C1</td> </tr> </tbody> </table> <p style="font-size: x-small;">* MUTUALLY EXCLUSIVE</p>								CAV	CIRC	GAUGE	COLOR	TERMINAL	SEAL/SLV	1	*M94BQA	18	GY	6111842C1	6111843C1	1	*M94MD	18	GY	6111842C1	6111843C1	2	*M94BRA	18	GY	6111842C1	6111843C1	2	*M94ME	18	GY	6111842C1	6111843C1
CAV	CIRC	GAUGE	COLOR	TERMINAL	SEAL/SLV																																				
1	*M94BQA	18	GY	6111842C1	6111843C1																																				
1	*M94MD	18	GY	6111842C1	6111843C1																																				
2	*M94BRA	18	GY	6111842C1	6111843C1																																				
2	*M94ME	18	GY	6111842C1	6111843C1																																				
CONNECTOR 6111844C1																																									
WABCO RR LEFT WHEEL SPEED SENSOR (6X4 NTB) (9506F) (LOCATED ON LEFT FRAME RAIL BY REAR AXLE)																																									
				<table border="1" style="width:100%; border-collapse: collapse; font-size: x-small;"> <thead> <tr> <th>CAV</th> <th>CIRC</th> <th>GAUGE</th> <th>COLOR</th> <th>TERMINAL</th> </tr> </thead> <tbody> <tr> <td>1</td> <td>[R94MD]</td> <td>18</td> <td>GY</td> <td>ASSY</td> </tr> <tr> <td>2</td> <td>[R94ME]</td> <td>18</td> <td>GY</td> <td>ASSY</td> </tr> </tbody> </table>								CAV	CIRC	GAUGE	COLOR	TERMINAL	1	[R94MD]	18	GY	ASSY	2	[R94ME]	18	GY	ASSY															
CAV	CIRC	GAUGE	COLOR	TERMINAL																																					
1	[R94MD]	18	GY	ASSY																																					
2	[R94ME]	18	GY	ASSY																																					
CONNECTOR 6111844C1																																									
WABCO LEFT MODULATOR (9507) (LOCATED ON LEFT FRAME RAIL BY REAR AXLE)																																									
				<table border="1" style="width:100%; border-collapse: collapse; font-size: x-small;"> <thead> <tr> <th>CAV</th> <th>CIRC</th> <th>GAUGE</th> <th>COLOR</th> <th>TERMINAL</th> </tr> </thead> <tbody> <tr> <td>1</td> <td>R94MA</td> <td>18</td> <td>GY</td> <td>ASSY</td> </tr> <tr> <td>2</td> <td>R94MB</td> <td>18</td> <td>GY</td> <td>ASSY</td> </tr> <tr> <td>3</td> <td>R94MC</td> <td>18</td> <td>GY</td> <td>ASSY</td> </tr> </tbody> </table>								CAV	CIRC	GAUGE	COLOR	TERMINAL	1	R94MA	18	GY	ASSY	2	R94MB	18	GY	ASSY	3	R94MC	18	GY	ASSY										
CAV	CIRC	GAUGE	COLOR	TERMINAL																																					
1	R94MA	18	GY	ASSY																																					
2	R94MB	18	GY	ASSY																																					
3	R94MC	18	GY	ASSY																																					
CONNECTOR 3919376C1																																									
WABCO LEFT MODULATOR (4X2) / WABCO LEFT MODULATOR (6X4 HAS) / WABCO LEFT REAR MODULATOR(6X4 HTB) (9507 / 9507A / 9507C)																																									
				<table border="1" style="width:100%; border-collapse: collapse; font-size: x-small;"> <thead> <tr> <th>CAV</th> <th>CIRC</th> <th>GAUGE</th> <th>COLOR</th> <th>TERMINAL</th> <th>SEAL/SLV</th> </tr> </thead> <tbody> <tr> <td>1</td> <td>M94MA</td> <td>18</td> <td>GY</td> <td>3601686C1</td> <td>3733609C1</td> </tr> <tr> <td>2</td> <td>M94MB</td> <td>18</td> <td>GY</td> <td>3601686C1</td> <td>3733609C1</td> </tr> <tr> <td>3</td> <td>M94MC</td> <td>18</td> <td>GY</td> <td>3601686C1</td> <td>3733609C1</td> </tr> </tbody> </table>								CAV	CIRC	GAUGE	COLOR	TERMINAL	SEAL/SLV	1	M94MA	18	GY	3601686C1	3733609C1	2	M94MB	18	GY	3601686C1	3733609C1	3	M94MC	18	GY	3601686C1	3733609C1						
CAV	CIRC	GAUGE	COLOR	TERMINAL	SEAL/SLV																																				
1	M94MA	18	GY	3601686C1	3733609C1																																				
2	M94MB	18	GY	3601686C1	3733609C1																																				
3	M94MC	18	GY	3601686C1	3733609C1																																				
CONNECTOR 3919376C1																																									
CHK	DATE	CHANGE	REV	REFERENCE	DRAWN	NAME																																			
--	--	REVISED AND REDRAWN.	D	92447S	300422	CIRCUIT DIAGRAM, PROSTAR, LONESTAR																																			
					RELEASE NO.	DATE	PART NO.	SHEET																																	
					61802Y	12MAR09	AE08058107	123																																	

Figure 623 Connector Body Composite (9506), (9506D), (9506E), (9506F), (9507), (9507A), (9507C)

14.215. CONNECTOR BODY COMPOSITE (9614), (9635), (9715F), (9715M), (9716M), (9716F), P. 133

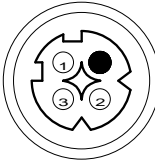
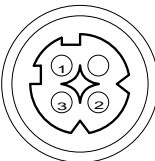
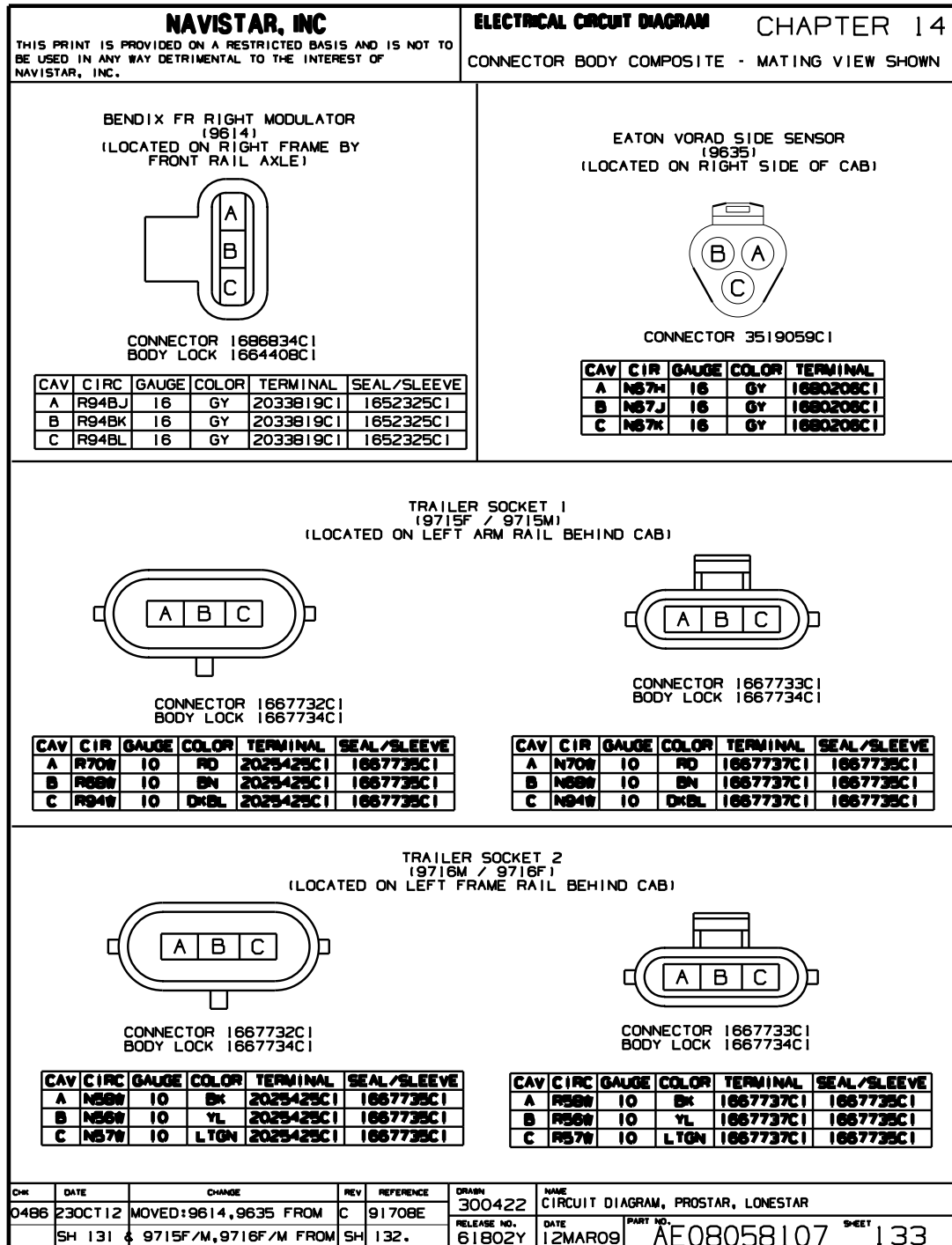

Figure 633 Connector Body Composite (9614), (9635), (9715F), (9715M), (9716M), (9716F)

CLICK HERE TO **DOWNLOAD** THE COMPLETE MANUAL

- Thank you very much for reading the preview of the manual.
- You can download the complete manual from: www.heydownloads.com by clicking the link below



- Please note: If there is no response to CLICKING the link, please download this PDF first and then click on it.

CLICK HERE TO **DOWNLOAD** THE COMPLETE MANUAL