Electrical Circuit Diagrams

3200

DuraStar® - 4100 / 4300 / 4400

WorkStar® - 7300 / 7400 / 7500 / 7600 / 7700

TranStar® - 8500 / 8600 and

RXT Models Built March 19, 2008 to May 16, 2010

Navistar, Inc.

2701 Navistar Drive, Lisle, IL 60532 USA

CLICK HERE TO **DOWNLOAD** THE COMPLETE MANUAL

- Thank you very much for reading the preview of the manual.
- You can download the complete manual from: www.heydownloads.com by clicking the link below



- Please note: If there is no response to CLICKING the link, please download this PDF first and then click on it.

CLICK HERE TO **DOWNLOAD** THE COMPLETE MANUAL

TABLE OF CONTENTS (CONT.)

13.105.CONNector COMPOSITES (7602), (7603), (7604), (7605), (7607), (7608), (7609), (7611), P. 90..... 359

13.106.CONNector COMPOSITES (7615), (7616), (7617), (7700), (7700 / @7700K), P. 91..... 360

13.107.CONNector COMPOSITES (7702), (7703), (7801F), P. 91A..... 361

13.108.CONNector COMPOSITES (7801M), (7802), (7803), (7804), (7900), (7901), P. 92..... 362

13.109.CONNector COMPOSITES (7905), (7909), P. 93..... 363

13.110.CONNector COMPOSITES (7910), (7911), P. 93A..... 364

13.111.CONNector COMPOSITES (8000), (8001), (8102), (8103), (8150), (8151), P. 94..... 365

13.112.CONNector COMPOSITES (8200), (8201), (8301), (8303), (8305), (8310), (8311), P. 95... 366

13.113.CONNector COMPOSITES (8312), (8410), (8500), (8501), P. 96..... 367

13.114.CONNector COMPOSITES (8502), (8502A), P. 96A..... 368

13.115.CONNector COMPOSITES (8503), (8503A), (8505), (8506), (8506A), (8507), (8507A), (8508), P. 97..... 369

13.116.CONNector COMPOSITES (8508A), (8509A), (8520A), (8521), (8601),\, P. 97A..... 370

13.117.CONNector COMPOSITES (8800), (8801), (8802), (8803), P. 98..... 371

13.118.CONNector COMPOSITES (8805), (8806), P. 99..... 372

13.119.CONNector COMPOSITES (8995), (8996), (8997), (8998), (8999), P. 99A..... 373

13.120.CONNector COMPOSITES (8807), (8809), (8900), (9001), P. 100..... 374

13.121.CONNector COMPOSITES (9100), (9101), (9102A / 9102), (9103), (9108), (9255), (9260), (9261), (9280), P. 101..... 375

13.122.CONNector COMPOSITES (9300), (9303), P. 102..... 376

13.123.CONNector COMPOSITES (9310), (9311), (9315), (9316), (9501), (9502), (9503), (9504), P. 103..... 377

13.124.CONNector COMPOSITES (9505), (9506), (9510), (9510A), (9510B), (9510F), (9510M), P. 104..... 378

13.125.CONNector COMPOSITE (9511), P. 105..... 379

13.126.CONNector COMPOSITES (9512), (9513), (9514), (9516), (9516A), (9517), (9517A), P. 106..... 380

13.127.CONNector COMPOSITES (9516), (9517), (9518), (9519), (9519A), (9520), (9521), (9522), (9523), (9524), P. 107..... 381

13.128.CONNector COMPOSITES (9524), (9530), P. 108..... 382

13.129.CONNector COMPOSITES (9715), (9716), P. 109..... 383

13.130.CONNector COMPOSITES (9718), (9719M), (9720), (9736), (9737), P. 110..... 384

13.131.CONNector COMPOSITES (9738), (9739), (9740 / 9740A / 9740B / 9740C), P. 111..... 385

13.132.CONNector COMPOSITES (9740), (9745), (9746), (9747), (9748), P. 112..... 386

13.133.CONNector COMPOSITES (9751), (9752), (9753), (9753A), (9754), P. 113..... 387

13.134.CONNector COMPOSITES (9758), (9759), (9760), P. 114..... 388

13.135.CONNector COMPOSITE (9761), P. 115..... 389

13.136.CONNector COMPOSITES (9761F), (9762), (9763), (9764), (9765), (9766), P. 116..... 390

13.137.CONNector COMPOSITES (9775), (9777), (9777A), (9777M), (9778), P. 117..... 391

13.138.CONNector COMPOSITES (9779F), (9780M), (9781M), (9782F), P. 118..... 392

13.139.CONNector COMPOSITES (9800), P. 119..... 393

13.140.CONNector COMPOSITES (9811), (9812), (9814), (9815), (9820M), P. 120..... 394

13.141.CONNector COMPOSITES (9830), (9832), (9900), (9900E), P. 121..... 395

13.142.CONNector COMPOSITES (9913B), (9915), (9920), (9921), (9994), (9999), P. 122..... 396

2.9. SCHEMATIC SYMBOL CHART, P. 9



INTERNATIONAL TRUCK AND ENGINE CORPORATION THIS PRINT IS PROVIDED ON A RESTRICTED BASIS AND IS NOT TO BE USED IN ANY WAY DETRIMENTAL TO THE INTEREST OF INTERNATIONAL TRUCK AND ENGINE CORPORATION.					ELECTRICAL CIRCUIT DIAGRAM CHAPTER 2 SCHEMATIC SYMBOL CHART		
SYMBOL		DESCRIPTION		SYMBOL		DESCRIPTION	
		ACCEL PEDAL POSN SENSOR				AMMETER	
		ACCEL PEDAL POSN SENSOR				BATTERY	
		AIR DRYER				BLUNT CUT CIRCUIT	
		ALARM				BUSBAR	
		ALTERNATOR				CIGAR LIGHTER	
				TYPE 1 TYPE 2 OR 3		CIRCUIT BREAKER	
							
						DIODE	
CHK	DATE	CHANGE	REV	REFERENCE	DRAWN	NAME	
CNA	BMAY07	ADDED SYMBOL FOR	A	60782A	U00K640	42/43/44/85/8600 & 73/74/7500 CIRC DIAGRAMS	
		ACCEL PEDAL POSN SNSR			RELEASE NO.	DATE	PART NO.
					59974G	12SEP06	AE08-56608
							SHEET 09

Figure 9 Schematic Symbol Chart

3.7. IGNITION FEED RELAY 2, P. 7

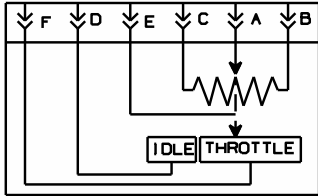
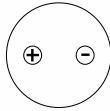
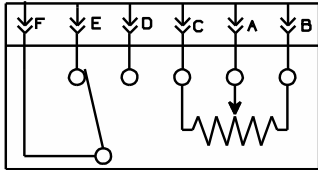
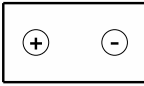
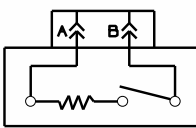
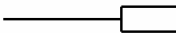
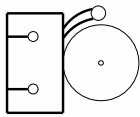
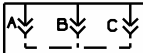
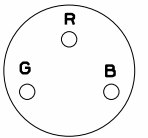
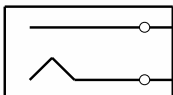
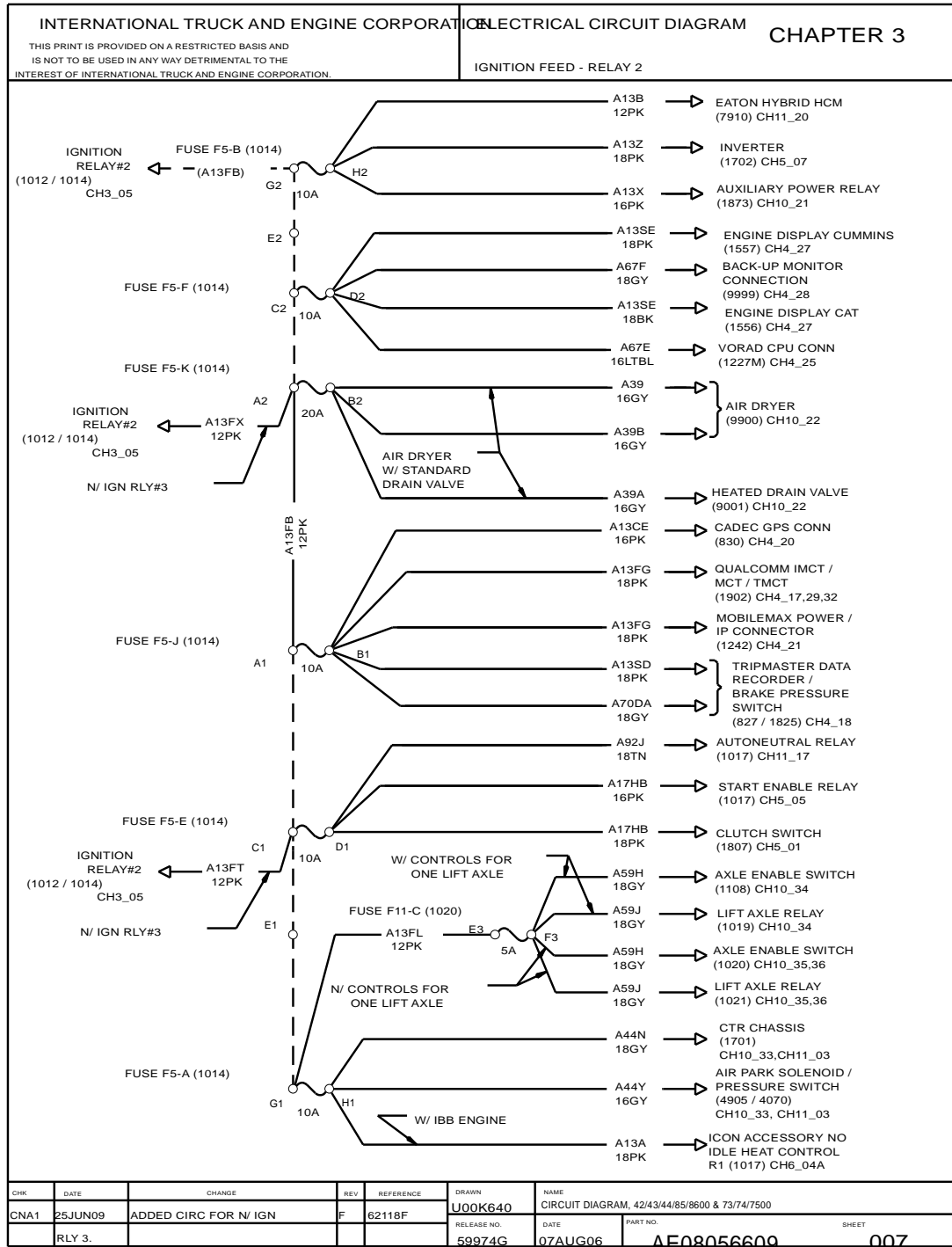

Figure 19 Ignition Feed Relay 2

3.17. J1939 DATA LINK – C11 / C13 2007 ENGINE, P. 17

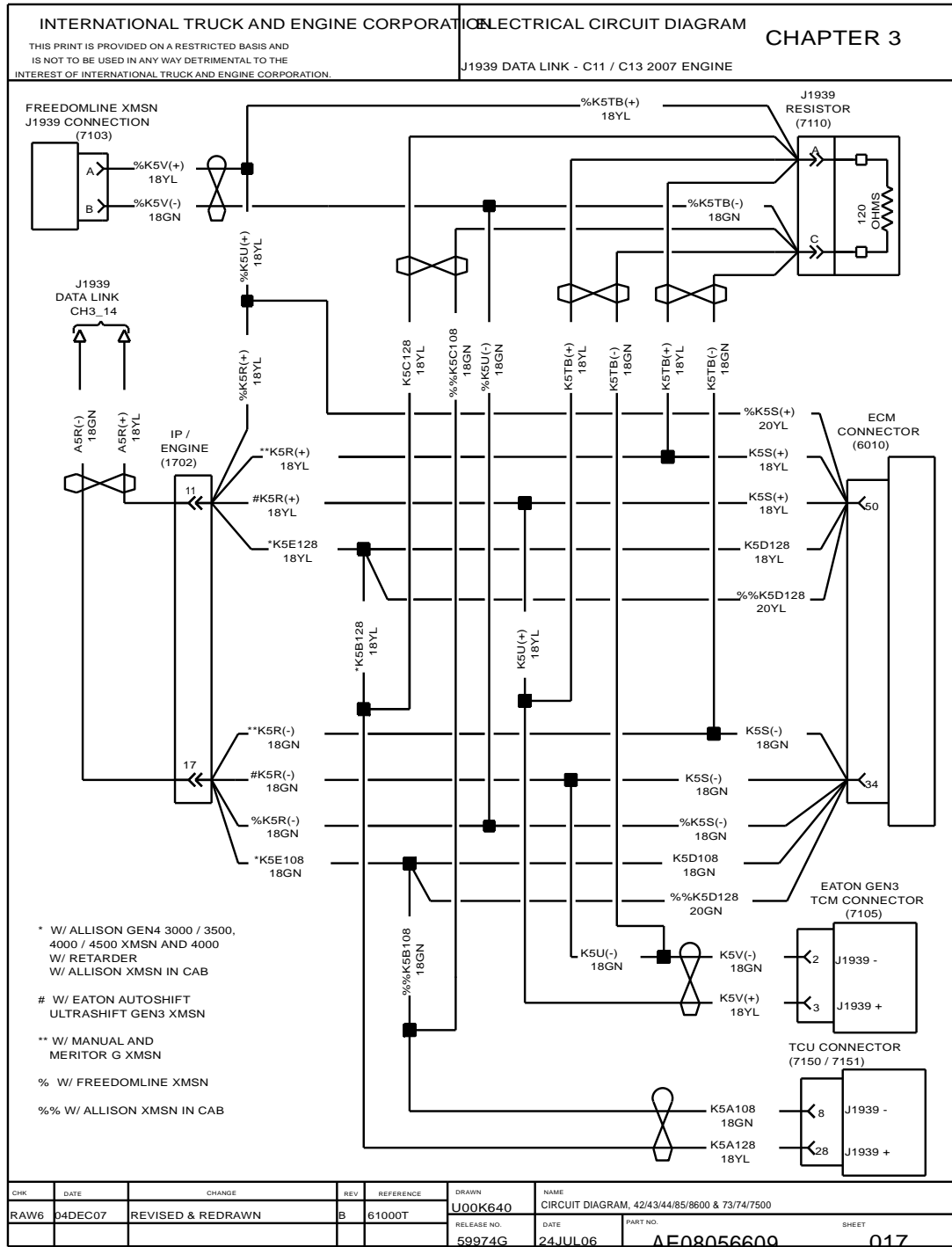

Figure 29 J1939 Data Link – C11 / C13 2007 Engine

3.27. GROUND – CHASSIS (CONT.), P. 27

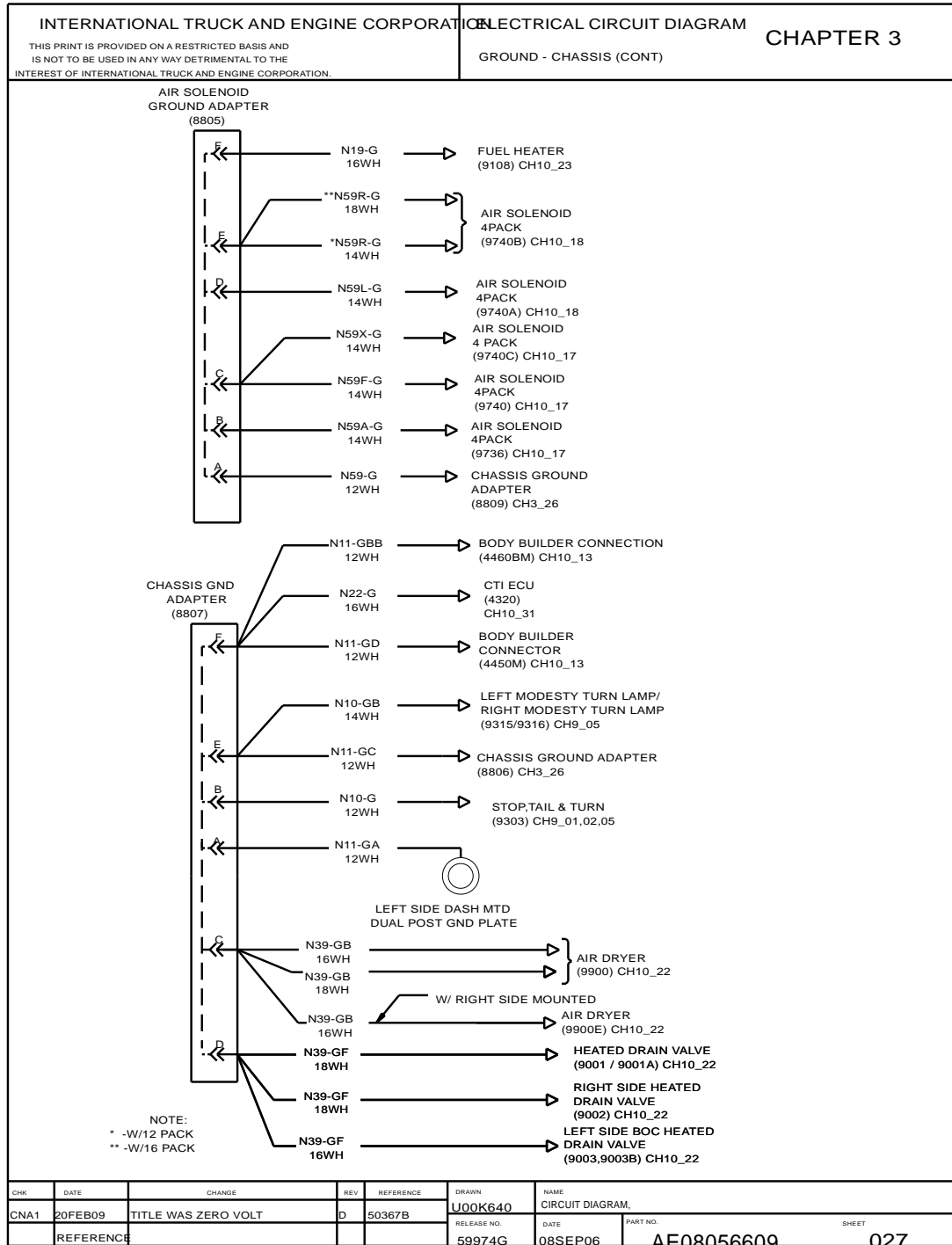

Figure 39 Ground – Chassis (Cont.)

CAB ACCESSORIES (CHAPTER 4)

4.1. CIGAR LIGHTER AND POWER FEED, P. 1

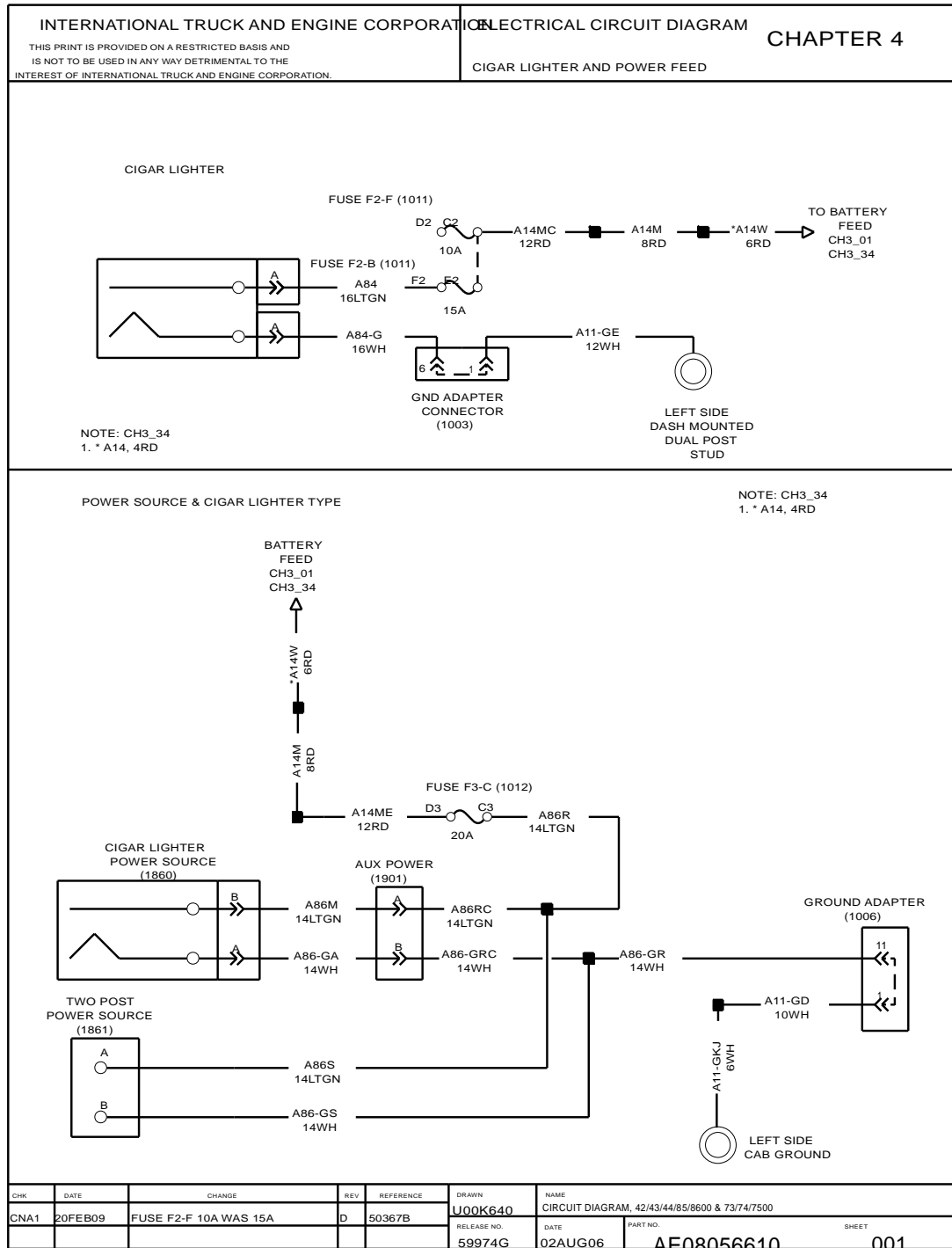

Figure 49 Cigar Lighter and Power Feed

4.11. DUAL HEATED MOTORIZED MIRRORS WITH HEATED WINDSHIELD, WITHOUT HYD FPB, P. 9B

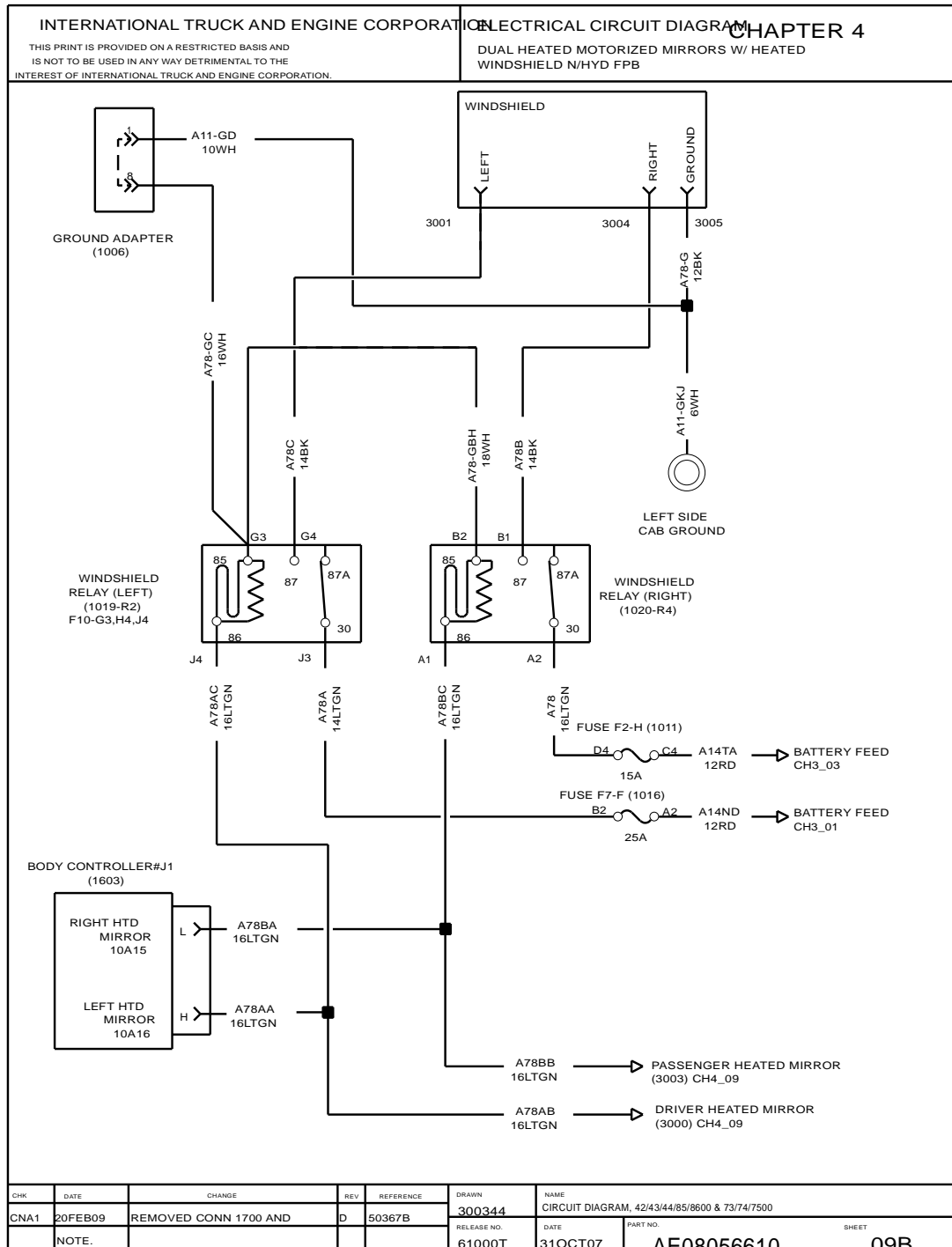

Figure 59 Dual Heated Motorized Mirrors with Heated Windshield, without Hyd FPB

4.21. SATELLITE COMMUNICATION – TRIPMASTER, P. 18

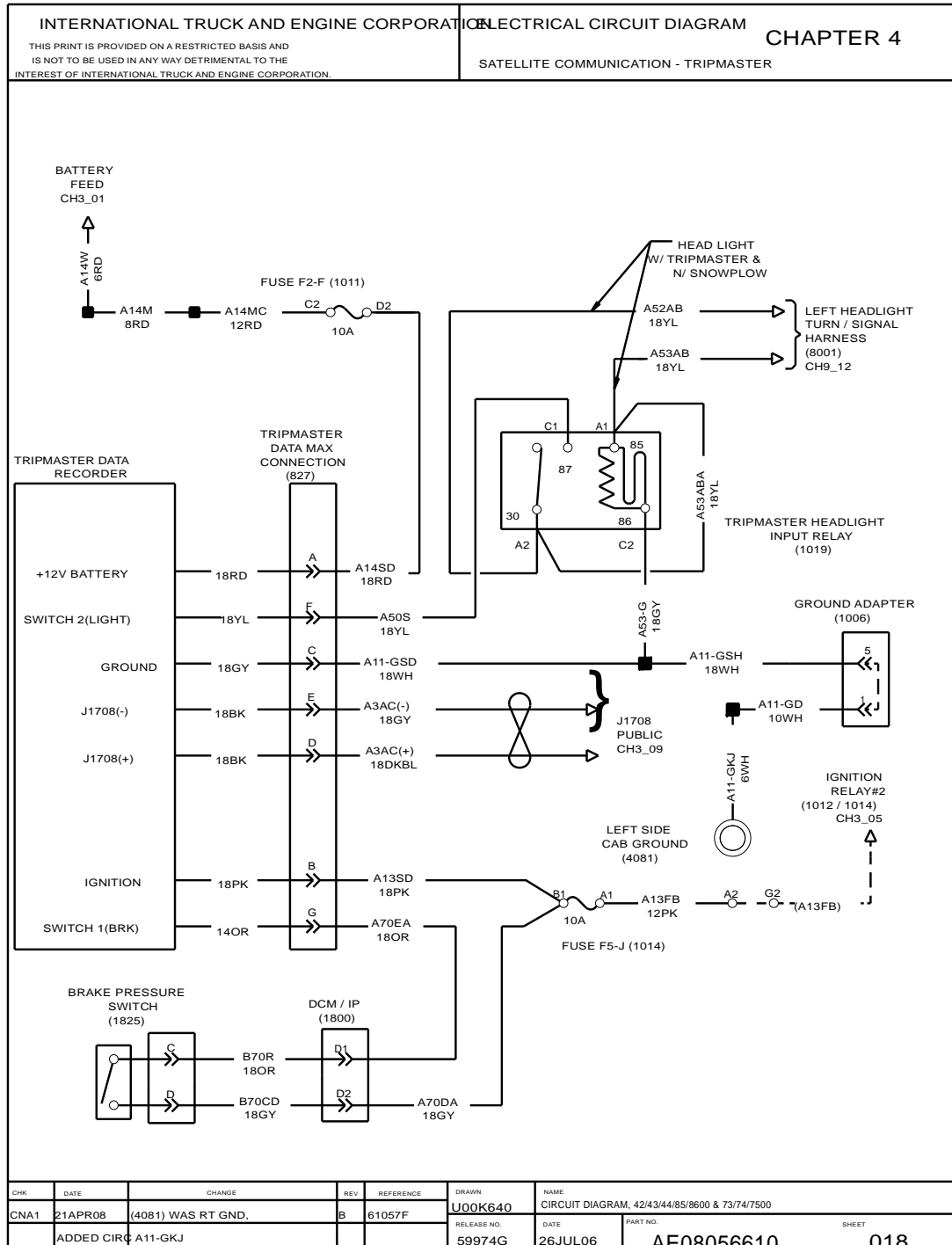

Figure 69 Satellite Communication – Tripmaster

4.31. BACK-UP CAMERA, P. 28

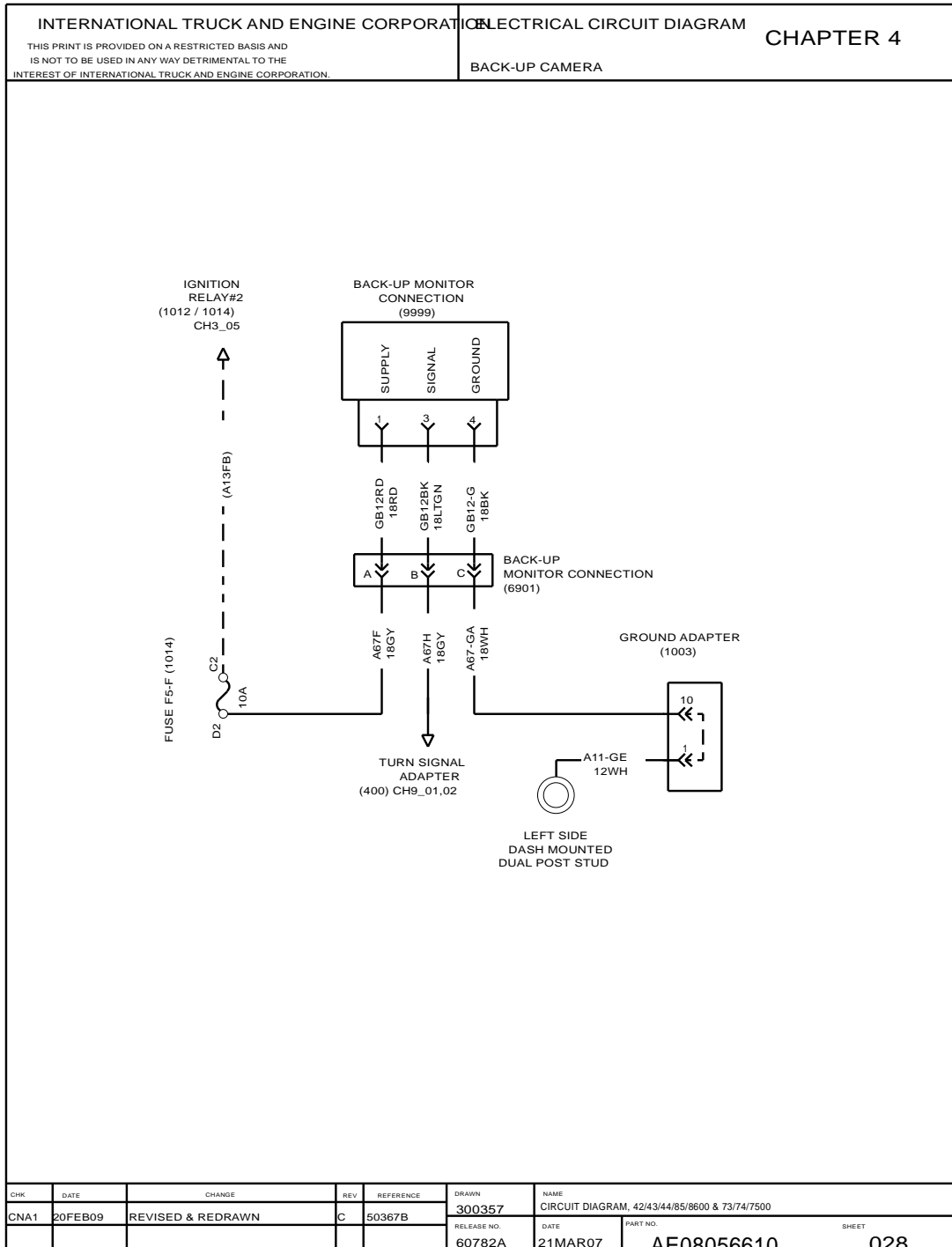

Figure 79 Back-Up Camera

CHK	DATE	CHANGE	REV	REFERENCE	DRAWN	NAME
CNA1	20FEB09	REVISED & REDRAWN	C	50367B	300357	CIRCUIT DIAGRAM, 42/43/44/85/8600 & 73/74/7500
					RELEASE NO. 60782A	DATE 21MAR07
						PART NO. AE08056610
						SHEET 028

5.2. STARTING AND CRANKING CAT WITH EURO IV ISM ENGINE & IBB ENGINE WITH MANUAL TRANSMISSION, P. 2

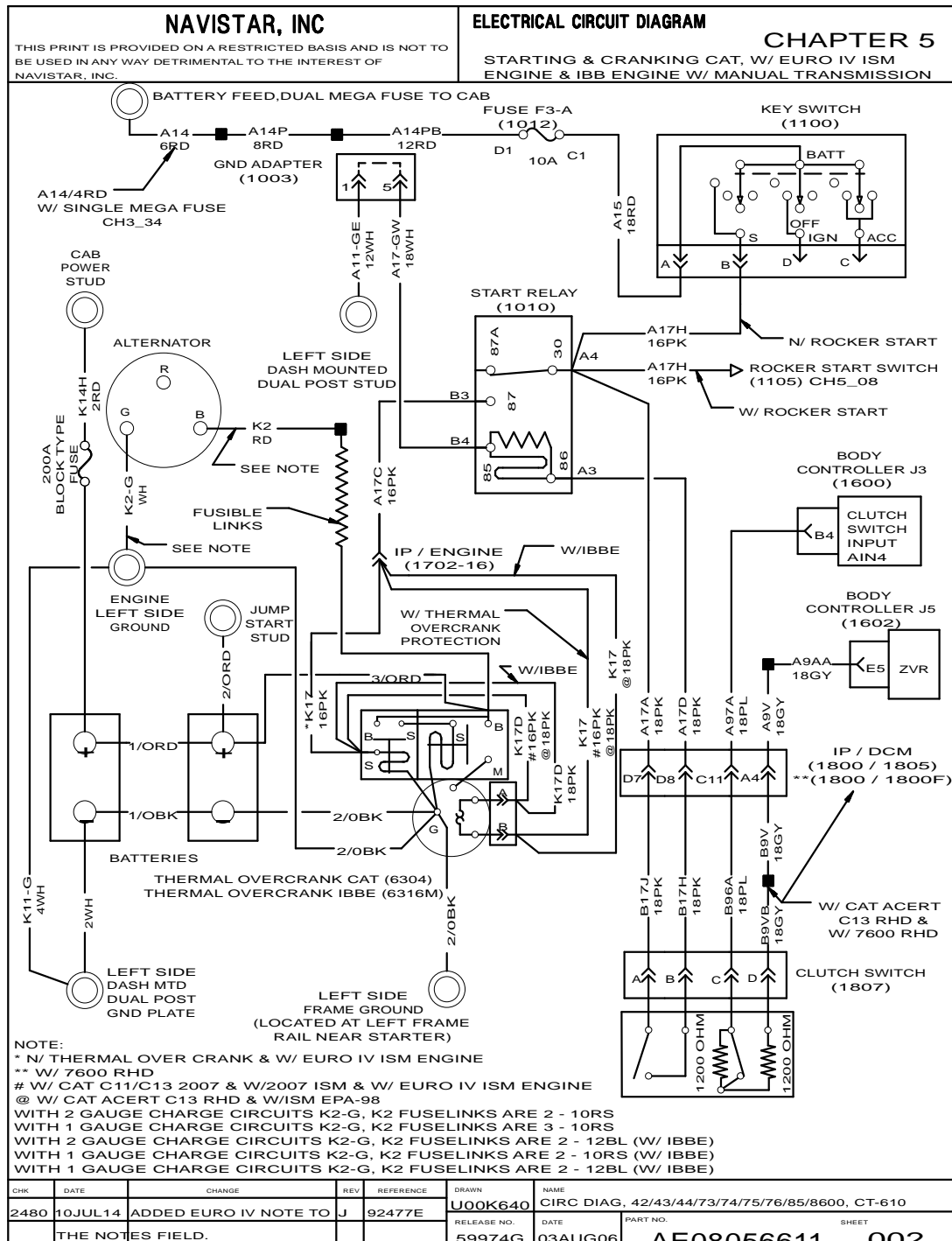

Figure 89 Starting and Cranking Cat with Euro IV ISM Engine & IBB Engine with Manual Transmission

6.4. SNOW VALVE, P. 4

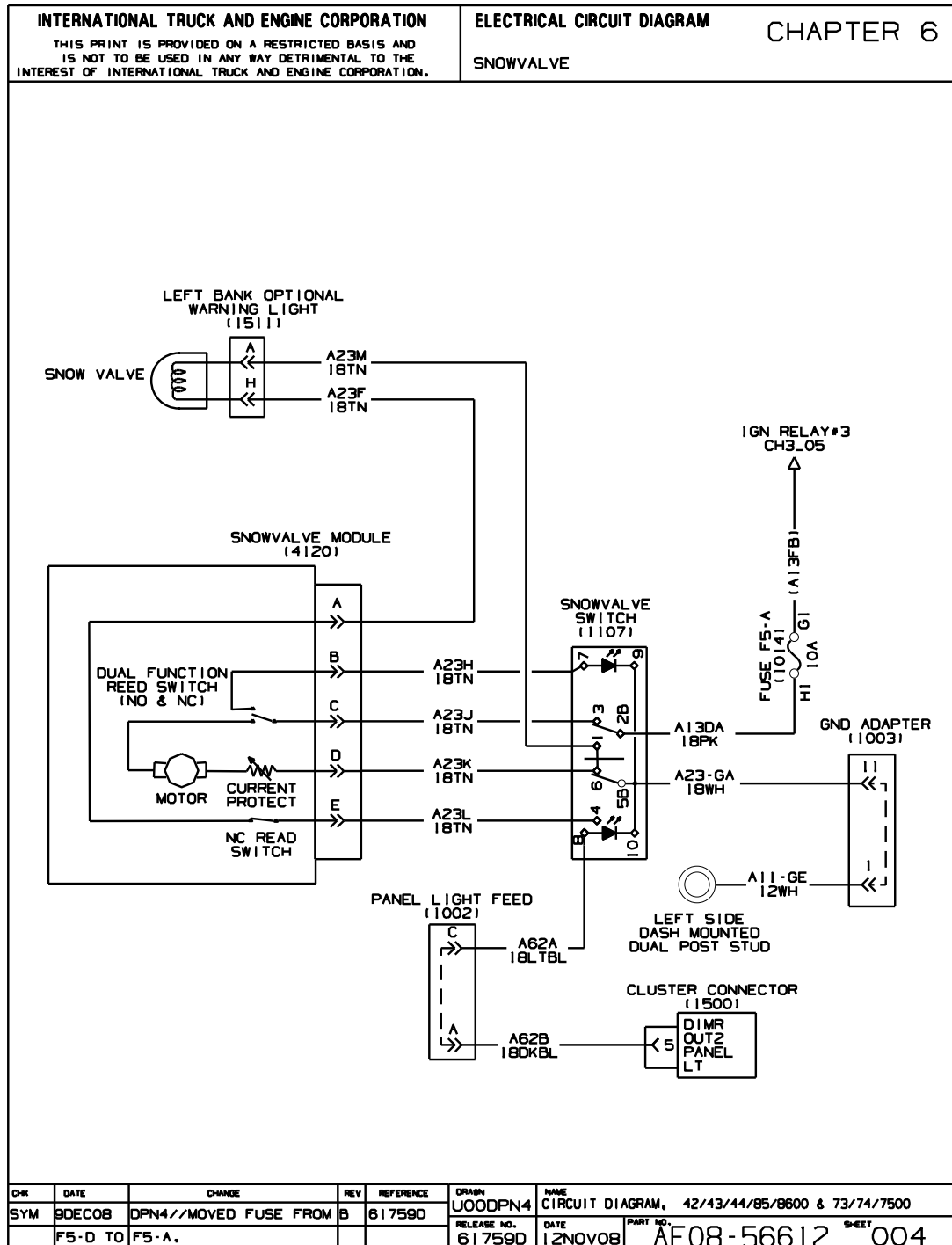

Figure 99 Snow Valve

7.7. ELECTRONIC ENGINE CONTROLS (EURO IV ISM ENGINE), P. 6A

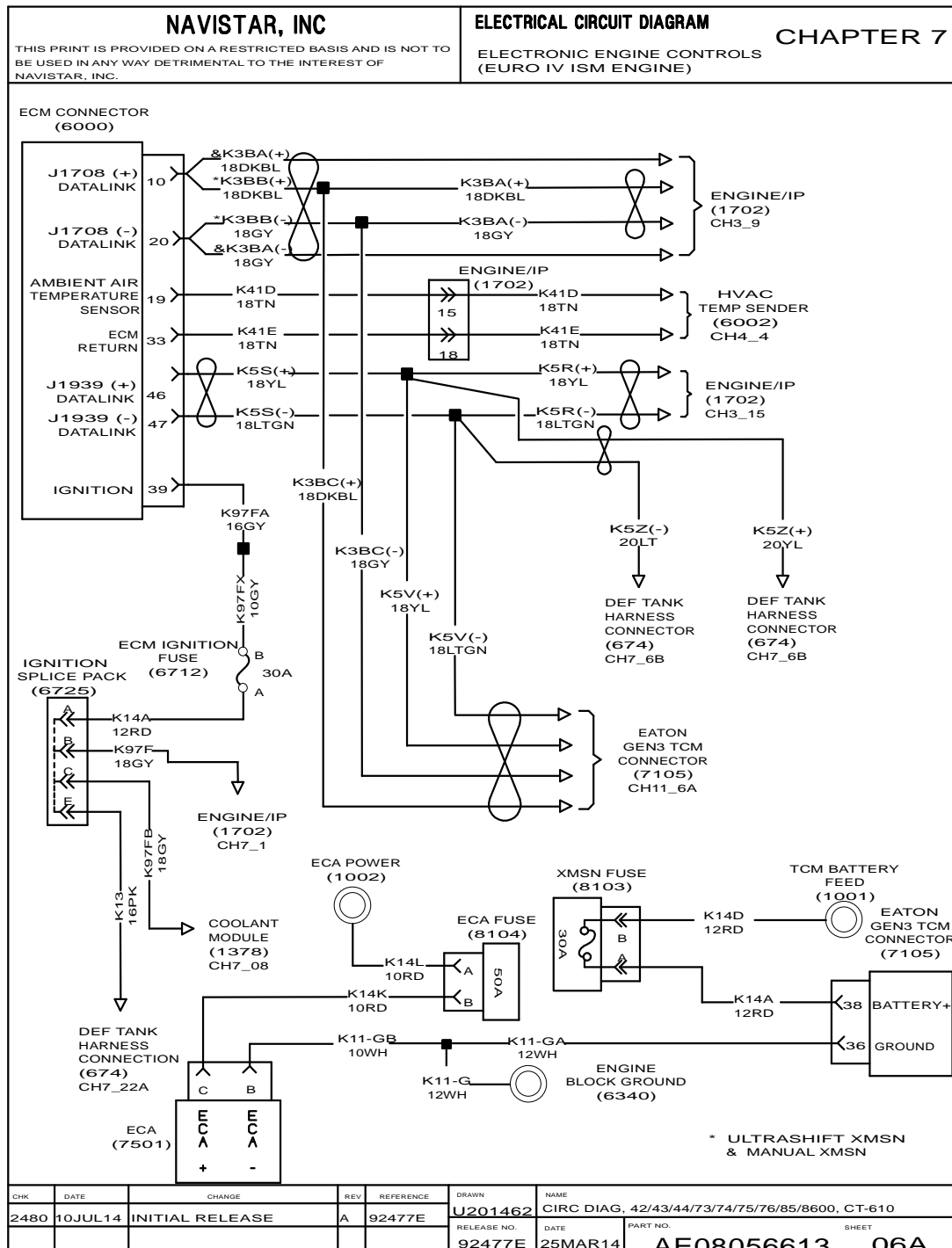

Figure 109 Electronic Engine Controls, (Euro IV ISM Engine)

7.17. CRUISE CONTROL, P. 15

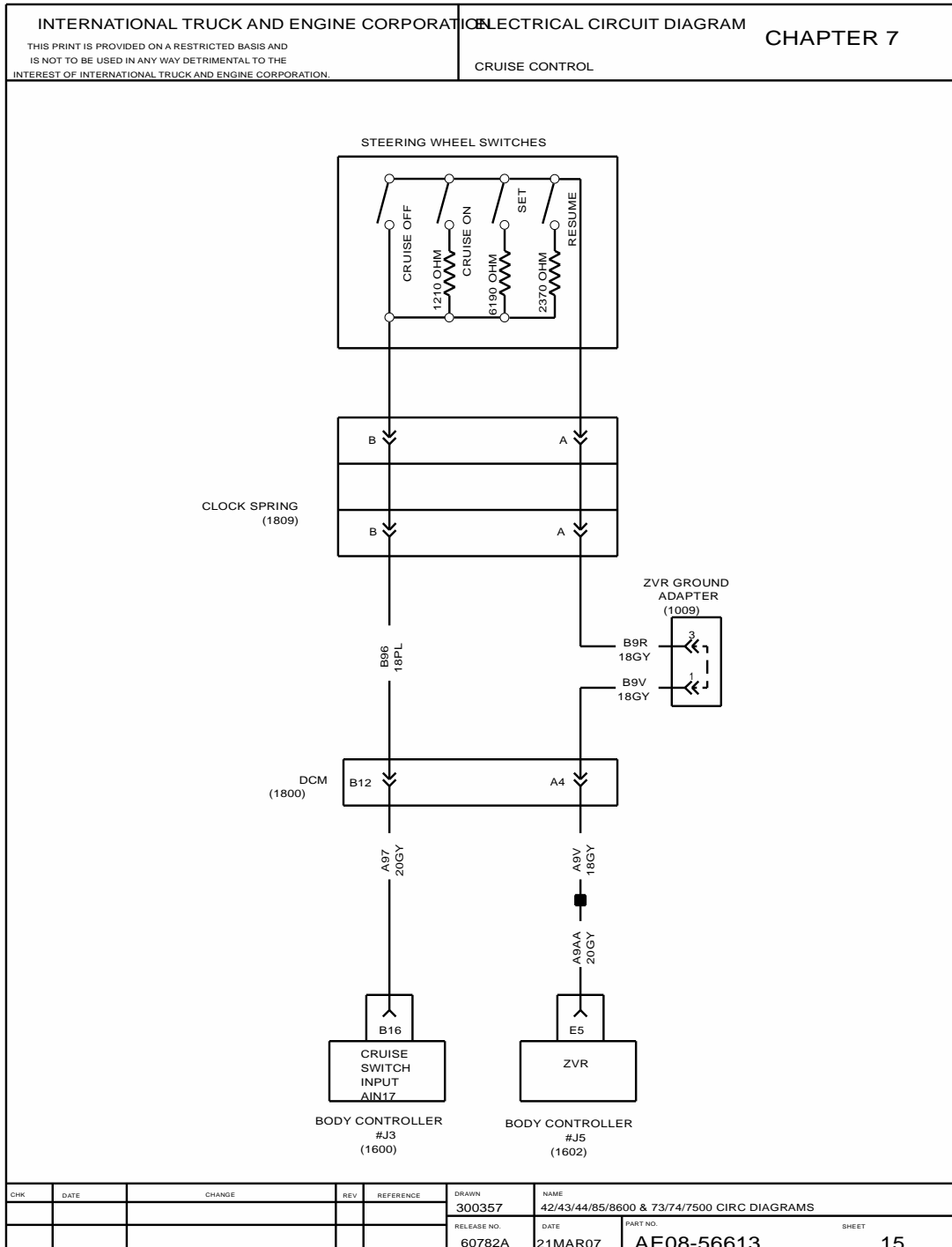

Figure 119 Cruise Control

7.27. AFTERTREATMENT (ISM 2007 & EURO IV ISM ENGINE), P. 22B

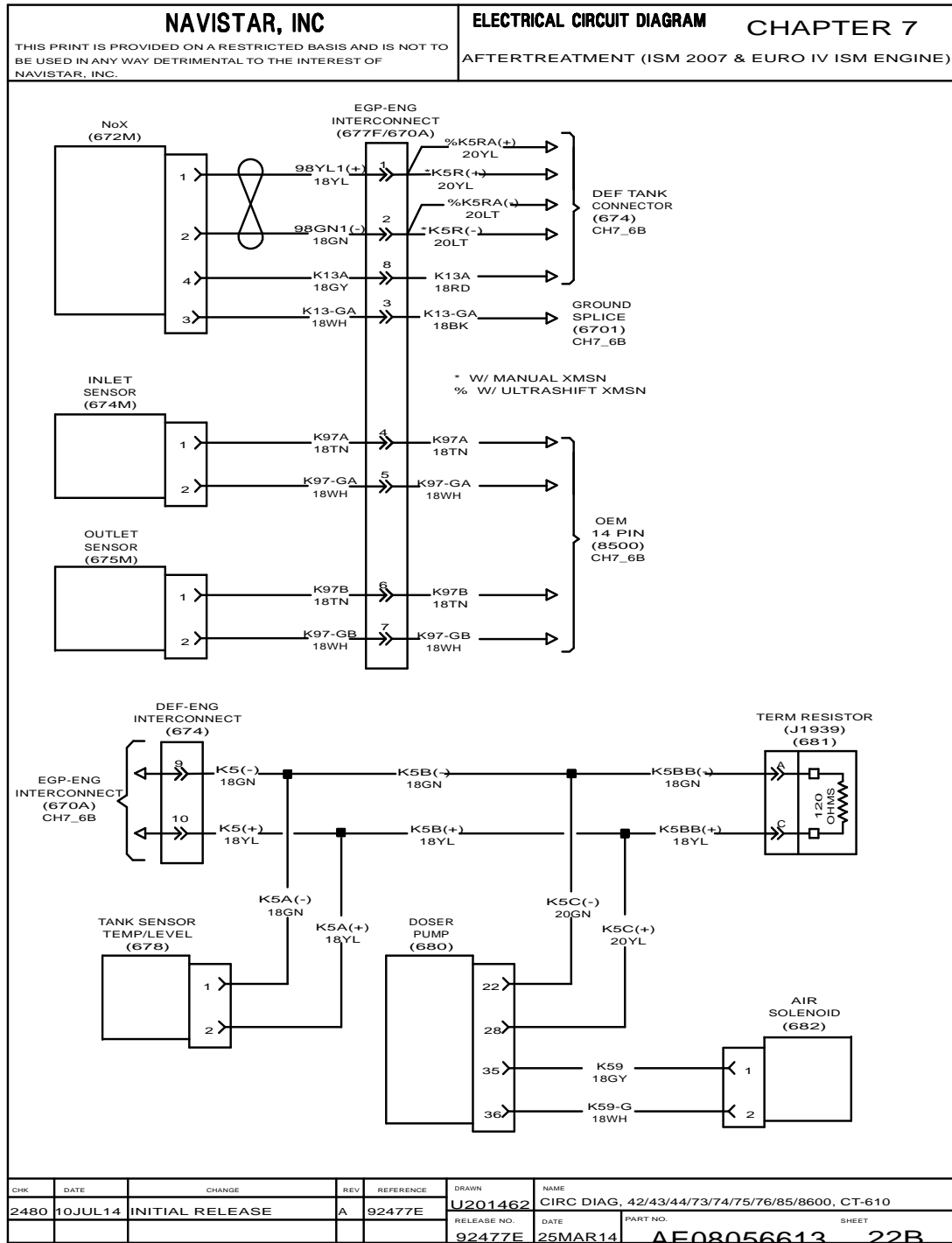

Figure 129 Aftertreatment (ISM 2007 & Euro IV ISM Engine)

8.10. PARK BRAKE SWITCH HYDRAULIC, P. 9A

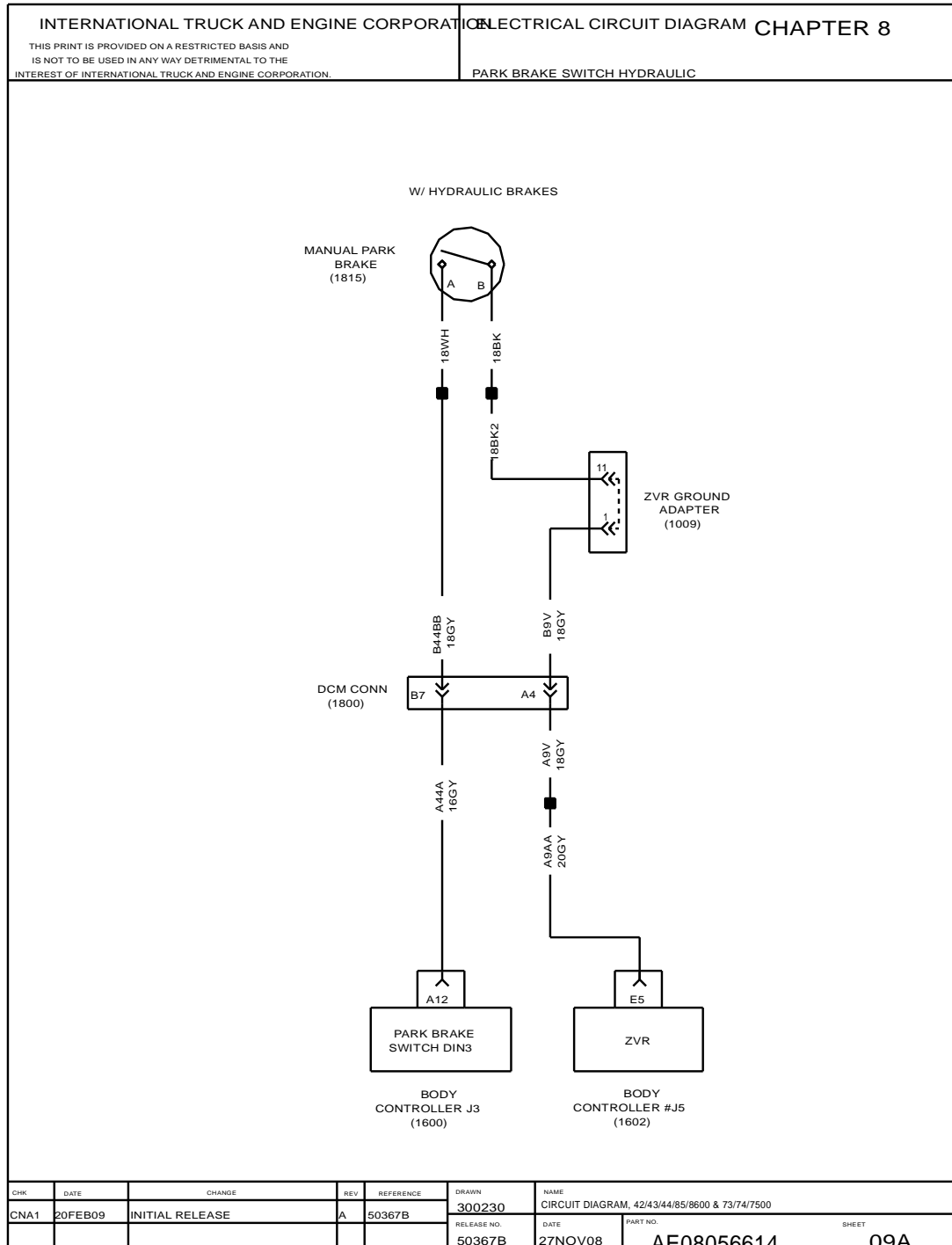

Figure 139 Park Brake Switch Hydraulic

9.2. BACK-UP LIGHTS WITH ALLISON TRANSMISSION, P. 2

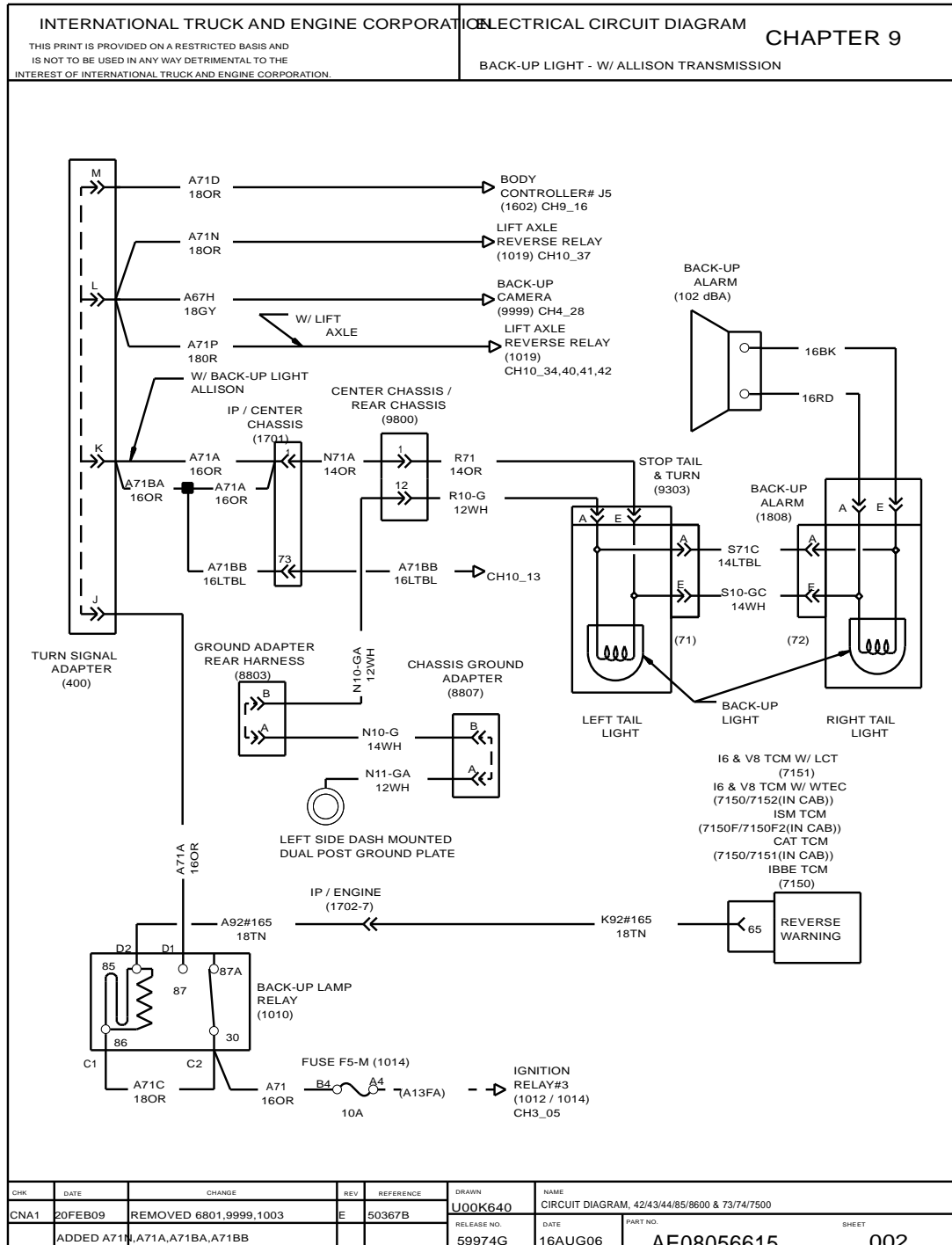

Figure 149 Back-Up Lights with Allison Transmission

9.12. HEADLIGHTS, P. 12

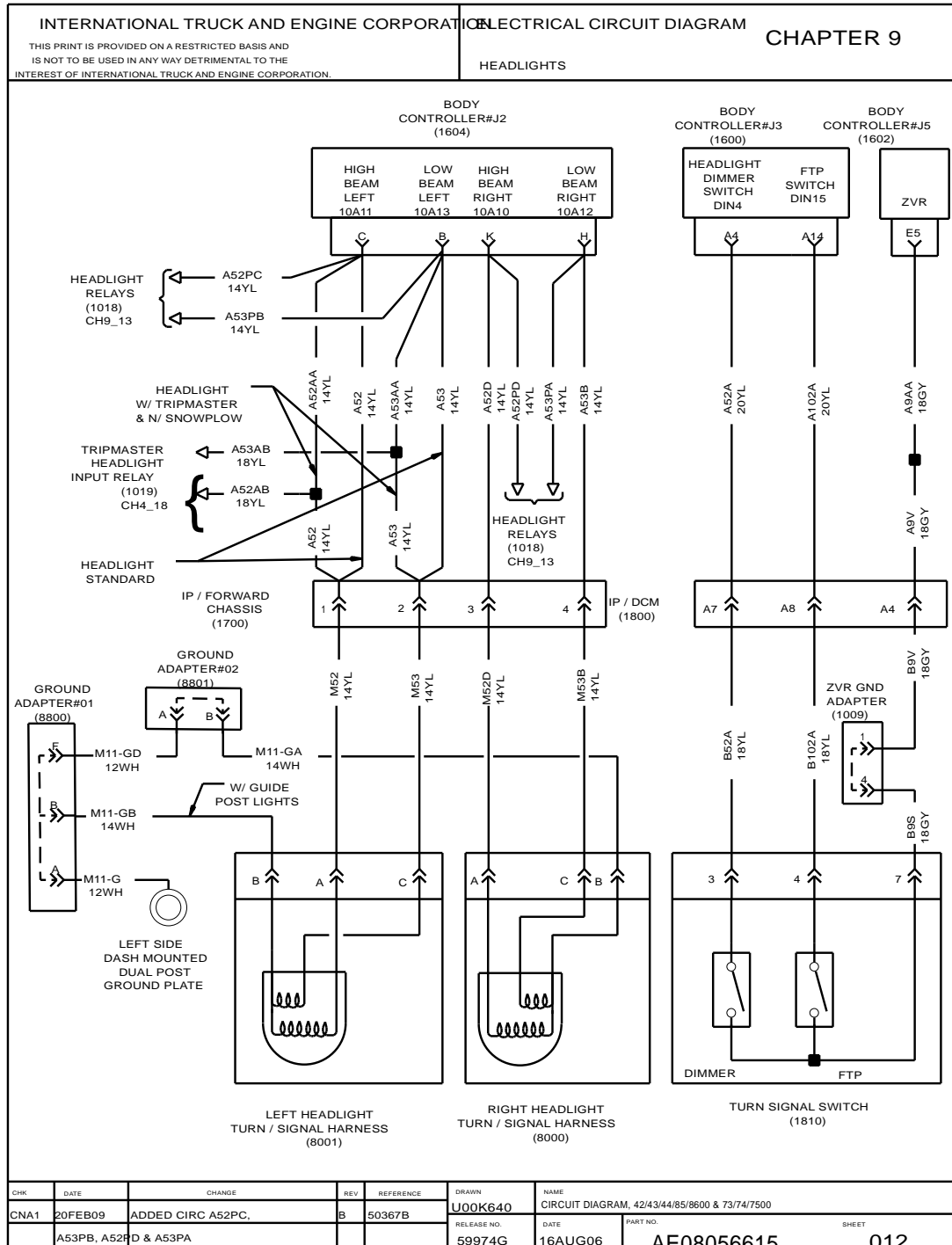

Figure 159 Headlights

10.6. ABS – WABCO AIR (8000 MODELS) (CONT.), P. 5

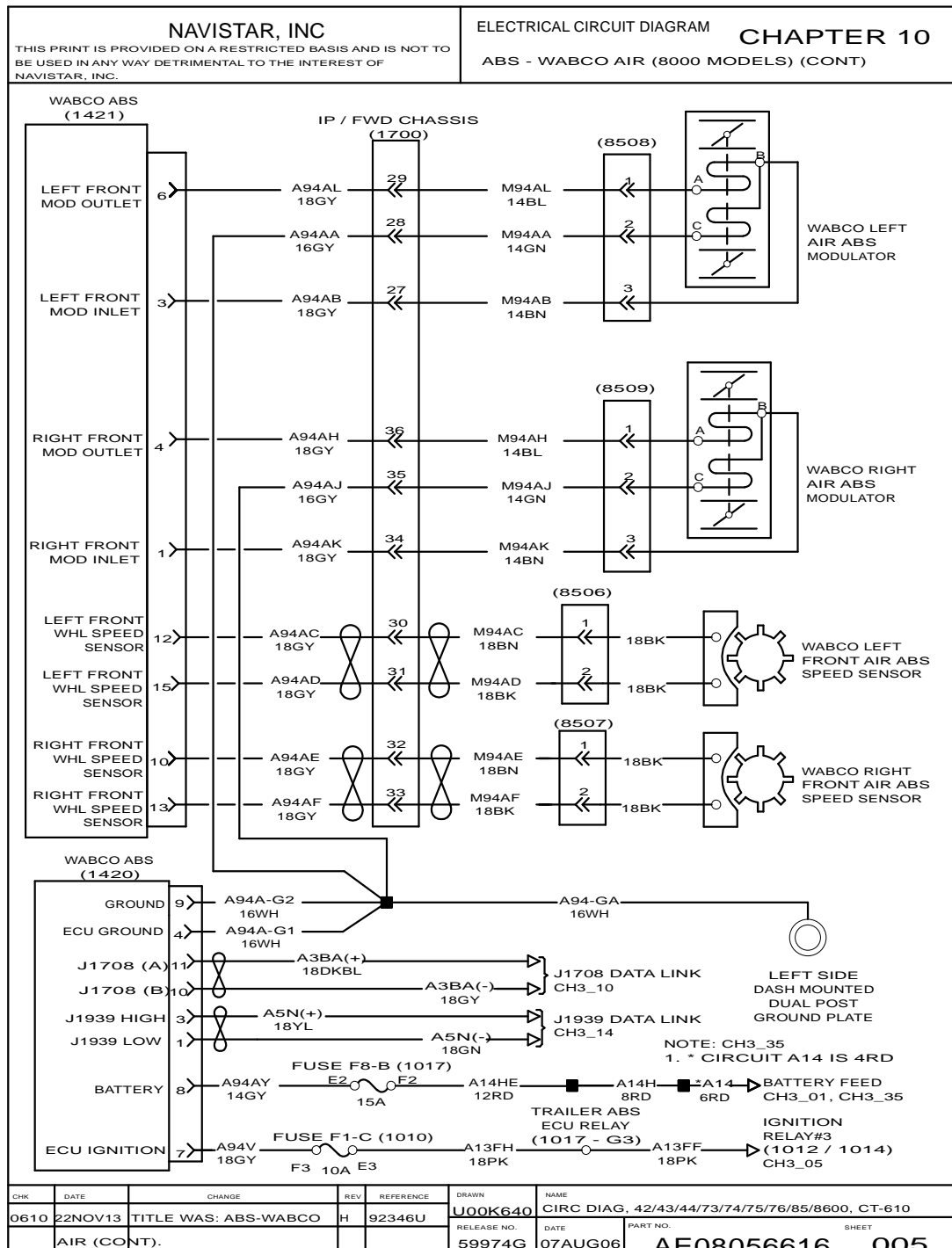

Figure 169 ABS – Wabco Air (8000 Models) (Cont.)

10.16. BODY BUILDER CONNECTIONS, P. 13

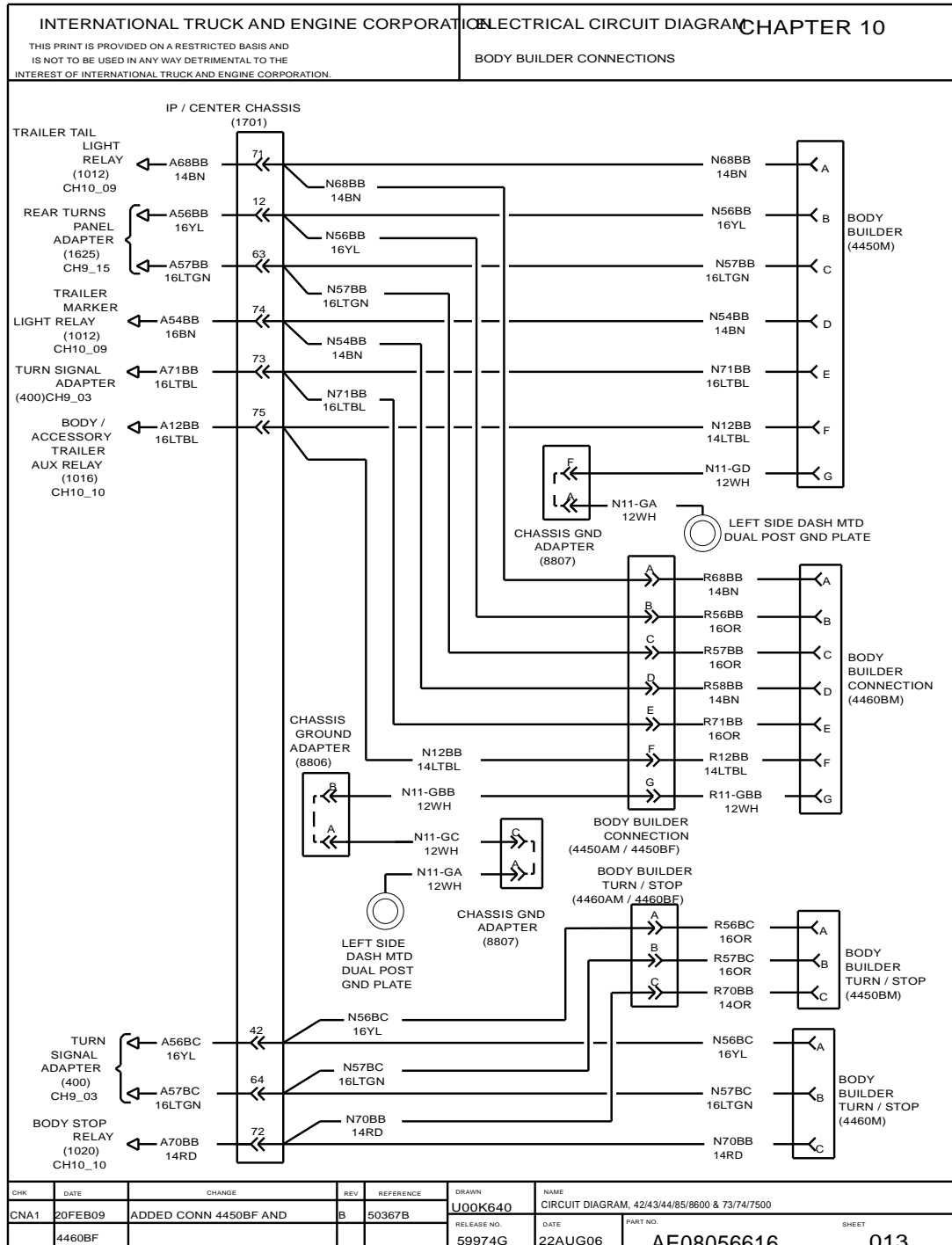

Figure 179 Body Builder Connections

CLICK HERE TO **DOWNLOAD** THE COMPLETE MANUAL

- Thank you very much for reading the preview of the manual.
- You can download the complete manual from: www.heydownloads.com by clicking the link below



- Please note: If there is no response to CLICKING the link, please download this PDF first and then click on it.

CLICK HERE TO **DOWNLOAD** THE COMPLETE MANUAL

10.26. BLANK PAGE, P. 20

INTERNATIONAL TRUCK AND ENGINE CORPORATION					ELECTRICAL CIRCUIT DIAGRAM					CHAPTER 10	
THIS PRINT IS PROVIDED ON A RESTRICTED BASIS AND IS NOT TO BE USED IN ANY WAY DETRIMENTAL TO THE INTEREST OF INTERNATIONAL TRUCK AND ENGINE CORPORATION.											
INTENTIONALLY LEFT BLANK											
CHK	DATE	CHANGE	REV	REFERENCE	DRAWN	NAME					
					U00K640	42/43/44/85/8600 & 73/74/7500 CIRC DIAGRAMS					
					RELEASE NO.	DATE	PART NO.	SHEET			
					59974G	20APR06	AF08-56616				20

Figure 189 Blank page

10.36. BLANK PAGE, P. 30

INTERNATIONAL TRUCK AND ENGINE CORPORATION				ELECTRICAL CIRCUIT DIAGRAM CHAPTER 10			
THIS PRINT IS PROVIDED ON A RESTRICTED BASIS AND IS NOT TO BE USED IN ANY WAY DETRIMENTAL TO THE INTEREST OF INTERNATIONAL TRUCK AND ENGINE CORPORATION.							
<p>INTENTIONALLY LEFT BLANK</p>							
CHK	DATE	CHANGE	REV	REFERENCE	DRAWN	NAME	
CNA1	20FEB09	REMOVED GEOMETRY	B	50367B	U00K640	CIRCUIT DIAGRAM, 42/43/44/85/8600 & 73/74/7500	
					RELEASE NO.	DATE	PART NO.
					59974G	07AUG06	AE08056616
						SHEET	030

Figure 199 Blank Page

10.46. ABS – BENDIX AIR 6S / 6M (CONT.), P. 39

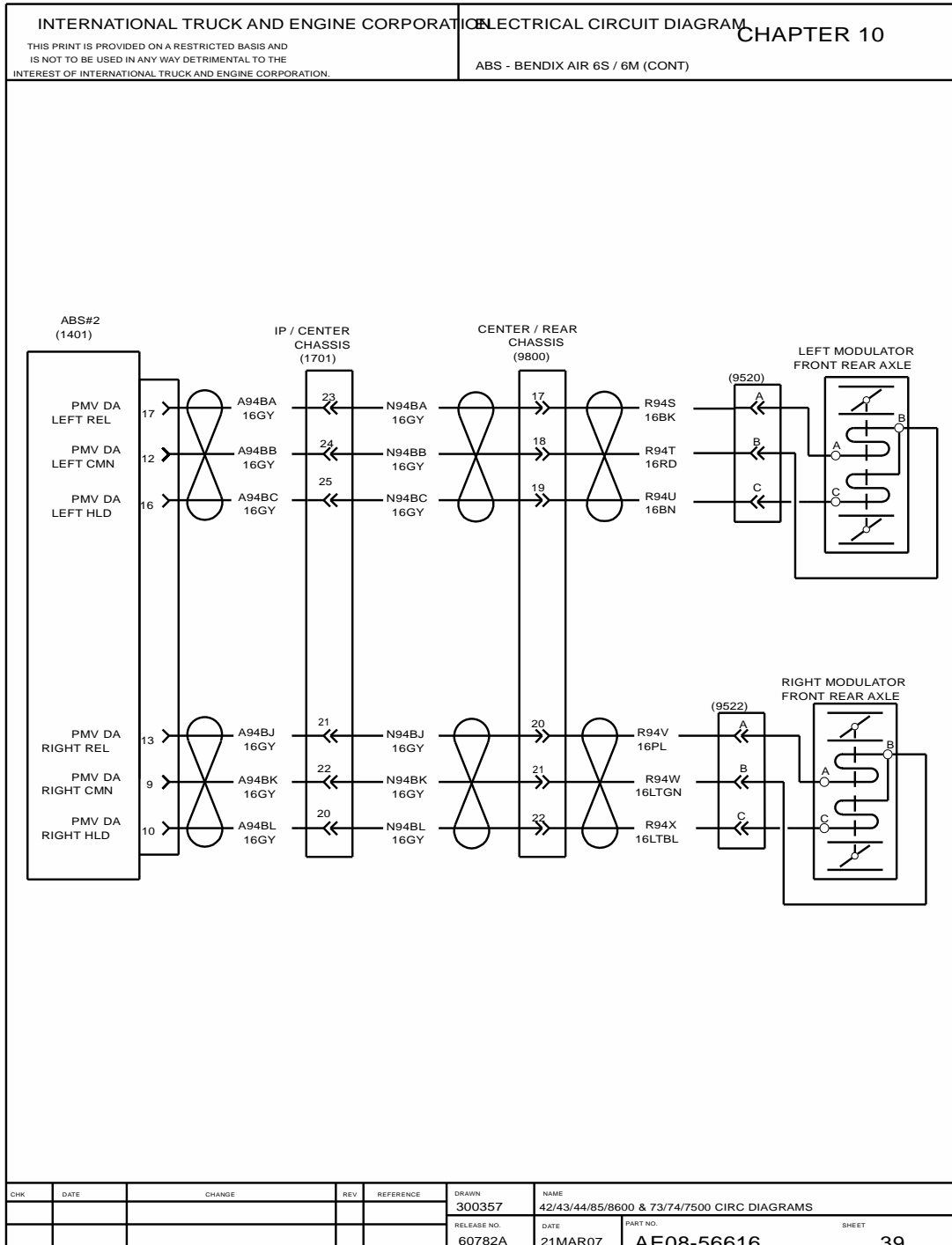

11.5. TRANSMISSION, ALLISON MD 3 / 4000 WITH I6 AND WITH V8 ENGINE, P. 5

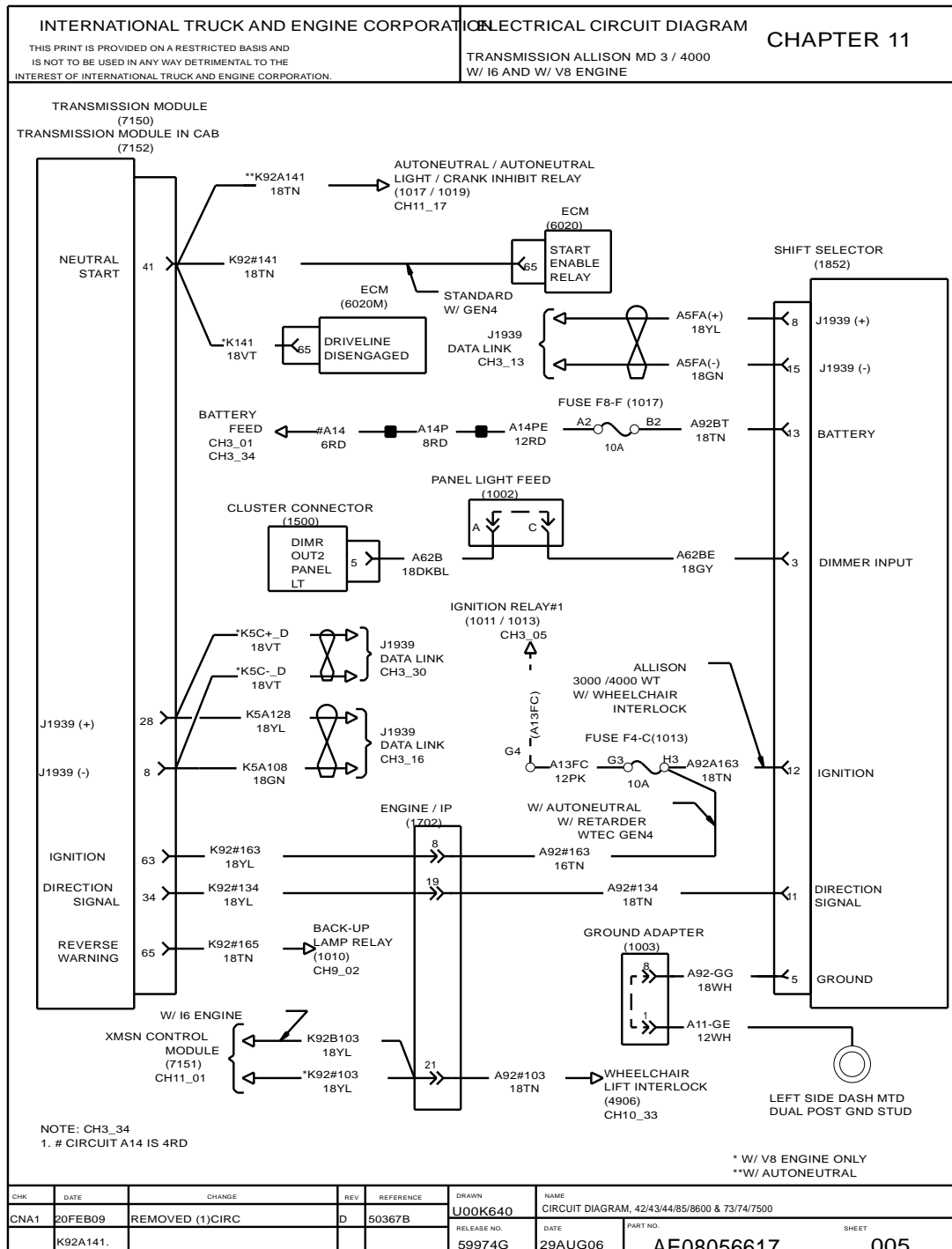

Figure 219 Transmission, Allison MD 3 / 4000 with I6 and with V8 Engine

11.15. EATON AUTOSHIFT TRANSMISSION (CONT.), P. 12A

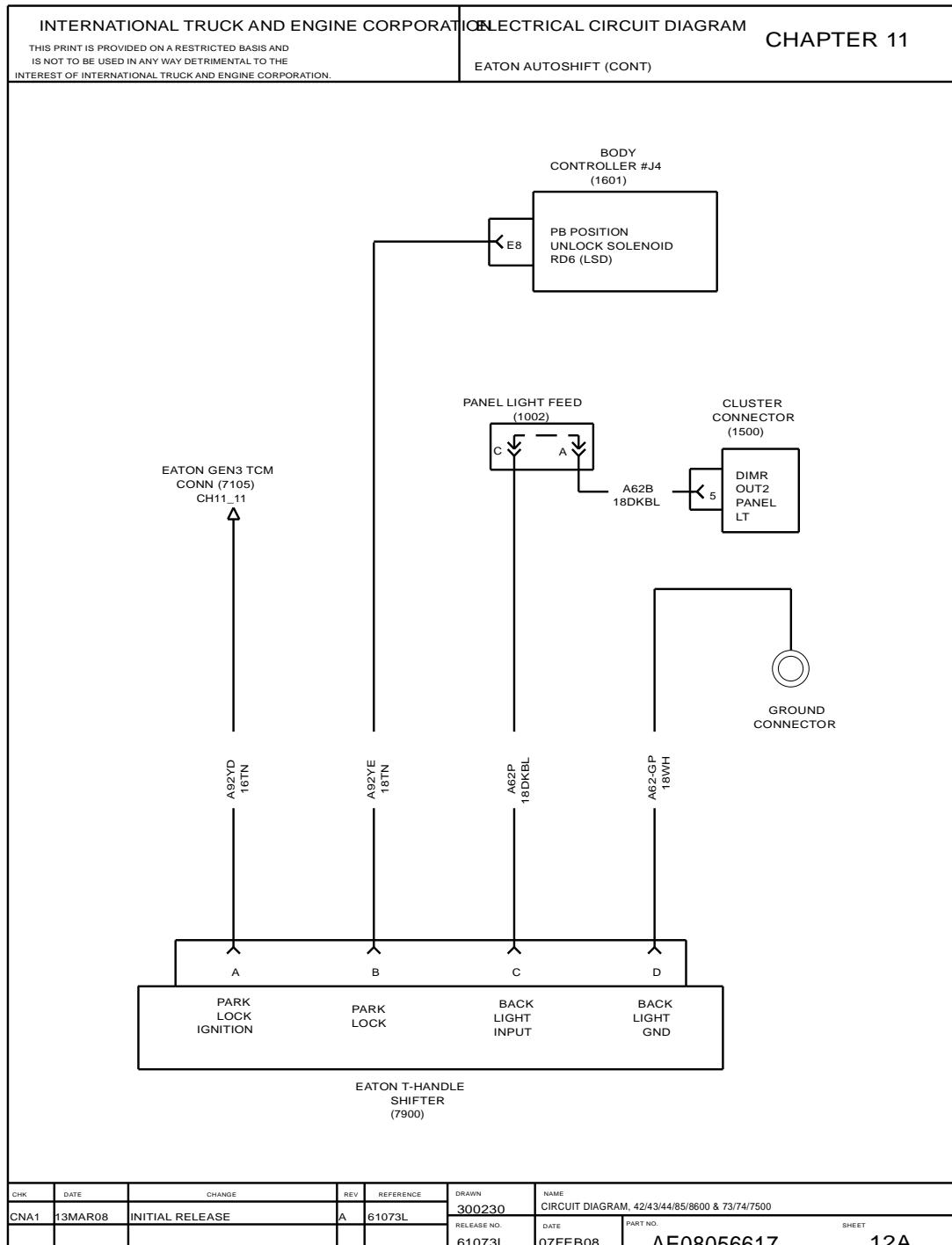

Figure 229 Eaton Autoshift Transmission (Cont.)

CHK	DATE	CHANGE	REV	REFERENCE	DRAWN	NAME
CNA1	13MAR08	INITIAL RELEASE	A	61073L	300230	CIRCUIT DIAGRAM, 42/43/44/85/8600 & 73/74/7500
					RELEASE NO.	DATE
					61073L	07FEB08
					PART NO.	SHEET
					AE08056617	12A

11.25. EATON HYBRID TRANSMISSION (CONT.), P. 22

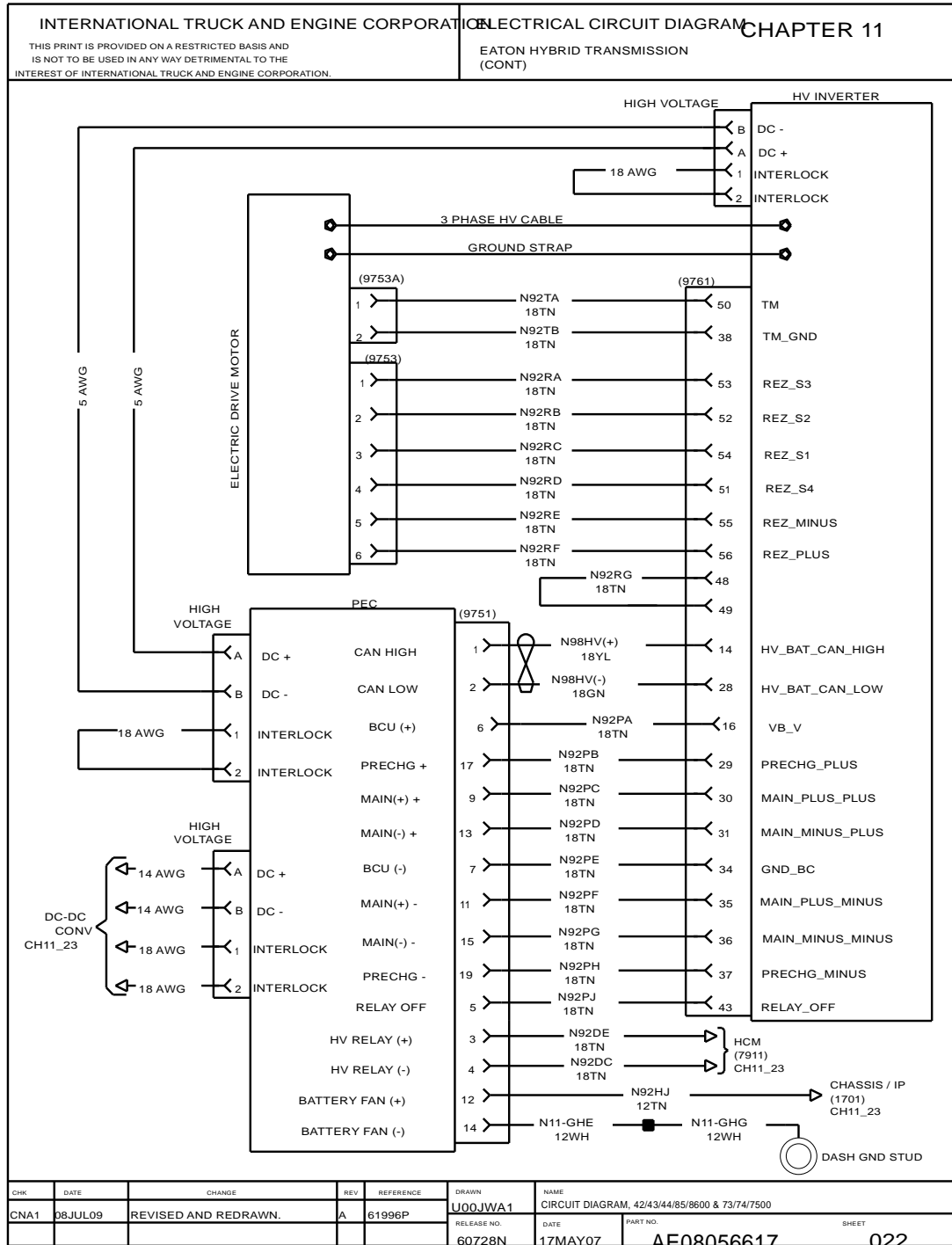

Figure 239 Eaton Hybrid Transmission (Cont.)

AIR CONDITIONING (CHAPTER 12)

12.1. AIR CONDITIONING, P. 1

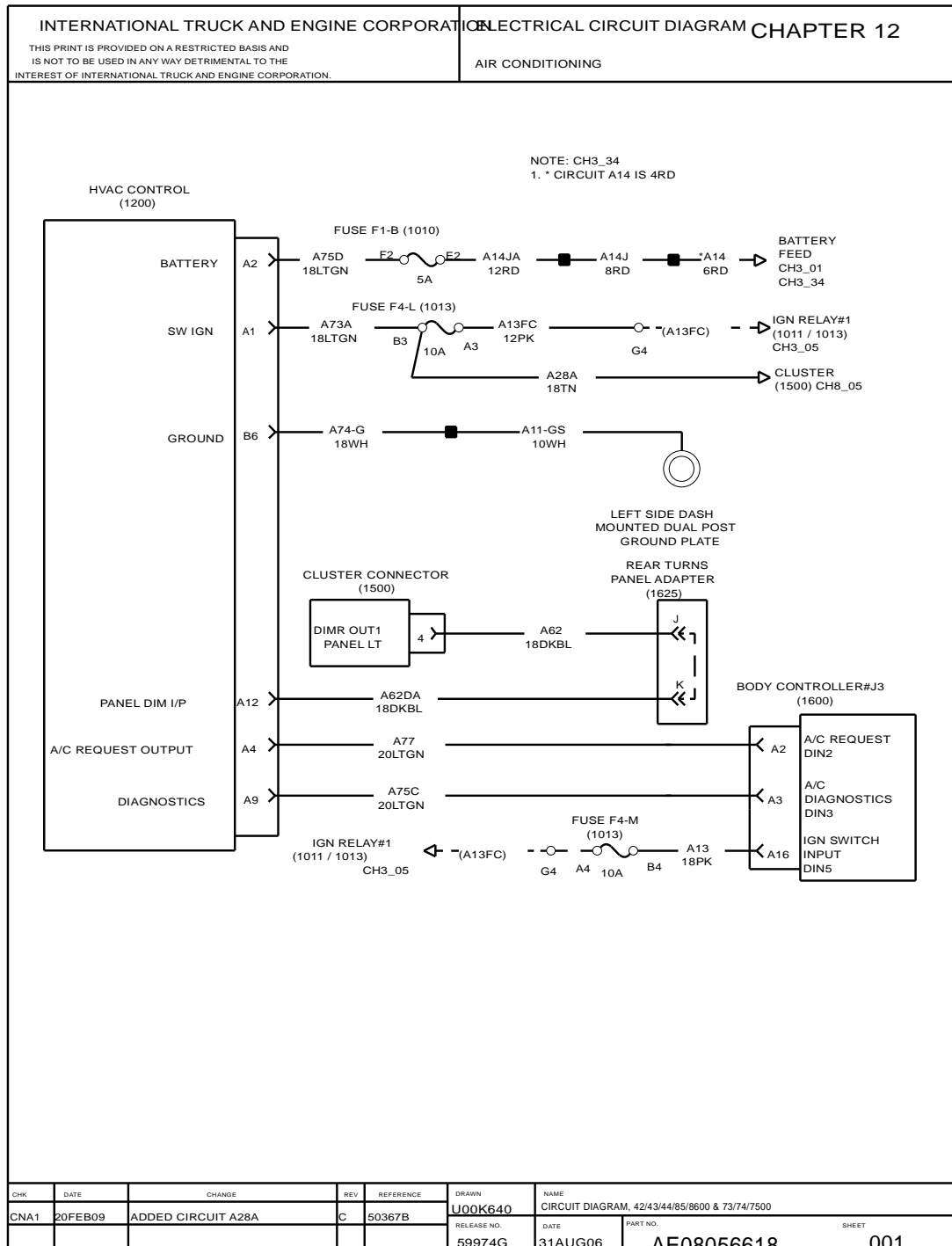

Figure 249 Air Conditioning

13.5. CONNECTOR COMPOSITES (672M), (674), (674M), (675), (675M), (677), P. 4A

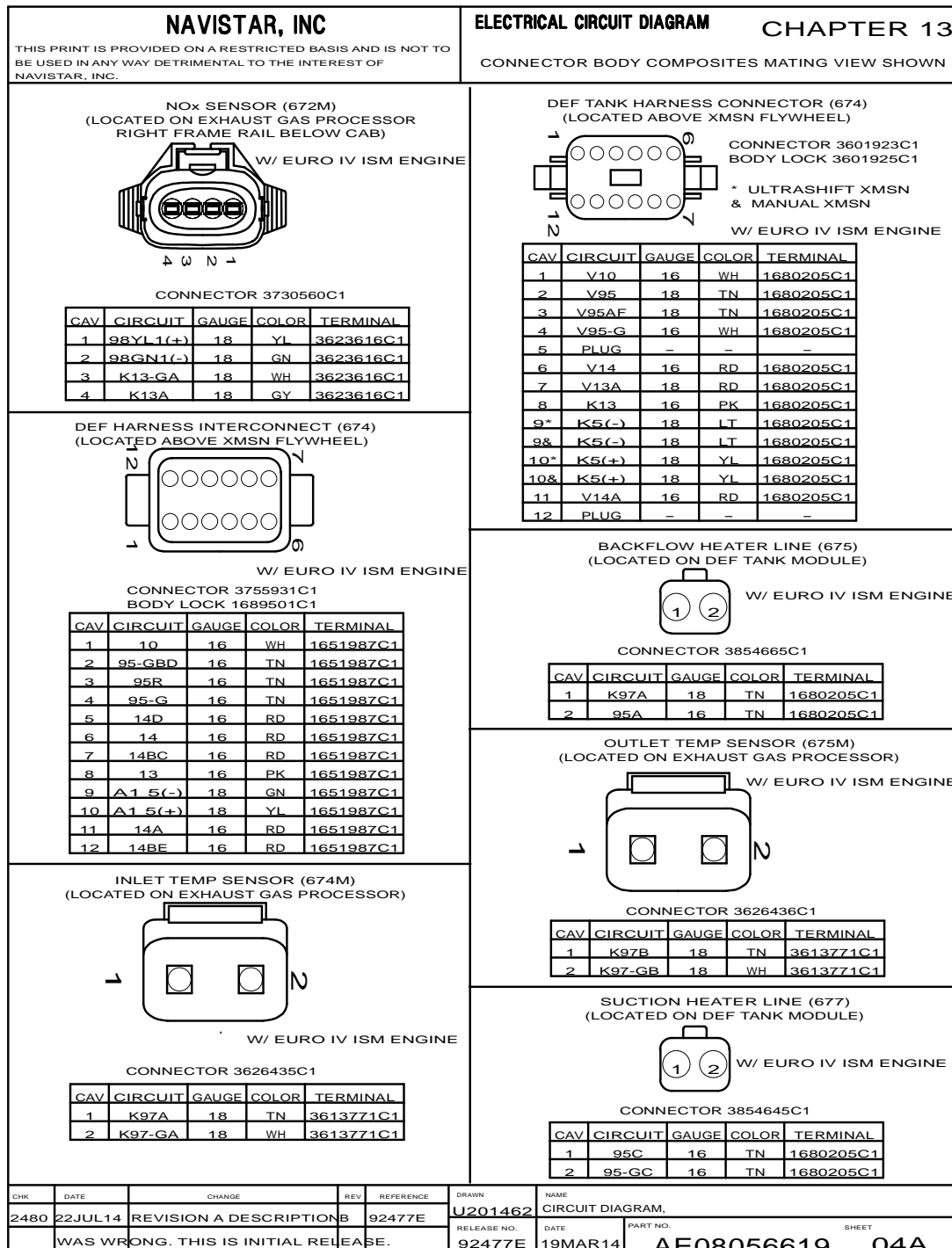

Figure 259 Connector Composites (672M), (674), (674M), (675), (675M), (677)

13.15. CONNECTOR COMPOSITE (1015), P. 12

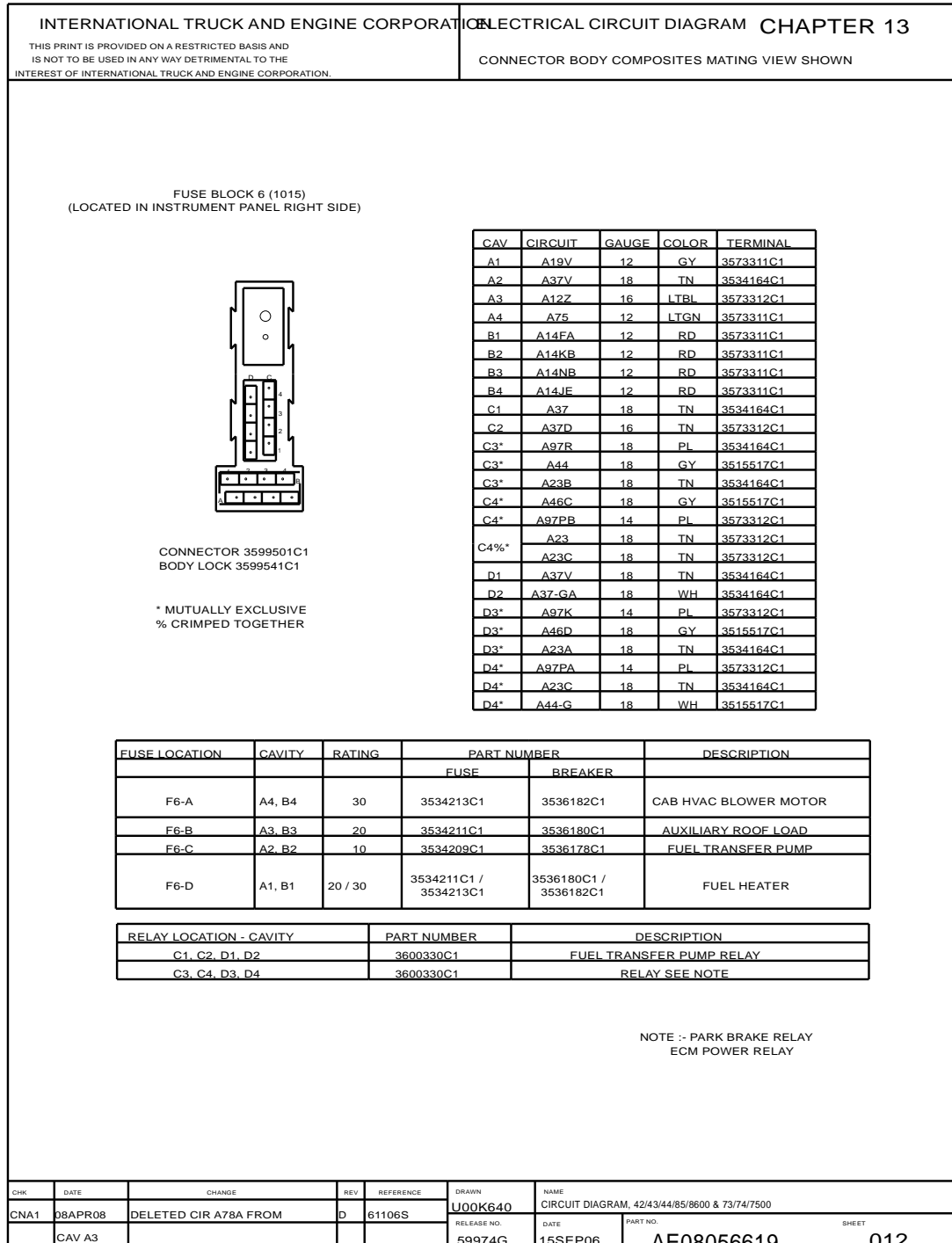

Figure 269 Connector Composite (1015)

13.25. CONNECTOR COMPOSITES (1100), (1100MA), (1101), (1101A), P. 20

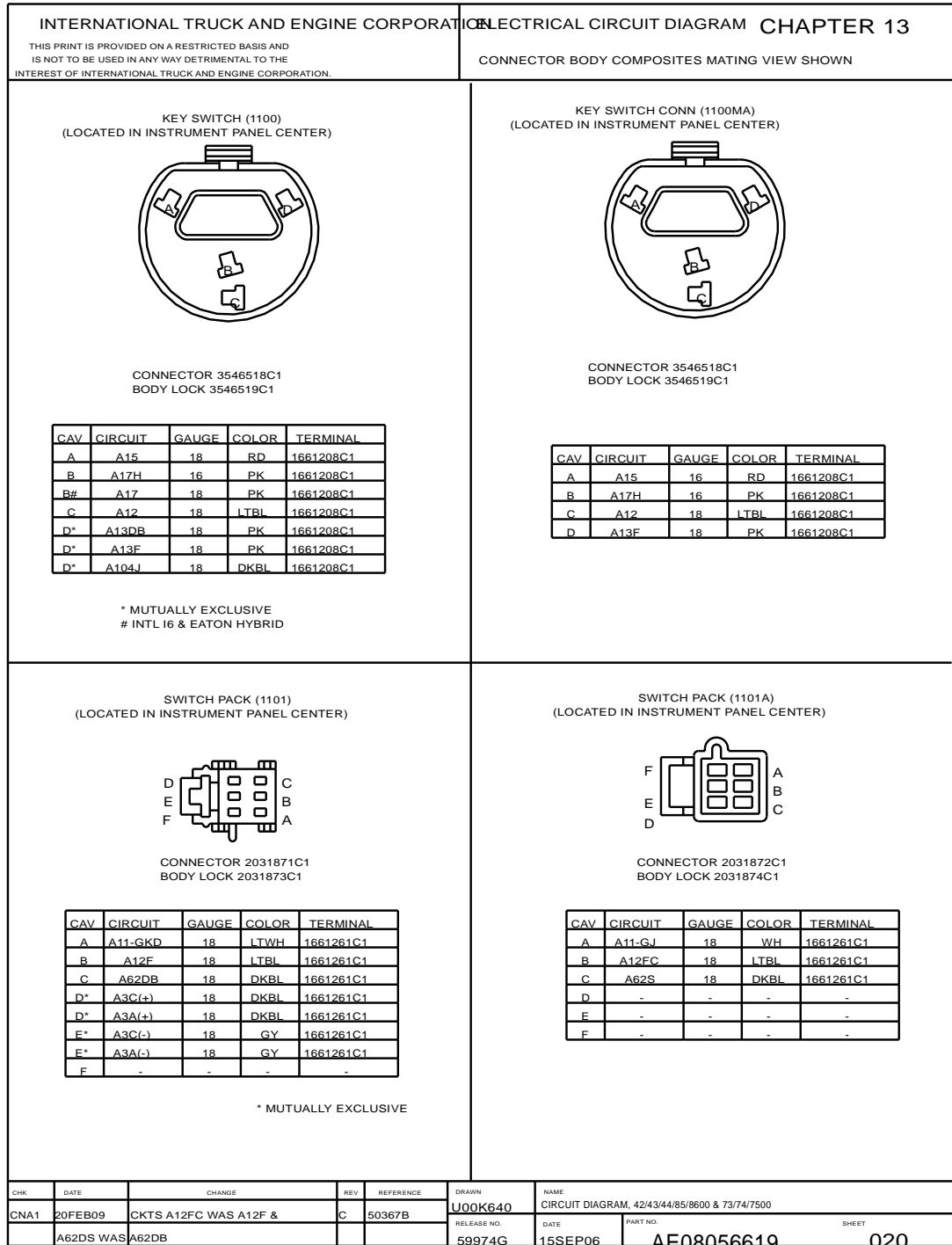

Figure 279 Connector Composites (1100), (1100MA), (1101), (1101A)

13.35. CONNECTOR COMPOSITES (1556), (1557), (1558), (1600), P. 29

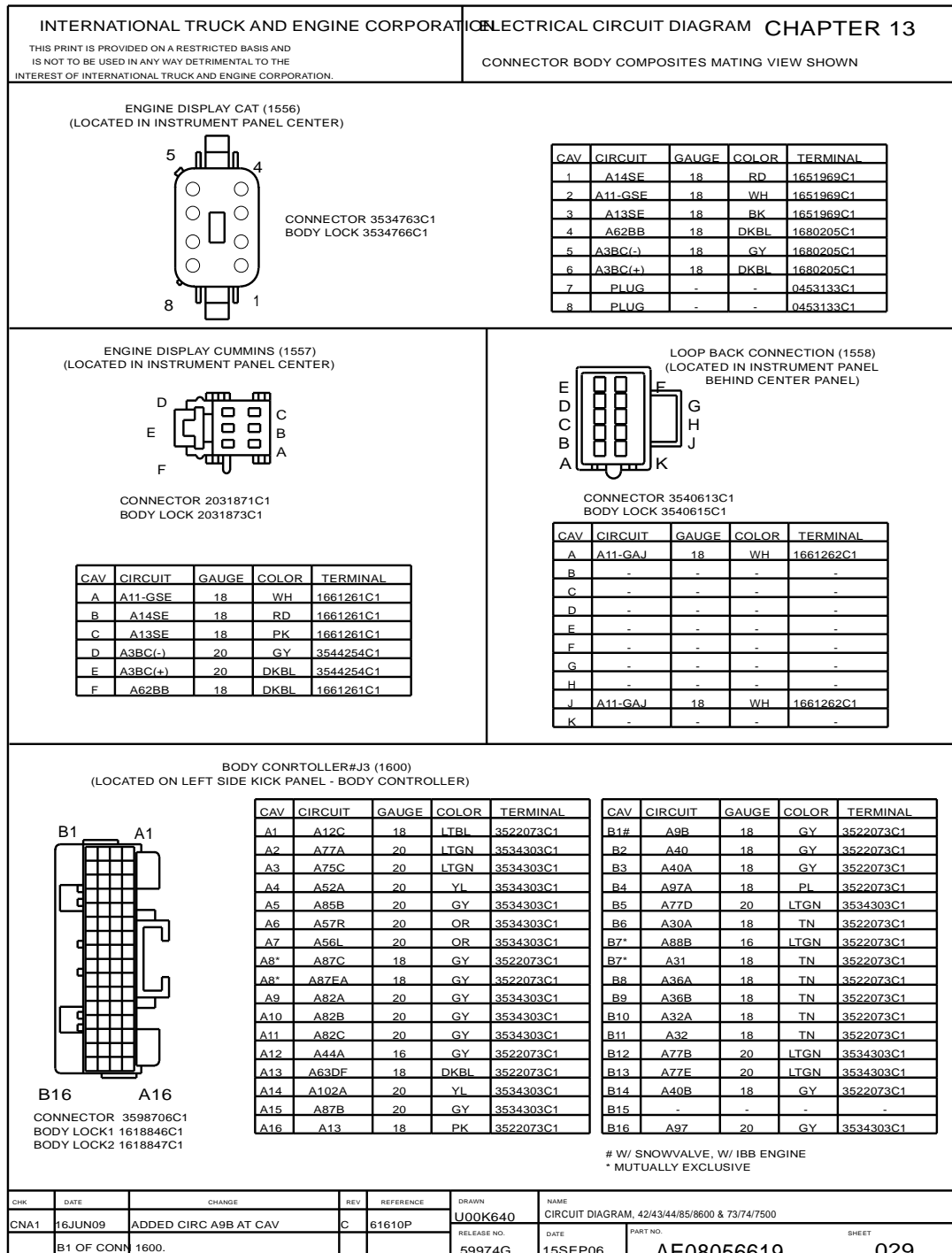

Figure 289 Connector Composites (1556), (1557), (1558), (1600)

13.45. CONNECTOR COMPOSITE (1701), P. 39

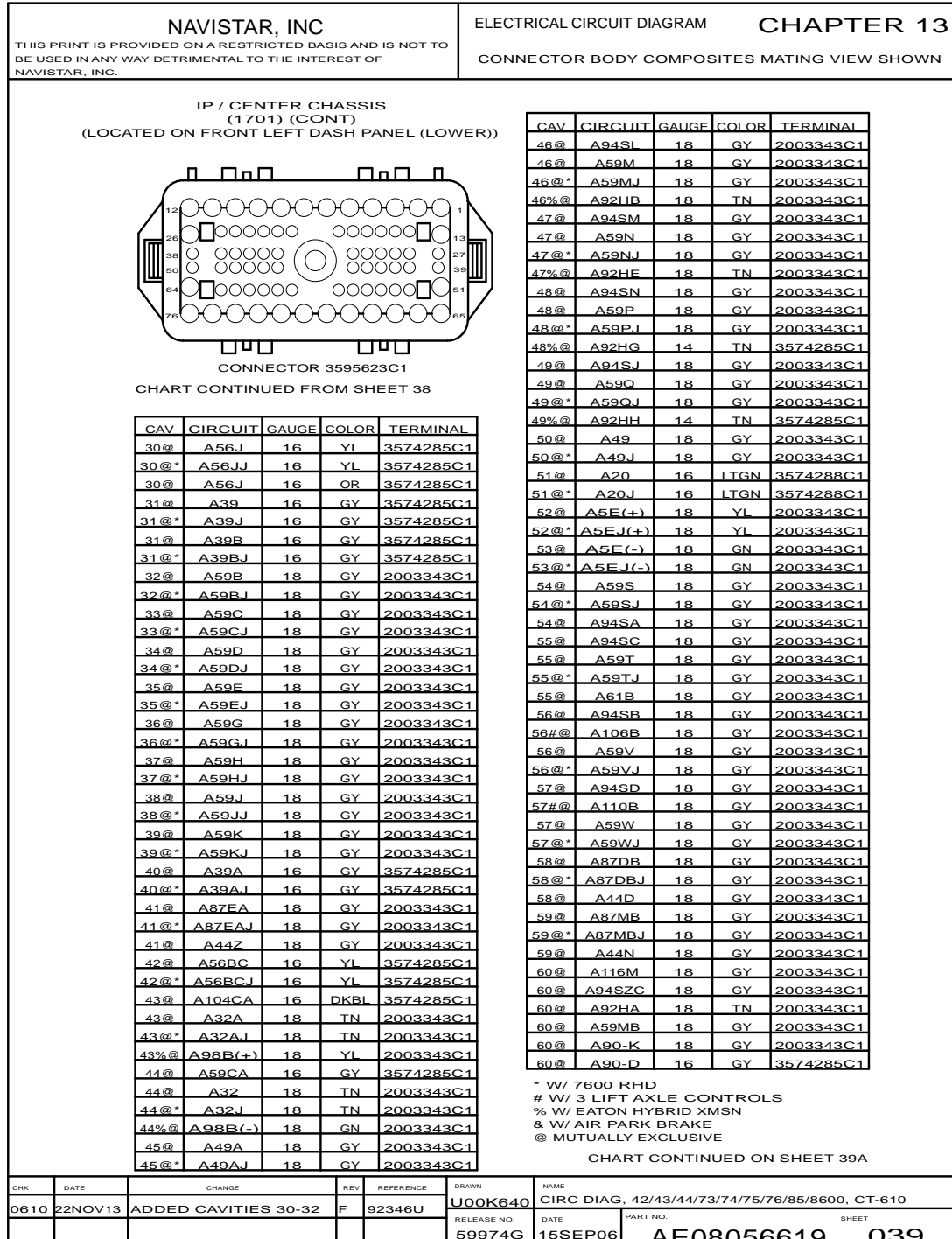

Figure 299 Connector Composite (1701)

13.55. CONNECTOR COMPOSITES (1820), (1821), P. 47A

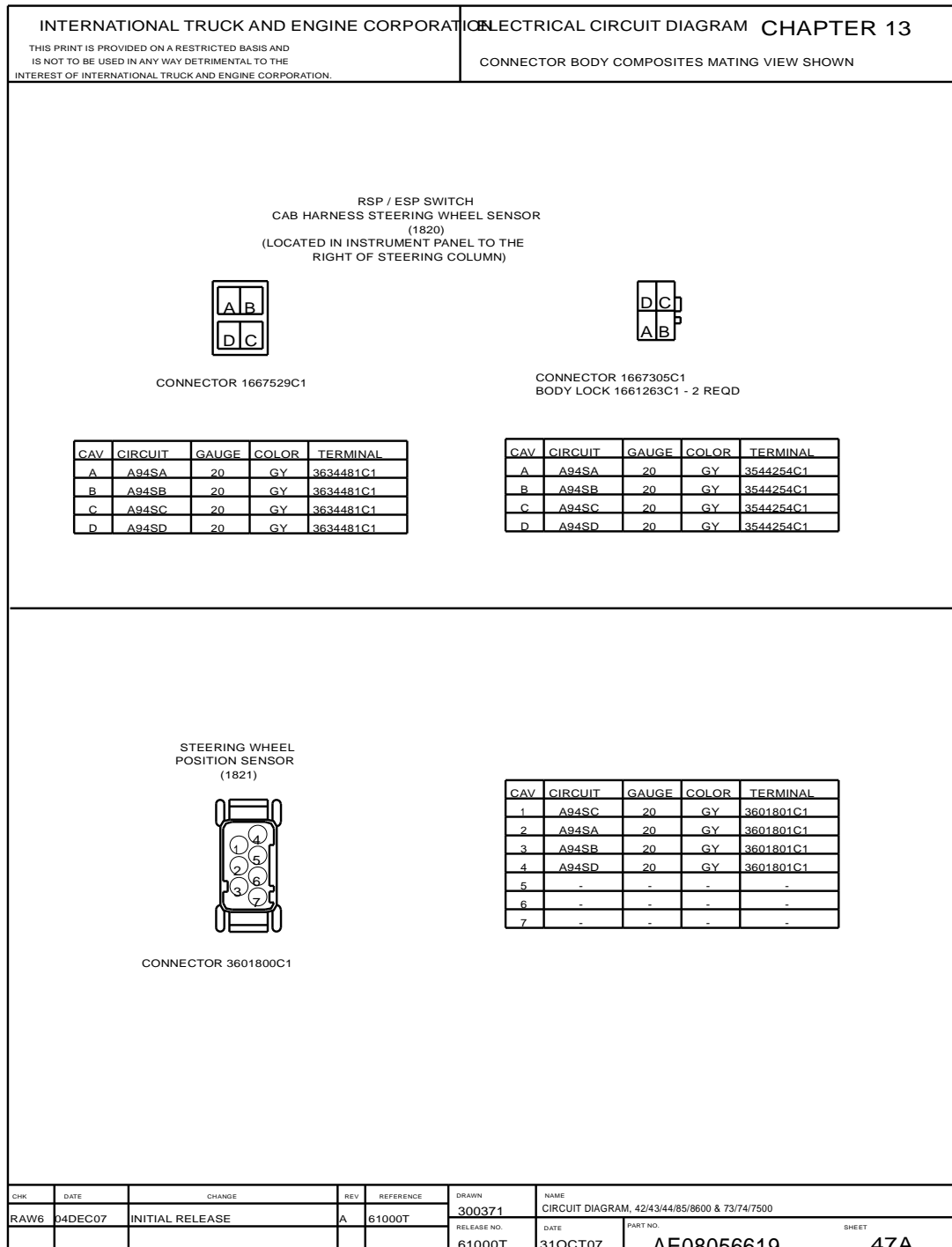

Figure 309 Connector Composites (1820), (1821)

13.65. CONNECTOR COMPOSITES (2700), (2700M), P. 56

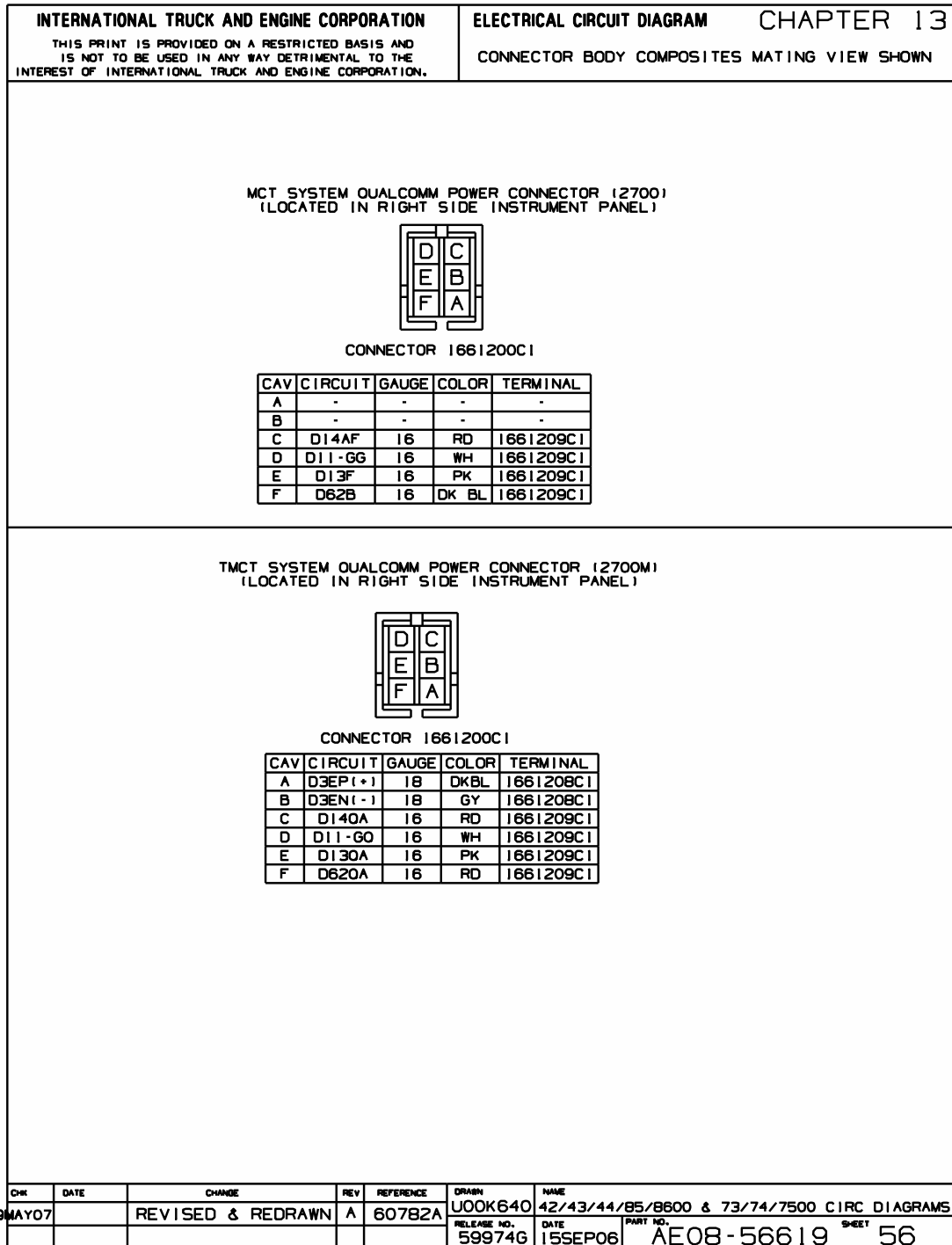

Figure 319 Connector Composites (2700), (2700M)

13.75. CONNECTOR COMPOSITES (4410F), (4410H), (4410K), (4410L), (4410M), P. 65

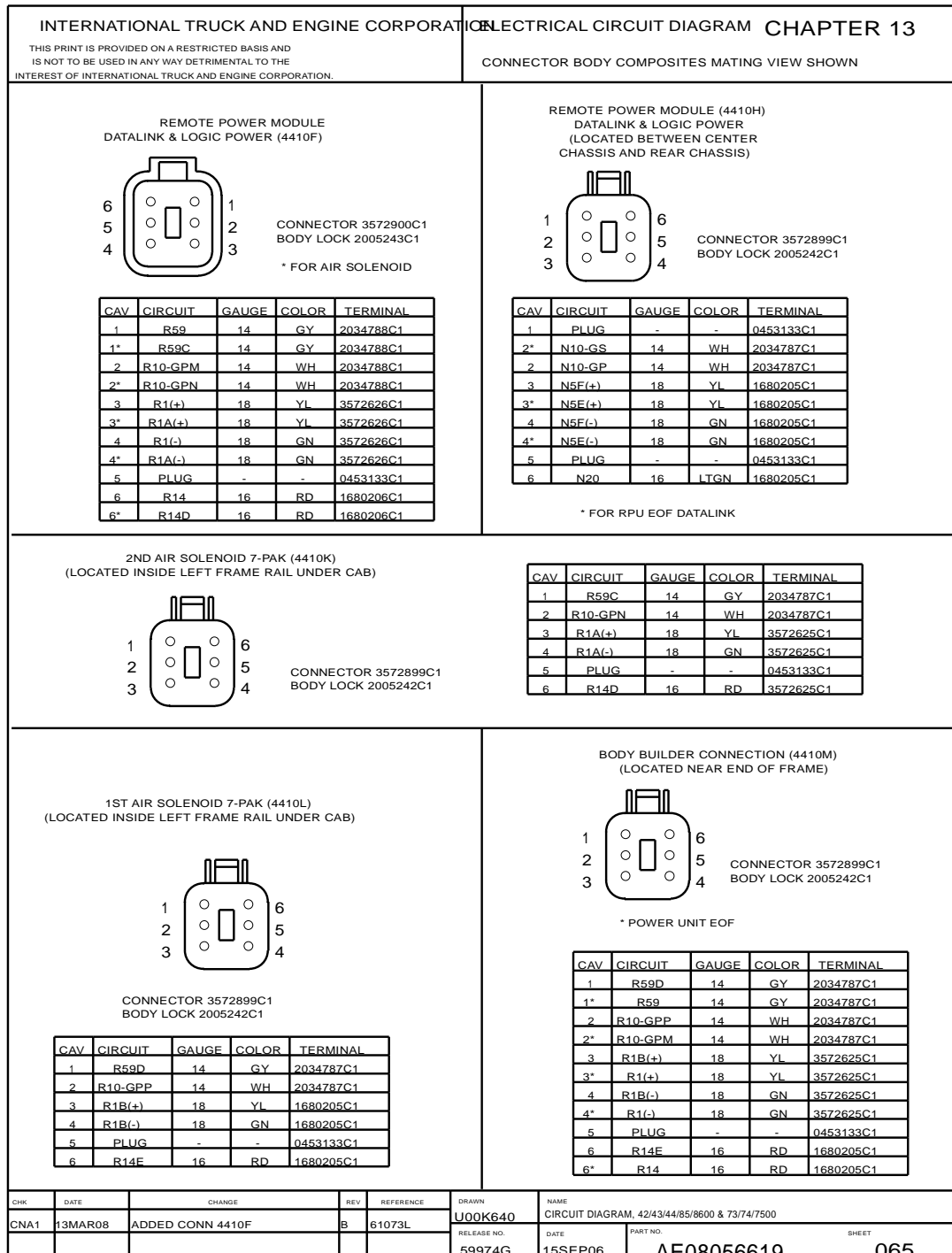

Figure 329 Connector Composites (4410F), (4410H), (4410K), (4410L), (4410M)

13.85. CONNECTOR COMPOSITES (6200), (6201), (6259), P. 74

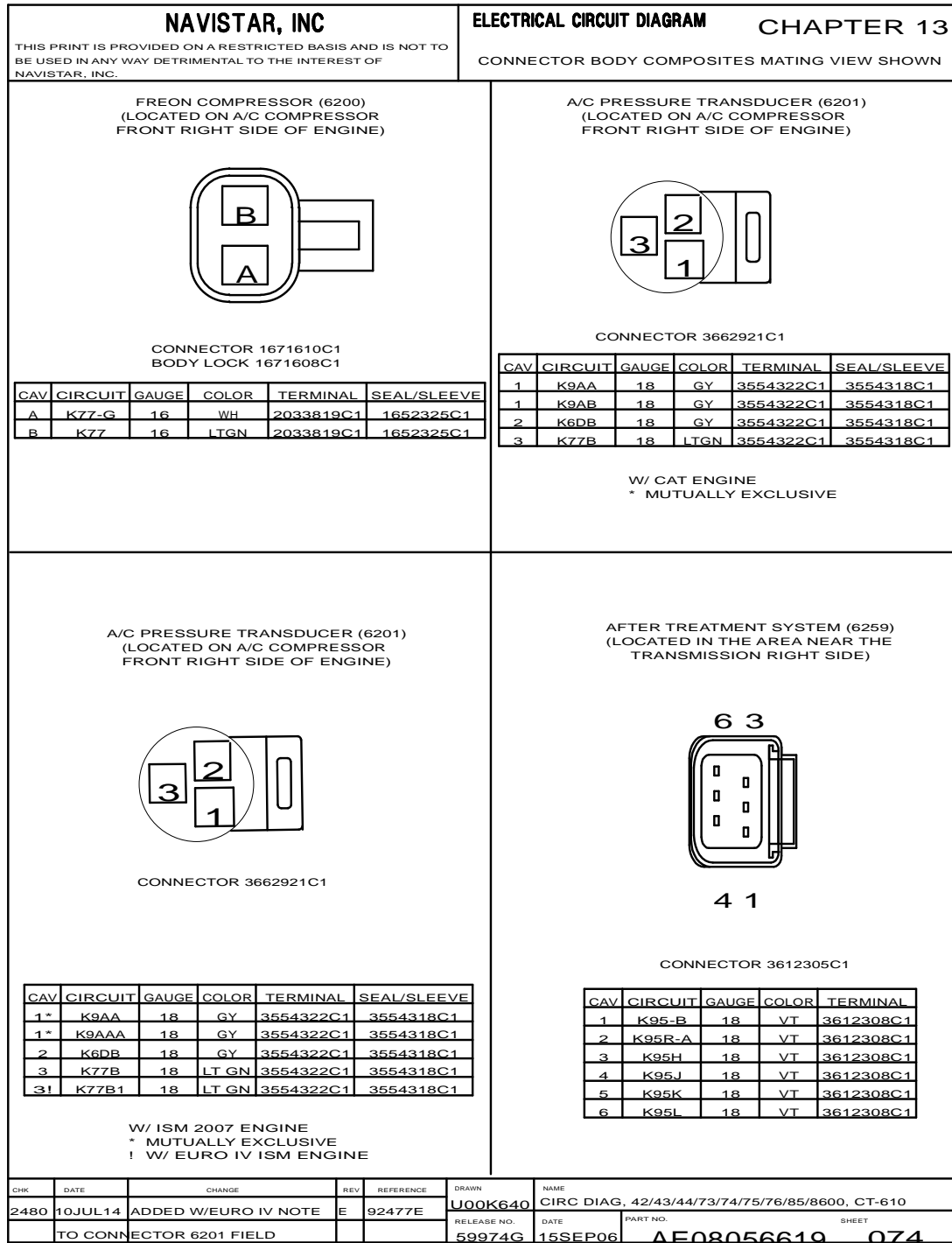

Figure 339 Connector Composites (6200), (6201), (6259)

13.95. CONNECTOR COMPOSITES (6900), (6901), (7103), (7103M), (7104), P. 80

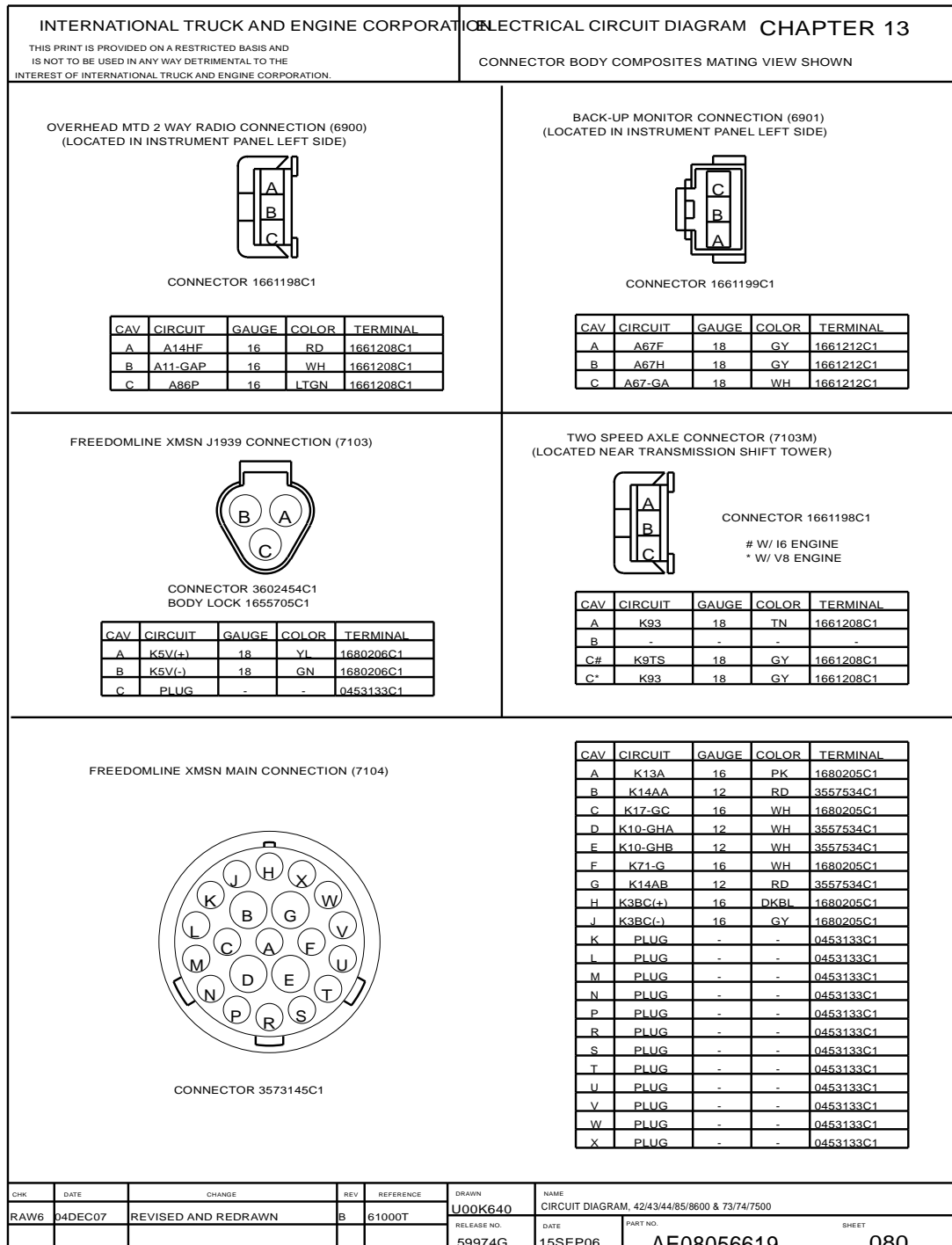

Figure 349 Connector Composites (6900), (6901), (7103), (7103M), (7104)

13.105. CONNECTOR COMPOSITES (7602), (7603), (7604), (7605), (7607), (7608), (7609), (7611), P. 90

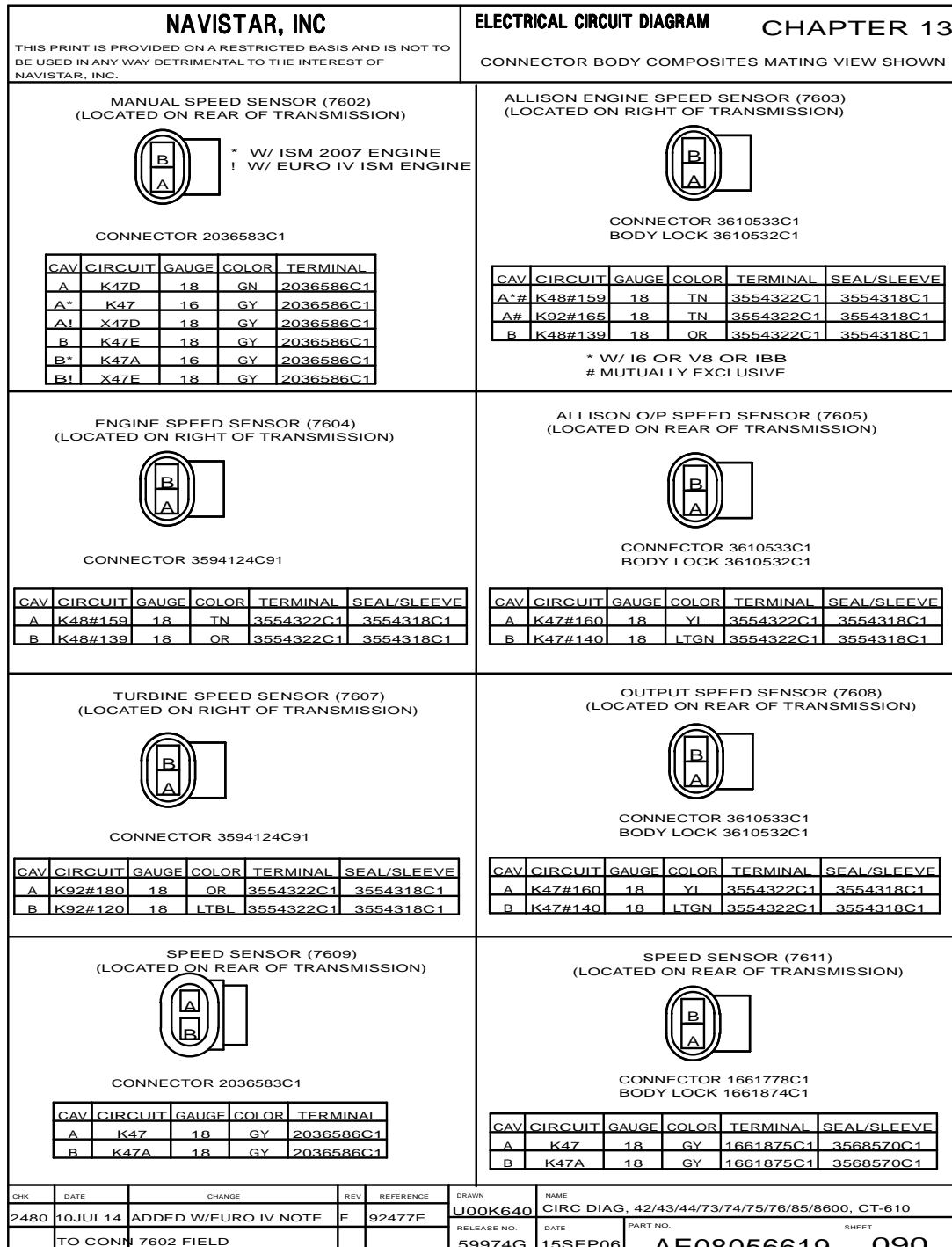

Figure 359 Connector Composites (7602), (7603), (7604), (7605), (7607), (7608), (7609), (7611)

13.115. CONNECTOR COMPOSITES (8503), (8503A), (8505), (8506), (8506A), (8507), (8507A), (8508), P. 97

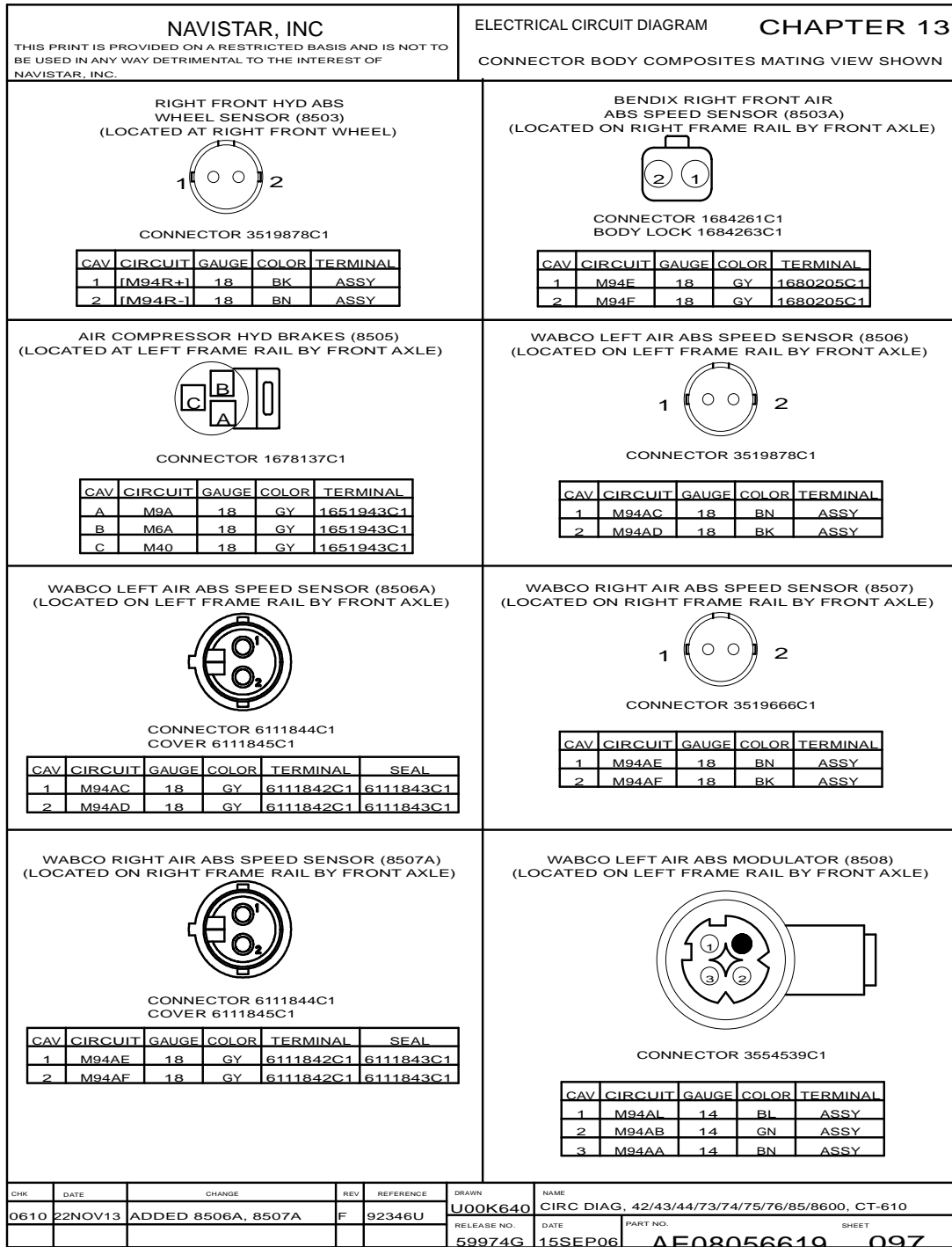

Figure 369 Connector Composites (8503), (8503A), (8505), (8506), (8506A), (8507), (8507A), (8508)

13.125. CONNECTOR COMPOSITE (9511), P. 105

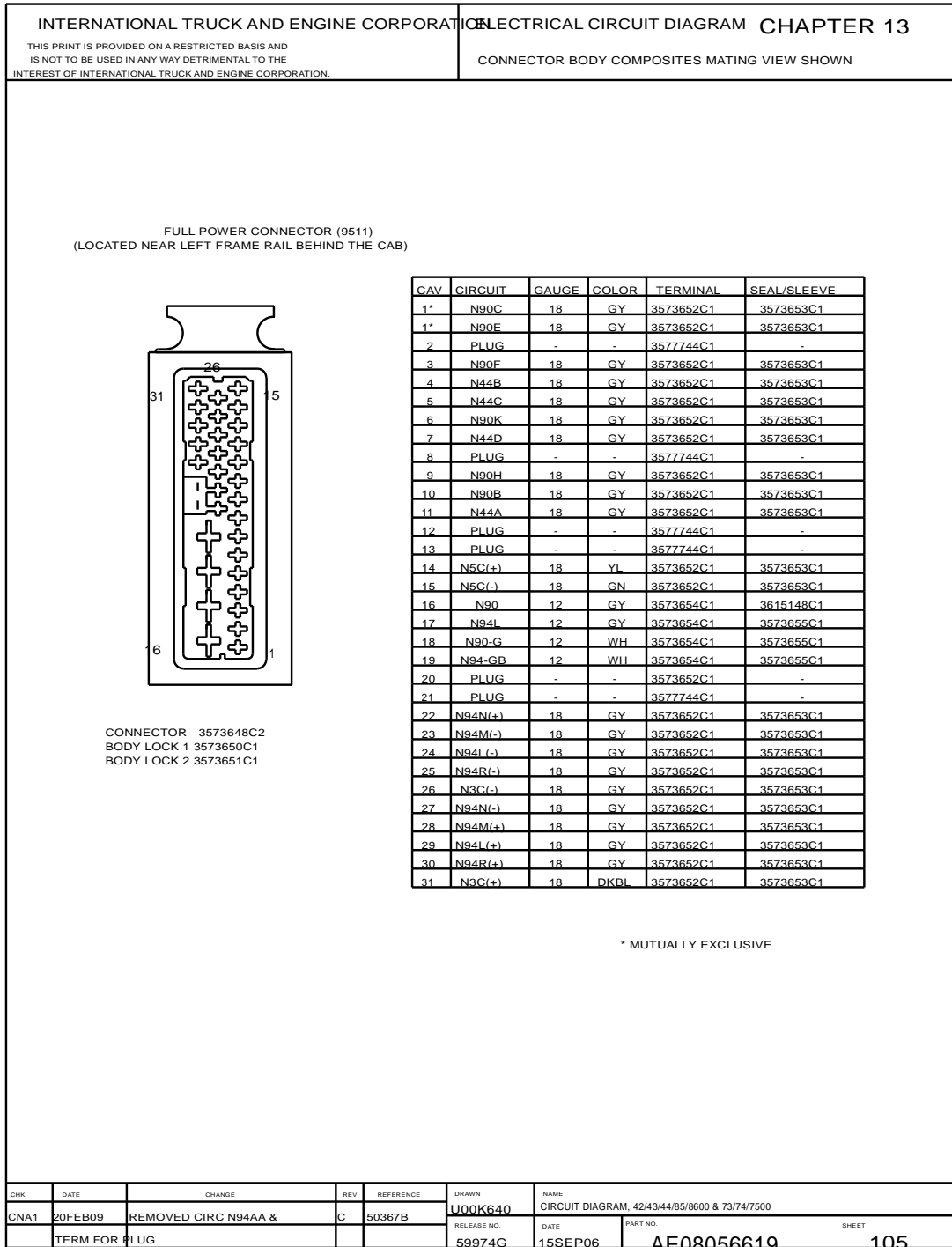

Figure 379 Connector Composite (9511)

CLICK HERE TO **DOWNLOAD** THE COMPLETE MANUAL

- Thank you very much for reading the preview of the manual.
- You can download the complete manual from: www.heydownloads.com by clicking the link below



- Please note: If there is no response to CLICKING the link, please download this PDF first and then click on it.

CLICK HERE TO **DOWNLOAD** THE COMPLETE MANUAL