



# **Range Rover Sport Electrical Circuit Diagrams**

VIN: 900302 onwards

**Publication Part No. LRE091\_3 ENGX**

**Published by Land Rover**

**© 2006 Land Rover**

All rights reserved. No part of this publication may be reproduced, stored in a retrieval system or transmitted in any form, electronic, mechanical, recording or other means without prior written permission from Land Rover.

CLICK HERE TO **DOWNLOAD** THE COMPLETE MANUAL

- Thank you very much for reading the preview of the manual.
- You can download the complete manual from: [www.heydownloads.com](http://www.heydownloads.com) by clicking the link below



- Please note: If there is no response to CLICKING the link, please download this PDF first and then click on it.

CLICK HERE TO **DOWNLOAD** THE COMPLETE MANUAL

Switch pack-Centre-console (S350)

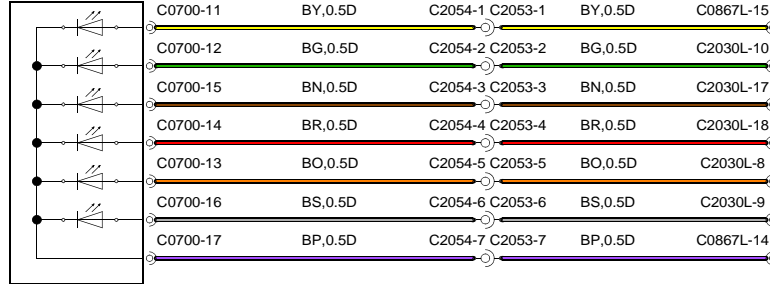

Front control valve (D281)

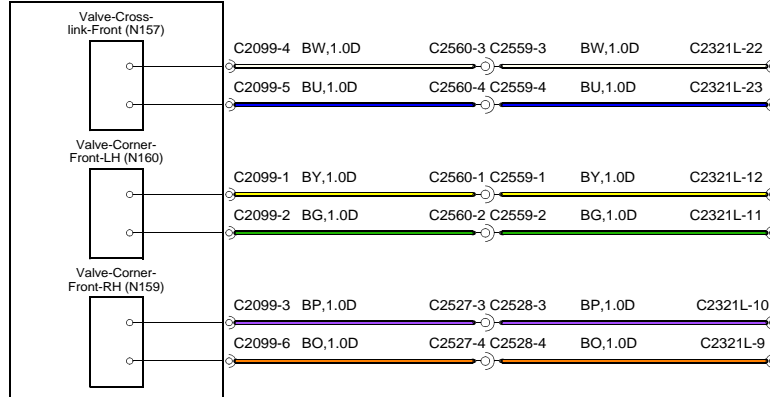

Sensor-Height-Front-LH (T236)

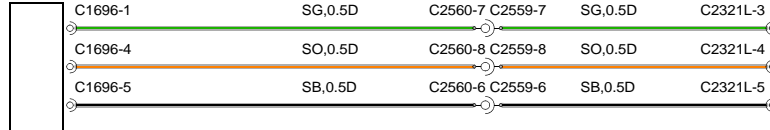

Sensor-Height-Rear-LH (T235)

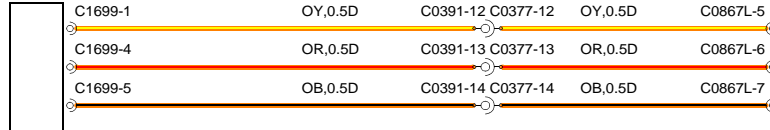

Air suspension Control Module (D199)

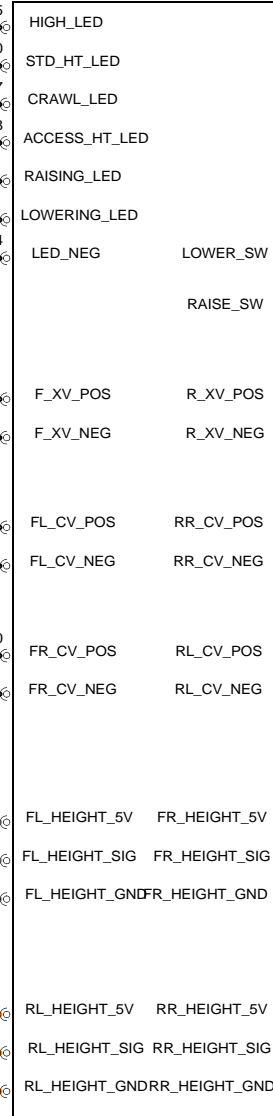

Switch pack-Centre-console (S350)

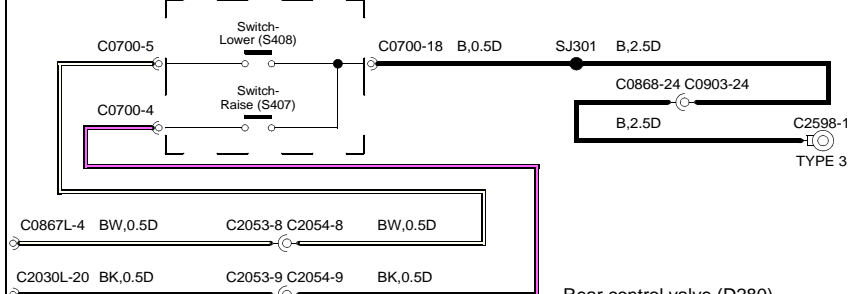

Rear control valve (D280)

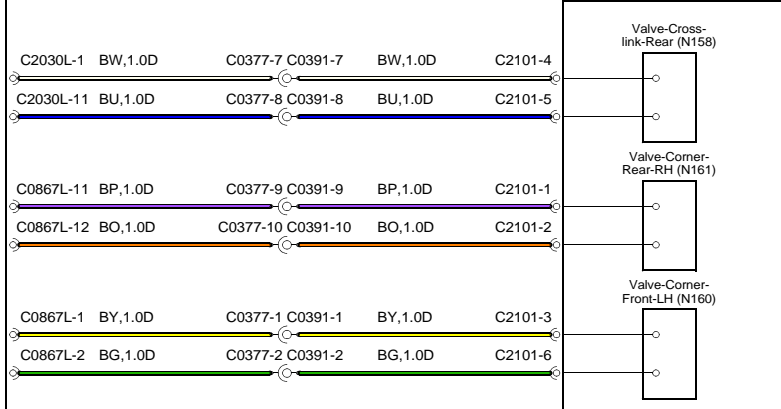

Sensor-Height-Front-RH (T238)

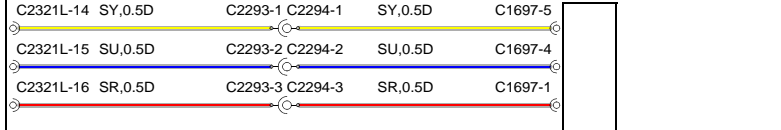

Sensor-Height-Rear-RH (T237)

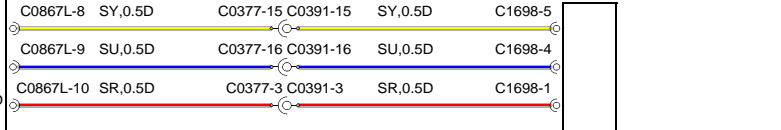

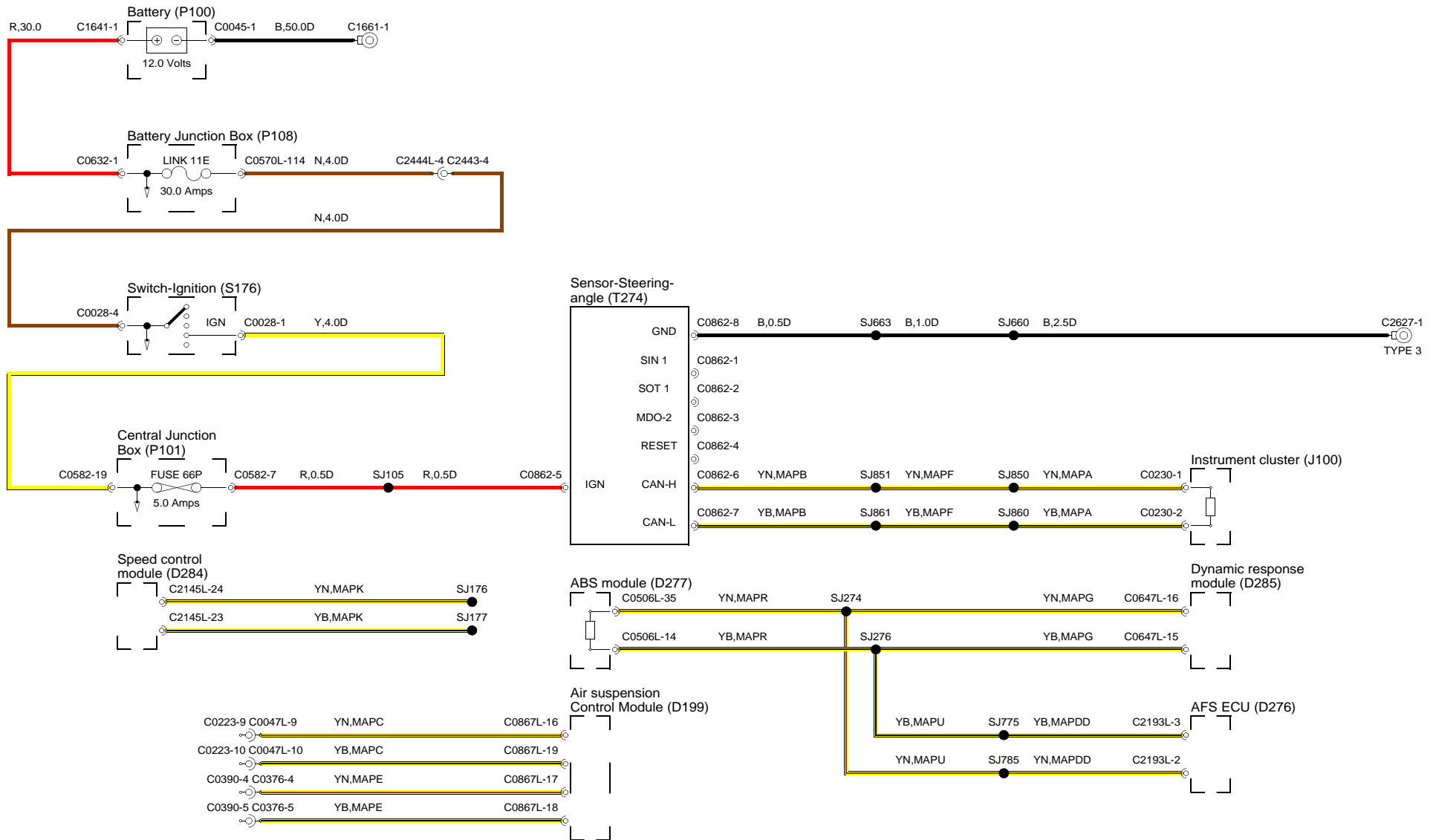

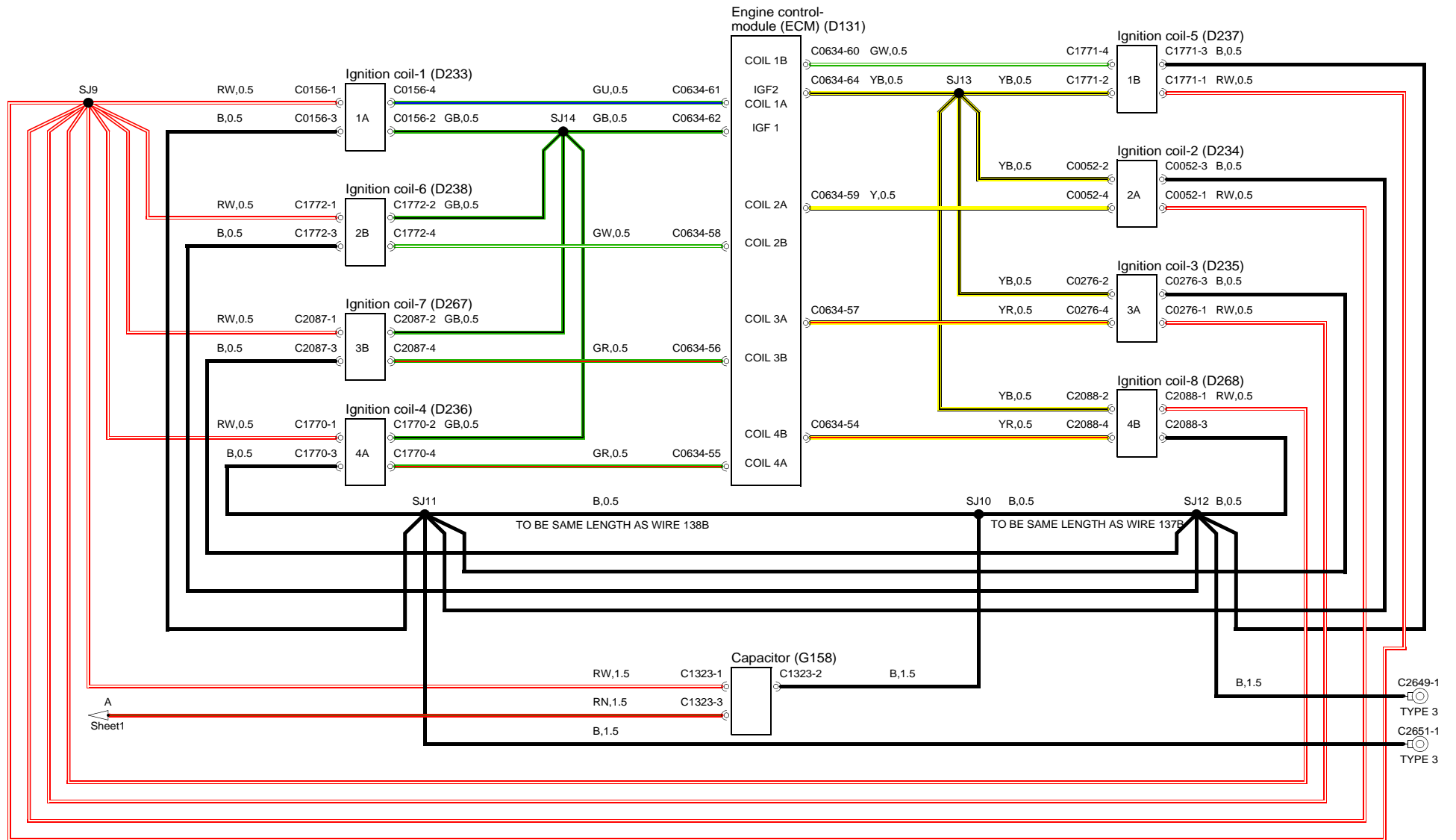

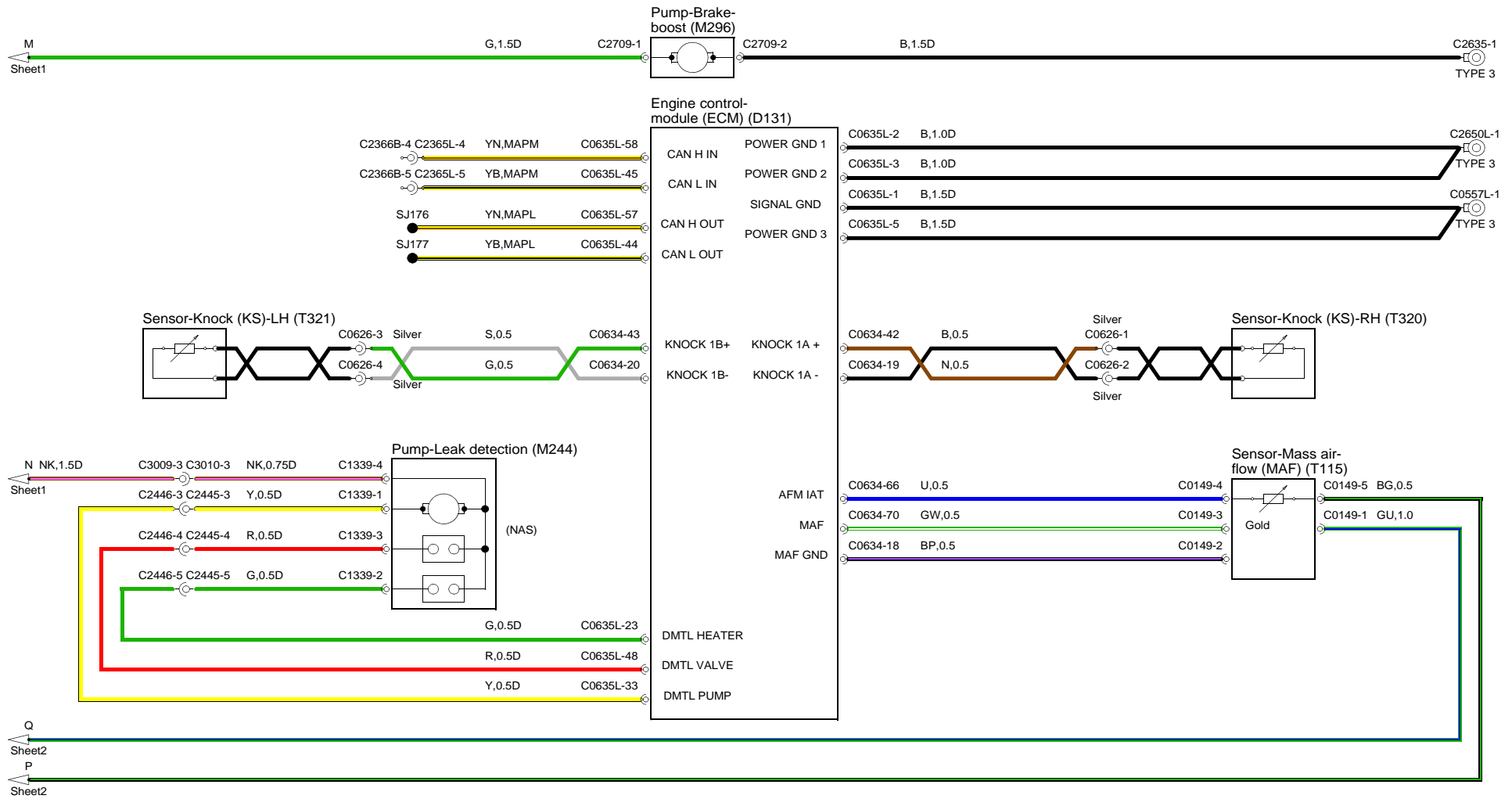

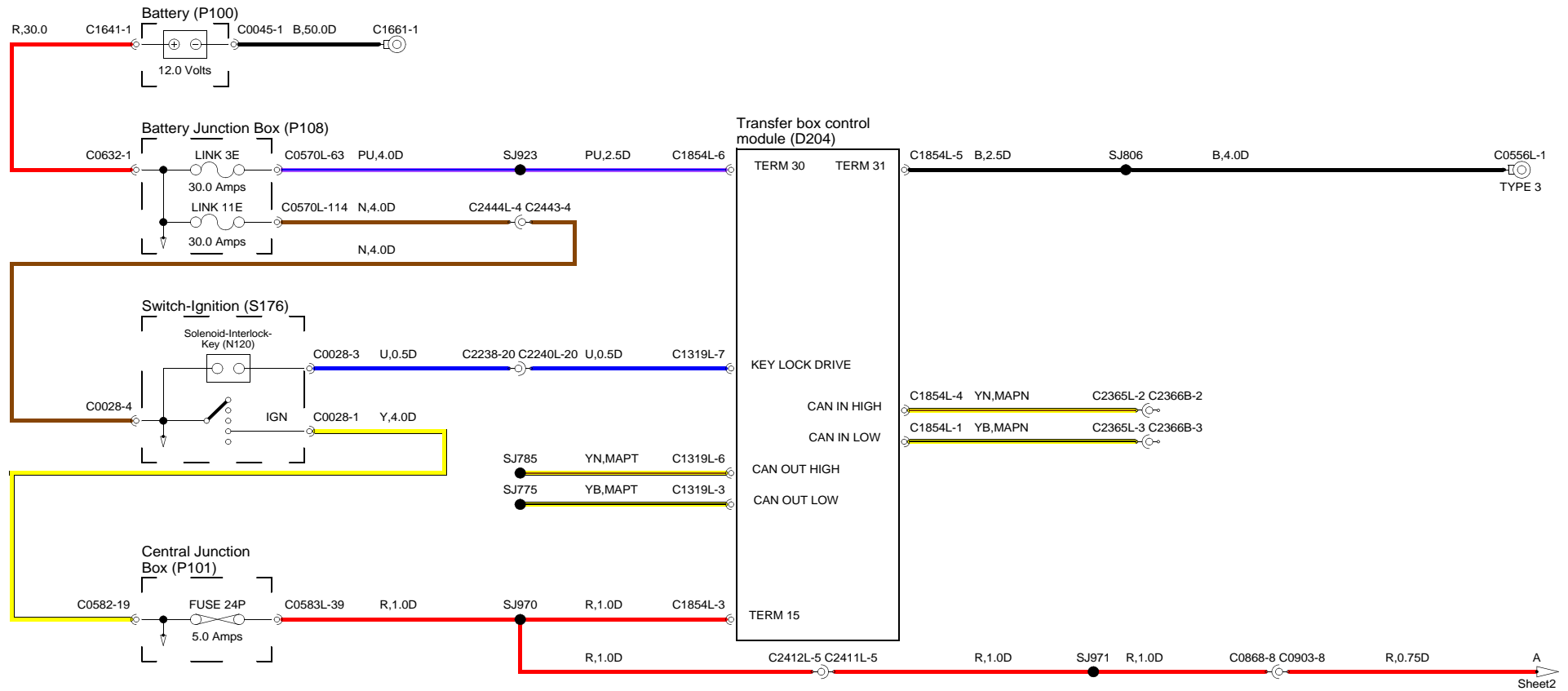

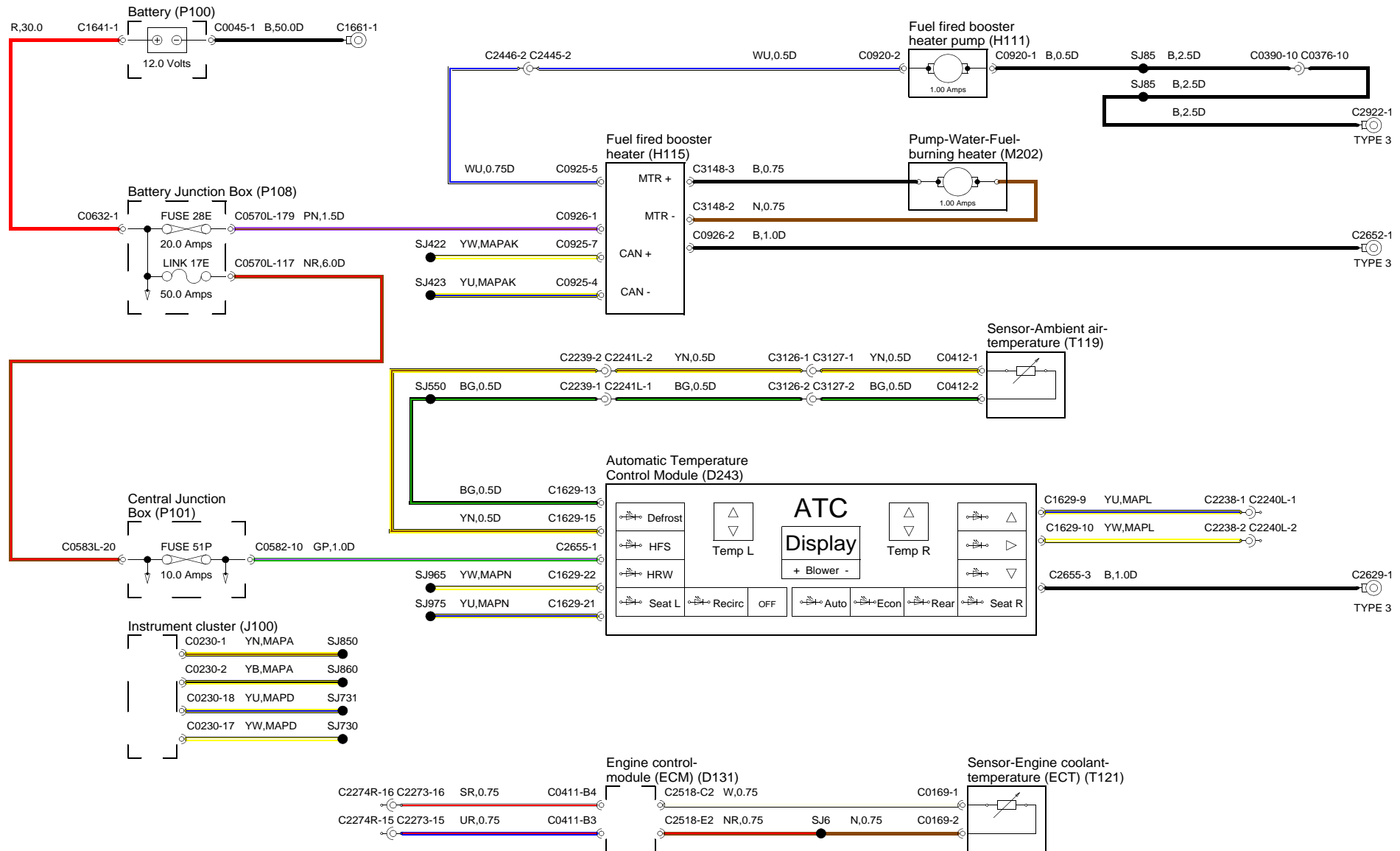

# 413-01 INSTRUMENT CLUSTER

## Instrument cluster (J100)

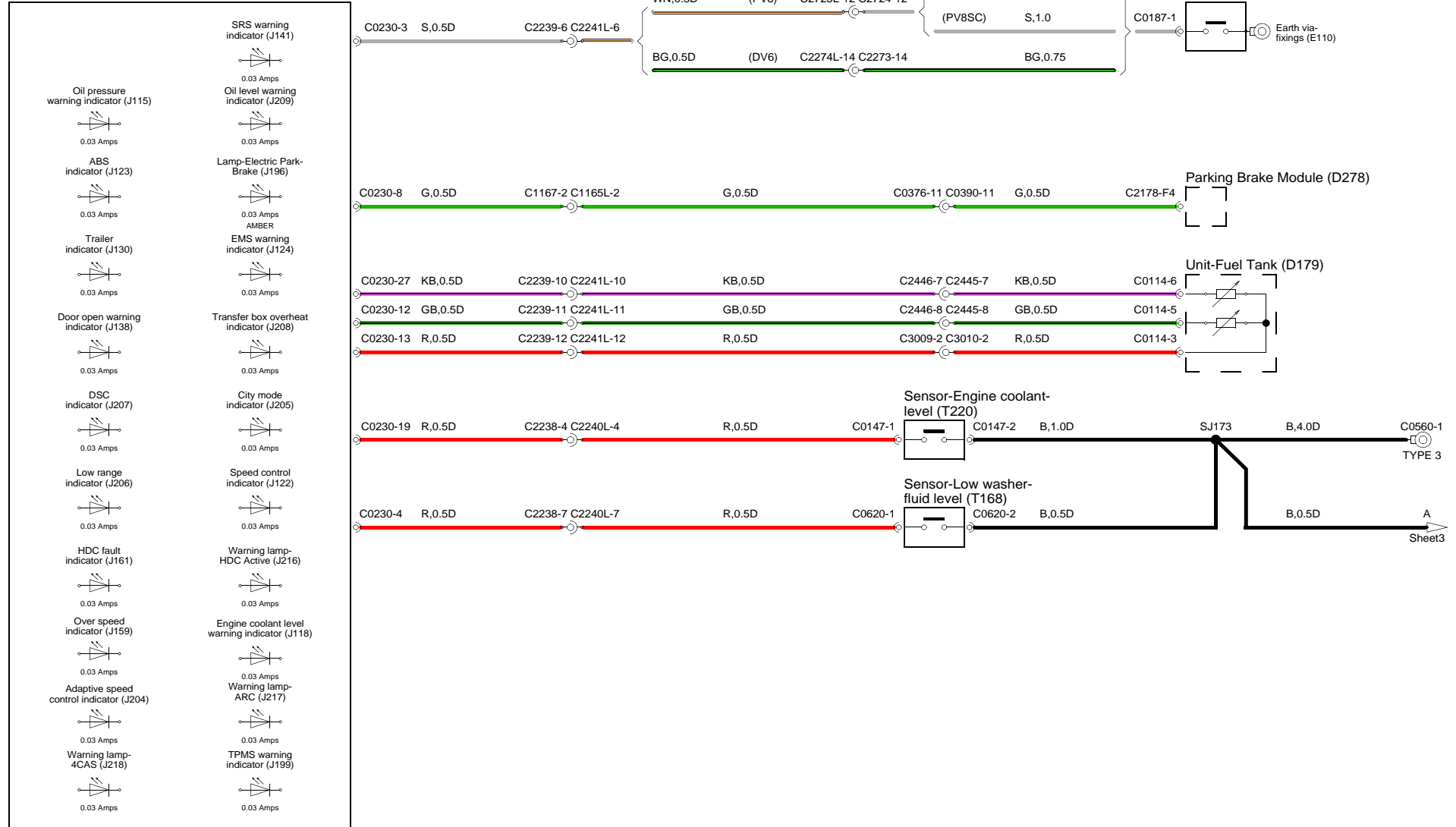

SJ31 (NP) MAIN

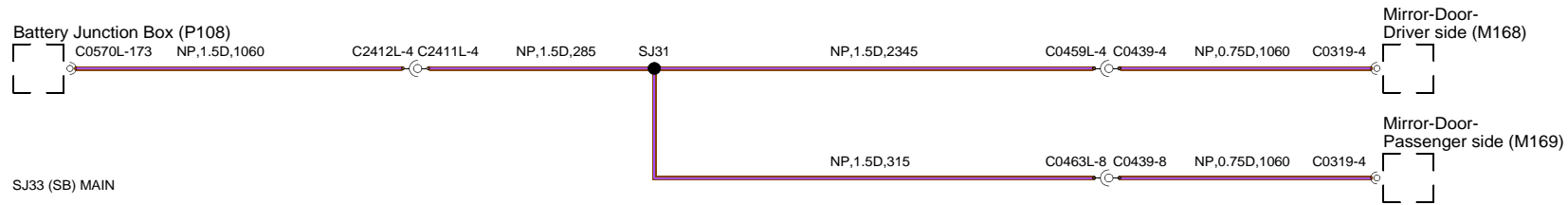

SJ33 (SB) MAIN

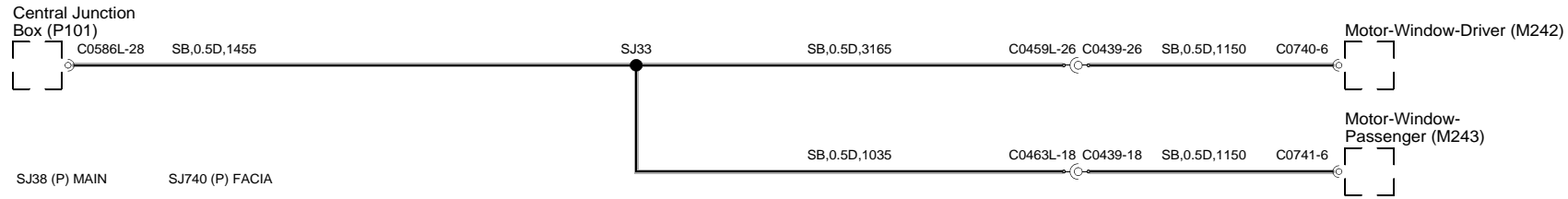

SJ38 (P) MAIN

SJ740 (P) FACIA

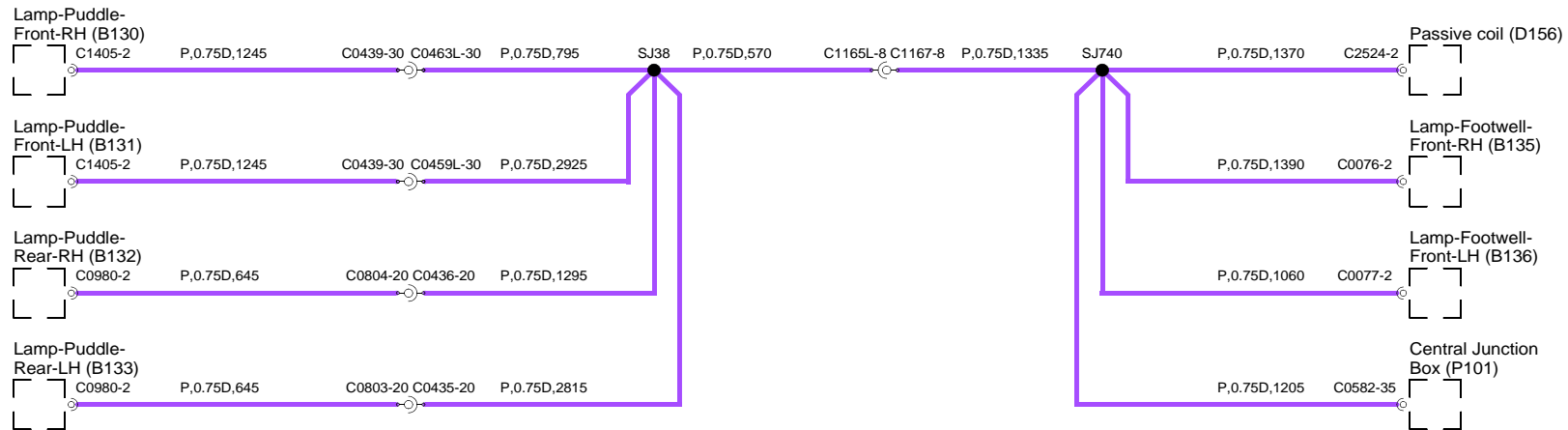

SJ39 (PW) MAIN

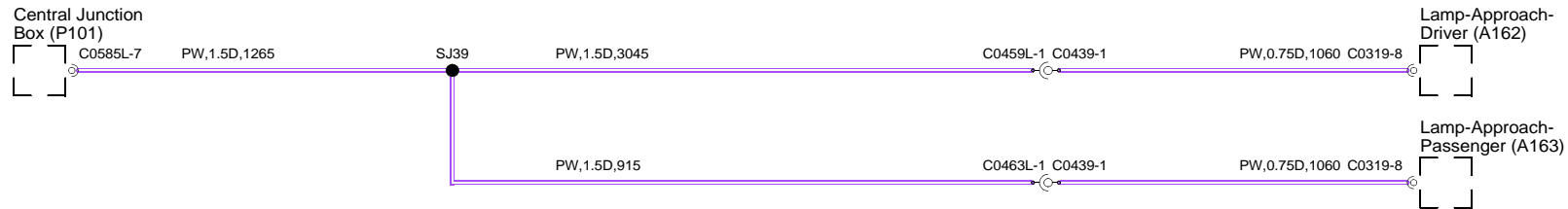

SJ406 (GY) REAR CHASSIS

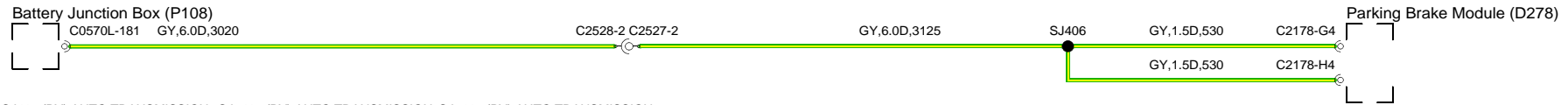

SJ410 (PY) AUTO TRANSMISSION SJ3410 (PY) AUTO TRANSMISSION SJ2410 (PY) AUTO TRANSMISSION

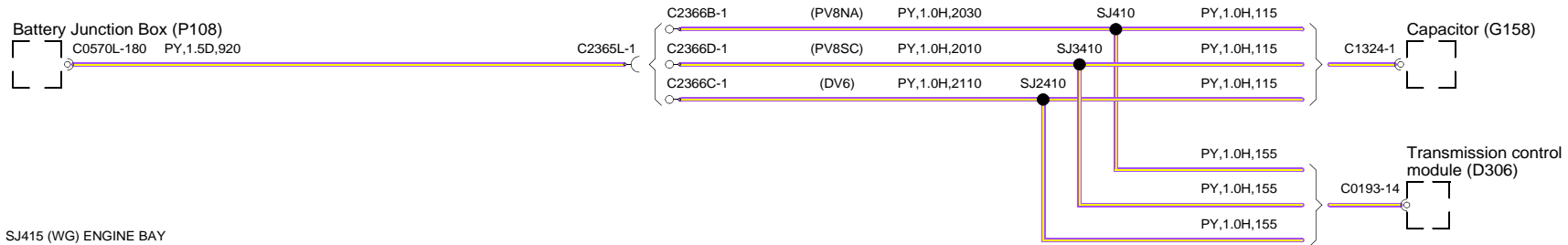

SJ415 (WG) ENGINE BAY

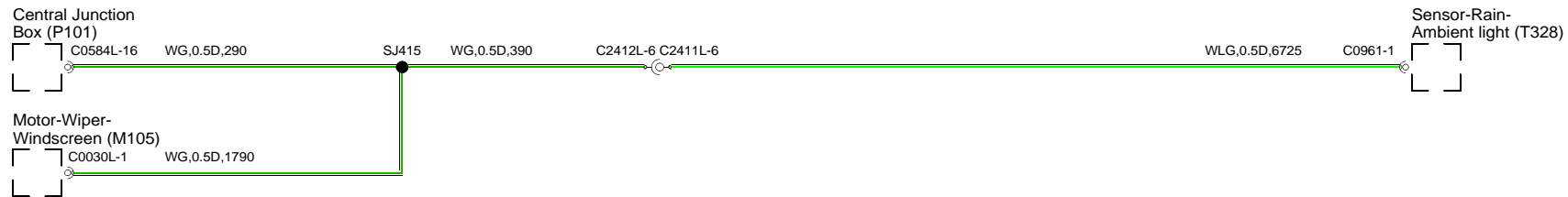

SJ442 (R) ENGINE-BAY



CLICK HERE TO **DOWNLOAD** THE COMPLETE MANUAL

- Thank you very much for reading the preview of the manual.
- You can download the complete manual from: [www.heydownloads.com](http://www.heydownloads.com) by clicking the link below



- Please note: If there is no response to CLICKING the link, please download this PDF first and then click on it.

CLICK HERE TO **DOWNLOAD** THE COMPLETE MANUAL

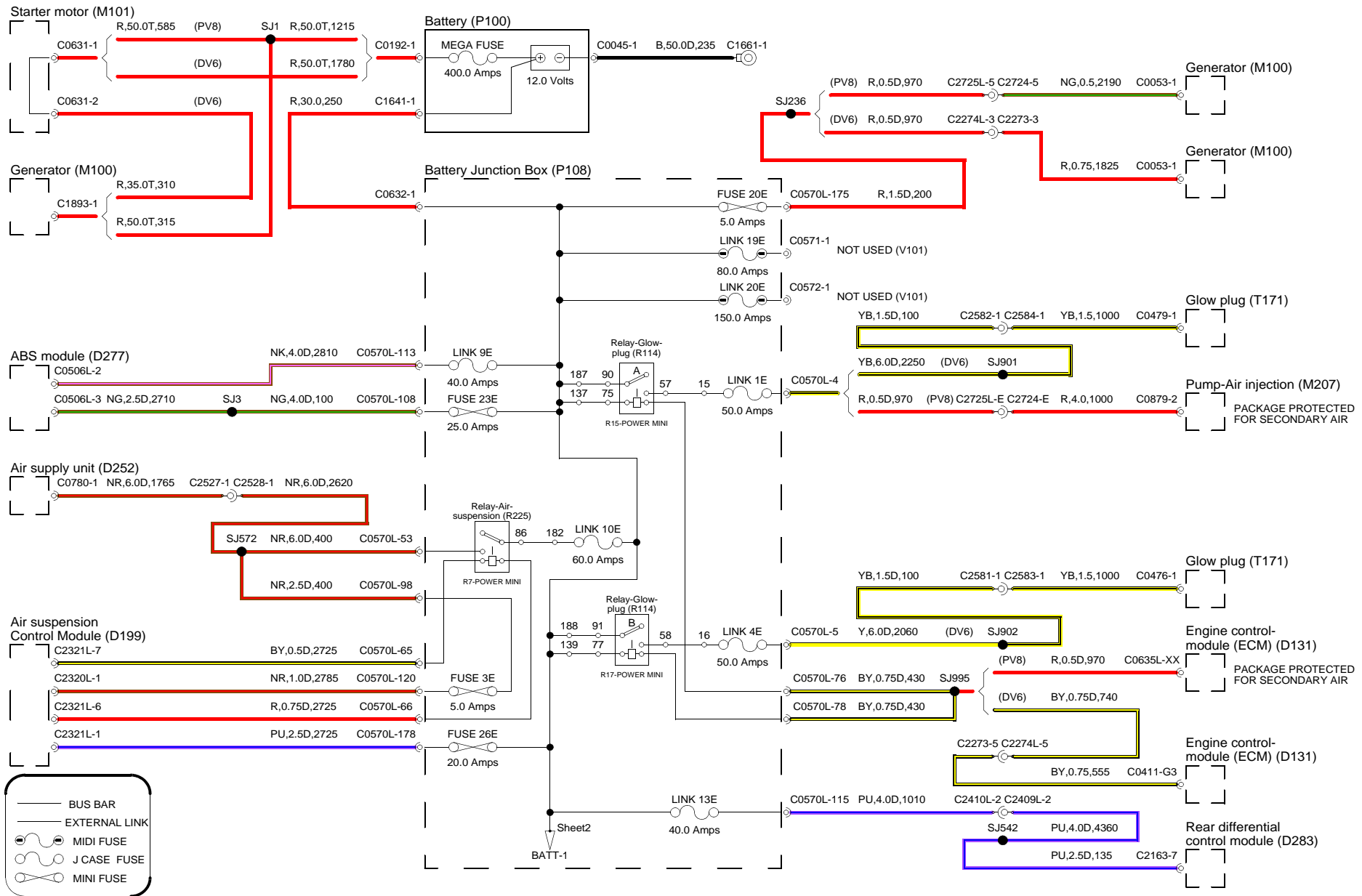

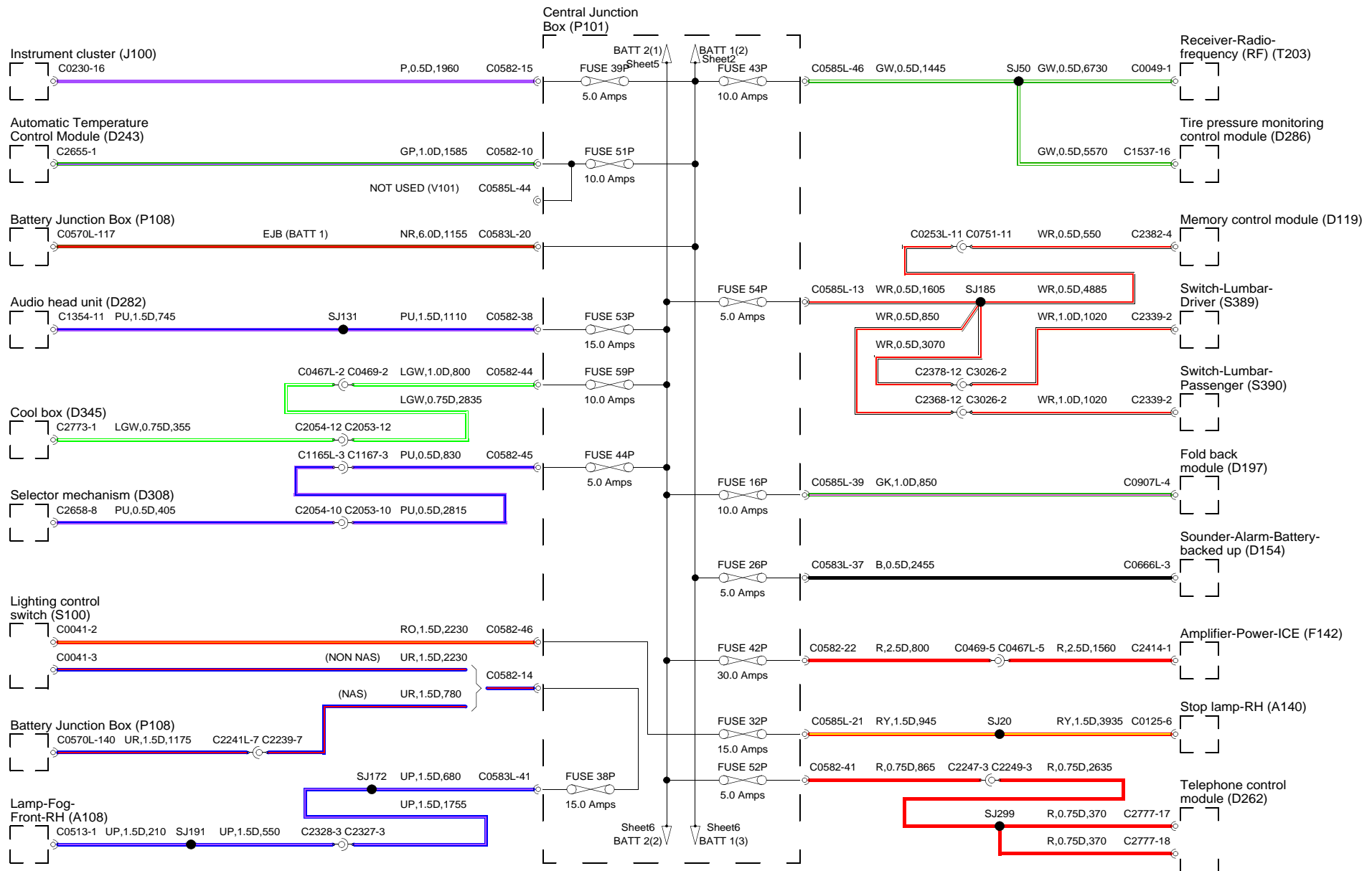

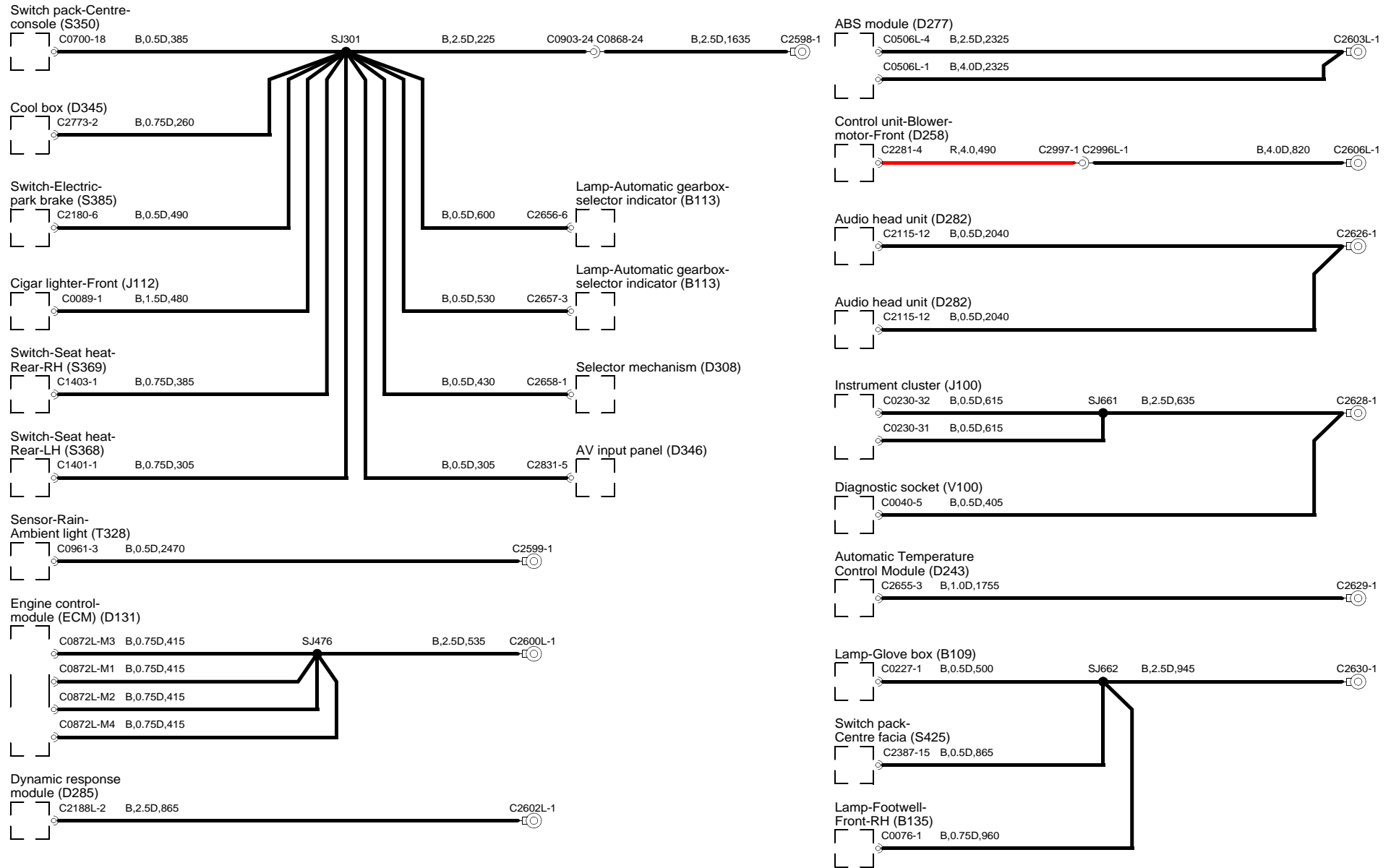

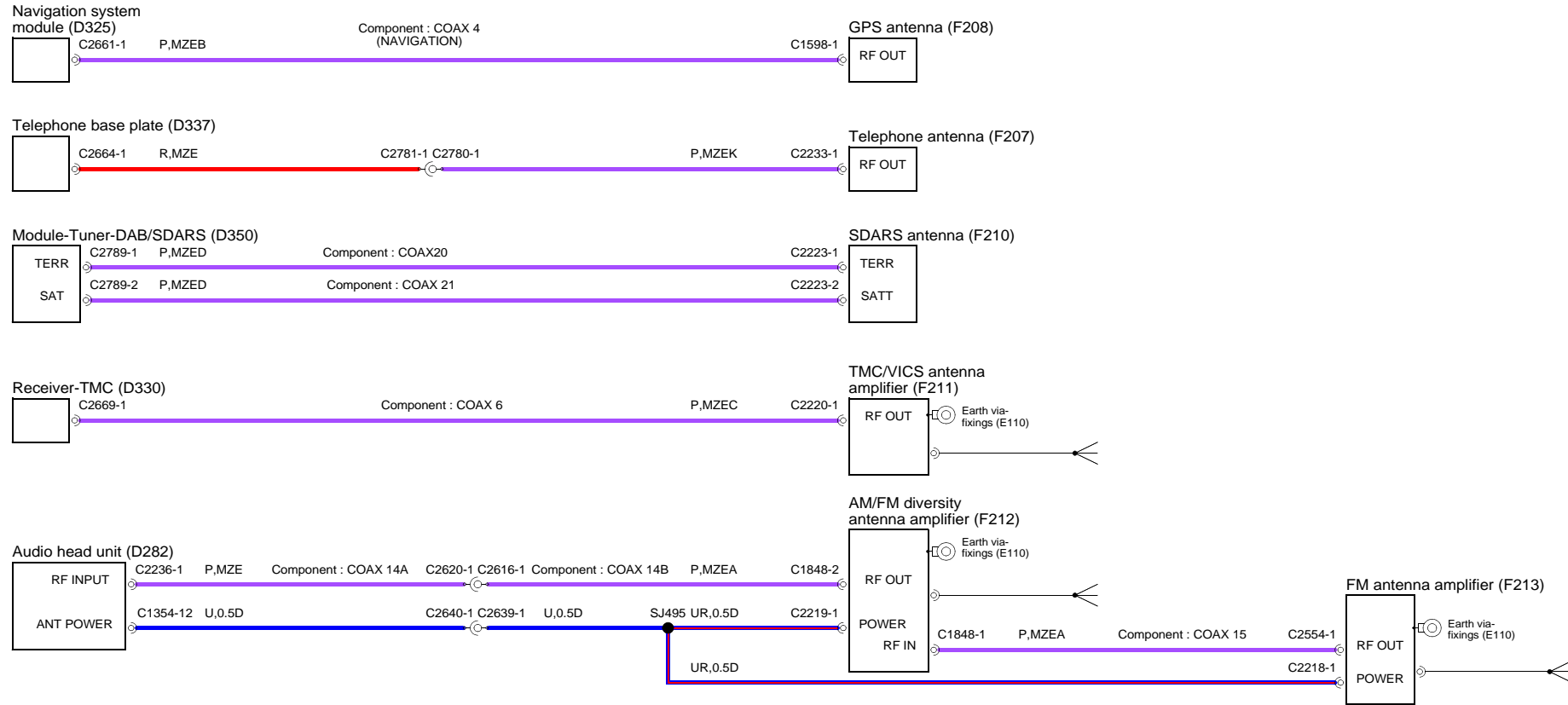

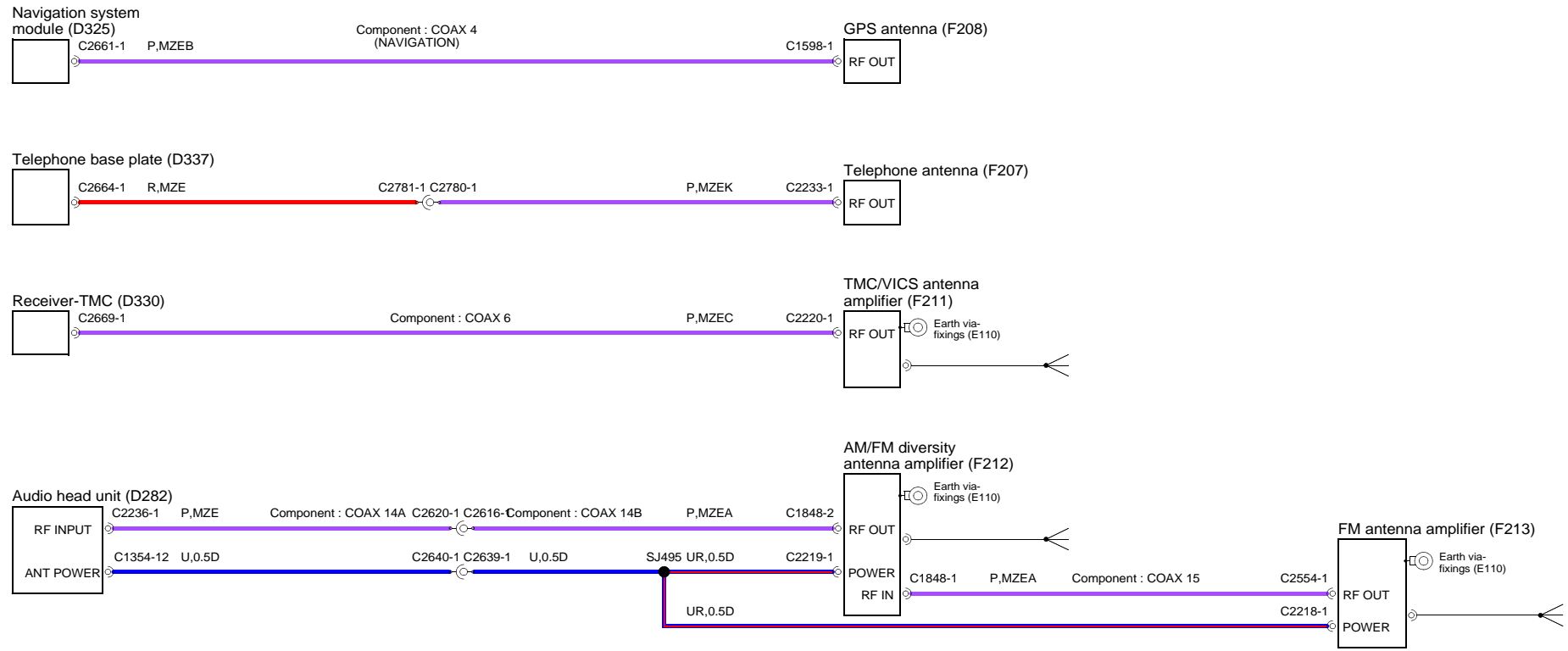

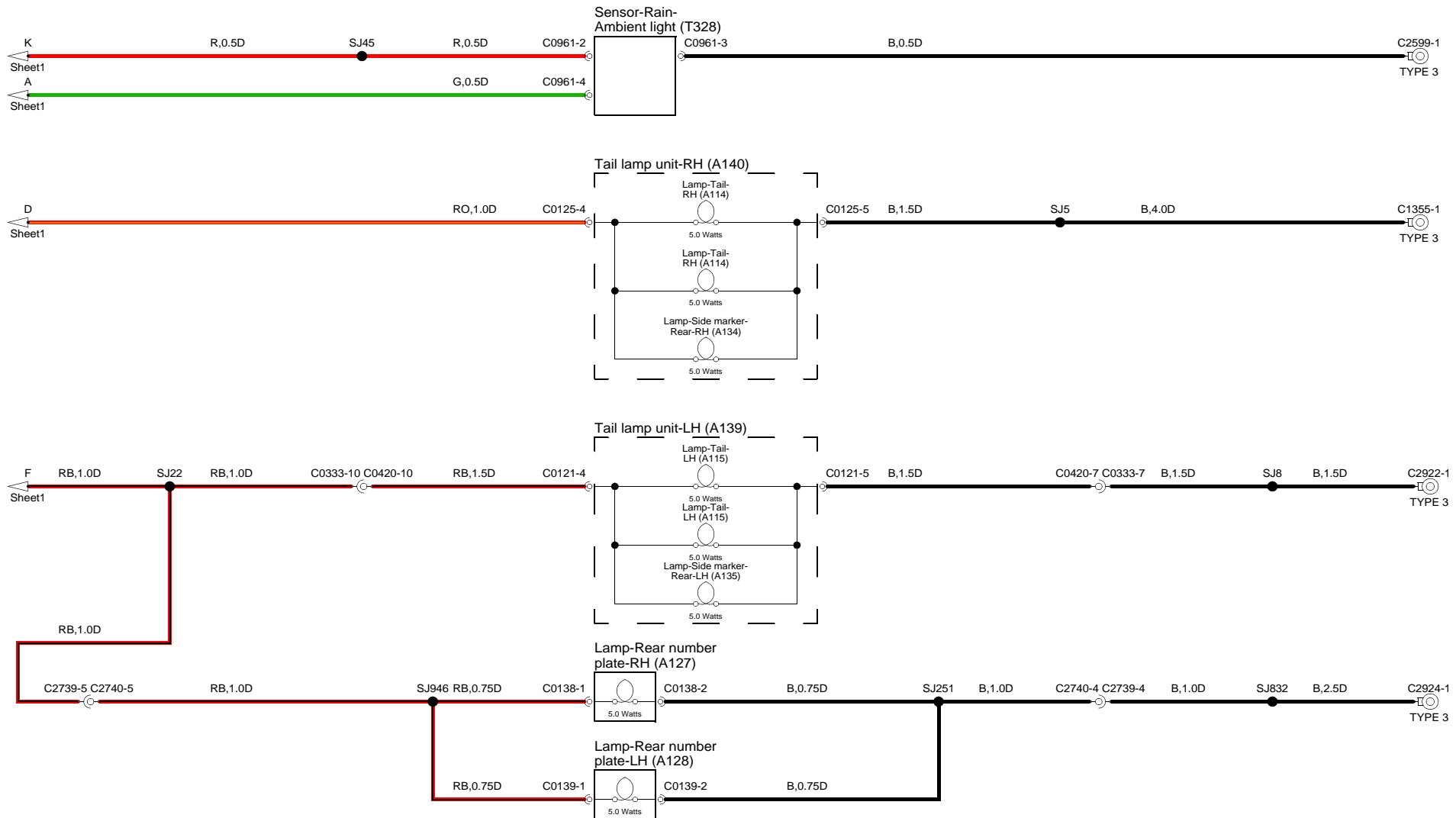

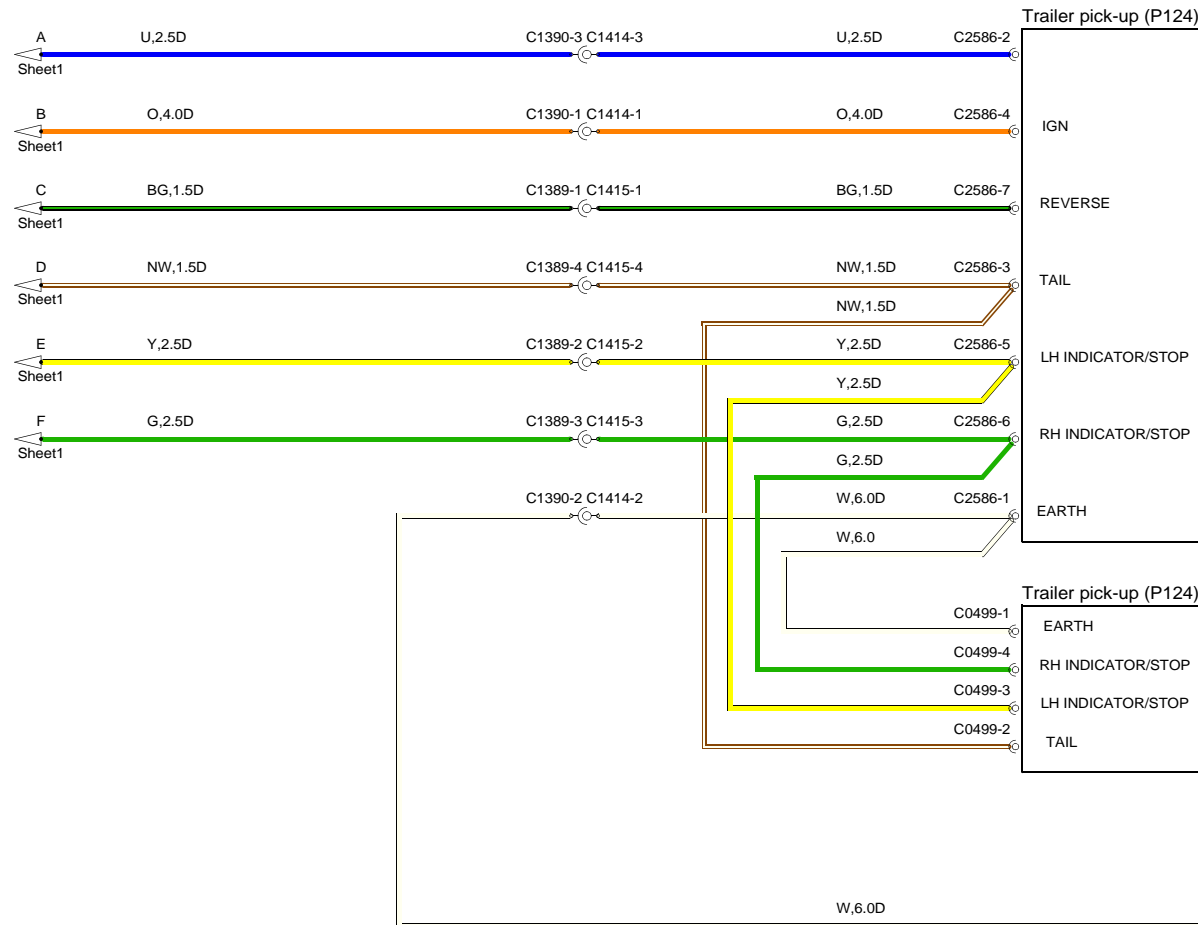

C0565-1  
 TYPE 3

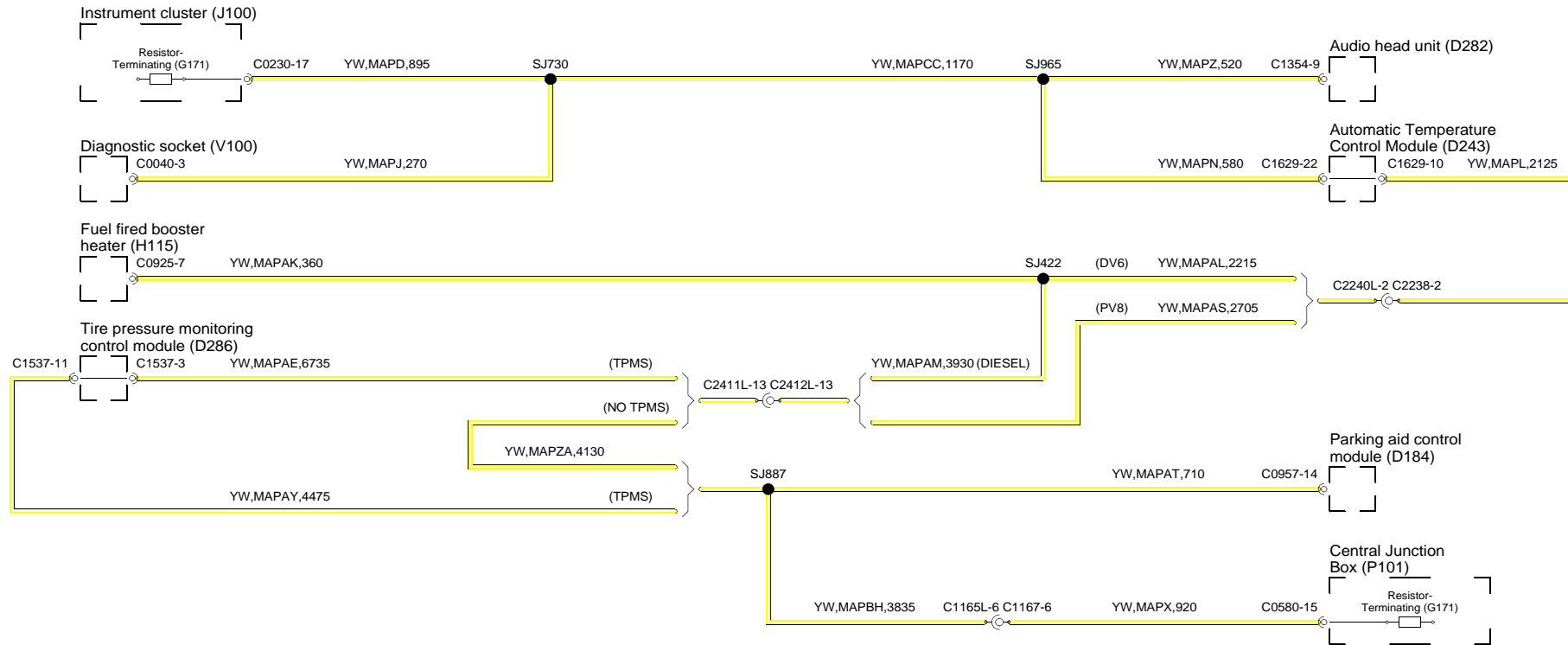

MS CAN\_H

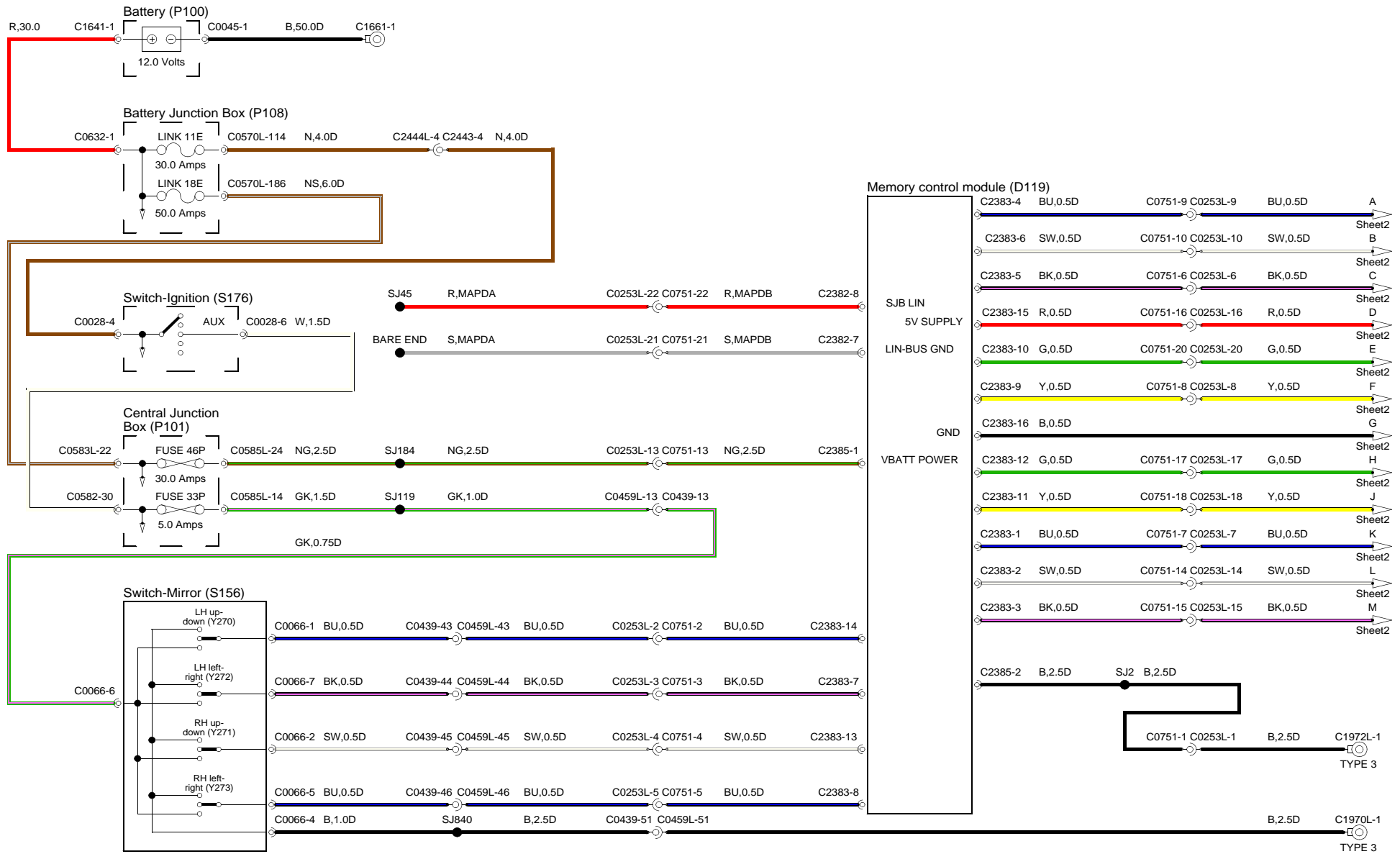

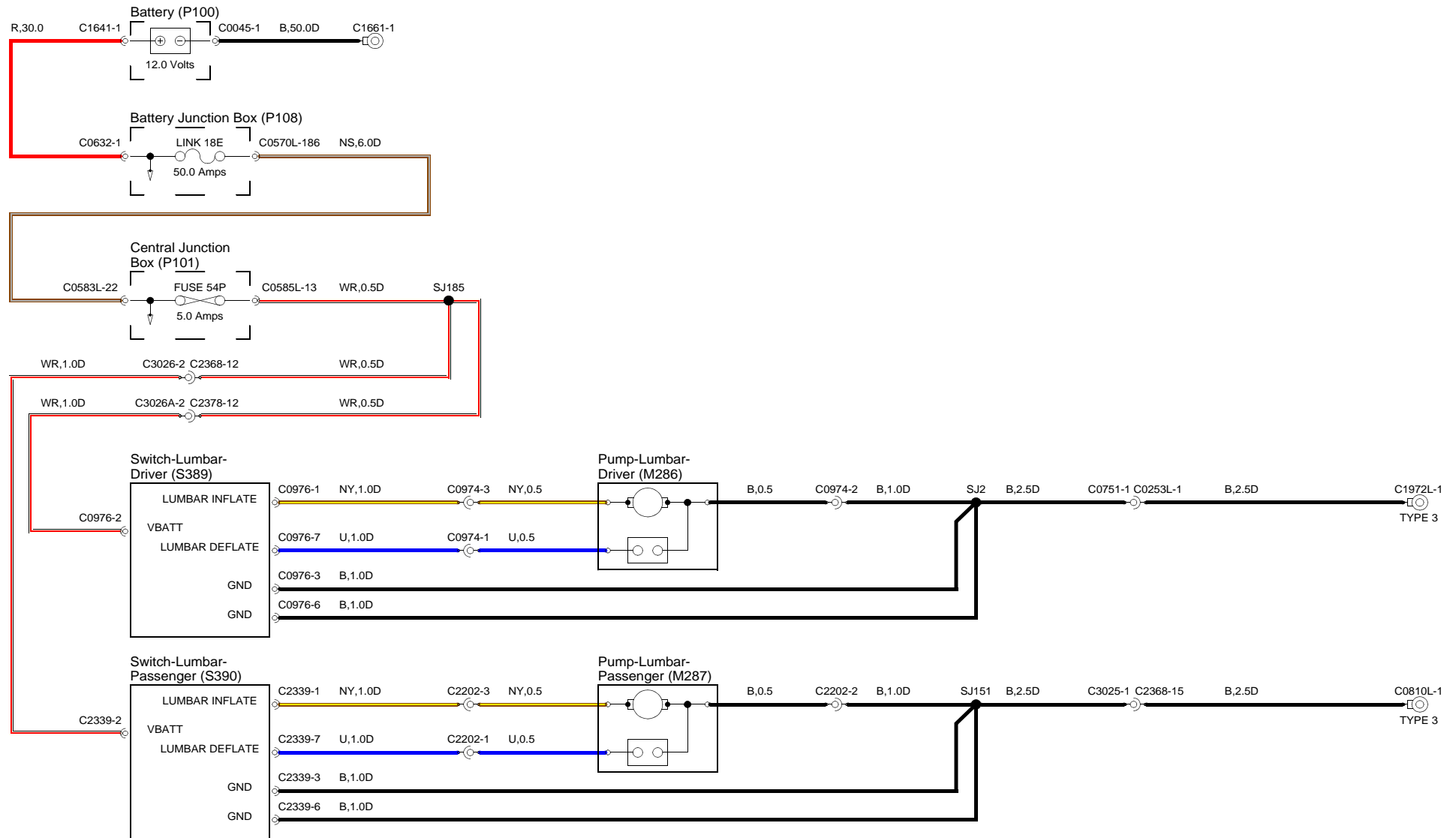

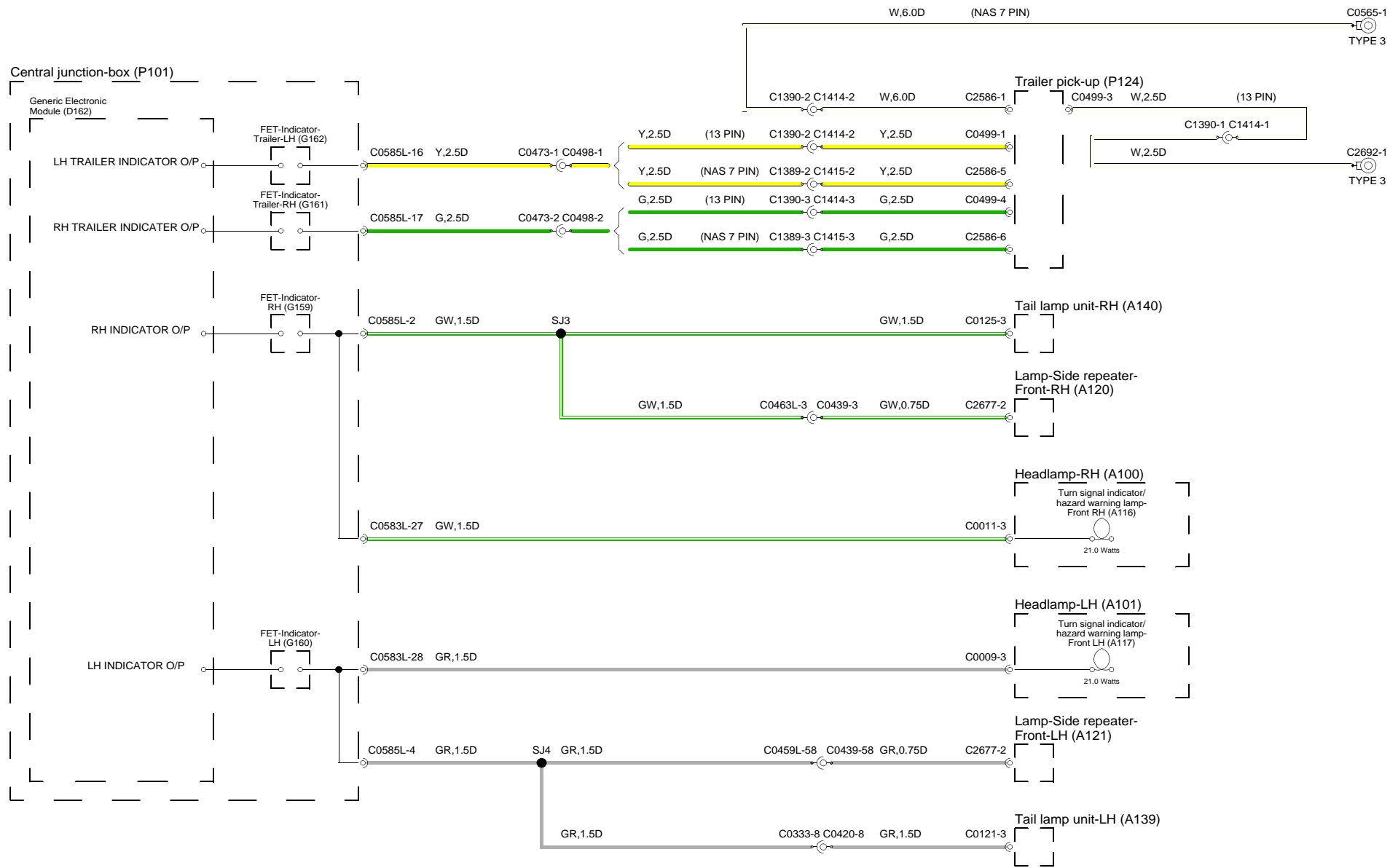

CLICK HERE TO **DOWNLOAD** THE COMPLETE MANUAL

- Thank you very much for reading the preview of the manual.
- You can download the complete manual from: [www.heydownloads.com](http://www.heydownloads.com) by clicking the link below



- Please note: If there is no response to CLICKING the link, please download this PDF first and then click on it.

CLICK HERE TO **DOWNLOAD** THE COMPLETE MANUAL