



RANGE ROVER

Electrical Circuit Diagrams

CLICK HERE TO **DOWNLOAD** THE COMPLETE MANUAL

- Thank you very much for reading the preview of the manual.
- You can download the complete manual from: www.heydownloads.com by clicking the link below



- Please note: If there is no response to CLICKING the link, please download this PDF first and then click on it.

CLICK HERE TO **DOWNLOAD** THE COMPLETE MANUAL

1 POWER DISTRIBUTION

Passenger Compartment Fuse Box

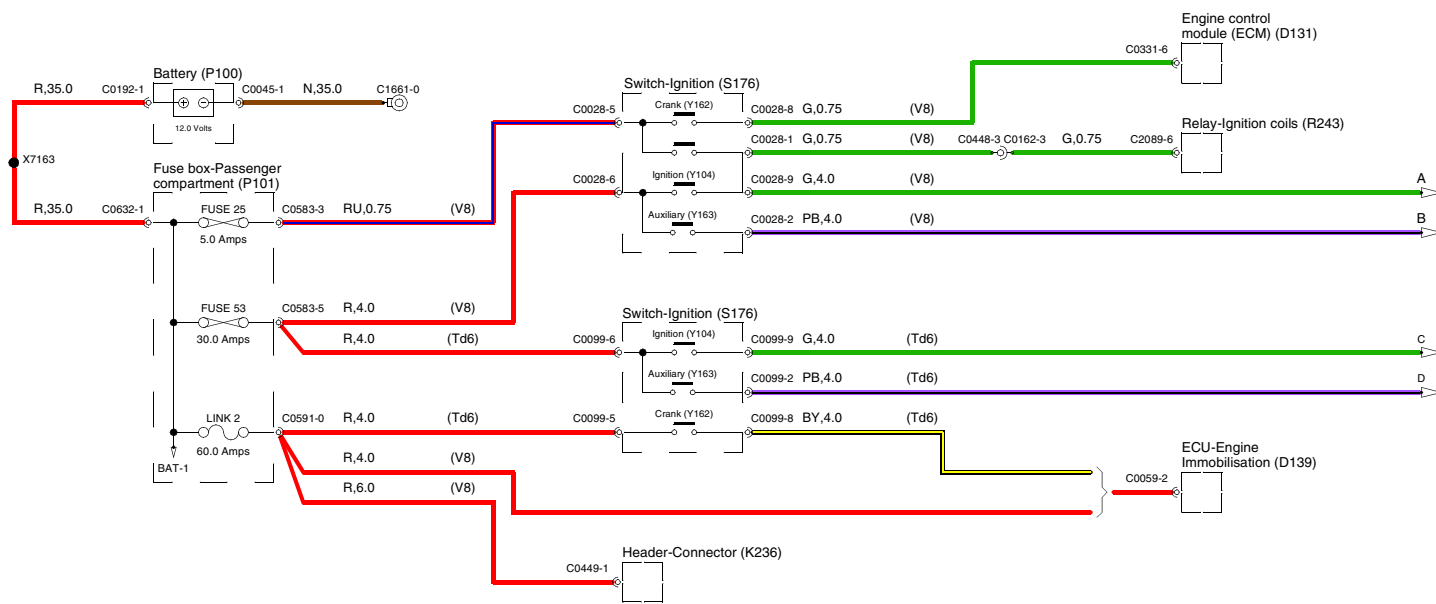

2 EARTH DISTRIBUTION

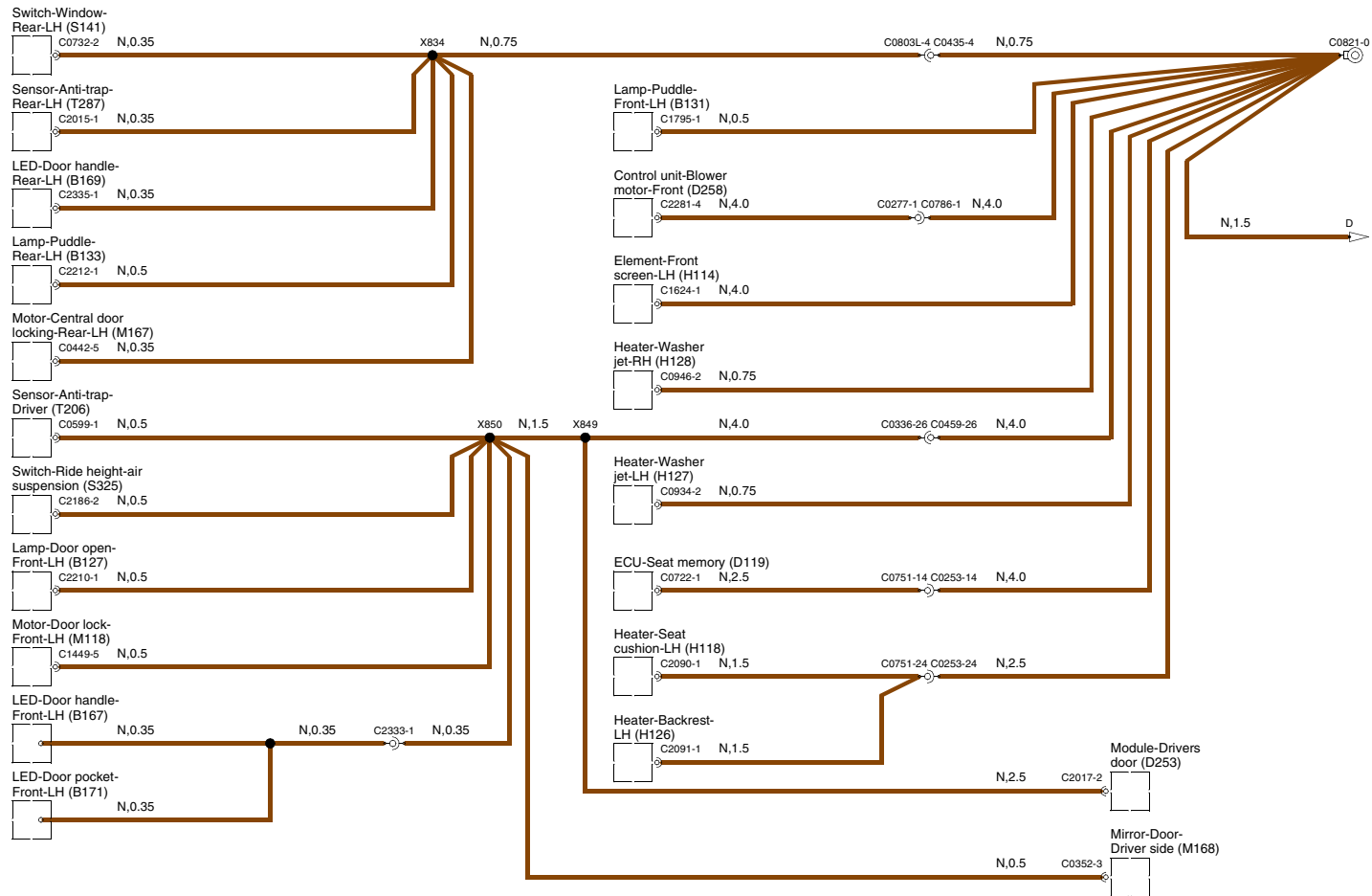

3 ENGINE IMMOBILISATION

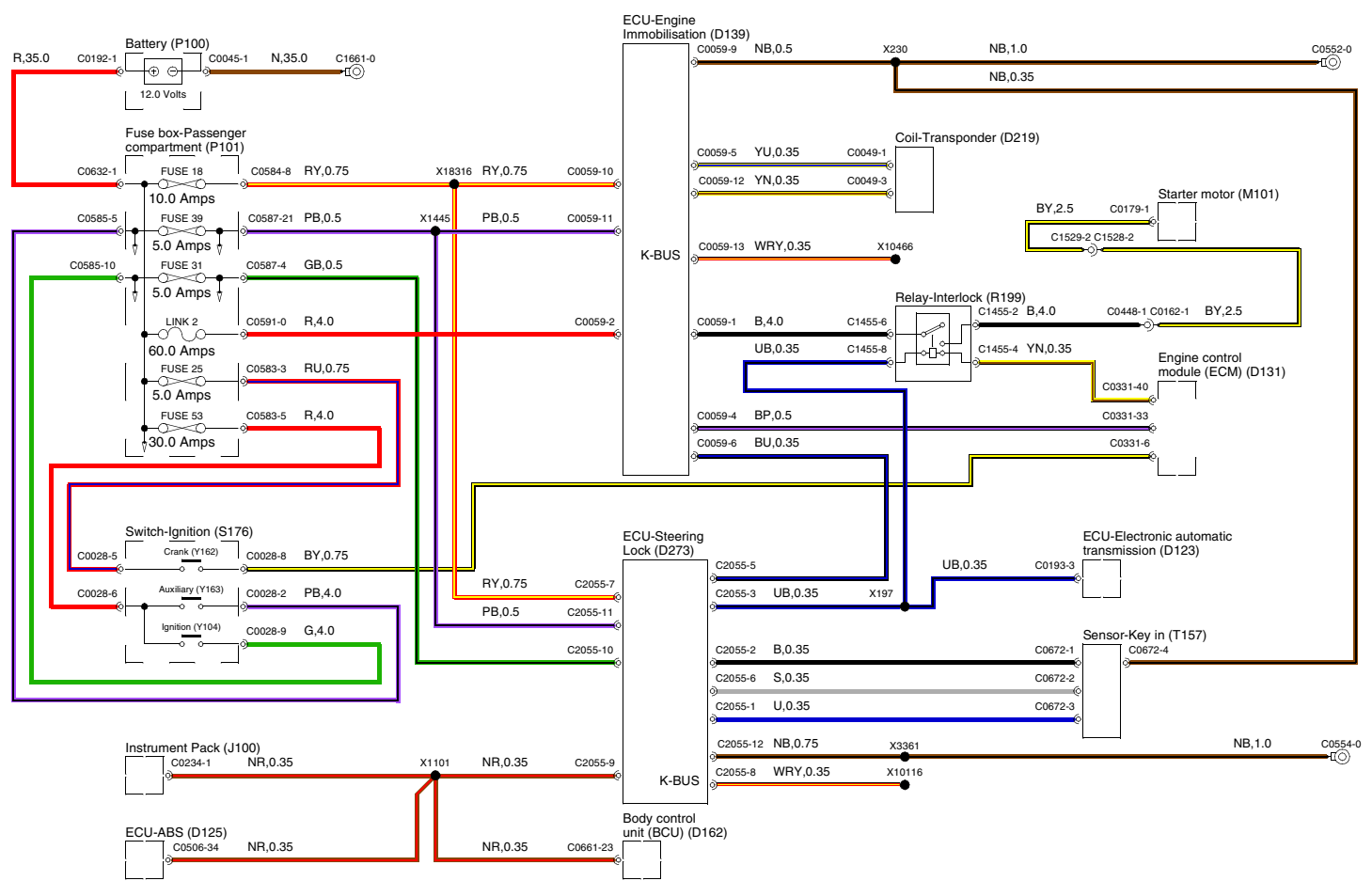

7 DOOR MIRRORS

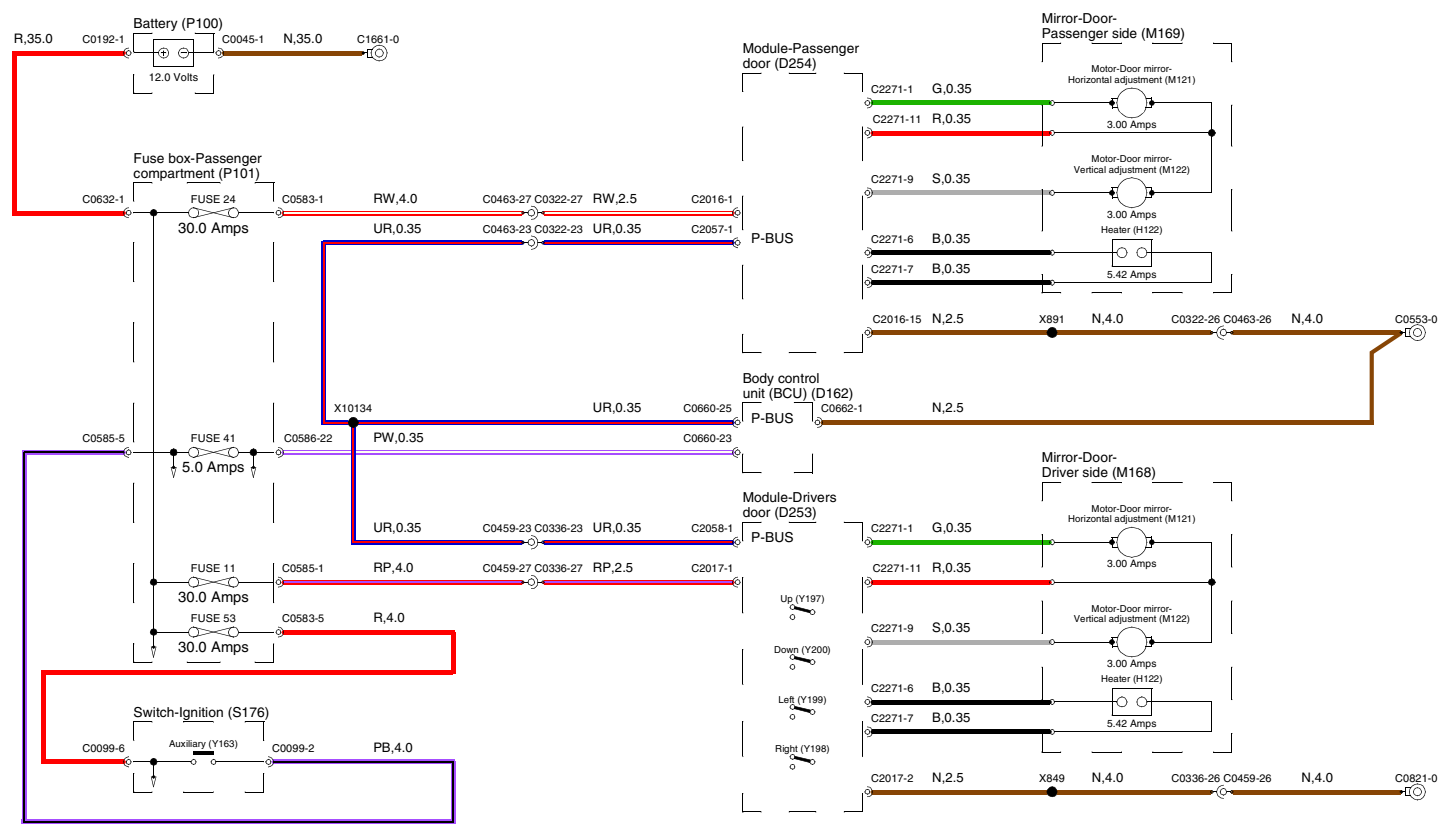

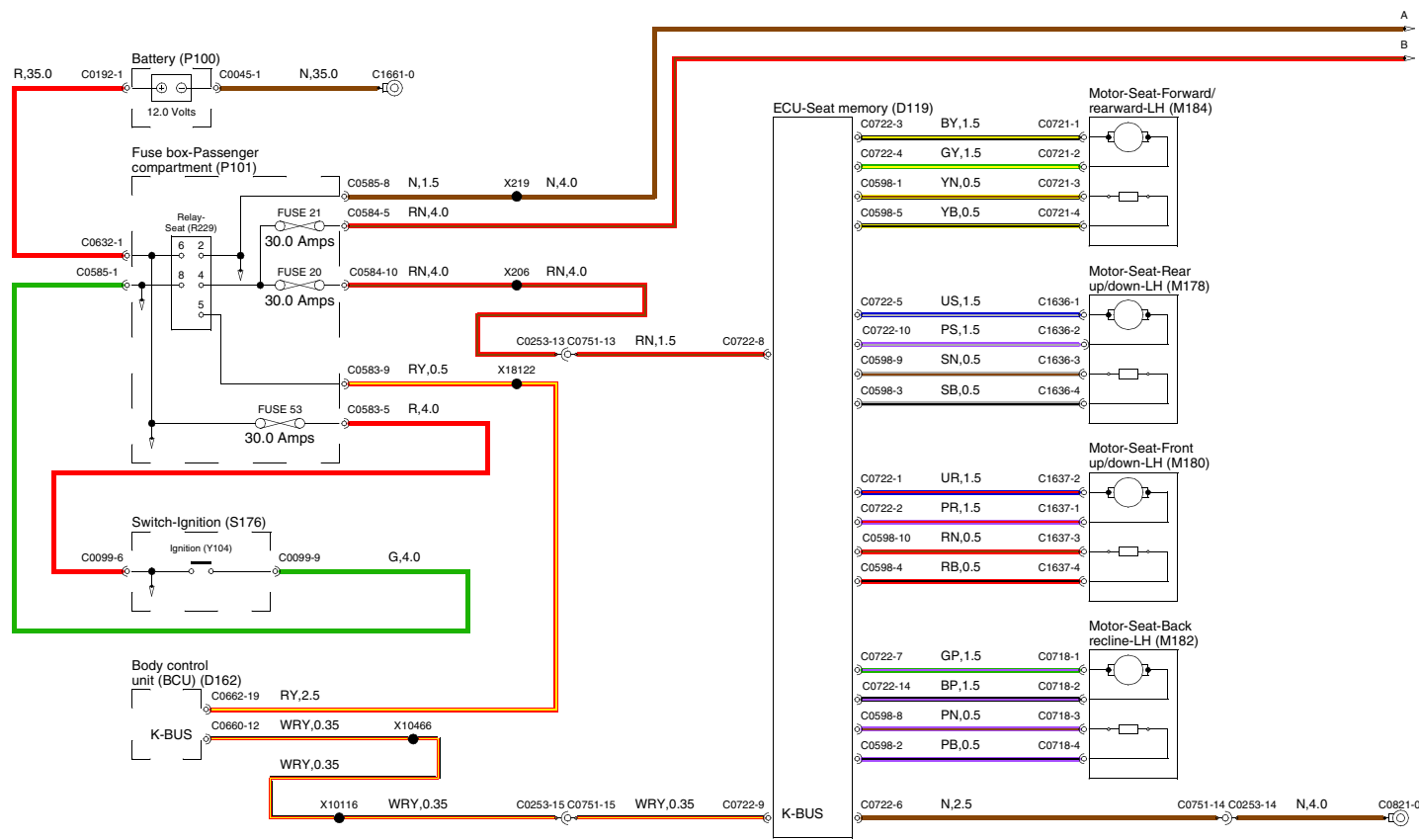

9 STEERING WHEEL

Adjustable

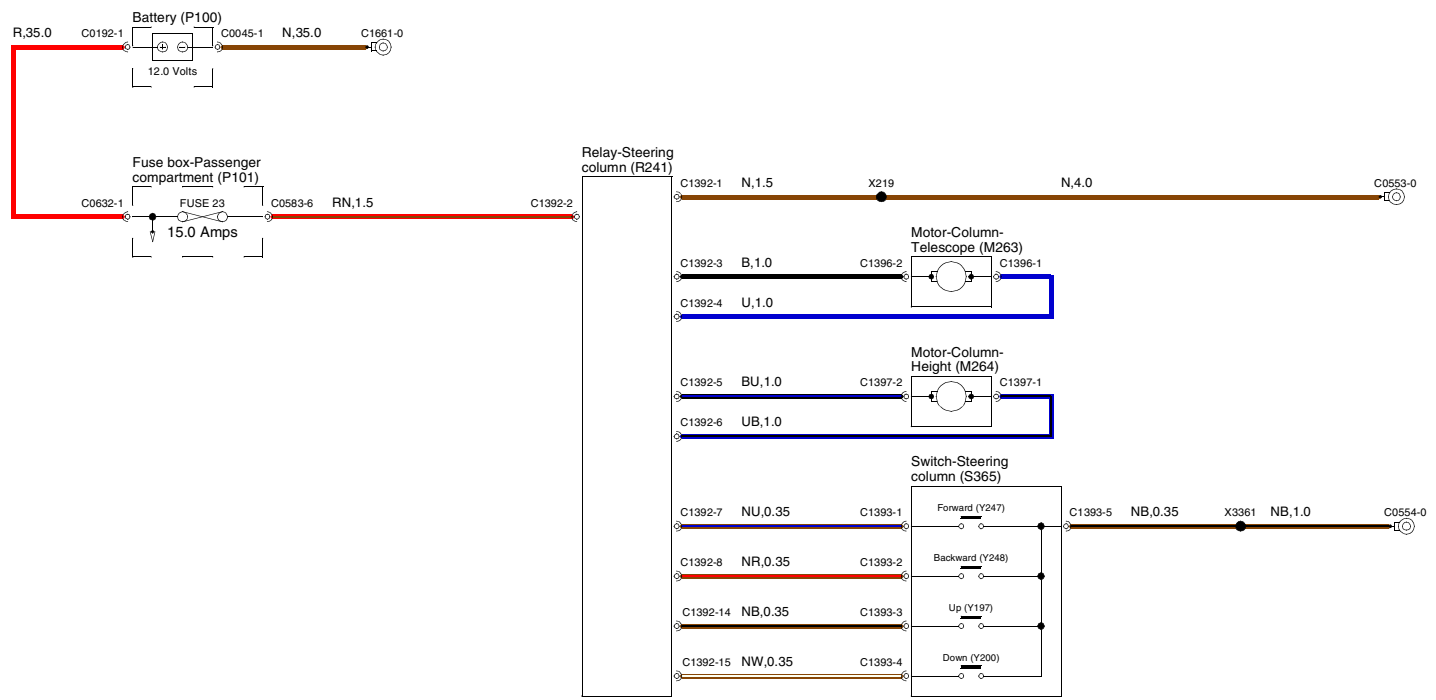

11 BODY CONTROL UNIT

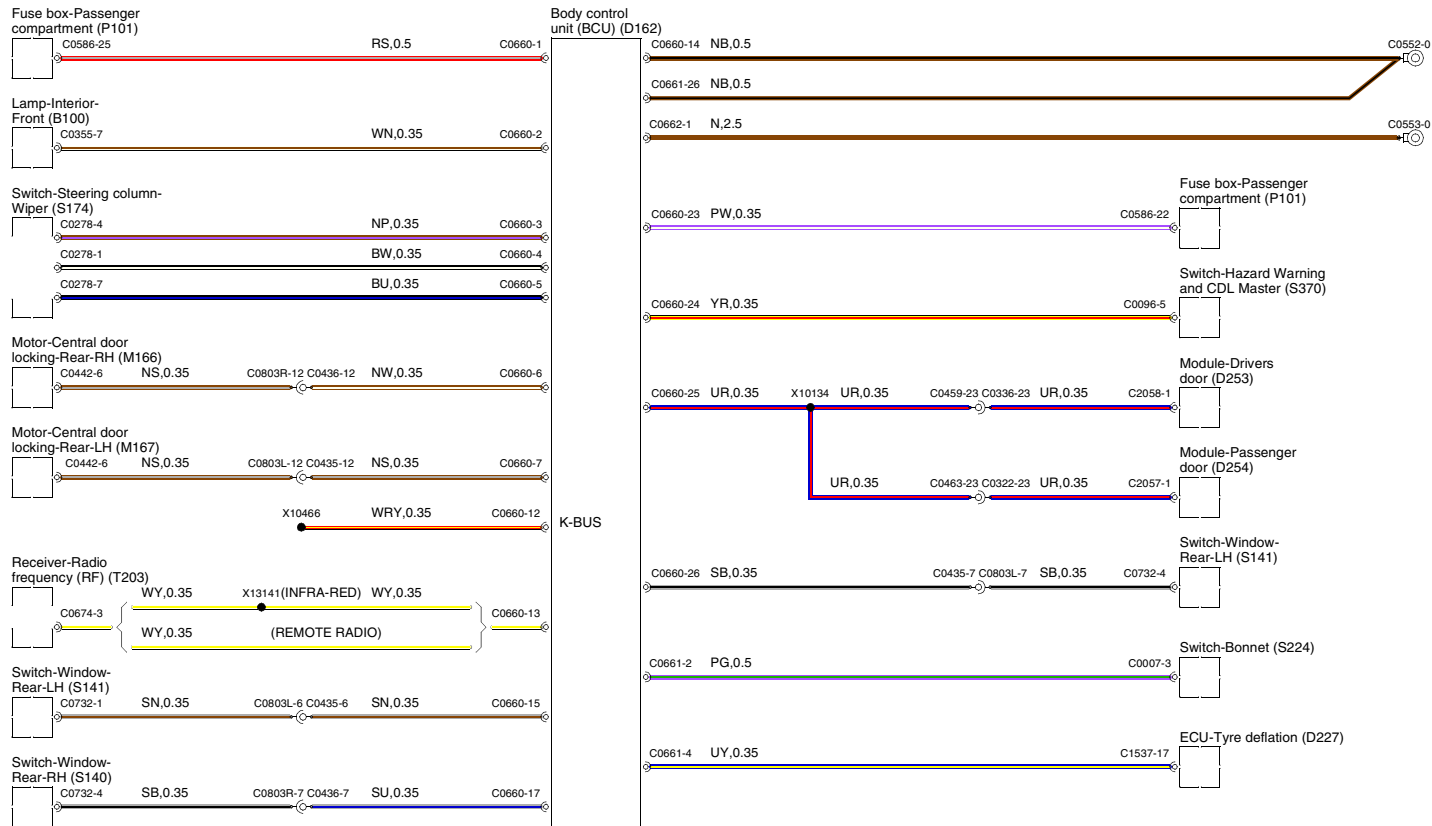

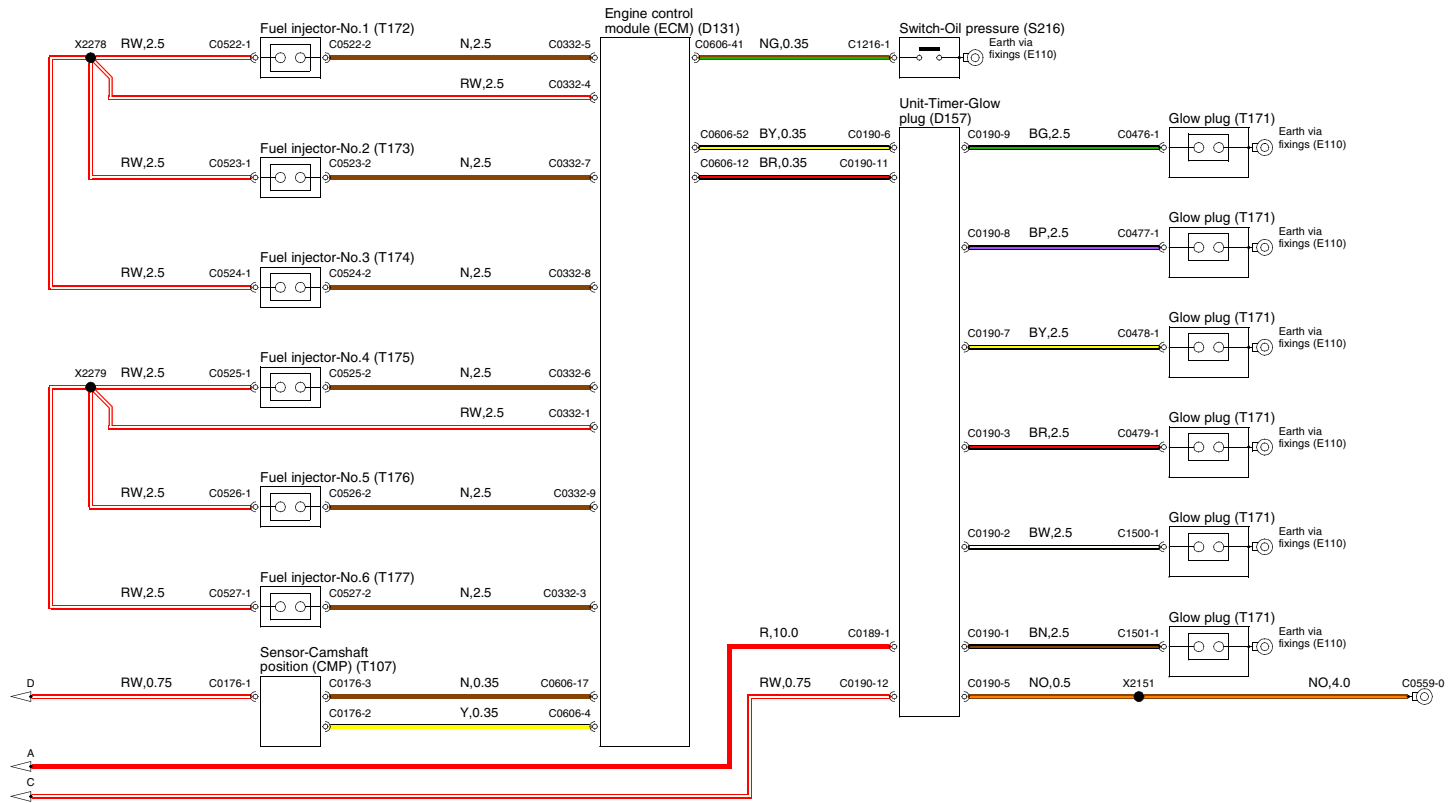

20 SECONDARY AIR INJECTION

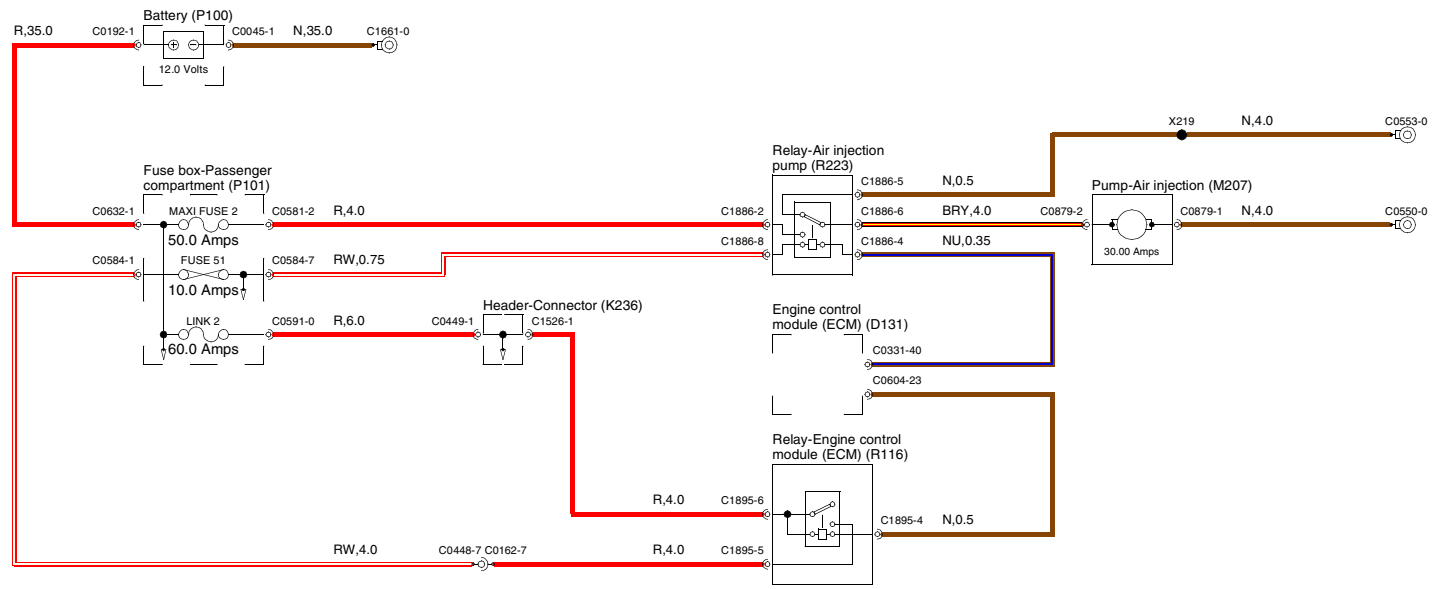

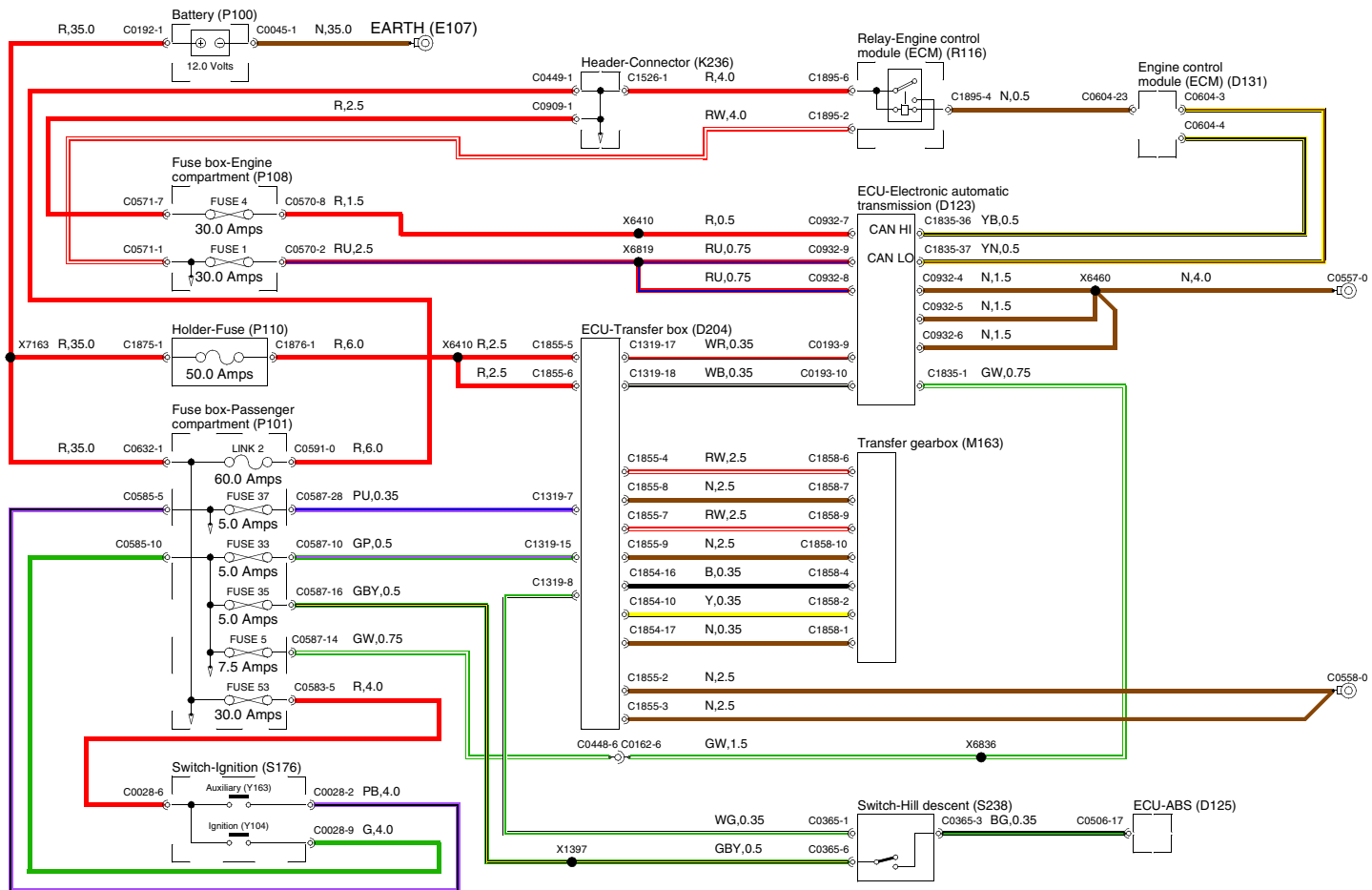

CLICK HERE TO **DOWNLOAD** THE COMPLETE MANUAL

- Thank you very much for reading the preview of the manual.
- You can download the complete manual from: www.heydownloads.com by clicking the link below



- Please note: If there is no response to CLICKING the link, please download this PDF first and then click on it.

CLICK HERE TO **DOWNLOAD** THE COMPLETE MANUAL

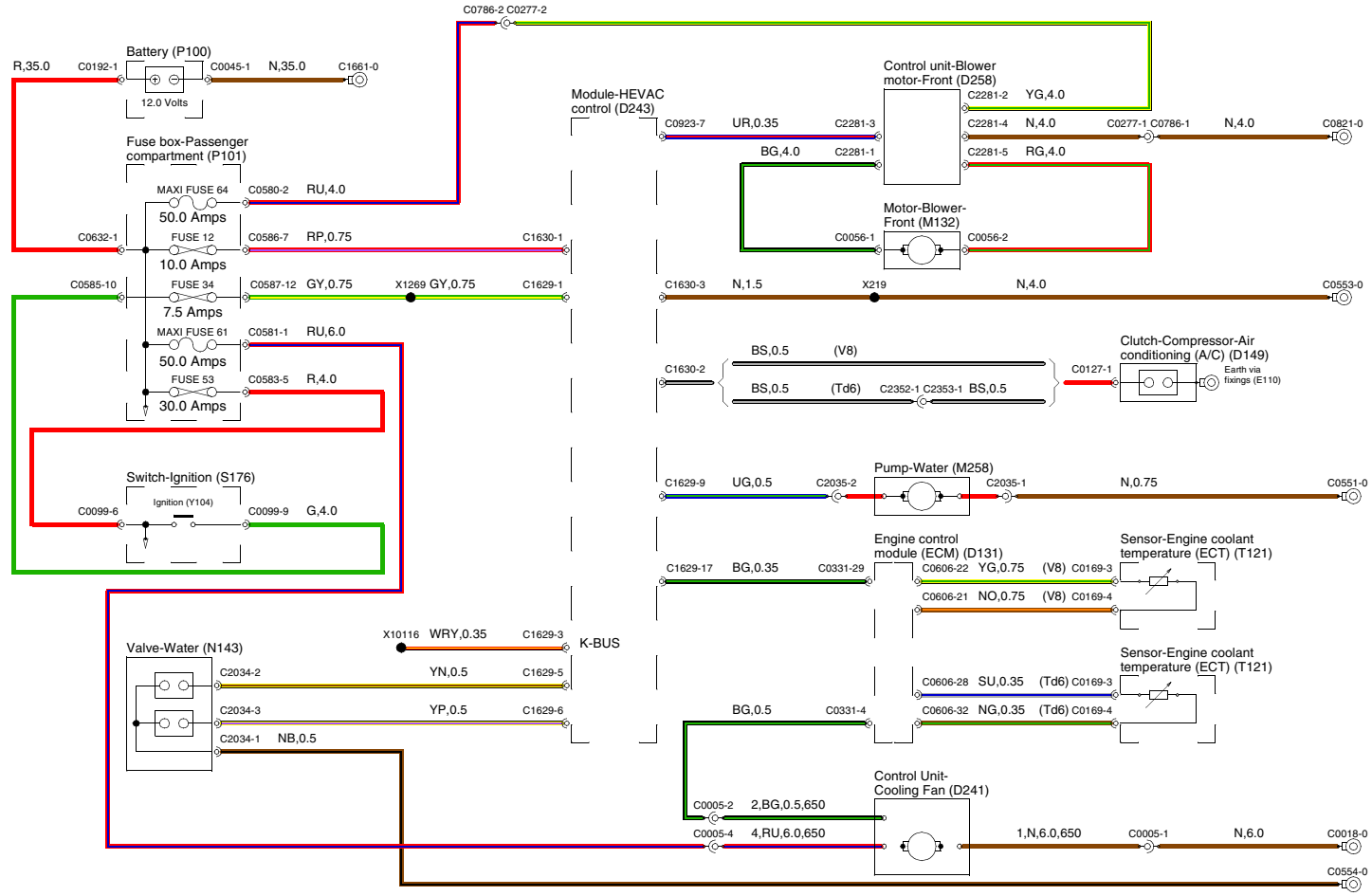

40 HEATED REAR SCREEN

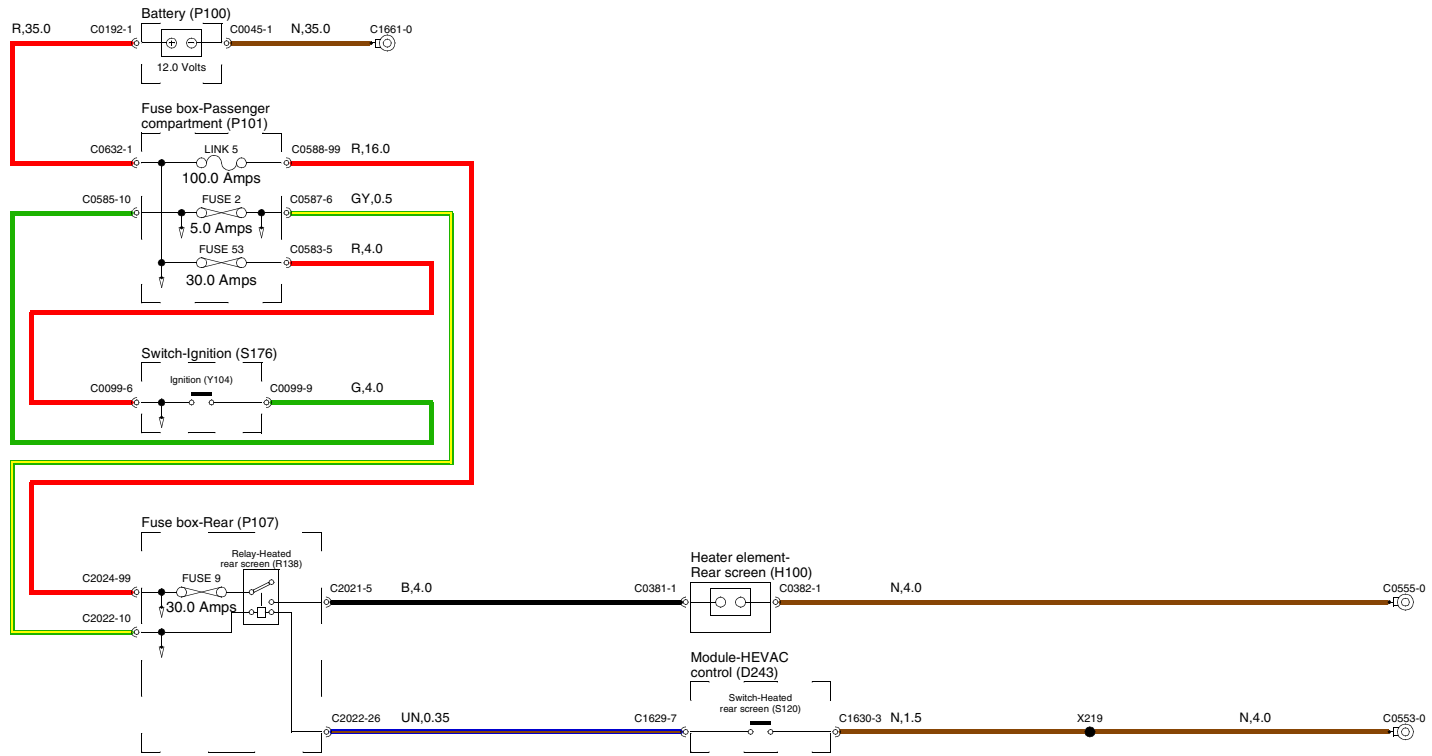

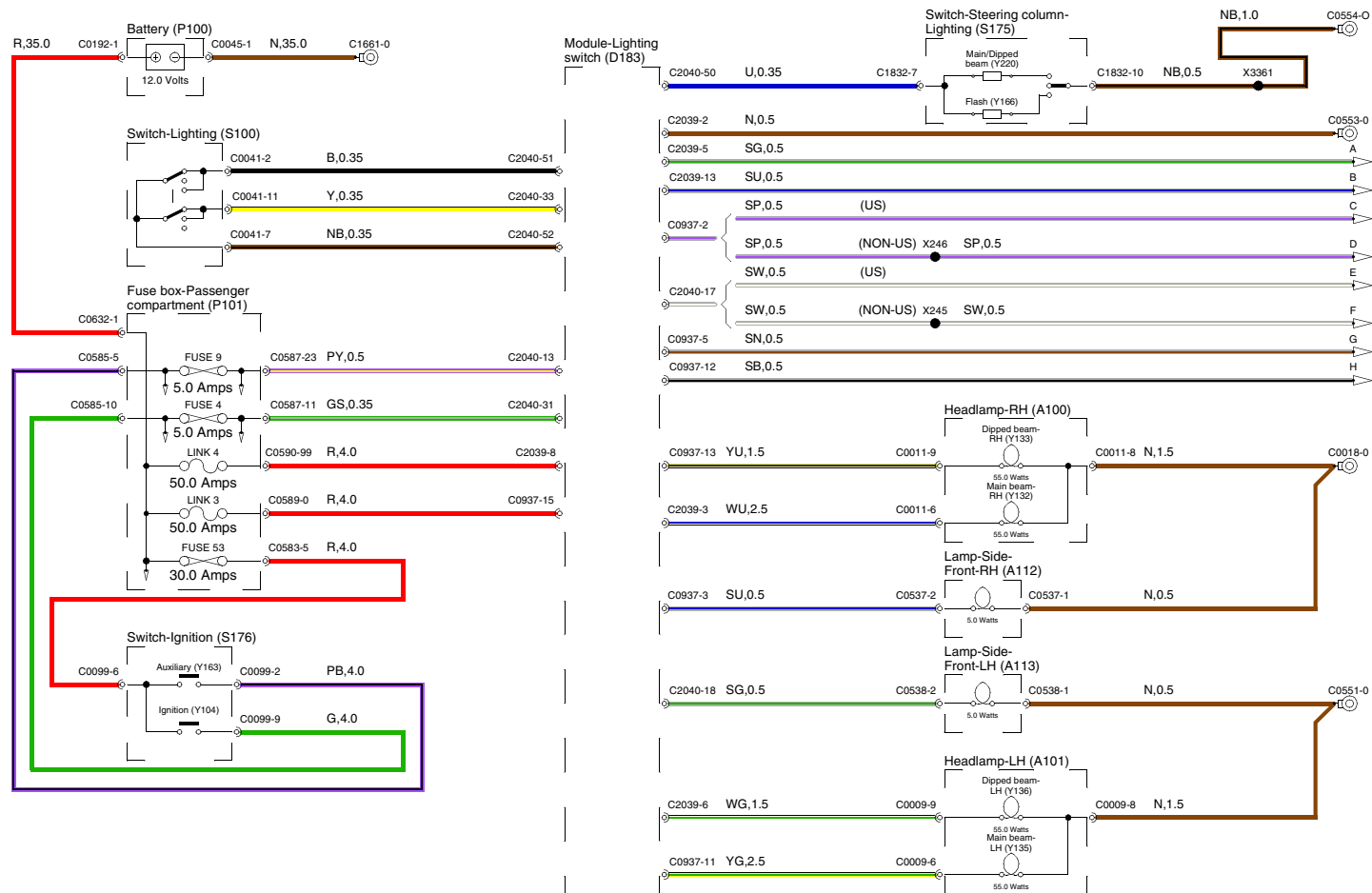

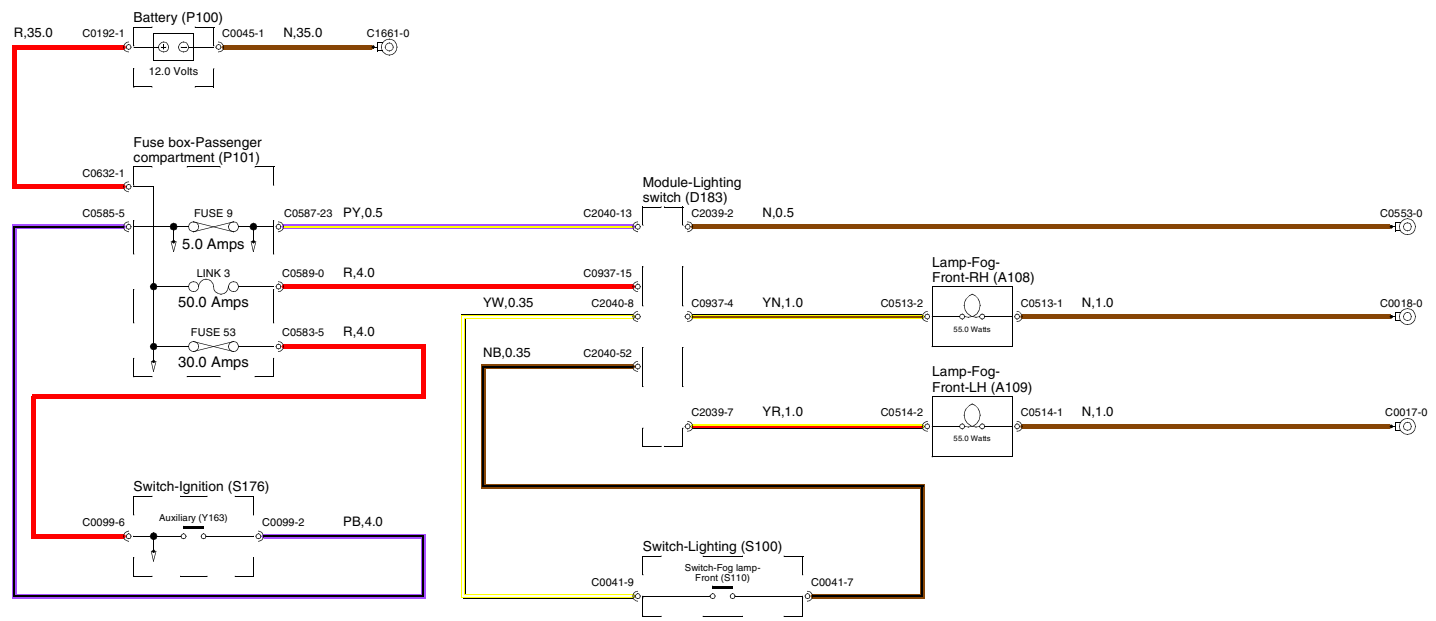

46 INTERIOR ILLUMINATION

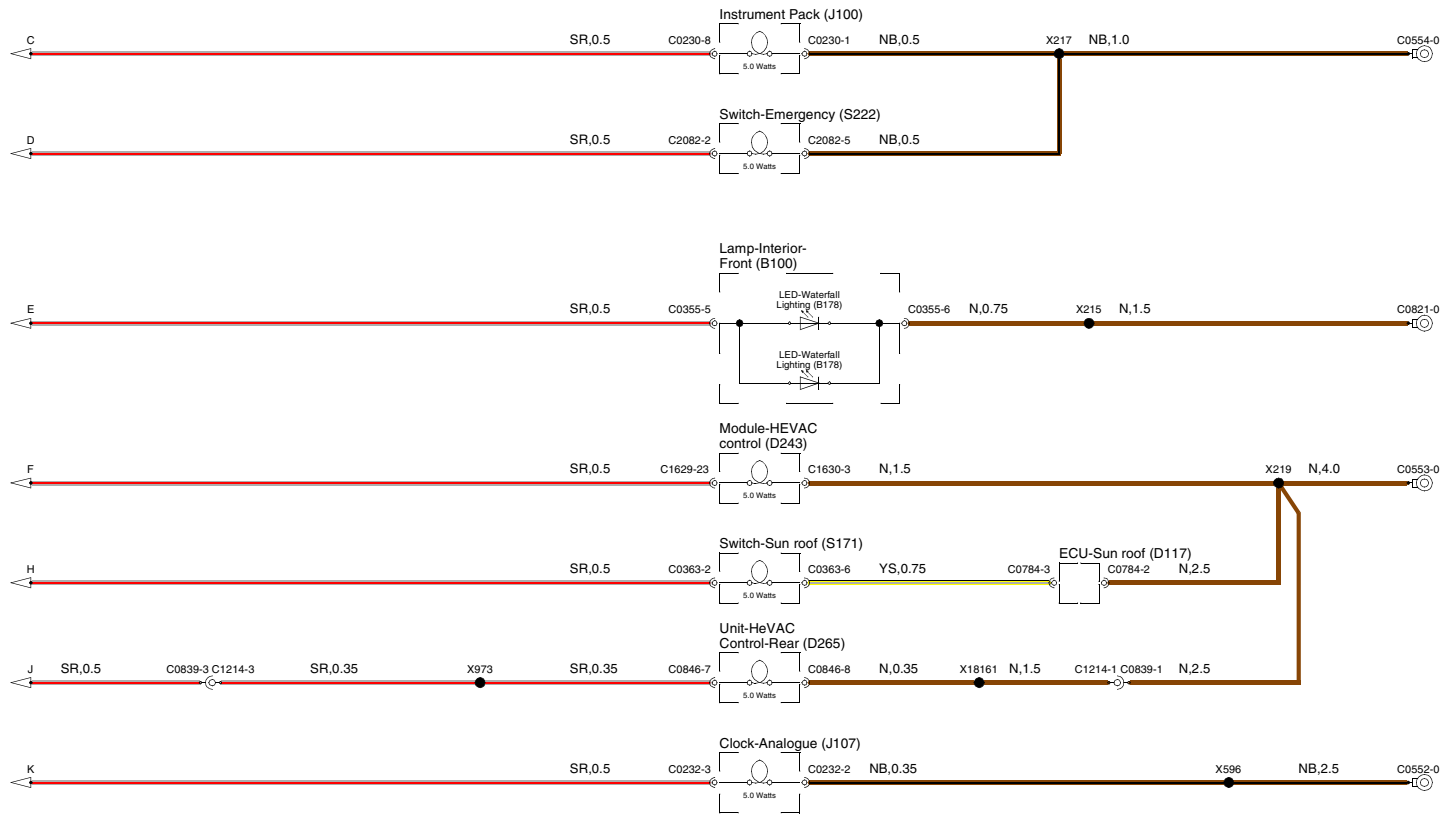

48 CLOCK

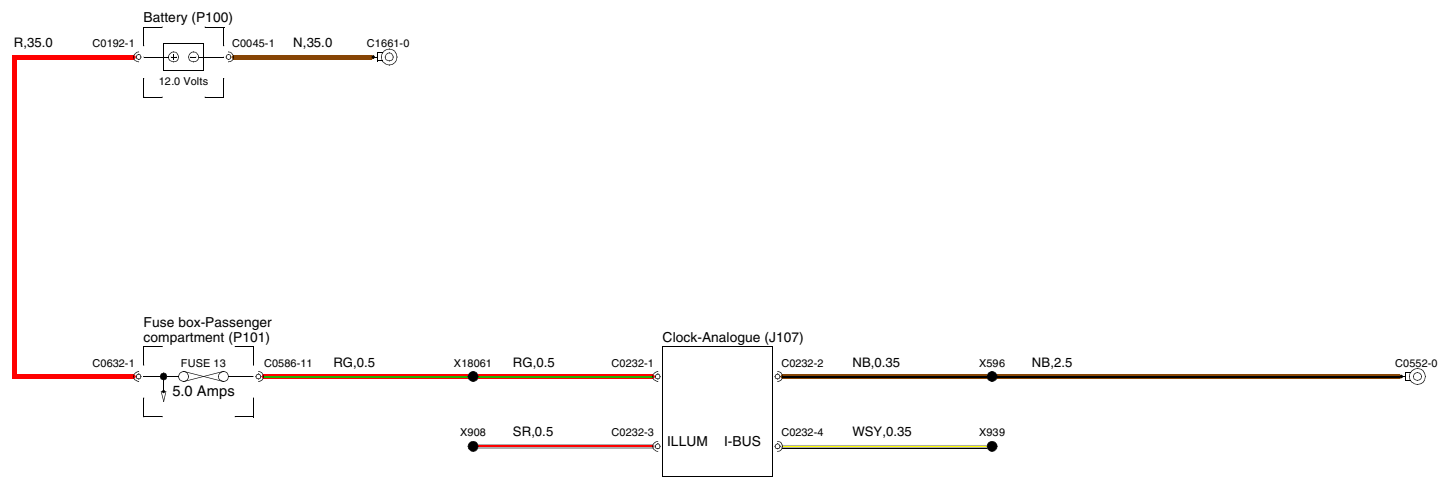

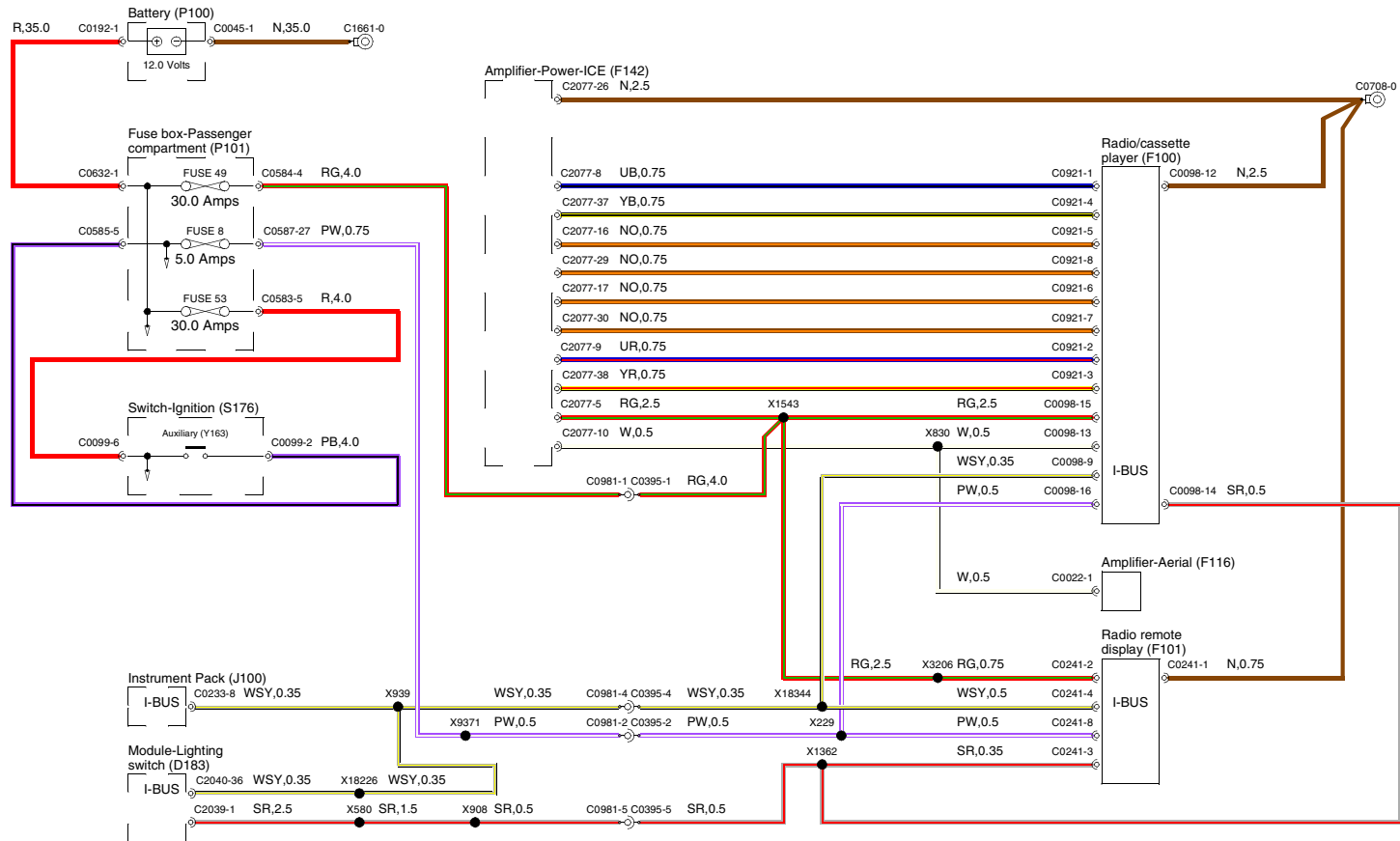

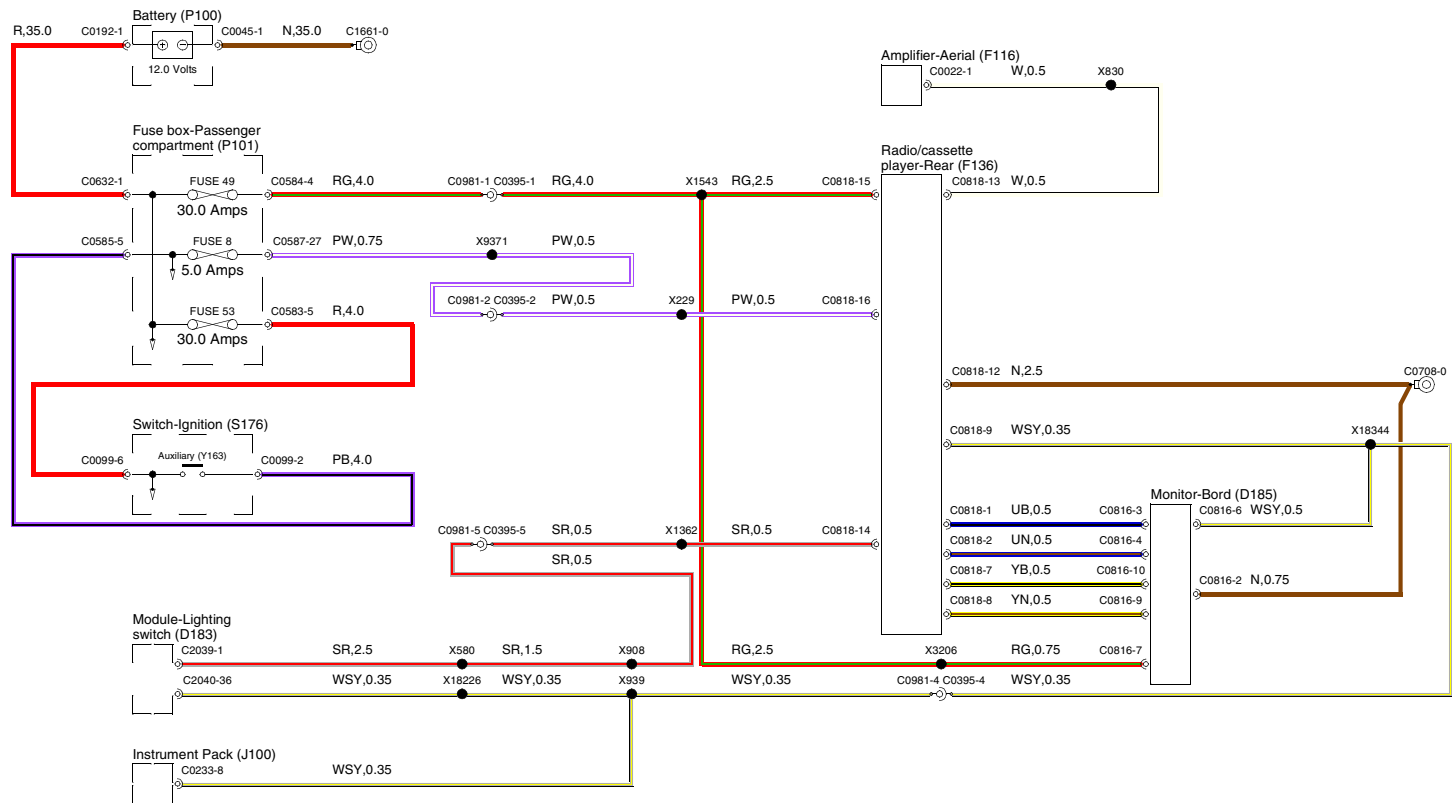

65 SPLICES AND CENTRE TAPS

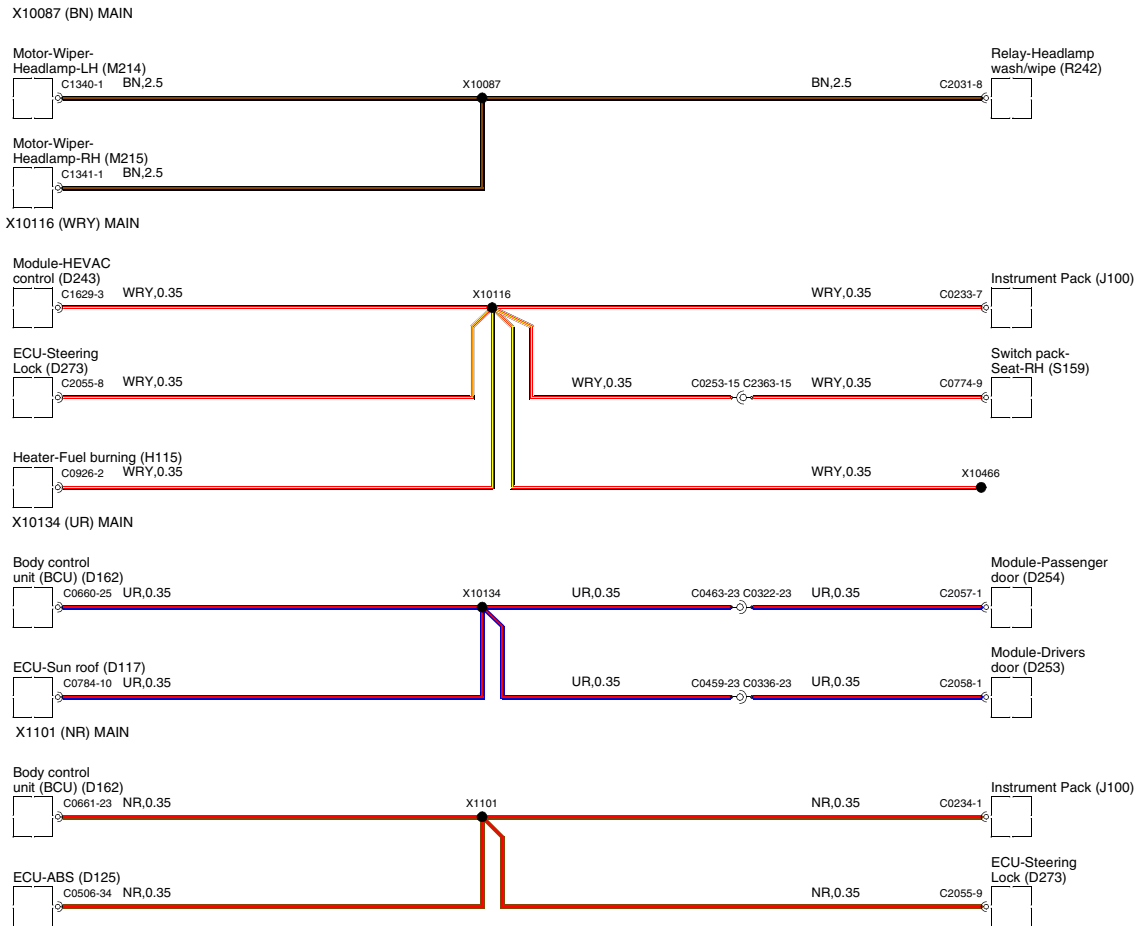

65 SPLICES AND CENTRE TAPS

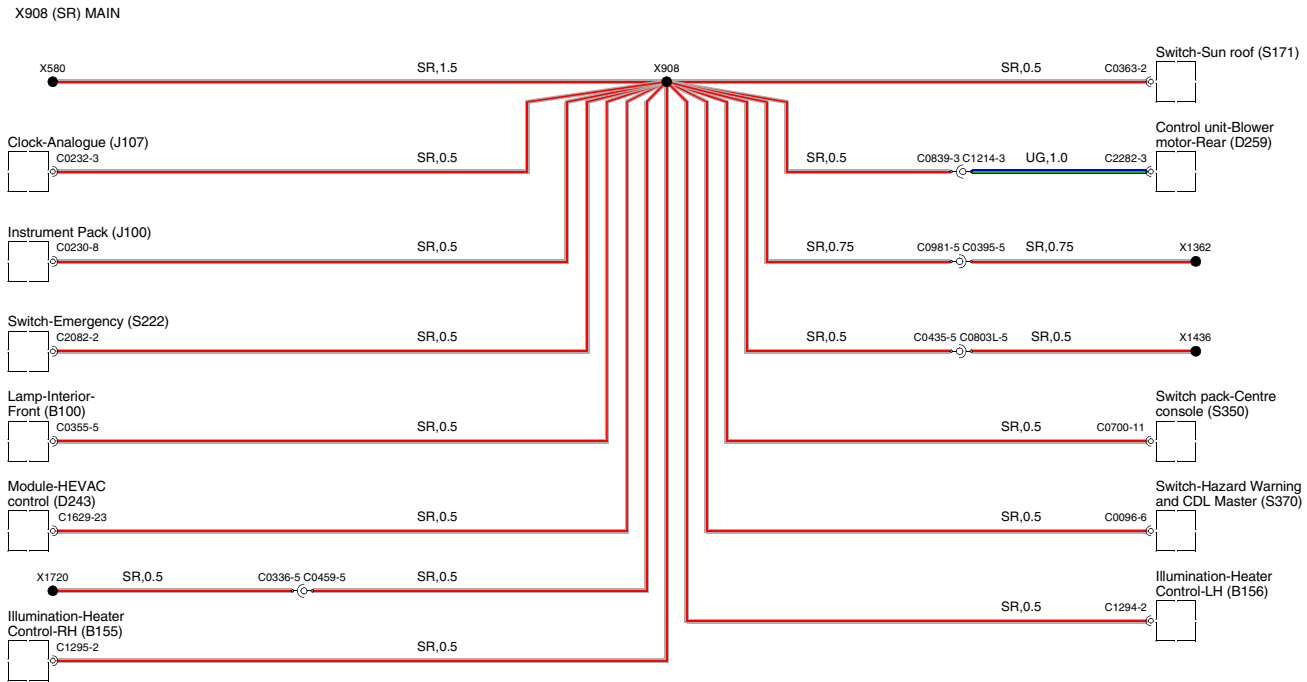

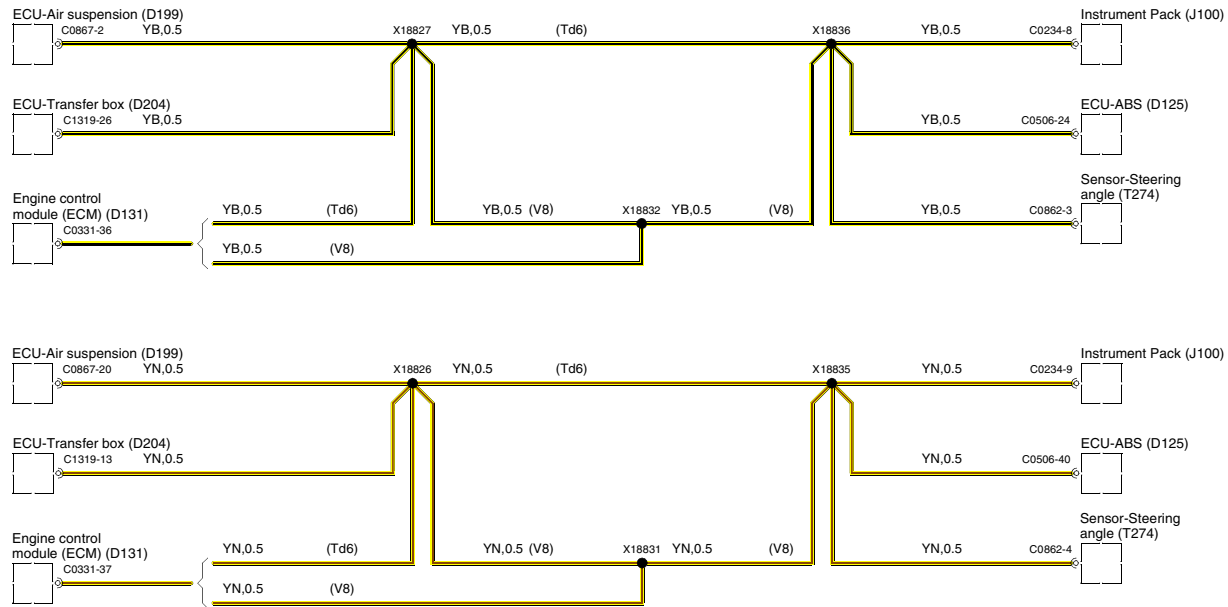

CLICK HERE TO **DOWNLOAD** THE COMPLETE MANUAL

- Thank you very much for reading the preview of the manual.
- You can download the complete manual from: www.heydownloads.com by clicking the link below



- Please note: If there is no response to CLICKING the link, please download this PDF first and then click on it.

CLICK HERE TO **DOWNLOAD** THE COMPLETE MANUAL