

# Grove GMK 6300L

## Operating Manual Part 1 – Driving

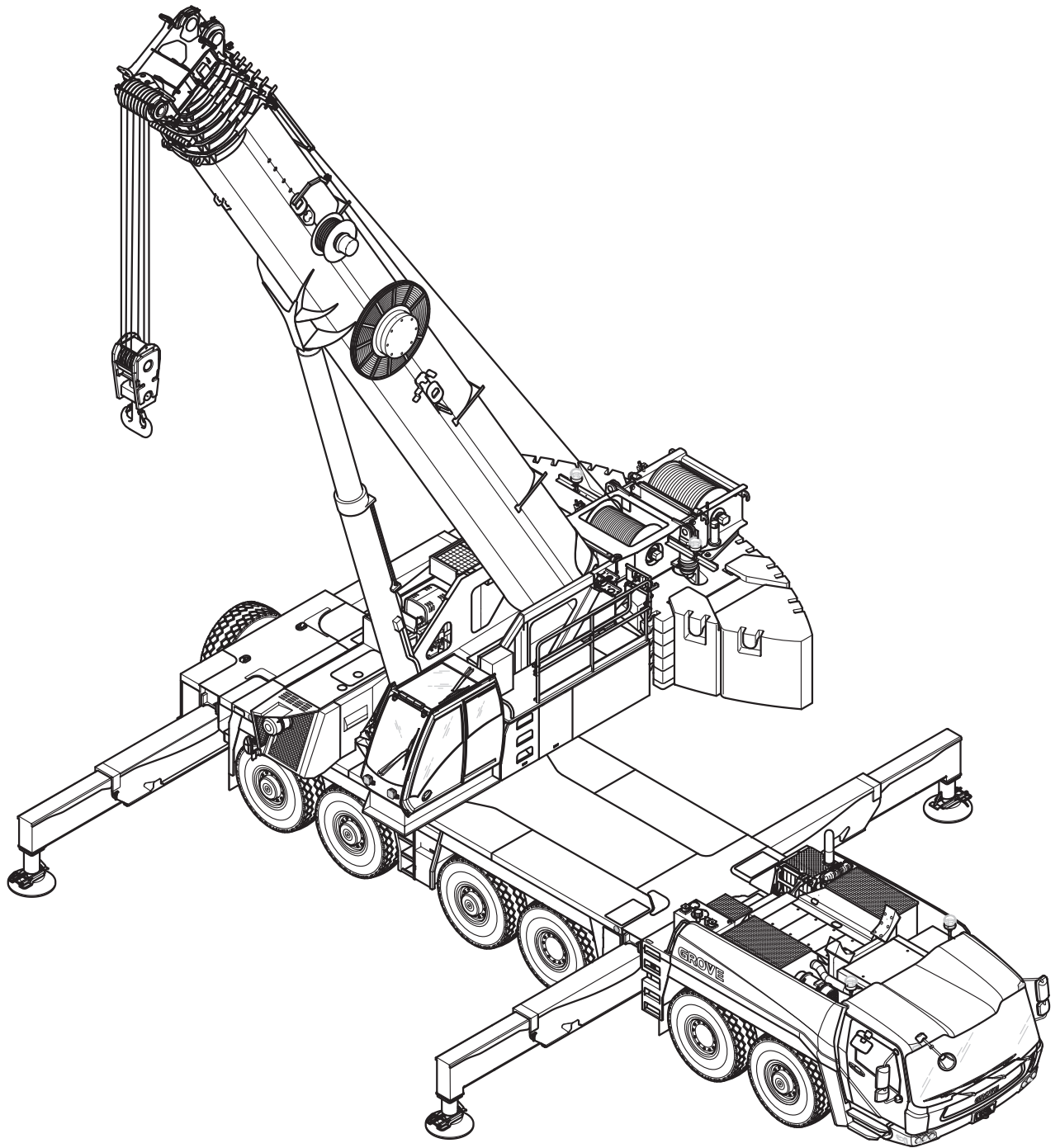

3 302 596 en

05.04.2017

Grove

Manitowoc

National Crane

Potain



CLICK HERE TO **DOWNLOAD** THE COMPLETE MANUAL

- Thank you very much for reading the preview of the manual.
- You can download the complete manual from: [www.heydownloads.com](http://www.heydownloads.com) by clicking the link below



- Please note: If there is no response to CLICKING the link, please download this PDF first and then click on it.

CLICK HERE TO **DOWNLOAD** THE COMPLETE MANUAL

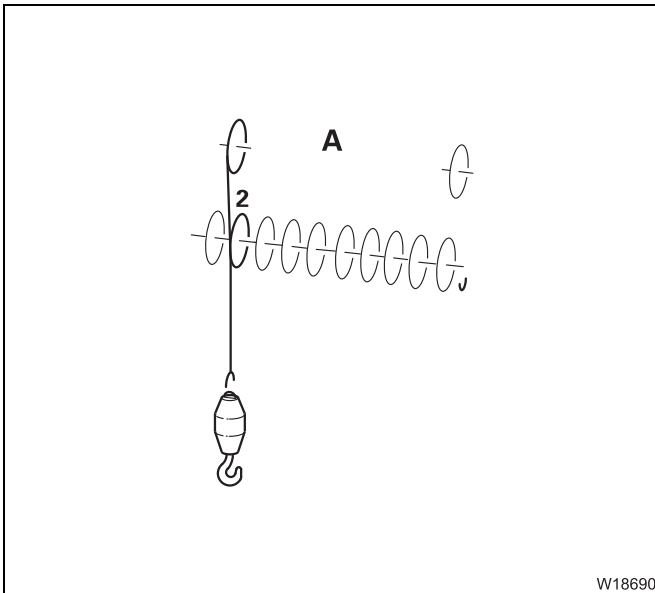

**Hook tackle**

Reeving

**A** 1x

# 1

## Overview

### 1.1

#### Accidents

In the event of an accident, contact the relevant branch office of **Manitowoc Crane Care** in the country in which you are working and specify your crane type and serial number.

Adhere to the requirements regarding the obligation to report accidents prevalent in the country in which you are working and inform the supervisory authorities responsible for that particular type of accident (e.g. material damage, injuries to persons).

### Driver's safety guard

Name	Length x width x height in m	Weight in kg
Rear bumper for versions with ROB <sup>1)</sup>	3.0 x 0.4 x 1.2	120

1) Additional equipment

### Hose drum

Name	Diameter x width in m	Weight in kg
Hose drum, complete with hose	1.55 x 0.4	275

### Hook blocks and hook tackle

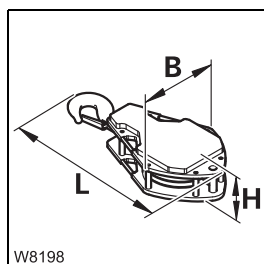

Name	Length x width x height (L) x (W) x (H) in m	Weight In kg
Double hook, 9 sheaves	2.30 x 0.95 x 0.85	3,000
Double hook, 7 sheaves	2.00 x 0.80 x 0.70	1,750
Double hook, 5 sheaves	1.85 x 0.70 x 0.60	1,650
Single hook, 3 sheaves	1.95 x 0.65 x 0.40	1,125
Double hook, 3 sheaves	1.75 x 0.65 x 0.40	1,125
Single hook, 1 sheave	1.50 x 0.65 x 0.35	620
Hook tackle	0.91 x 0.35 x 0.35	300

Lifting capacity of the hook blocks;  *Lifting capacity table*



## 1.6

### Documentation supplied

The precise number of documents supplied depends on the rigging mode of the truck crane. The following documents are included in delivery:

– **Operating Manual**

Contains information on driving and crane operation.

– **Lattice extension operating manual**

Is only supplied when the truck crane is equipped with a lattice extension or other parts for extending the main boom (e.g. auxiliary single-sheave boom top and heavy load lattice extension).

– **Operating manual for additional equipment**

This is only supplied when the truck crane is supplied with additional equipment which is not described in the operating manual for driving and crane operation.

– **Documents from other manufacturers**

Original documentation for parts not manufactured by **Manitowoc Crane Group Germany GmbH**, such as the engine and central lubrication system, as well as the tachograph, auxiliary heaters, radio and, where appropriate, other additional equipment.

– **Maintenance manual**

Contains solely information on maintenance work and contains no instructions for repair work.

– **Safety manual**

Provides information on the safe operation of the truck crane.

– **Circuit diagrams**

Circuit diagrams for the electrical systems, hydraulic systems and pneumatic systems are supplied.

– **Lifting capacity table**

Information on the lifting capacity when the truck crane is in different rigging modes.



**1.8****Conversion table for US measuring units**

The following conversion factors will help you convert from metric to US units when the truck crane is used in countries that use US units of measurement and vice versa.

<b>Converting from</b>	<b>into</b>	<b>Multiply by</b>
mm	into	0.03937
into	mm	25.4
m	ft	3.28084
ft	m	0.30479
m <sup>2</sup>	ft <sup>2</sup>	10.76391
cm <sup>2</sup>	in <sup>2</sup>	0.155
cm <sup>3</sup>	in <sup>3</sup>	0.061
l	gal (US)	0.264178
kg	lbs	2.204622
lbs	kg	0.45359
t	lbs	2,204.622
lbs	t	0.0004536
kN	lbf	224.809
daN/cm <sup>2</sup>	lbf/in <sup>2</sup>	14.50378
lbf/in <sup>2</sup>	daN/cm <sup>2</sup>	0.06895
bar	psi	14.50378
psi	bar	0.06895
m/s	ft/s	3.28084
km/h or km	mph or mi	0.62137
mph or mi	km/h or km	1.60935
Nm	lbf ft	0.7375
°C	°F	1.8 x °C+32
°F	°C	(°F-32)/1.8
t/m <sup>2</sup>	lbs/ft <sup>2</sup>	204.8
m <sup>2</sup> /t	ft <sup>2</sup> /lbs	0.04882

## 2.2

### Organisational measures

The operating manual and the lifting capacity table should be kept in the truck crane for immediate access at all times, and must not be removed from the truck crane. You must have read and understood the operation and safety instructions in this operating manual and comply with them when working.

In addition to the operating manual and the lifting capacity table, observe all general, statutory and otherwise applicable regulations concerning accident prevention and environmental protection. You must have read and understood these and observe them when operating the crane and driving.

They could include:

- How to deal with hazardous materials,
- The wearing of personal protective equipment,
- Road traffic regulations and
- All applicable requirements concerning the operation of a crane.

Make sure that persons who will work on the truck crane are provided with the required information prior to starting operations. Instruct your personnel (e.g. banksmen, slingers, rigging personnel) accordingly.

Make sure the maintenance personnel have the necessary expertise for safe crane operation. Make sure the maintenance personnel have access to the operating manual.

Only qualified or trained personnel may carry out work on the truck crane. Responsibilities regarding the operation of the crane, rigging, maintenance and repair work must be clearly defined.

Make sure only authorised personnel carry out work on the truck crane.



## 2.6

### Instructions on transporting persons

The truck crane is intended for lifting loads. Transporting persons is considered improper use of the truck crane.

It is prohibited to:

- Transport persons in any way with the lifting tackle or on the load.
- Transport persons outside the driver's cab.
- Transport persons on the lattice extensions or boom extensions.
- Use the truck crane for any kind of sport or recreation event, especially for “bungee” jumping.
- Directly attach equipment for lifting persons on a luffing jib.
- Transport persons with the truck crane when another, less dangerous method of transporting persons is possible.

In addition to the provisions of in this section, always also observe the legal requirements and guidelines for transporting persons applicable in the country in which you are working.

Further information on transporting persons can be found under the address: <http://fem-eur.com>.

#### Equipment for lifting persons

When lifting persons, only use equipment for lifting persons that comply with the requirements specified in the standards and regulations applicable in the country in which you are working.

The equipment for lifting persons must be fastened and secured as prescribed.

The prescribed personal protection equipment must be available and used (safety harnesses, etc.).



<b>15</b>	<b>Outriggers:</b>	
	– Outrigger control units	▣▣▣▣ p. 9 - 52
	– Control units for raising the axles	▣▣▣▣ p. 9 - 52
	– Emergency stop switch	▣▣▣▣ p. 4 - 24
<b>16</b>	<b>Urea tank<sup>1)</sup></b>	▣▣▣▣ p. 4 - 8
<b>17</b>	<b>Connection for battery charger<sup>1)</sup></b>	▣▣▣▣ p. 7 - 11
<b>18</b>	<b>Battery master switch</b>	▣▣▣▣ p. 4 - 10
<b>19</b>	<b>– Filler connection for the compressed air system</b>	▣▣▣▣ p. 7 - 6
	<b>– Tyre inflater connection</b>	▣▣▣▣ p. 7 - 17
<b>20</b>	<b>Adjusting the mirrors</b>	▣▣▣▣ p. 5 - 8
<b>21</b>	<b>– Switching off the boom floating position<sup>1)</sup></b>	▣▣▣▣ p. 12 - 17
	<b>– Switching on the boom floating position<sup>1)</sup></b>	▣▣▣▣ p. 6 - 13
	<b>– Switching off boom pre-tensioning<sup>1)</sup></b>	▣▣▣▣ p. 12 - 19
	<b>– Switching on boom pre-tensioning<sup>1)</sup></b>	▣▣▣▣ p. 6 - 14
<b>22</b>	<b>Valves on carrier hydraulic tank</b>	▣▣▣▣ p. 4 - 10
<b>23</b>	<b>Hydraulic oil cooler, second cooler<sup>1)</sup></b>	
<b>24</b>	<b>Engine for driving</b>	▣▣▣▣ p. 4 - 1
<b>25</b>	<b>Air intake inhibitor<sup>1)</sup></b>	▣▣▣▣ p. 4 - 25
<b>26</b>	<b>Warning plates for vehicle width<sup>1)</sup></b>	▣▣▣▣ p. 5 - 9
<b>27</b>	<b>Fixed ladders</b>	▣▣▣▣ p. 4 - 4
<b>28</b>	<b>Control unit<sup>1)</sup></b>	▣▣▣▣ p. 3 - 33
	– Rear supporting box lock	
	– Auxiliary supports	
<b>29</b>	<b>Reverse camera<sup>1)</sup></b>	▣▣▣▣ p. 3 - 51
	<b>Spotlights on rear of carrier on/off<sup>1)</sup></b>	▣▣▣▣ p. 3 - 63

<sup>1)</sup> Additional equipment

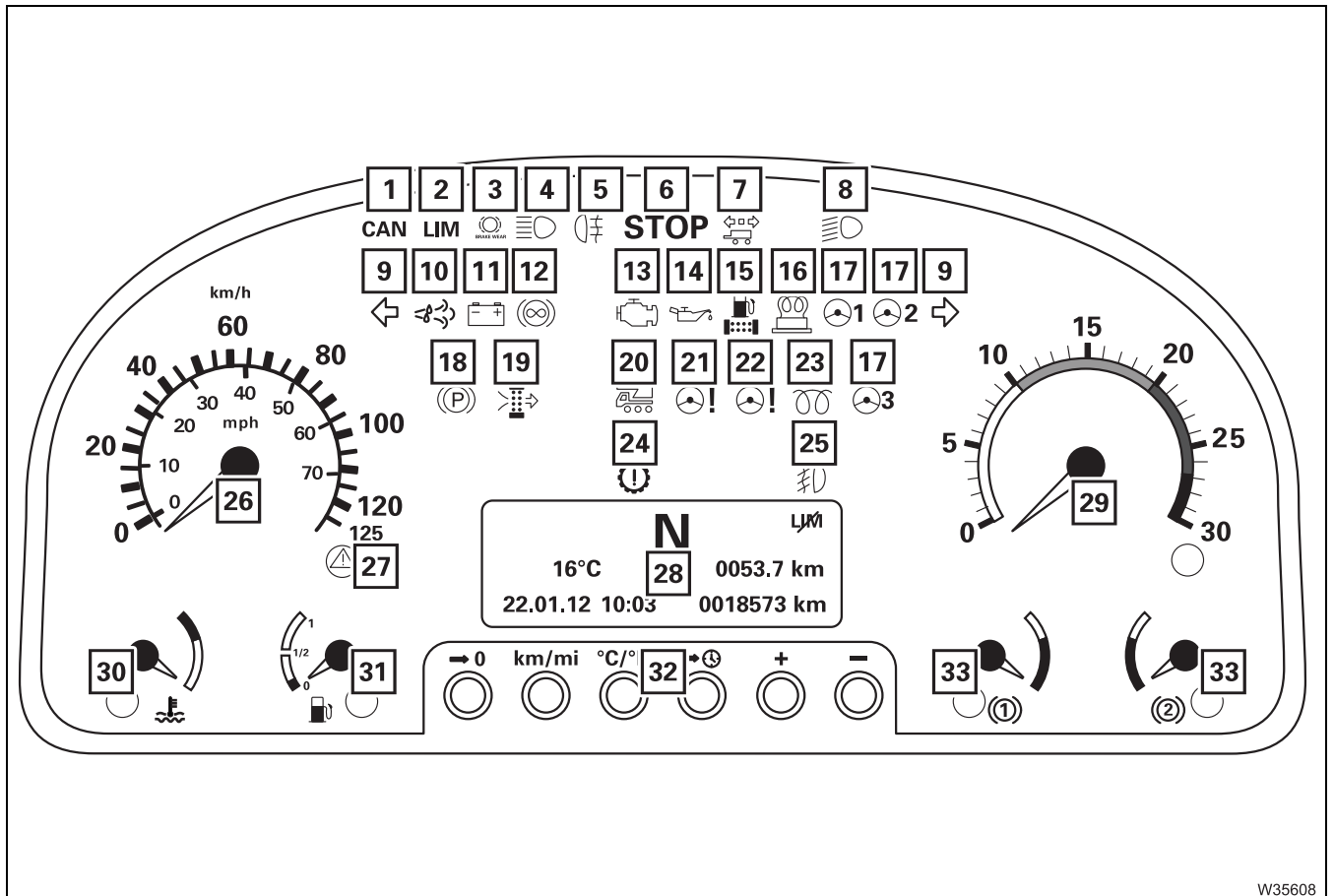

W35608

- |           |  |             |
|-----------|--|-------------|
| <b>24</b> | Transmission malfunction                     |             |
| <b>25</b> | Fog light indicator lamp <sup>1)</sup>       | ▣ p. 3 - 60 |
| <b>26</b> | Speedometer                                  | ▣ p. 3 - 67 |
| <b>27</b> | Tachograph malfunction warning <sup>1)</sup> | ▣ p. 5 - 19 |
| <b>28</b> | Display, driving mode                        | ▣ p. 3 - 16 |
| <b>29</b> | Tachometer                                   | ▣ p. 3 - 39 |
| <b>30</b> | Coolant temperature display                  | ▣ p. 4 - 20 |
| <b>31</b> | Fuel level display                           | ▣ p. 4 - 20 |
| <b>32</b> | Keypad for driving display                   | ▣ p. 3 - 16 |
| <b>33</b> | Display – supply pressure in brake circuits  | ▣ p. 3 - 54 |

<sup>1)</sup> Additional equipment

<b>1</b> Switch measuring range	▣▣▣▣▶ p. 3 - 65
<b>2</b> Current inclination display	▣▣▣▣▶ p. 3 - 65
<b>3</b> Overall level pre-selection	▣▣▣▣▶ p. 3 - 64
<b>4</b> Front level pre-selection	▣▣▣▣▶ p. 3 - 64
<b>5</b> Right level pre-selection	▣▣▣▣▶ p. 3 - 64
<b>6</b> Rear level pre-selection	▣▣▣▣▶ p. 3 - 64
<b>7</b> Left level pre-selection	▣▣▣▣▶ p. 3 - 64
<b>8</b> Setting the on-road level	▣▣▣▣▶ p. 3 - 65
<b>9</b> Vehicle level display	▣▣▣▣▶ p. 3 - 65
<b>10</b> Suspension display	▣▣▣▣▶ p. 3 - 59
Suspension on/off	▣▣▣▣▶ p. 3 - 59
<b>11</b> Lowering/raising the level	▣▣▣▣▶ p. 3 - 64
<b>12</b> Lowering/raising the level	▣▣▣▣▶ p. 3 - 64
<b>13</b> Suspension operation pressure gauge	▣▣▣▣▶ p. 3 - 59
<b>14</b> Left axle pressure preselection <sup>1)</sup>	▣▣▣▣▶ p. 3 - 66
<b>15</b> Right axle pressure preselection <sup>1)</sup>	▣▣▣▣▶ p. 3 - 66

<sup>1)</sup> Additional equipment



## 3.2

## Short description of the operating elements



### Risk of accident by operator error!

This section is not a complete operating manual. It only provides a general overview of the functionality of the operating elements.

Before using the operating elements for the first time, read through the following chapters and the safety instructions listed there.



This section does not contain all the requirements that must be fulfilled for several operating elements to be active.

If some operating elements do not work, first read the following chapters which are referred to at the respective places before contacting **Manitowoc Crane Care**.

### 3.2.1

### Definition of direction information

#### Basic rule

Direction information always depends on whether the carrier or the superstructure is being operated.

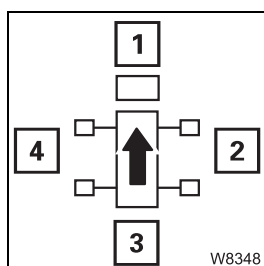

#### On the carrier

The driver's cab is always at the front, which means that:

- |          |          |
|----------|----------|
| 1: front | 2: right |
| 3: rear  | 4: left  |

**Forwards** always means with driver's cab leading.

**Backwards** always means the rear lights on the carrier are to the front.

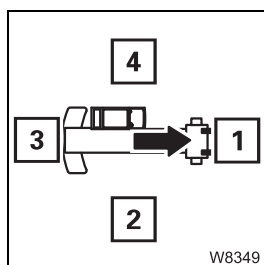

#### On the superstructure

The main boom head is always at the front, which means that:

- |          |          |
|----------|----------|
| 1: front | 2: right |
| 3: rear  | 4: left  |



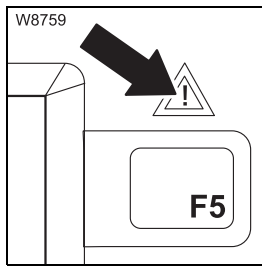

### Error/warning message

- **Flashing:** New warning message or error has occurred
- **On:** Error acknowledged – but still present
- **Off:** No warning message or error present

➡ p. 11 - 114

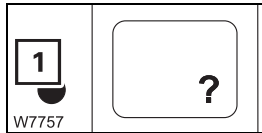

### Opening the Error submenu

The lamp (1) lights up or flashes.

- **To open:** Press button once – submenu opens

➡ p. 11 - 114

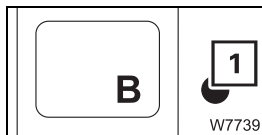

### Opening the Warning submenu

The lamp (1) lights up or flashes.

- **To open:** Press button once – submenu opens

➡ p. 5 - 48



### Exiting the submenu/input mode

The lamp (1) lights up.

- **Press the button once:**
  - The opened submenu closes – the menu from the next higher level is opened
  - Input mode is deactivated



### Input confirmation

The lamp (1) lights up.

- **Press the button once:** A newly entered value is saved

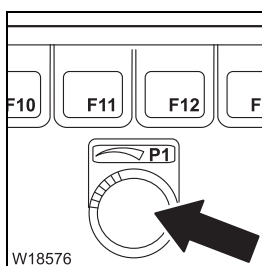

### Entering values

Input mode is switched on.

- **To the right:** Increases the value
  - **To the left:** Decreases the value
- Slow turning changes the value slowly  
Fast turning changes the value fast





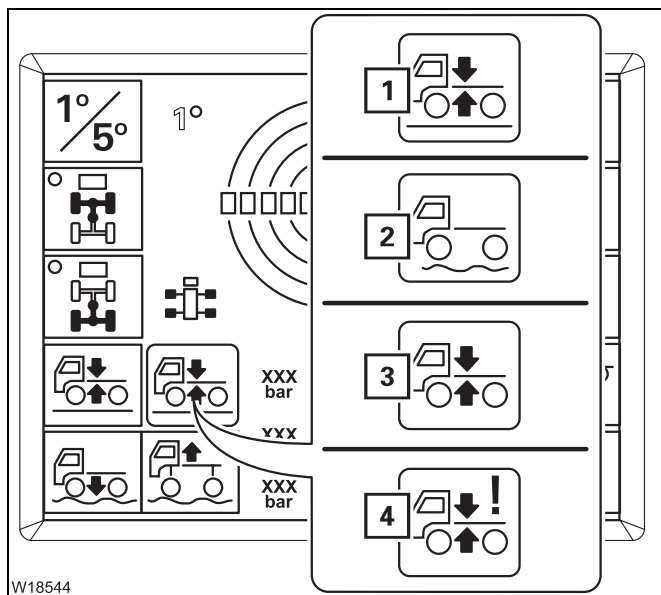

### Vehicle level display

The current status is shown using different symbols:

- 1 Green – on-road level
- 2 White – no on-road driving level
- 3 Yellow – level change
- 4 Violet – error

➡ p. 5 - 64

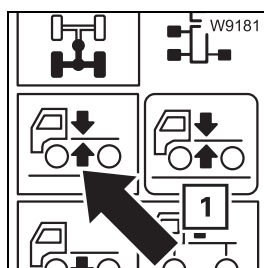

### Setting the on-road level

– To set the on-road level:

Press the button until the symbol (1) is green

➡ p. 5 - 65

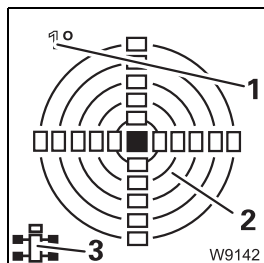

### Current inclination display

- 1 Measuring range display
- 2 Inclination indicator
- 3 Directional indicator

➡ p. 5 - 66

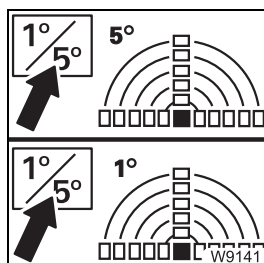

### Switch measuring range

– To switch over: Press button once – the current measuring range 1° or 5° is shown

➡ p. 5 - 66



# 4

## Starting the engine for driving / switching it off

### 4.1

### Starting the engine from the driver's cab

This section describes how to start the engine from within the driver's cab. You can also start the engine from the crane cab;  *Starting the engine for driving for rigging work*, p. 12 - 23.

#### 4.1.1

#### CHECKLIST: Starting the engine



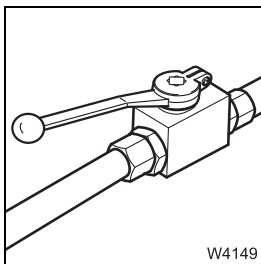

This checklist is not a complete operating manual. There are accompanying instructions, which are indicated by cross-references.

**Observe the warnings and safety instructions there!**

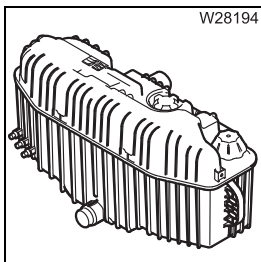

1. Check that the valves on the hydraulic tank are open;  p. 4 - 10.



2. Check the coolant level of the engine;  *Maintenance Manual*.

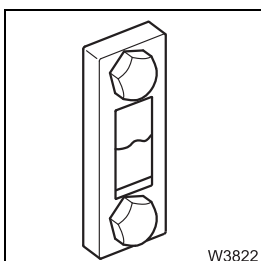

3. Check the oil level in the hydraulic system;  *Maintenance Manual*.



### Checking the hand-held control

Check that the hand-held control has been removed, and that bridging plugs for the hand-held control are inserted into all sockets;  p. 10 - 8.

## 4.1.6

### Switch on the ignition



The ignition can only be switched on if the bridging plugs have been inserted in all sockets for the hand-held control;  *Hand-held control*, p. 9 - 114.

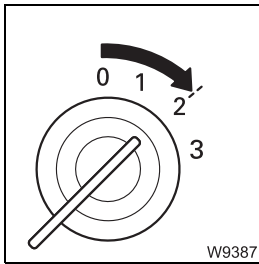

- Insert the ignition key into the ignition lock and turn the key to position **2**.

After switching on the ignition, a lamp test is performed and switching states are aligned.

## 4.1.12

### Monitoring submenu

The *Monitoring* submenu provides an overview of the most important measured values.

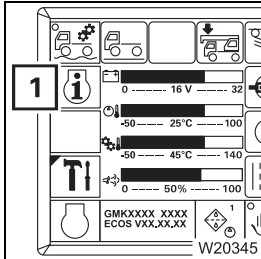

- If necessary, open the main menu  and press the button (1) once.

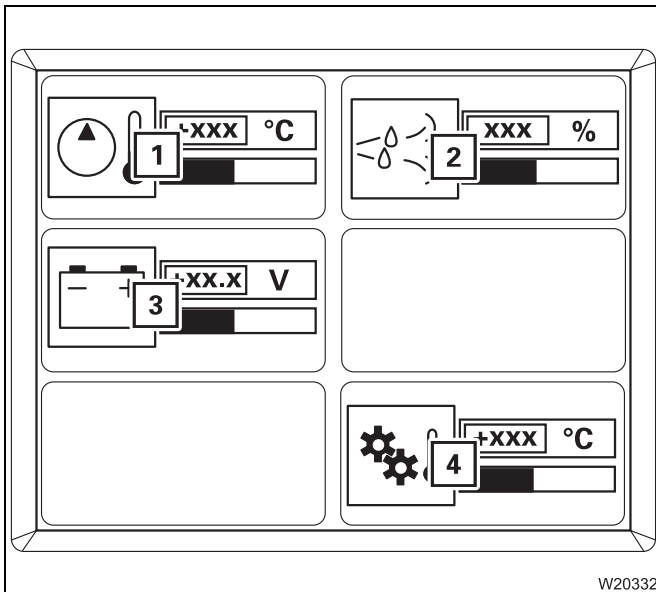

This opens the *Monitoring* submenu.

The following values are displayed:

- 1 The hydraulic oil temperature in °C
- 2 Carbamide supply in percent
- 3 Voltage in volts
- 4 The transmission oil temperature in °C

The colour of the bar below the values indicates the area in which the value can be found.

**Green:** Value OK.

**Yellow:** Limit value almost reached

**Red:** Limit value exceeded (or not reached) – warning message;  
 p. 5 - 48.

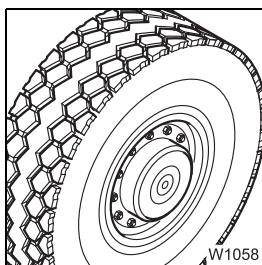

**8. Check the tyres:**

- Tyre pressure when tyres are cold in on-road mode; ■■■► p. 1 - 14.
- Other checks; ■■■► *Maintenance Manual*.

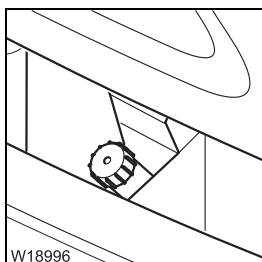

**9. Windscreen washing system – check level; ■■■► p. 5 - 7.**

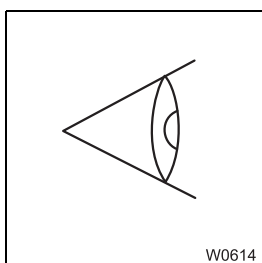

**10. Carry out an inspection of the truck crane, looking out in particular for any leaking fluids (oil, fuel or water).**

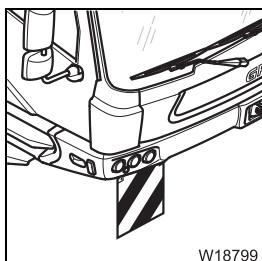

**11. The warning signs for marking the vehicle width are folded down (only for vehicle widths over 2.75 m );  
Vehicle width; ■■■► p. 1 - 8,  
Warning signs; ■■■► p. 5 - 7.**

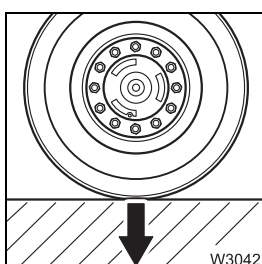

**12. The detachable equipment parts must be stripped down so that they fulfil the regulations of the country in which you are working as regards permissible weights and axle loads, lengths, widths, height, etc.  
For a driving mode with a maximum axle load of 12 t; ■■■► *Driving modes*, p. 6 - 1.**



### 5.1.3

## Adjusting the seats and steering column

### Driver's seat

The seat height and lumbar support (version 1) are adjusted pneumatically. You can only make these adjustments when:

- Sufficient air pressure is available in the secondary consumer circuit. You may have to build supply pressure;  p. 5 - 10.
- The switch (1) on the driver's seat is off (not pressed in),
- Sit on the driver's seat; the seat will rise to the last position set.

You can make various settings as required.

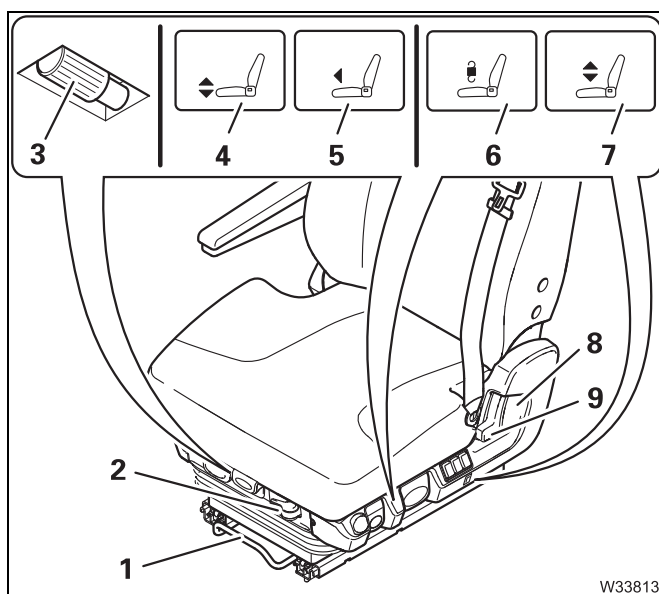
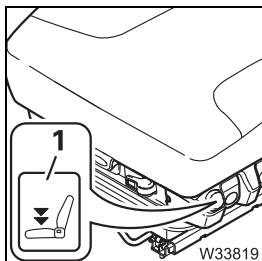

### Version 1

- 1 Seat – longitudinal adjustment
- 2 Vertical cushioning on/off
- 3 Armrests – inclination<sup>1)</sup>
- 4 Seat cushion – angle
- 5 Seat cushion – longitudinal adjustment
- 6 Adjust suspension stiffness to body weight
- 7 Seat – height
- 8 Back rest – angle
- 9 Shoulder supports

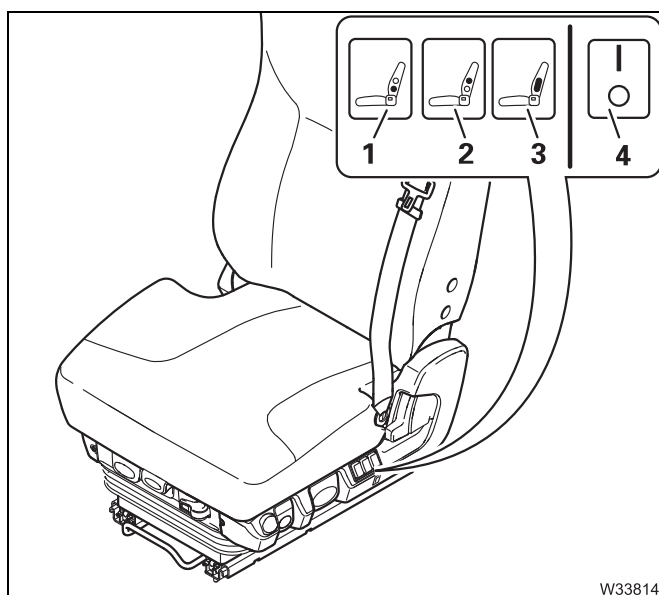

- 1 Lower lumbar support area
  - 2 Upper lumbar support area
  - 3 Lateral support
  - 4 Seat heating on/off<sup>1)</sup>
- <sup>1)</sup> Additional equipment

The settings are made pneumatically. The following applies to all buttons:

- Empty the air cushion:** Push down  
**Fill the air cushion:** Push up



The different time groups are shown with the following symbols:

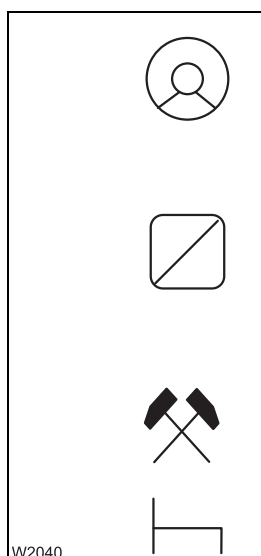

**Driving times:** As soon as the vehicle starts to move, the tachograph automatically switches to the symbol for driver 1 driving time. If there are two diagram sheets inserted, the tachograph automatically switches to stand-by time for two-drivers operation.

**Working hours:** For all other work, the same activities apply as for stand-by time. When setting the working hours and stand-by time, observe the applicable local regulations for the country in which you are working.

**Stand-by time:** Periods of presence at the truck crane, e.g. crane operation, maintenance work, passenger time, etc.

**Breaks and periods of rest:** These times are prescribed by law and must be observed.



If the drivers swap during **two-driver operation**, the diagram sheets in the trip recorder also have to be changed. The driving time is always recorded on the diagram sheet which is on the isolating plate (driver 1).



The symbol for resting time has to be entered for driver 2 in **single-driver operation**. Otherwise an error message will appear.

## 5.2.7

### Driving and changing gears

While driving, the transmission changes to the gear suitable for the current load, engine speed and position of the accelerator.



When the gear oil temperature falls below approx.  $-7\text{ }^{\circ}\text{C}$ , only gears 1 and 2 are used in gear position **D**.

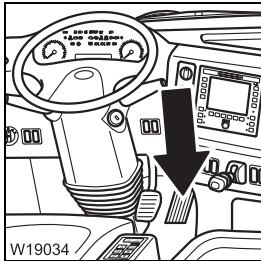

#### Automatic upshifting

You can influence upshifting by using the accelerator.

- Pressing the accelerator Upshifting at low engine speed slightly:
- Pressing the accelerator Upshifting at high engine speed harder:

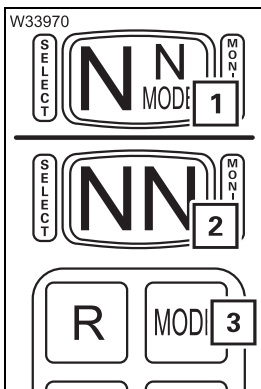

You can influence upshifting by using the driving mode – button **(3)**.

- 1 Driving mode **P** on: Upshifting at high engine speed
- 2 Driving mode **E** on: Upshifting at low engine speed

#### Automatic downshifting

- When you slow down the truck crane by braking, the transmission shifts down when the appropriate engine speed is reached.
- If you fully depress the accelerator full (kick down), the transmission first shifts to a lower gear. After that, it will shift to a higher gear only once a higher engine speed has been reached, so as to achieve maximum acceleration.



## Switching off

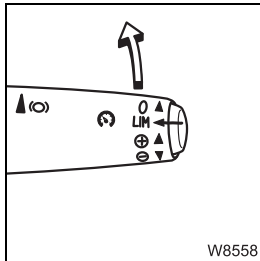

- Push the switch forwards once. The cruise control is now switched off.
- Cruise control is also switched off,
- when the service brake or additional brake is applied,
  - when speed falls below 10 km/h,
  - when the Temposet function is switched on,
  - when the ignition is switched off.

### 5.3.3

## Temposet

You can use Temposet to limit the maximum speed.

## Switching on

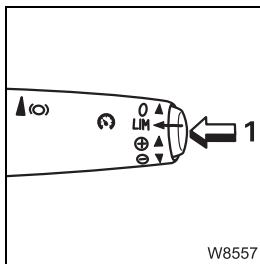

- Press the button (1) once.

Temposet is now switched on. The current speed is taken as the maximum speed.

You can exceed the speed by pressing the accelerator as far down as it will go (kick-down). The Temposet limits the speed again only once you release the accelerator and press it again.

## Switching off

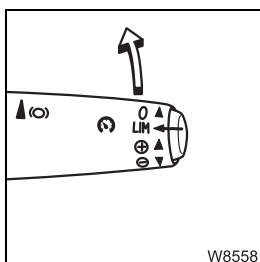

- Press the switch forwards twice.
- The Temposet is now switched off.

### 5.3.8

## Override torque reduction

When the carbamide supply is empty, the torque reduction is activated via the engine control system.

You can override torque reduction up to 3 times.

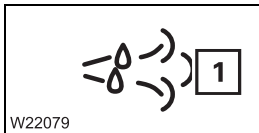

– If the carbamide level drops to the reserve level, the lamp (1) lights up.

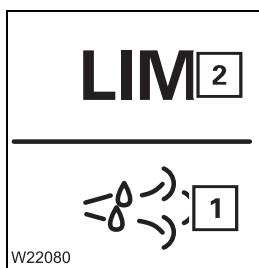

– If the carbamide supply is used up, the lights (1) and (2) will light up.



– If lamp (1) flashes, the engine torque is reduced the next time the engine is started.

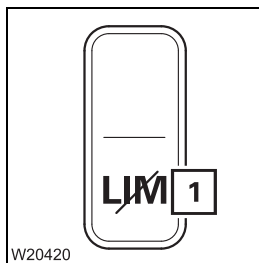

The engine torque is reduced.

- Press button (1) down to override torque reduction.

You can override torque reduction up to 3 times.

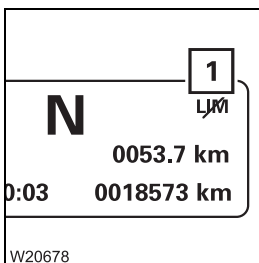

The symbol (1) is displayed.

- Refill with carbamide immediately; ➔ *Carbamide*, p. 4 - 8.

After the next engine start the torque reduction is deactivated.

The symbol (1) disappears.

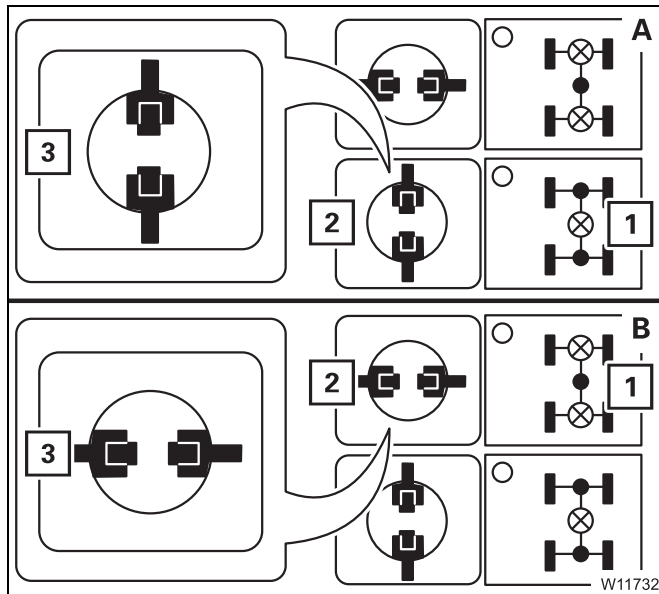

### Switching off

- Press button (1) once for:
  - Central differential locks (A) or
  - Transverse differential locks (B),The dot turns **black**.

### Display:

- The symbol (3) first turns yellow,
- Then symbol (2) turns **green**, differential locks off.

If symbol (2) is not displayed, then drive back and forth slowly.

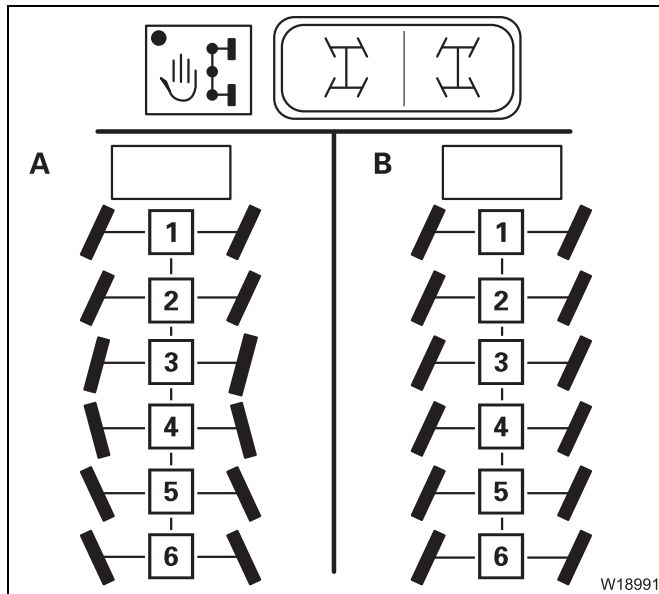

**(A) – For driving around corners**

- Steer the 6th axle line in the opposite direction to the 1st to 2nd axle line.

The other axle lines are steered to suit the turning radius.

**(B) – For crab travel mode**

- Steer the 6th axle line in the same direction as the 1st to 2nd axle line.

The other axle lines are always steered in the same direction.

**Automatic**

- Steer the 1st to 2nd axle line with the steering wheel.

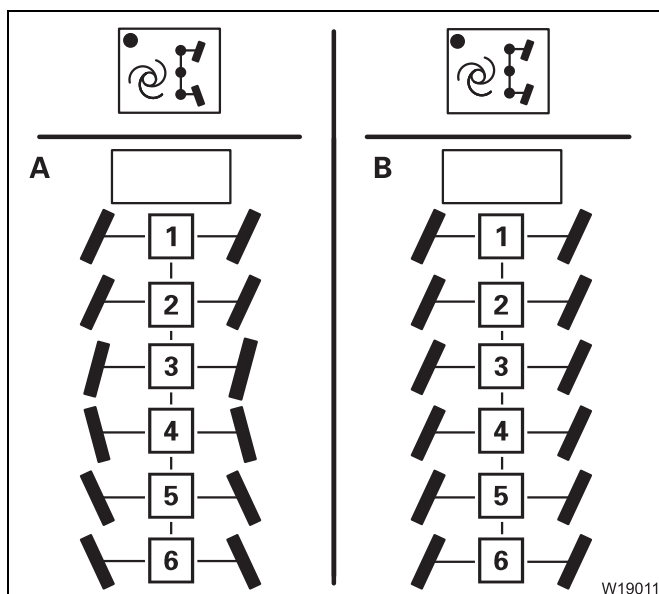

**(A) – when driving around corners**

The further axle lines are steered out in line with the turning radius, and with or against the steering angle on the 1st to 2nd axle line.

**(B) – for crab travel mode**

The further axle lines are steered in the same direction as the 1st to 2nd axle lines.



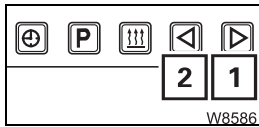

- Set the current time on the flashing display – button (1) or (2), e.g. 14:00.



- Wait for 5 seconds. The new time is saved and then the weekday flashes, e.g. **MO** for Monday.

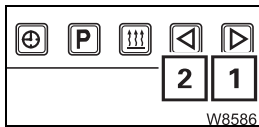

- Set the current day of the week on the flashing display.

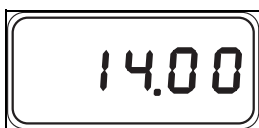

After 5 seconds, the display stops flashing and the current time is displayed. The weekday goes out.

The time and weekday have now been set.

### Saving automatic heating start

Heating is started automatically on schedule only if the time and the day of the week have been correctly set; p. 5 - 82.

You can set three different automatic heating starts – up to seven days in advance.



If you call up values in order to change them during the following setting process, they flash for 5 seconds. The entry must be made within this period. The value stops flashing after 5 seconds and is saved as the new value.

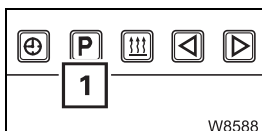

- To retrieve a storage location, press the button (1) once.



The following flash:

- The retrieved storage location, e. g. 2
- The last saved heating start, e.g. 06:00.

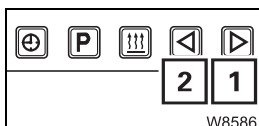

- Set the time for the desired heating start – button (1) or (2), e.g. 08:00.



## 6 Driving modes

<b>6.1</b>	<b>Driving modes</b> .....	6 - 1
6.1.1	Information on how to use the tables .....	6 - 2
6.1.2	Tables for a maximum axle load of 12 t .....	6 - 3
6.1.3	Maximum permitted speeds with an axle load of over 12 t .....	6 - 6
<b>6.2</b>	<b>Weighing the truck crane</b> .....	6 - 7
<b>6.3</b>	<b>Rigging work for driving with a trailer</b> .....	6 - 11
6.3.1	Switching on the slewing gear freewheel .....	6 - 12
6.3.2	Switching on the boom floating position .....	6 - 13
6.3.3	Switching on boom pre-tensioning .....	6 - 14
6.3.4	Adjusting axle pressure .....	6 - 15
6.3.5	Switching the superstructure driving lights on/off .....	6 - 17
<b>6.4</b>	<b>Main boom, removing/installing</b> .....	6 - 19
6.4.1	CHECKLIST: Removing the main boom .....	6 - 20
6.4.2	CHECKLIST: Mounting the main boom .....	6 - 23
6.4.3	Slinging the main boom .....	6 - 26
6.4.4	Removing/attaching the clamps .....	6 - 28
6.4.5	Switching the pressure relief on/off .....	6 - 29
6.4.6	Connecting/disconnecting the derricking cylinder from the boom .....	6 - 30
6.4.7	Extending/retracting the boom pivot pin .....	6 - 33
6.4.8	Disconnecting/connecting hydraulics/electrical .....	6 - 36
6.4.9	Lifting the main boom off/on the turntable .....	6 - 38
6.4.10	Aligning the connecting points .....	6 - 40
6.4.11	Securing/releasing the derricking cylinder .....	6 - 40
6.4.12	Transporting the main boom .....	6 - 41
6.4.13	Inspections after main boom mounting .....	6 - 42
6.4.14	Installing/removing the hose drum .....	6 - 43
<b>6.5</b>	<b>Installing/removing outrigger beams</b> .....	6 - 47
6.5.1	CHECKLIST: Removing the outrigger beams .....	6 - 48
6.5.2	CHECKLIST: Installing the outrigger beams .....	6 - 50
6.5.3	Preparing the truck crane .....	6 - 52
6.5.4	Removing/attaching outrigger pads .....	6 - 53
6.5.5	Disconnecting/establishing the hydraulic connection .....	6 - 55
6.5.6	Disconnecting/establishing the electrical connection .....	6 - 56
6.5.7	Unscrewing/screwing in the spacers .....	6 - 57
6.5.8	Disconnecting/establishing the connections to the supporting box .....	6 - 59
6.5.9	Extending/retracting the outrigger beam .....	6 - 59
6.5.10	Transporting the outrigger beams .....	6 - 63



## Weighing procedure

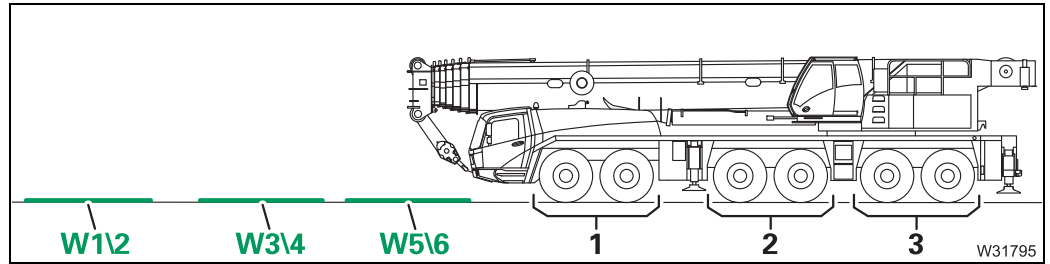

**Perform the weighing procedure only with the crane truck standing on solid and horizontal ground! All scales must be at the same height!**

- Position the scales **W1** to **W6** (or the necessary support plate) directly in front of the truck crane, so that the distances between the scales are exactly the same as the distances between the axle groups **1** to **3**.

In the next step, drive steadily at a very low speed without any steering movements, and brake only very gently.

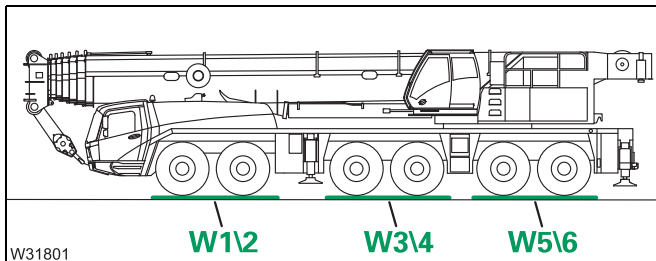

- Drive the truck crane on to the scales **W1** to **W6** (or on to the necessary support plate), so that the axle groups stand centrally on the scales.
- Do **not** apply the parking brake.

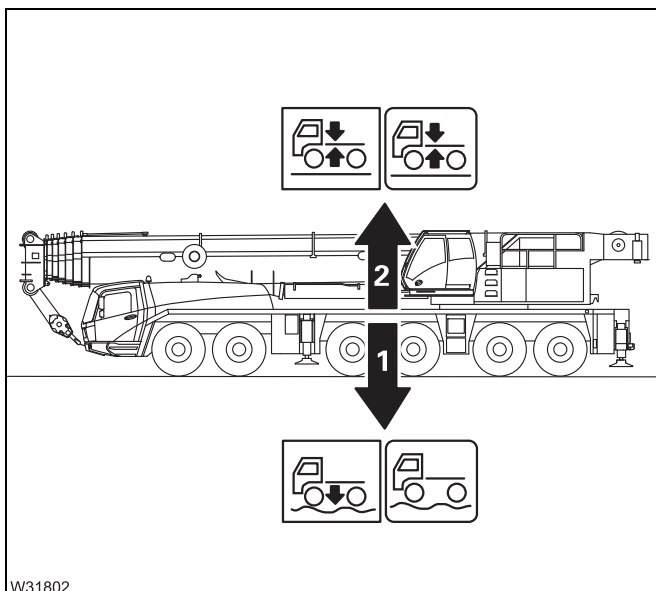

- If the truck crane has to be braked while changing the level, only use the service brake very gently.
- (1) – Use the level adjustment system to lower the truck crane to its lowest position;  p. 5 - 64.
- (2) – Use the **automatic function** to set the level for on-road driving. If you move the axle groups individually the weighing result will be falsified.
- Read the scales and make a note of the results.



## 6.4

### Main boom, removing/installing

This section applies only to truck crane which are fitted with the pulling devices for removing/mounting the main boom.



#### **Risk of accident when removing/installing the main boom without pulling devices!**

Only remove or install the main boom if the truck crane is equipped with the factory-installed pulling devices and with the necessary accessories. Without this factory-installed pulling device, the main boom may only be removed by **Manitowoc Crane Care**.

#### **Additional equipment required**

In addition to the pulling devices, you also need the following accessories:

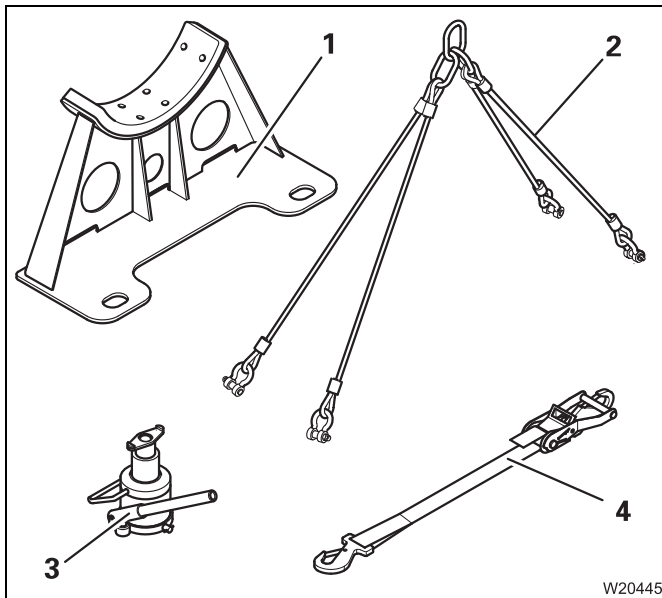

- A derricking cylinder support (1),
  - A tightening belt (4),
  - A lifting device (3),
  - Lifting gear (2),
- as well as
- An auxiliary crane with sufficient lifting capacity,
  - A separate vehicle with sufficient load bearing capacity and loading area.

Transport dimensions and weight;

▣▣▣▣ p. 1 - 10.

## 6.4.5

### Switching the pressure relief on/off

Pressure relief prevents the derricking cylinder from extending when the engine runs, after the main boom has been removed.

#### When removing

- Switch the pressure relief on before pulling the derricking cylinder head axle.

#### When installing

- Only switch off the pressure relief after fitting the derricking cylinder head axle.



#### Risk of accident from falling boom!

Check to see whether the main boom is in the boom rest before switching off the pressure relief.

This prevents the raised main boom from dropping down.

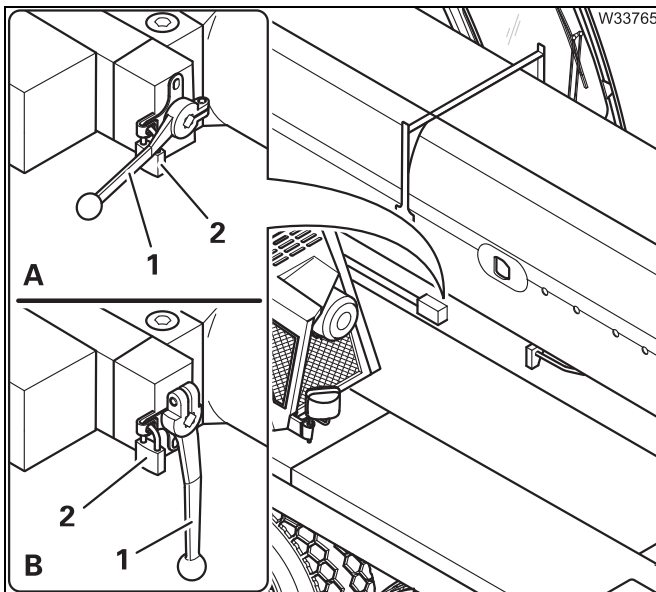

- Remove the padlock (2).
- Bring the lever (1)
  - Used for switching on into position **A**. Depending on its design, the lever will face up or down.
  - To position **B** to switch off.
- Secure the lever with the lock (2) and remove the key.



When the pressure relief is switched on, the main boom cannot be raised.



#### Risk of accident from falling boom!

Never switch on the pressure relief during crane operation.  
This prevents the raised main boom from dropping down.

### Lifting on to the turntable

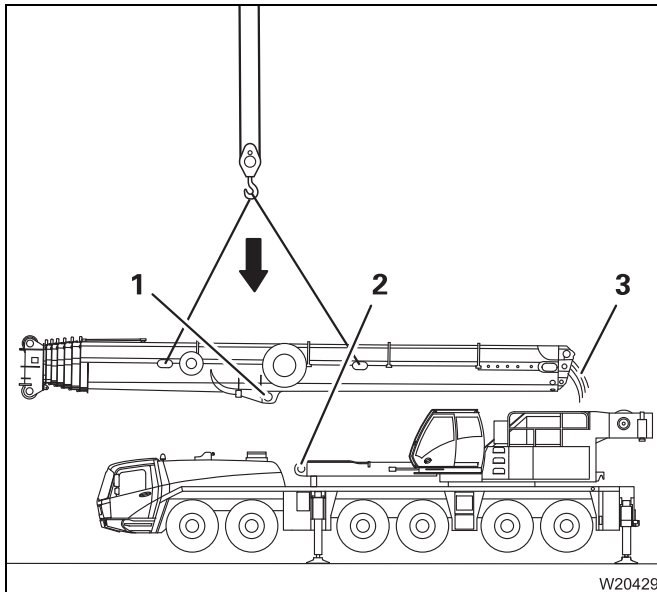

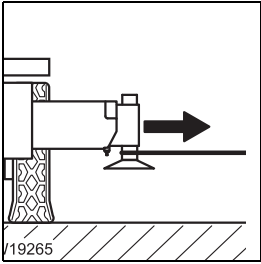

- Lift the main boom backwards and downwards on to the turntable. Make sure that:
  - The connection lines (3) do not hang loose,
  - The pivot point (1) is higher than the driver's cab,
  - The pivot point (1) is located forwards of the derricking cylinder (2),
  - The connecting points are not tilted.

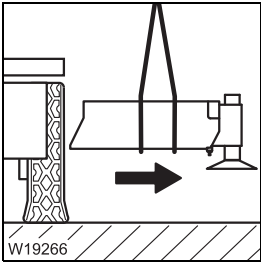

**6.** Sling the outrigger beam and pull it out of the supporting box until it reaches the centre of gravity;  p. 6 - 59.



**7.** – Sling the outrigger beams in the centre of gravity and pull them out of the supporting box.  
 – Lift the outrigger beams onto the separate vehicle.  
 – Attach the connecting elements on the supporting box.  
 *Extending the outrigger beam*, p. 6 - 59  
 *Transporting the outrigger beams*, p. 6 - 63

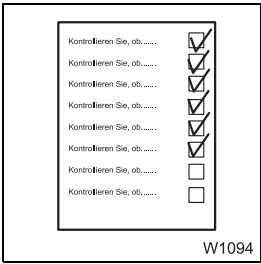

**8.** Remove all necessary outrigger beams in the same way in accordance with this checklist.

**6.5.8**

**Disconnecting/establishing the connections to the supporting box**

The illustrations show as an example the connecting points for the outrigger beam on the front left hand side.

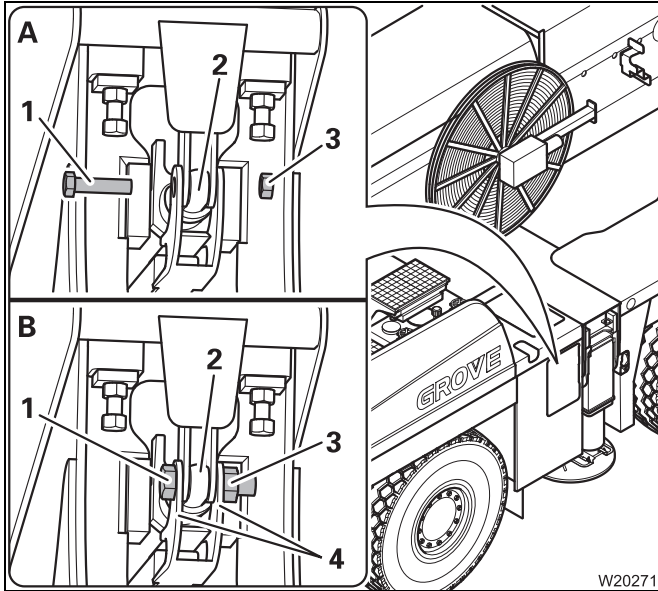

**(A) – To disconnect**

- Undo the wheel nuts (3).
- Remove the bolts (1) from the connecting points (2).

**(B) – Establishing the connection**

- Fasten the bolts (1) with the nuts (3) in the connecting points (2) just tight enough that the attachment plates (4) still have lateral play.

**6.5.9**

**Extending/retracting the outrigger beam**

**Extending the outrigger beam**

- Check that the outrigger beams are released and are secured between each other; *Preparing the truck crane, p. 6 - 52.*



**Risk of damage to hydraulic lines!**

Ensure that the hydraulic lines on the outrigger beam do not remain hanging on the supporting box and become damaged.

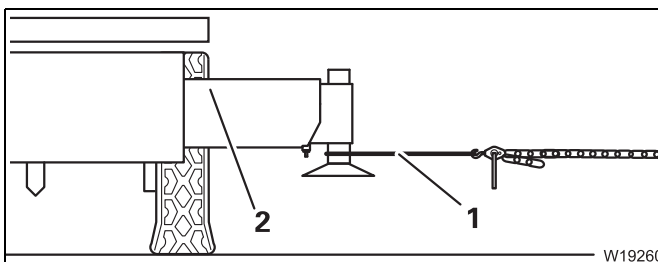

- Fasten the lifting gear (1) and a chain hoist.
- Pull the outrigger beam out so far that the centre of gravity (2) is accessible.



## 6.6.2

### CHECKLIST: Installing the supporting box



This checklist is not a complete operating manual. There are accompanying instructions, which are indicated by cross-references.

**Observe the warnings and safety instructions specified there!**

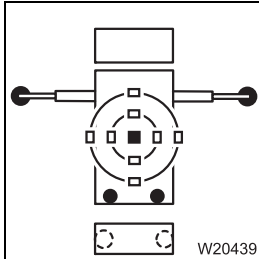

1. Rig the outrigger span 7.98 x 8.50/1.00 m and align the truck crane horizontally; ■■■► p. 6 - 71.

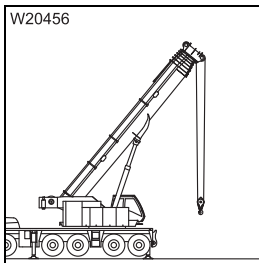

2. With the RCL set accordingly, raise the main boom and slew the superstructure into the position for raising the supporting box; ■■■► *Crane movements during installation and removal*, p. 6 - 81.

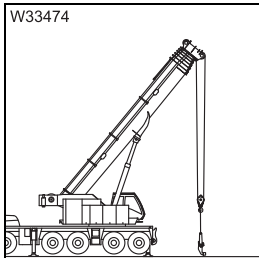

3. Install rear bumper if necessary; ■■■► p. 6 - 86.

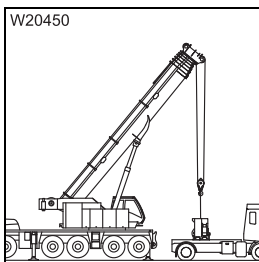

4. Sling the supporting box to the truck crane and remove from the separate vehicle; ■■■► *Slinging points on the supporting box*, p. 6 - 82.

If the supporting box was placed on the supports:  
Retract the supports; ■■■► p. 6 - 79.

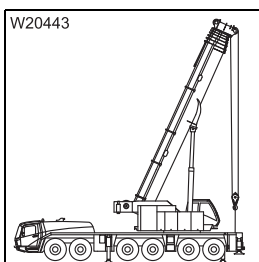

5. Suspend the rear supporting box in the holders on the carrier; ■■■► p. 6 - 77.



## Hanging

The supporting box is within one of the radii permitted by the RCL.

The supports must be retracted before hanging the box.

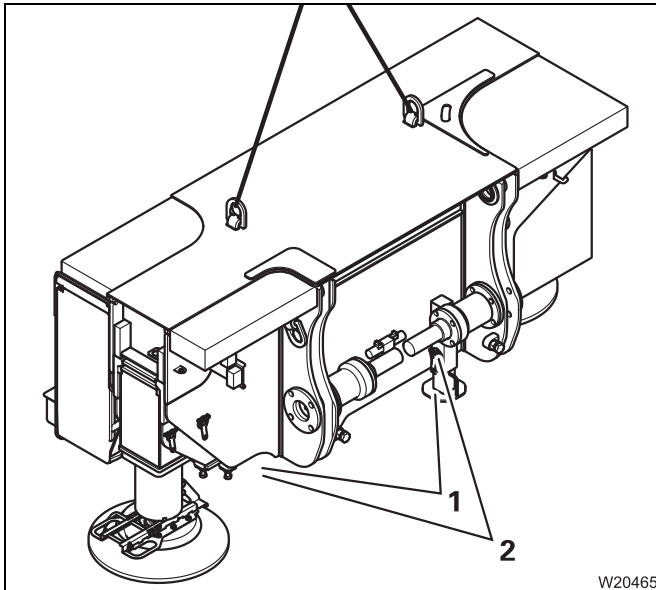

- Sling the supporting box.
- Pull the locking pins (2).
- Retract the supports (1).
- Secure the supports; by inserting the locking pins into the lower hole.
- Where necessary to do so, bring all the outrigger pads into driving position;  p. 12 - 39.

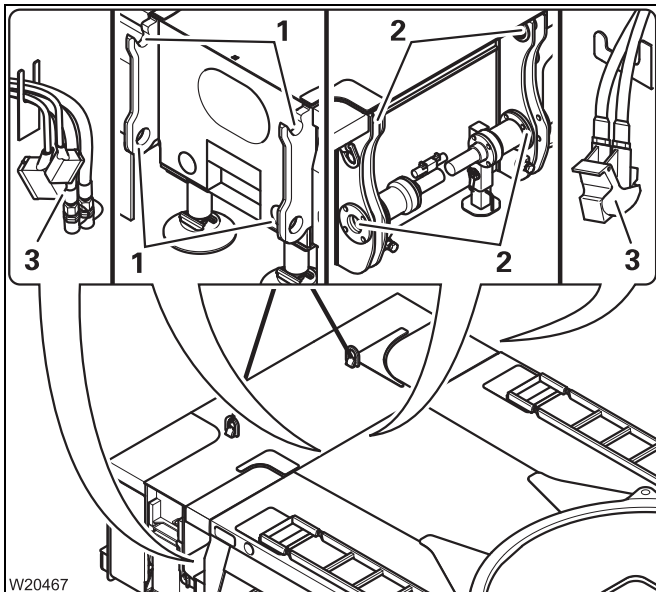

### Do not override the RCL!

- Hoist the supporting box onto the carrier in such a way that the pins (2) on the supporting box are vertically above the mountings (1) on the rear of the vehicle.
- Hang the supporting box in the mountings (1).

Take care that the cables and hoses (3) are not trapped and damaged.

## 6.7

### Rigging the auxiliary hoist

You need the following equipment:

- suitable lifting gear and guide ropes with sufficient load bearing capacity;  
    ▣▣▣▣► *Dimensions and weights of removable parts*, p. 1 - 10,
- a separate vehicle,
- if necessary, a rigging frame for rigging counterweight combinations up to max. 26 t.

#### 6.7.1

### CHECKLIST: Auxiliary hoist, installing

#### Prerequisites

- The truck crane is supported with the required outrigger span as specified in the *Lifting capacity table*; ▣▣▣▣► p. 12 - 30,
- The 54.5 t counterweight combination is resting on the counterweight platform; ▣▣▣▣► p. 12 - 62,  
or
- Install the rigging frame for counterweight combinations of up to a maximum of 26 t ; ▣▣▣▣► p. 6 - 94.

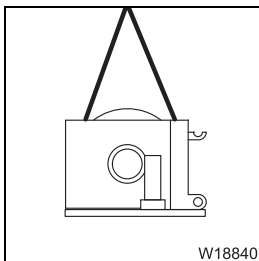

1. Attach the auxiliary hoist at the centre of gravity; ▣▣▣▣► p. 6 - 93.

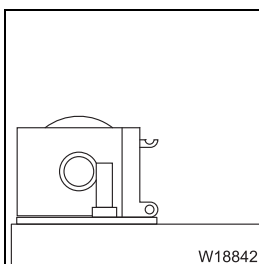

2. – Place the auxiliary hoist on the counterweight combination or the rigging frame; ▣▣▣▣► p. 6 - 98.





**Risk of accident when the safety valve is open!**

Always close the safety valve when the auxiliary hoist is locked to the turntable!

This prevents the auxiliary hoist from falling down due to unintentional actuation of the locking cylinders.

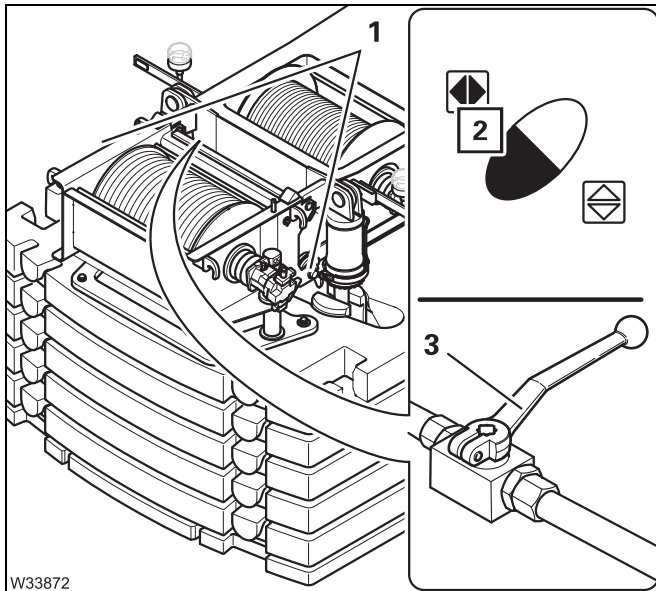

**Extending the locking cylinders**

- Press the buttons (2) until the locking cylinders (1) are fully extended.
- Close the safety valve (3) – lever at right angles to the line.

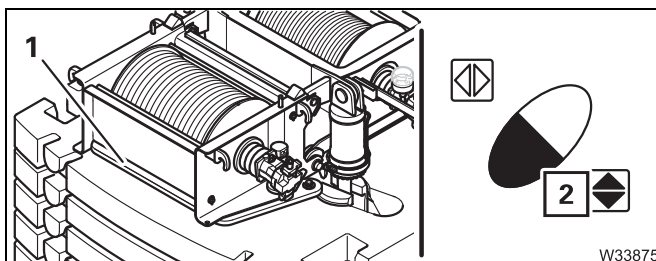

**Lifting the lifting frame**

- Press the buttons (2) until the lifting frame (1) is fully retracted.



## 7.2

### What to do when a malfunction occurs in road traffic

If the truck crane can no longer be driven due to an accident or another malfunction, observe the following.

- Keep calm!
- Stop the truck crane! Observe the traffic behind you!
- Stop at a place safe for you and for the traffic behind you!



#### **Risk of accidents due to poor visibility!**

If possible, do not stop in a tunnel or directly after a curve.

- Secure the truck crane in compliance with the legal regulations applicable in the country in which you are working.



#### **Risk of accidents during repair work in danger areas!**

In hazard areas (e.g. tunnels, intersections, motorway bridges), even simple repairs can be dangerous.

When in a hazard area, carry out only the repair work required to leave the danger area.

If you are unable to repair the damage yourself, notify **Manitowoc Crane Care** or have the truck crane towed;  *Towing the truck crane*, p. 7 - 5.

## 7.4

## Wheels and tyres

This section contains all the information about changing a wheel and about using the tyre inflater connection.

### 7.4.1

### Wheel change

- If a puncture occurs while driving, stop the truck crane, taking the following traffic into account, and secure the truck crane as outlined in the applicable legal stipulations of the country in which you are working.
- Select as flat a place as possible to change the wheel.



#### **Risk of accidents due to a wheel falling over!**

If you temporarily lean a wheel against the truck crane while changing it, secure it with a rope to prevent it falling over!  
Move the outriggers only when no wheel is leaning against the truck crane.

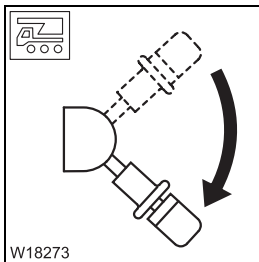

- Apply the parking brake.



### Group F6

Designation	Amperage (A)	Function
F6/1	5	Left-hand side marker lights and parking light
F6/2	10	Right-hand side marker lights <sup>1)</sup> and parking light
F6/3	10	marker light and tail lamps, left-hand instrument lighting
F6/4	5	Right-hand marker light and tail lamps
F6/5	5	Left full-beam headlight
F6/6	5	Right-hand full beam headlight, indicator lamp for full beam headlight
F6/7	5	Headlight, left
F6/8	5	Headlight, right

### Group F7

Designation	Amperage (A)	Function
F7/1	2	Control unit ESX 4
F7/2	5	ESX 4 sensors, Fuse monitoring
F7/3	20	Control unit ESX 4
F7/4	2	Control unit ESX 5
F7/5	5	ESX 5 sensors, Fuse monitoring
F7/6	20	Control unit ESX 5
F7/7	7.5	Fog light <sup>1)</sup>
F7/8	7.5	Rocker





<sup>1)</sup> Additional equipment

### Group F8

Designation	Amperage (A)	Function
F8/1	5	Fixed voltage controller 5 V



## 7.6.7 Differential lock malfunctions

Malfunction	Cause	Remedy
<b>Differential locks cannot be switched on</b>	Current speed above approx. 5 km/h	Slow down or stop the truck crane
	Drive train under tension	Slowly drive the truck crane back and forth,  p. 5 - 62
	Compressed air system insufficiently filled	 <i>Building up supply pressure</i> , p. 5 - 10
	Fuses F2/1, F4/6, F5/4, F5/7 blown	Replace blown fuses;  p. 7 - 20
<b>Differential locks cannot be switched off</b>	Current speed above approx. 5 km/h	Slow down or stop the truck crane
	Drive train under tension	Slowly drive the truck crane back and forth,  p. 5 - 62
<b>Error symbol is displayed</b>	ECOS malfunction	Read out error messages (  p. 7 - 35) and notify <b>Manitowoc Crane Care</b>

## 7.6.8 Malfunctions in the hydraulic system/hydraulic oil cooler

Malfunction	Cause	Remedy
<b>Hydraulic oil temperature above 80 °C , fan in the hydraulic oil cooler is running</b>	Hydraulic system under extreme strain and ambient temperature very high	Stop the truck crane while taking the traffic situation into account and run the engine until the oil has cooled down
<b>Hydraulic oil temperature above 80 °C, fan in the hydraulic oil cooler is not running</b>	Fuse F1/3 blown	Stop the truck crane while taking the traffic situation into account, and replace the defective fuse;  p. 7 - 20.
	Defective temperature sensor in the hydraulic system (error message is displayed)	Have the temperature sensor replaced

**8 Index**

Malfunctions .....	7 - 27
Operation in the driver's cab	
Checking after starting .....	4 - 18
Checking the fuel level .....	4 - 7
Checks before starting .....	4 - 10
Lamp test / switching state alignment .....	4 - 12
monitoring elements .....	4 - 20
Resetting the emergency stop switch .....	4 - 24
Setting idling speed .....	4 - 22
Starting .....	4 - 15
Starting - CHECKLIST .....	4 - 1
Switch on the ignition .....	4 - 11
switching off .....	4 - 23
preheating .....	5 - 80
procedure during malfunctions .....	7 - 39, 7 - 40
Refuel .....	4 - 7
Starting from the crane cab - for rigging work .....	12 - 23
Starting/switching off from the outrigger control units - for rigging work ..	12 - 26
<b>F</b> Final drive	
Operating elements in the driver's cab .....	3 - 53
Front flap	
Opening and closing .....	3 - 72
Fuel tank	
Engine for crane operation .....	10 - 4
Standard tank .....	4 - 7
Fuses	
on the carrier .....	7 - 19
on the superstructure .....	14 - 5
<b>H</b> Hand-held control	
Disconnecting .....	12 - 21
Malfunctions .....	14 - 24
Heating system	
Crane cab	
Auxiliary air heater .....	11 - 142
Auxiliary water heater .....	11 - 135
Standard heating system .....	11 - 131
Driver's cab	
Auxiliary water heater .....	5 - 80
Standard heating system .....	5 - 75
High-speed mode .....	11 - 94
Derricking gear/telescoping mechanism high-speed mode .....	11 - 94
High-speed mode for hoists .....	11 - 95
Switch on function .....	11 - 94

Tyres	
see wheels and tyres	
<b>V</b>	<b>Voltage monitoring</b>
Superstructure .....	9 - 110
<b>W</b>	<b>Warning plates for vehicle width .....</b>
	5 - 9
	<b>Welding work</b>
Safety Instructions .....	2 - 4
	<b>Wheels and tyres</b>
Inflating the tyres yourself .....	7 - 17
Wheel change .....	7 - 13
	<b>Windscreen washing system</b>
Tank - driver's cab .....	5 - 7, 11 - 5
	<b>Windscreen wiper .....</b>
	3 - 60
Crane cab .....	9 - 113
Driver's cab .....	3 - 60
	<b>Windscreen wiper/washing system .....</b>
	9 - 111
	<b>Work break .....</b>
	11 - 129
In case of short work breaks .....	11 - 129
In case of work breaks of more than 8 hours .....	11 - 130
	<b>Working range limiter .....</b>
	11 - 115
Entering limit values by approaching them	
For objects .....	11 - 121
For overall height/working radius .....	11 - 118
for slewing angles .....	11 - 119
Entering limit values manually	
For objects .....	11 - 125
For overall height/working radius/slewing angle .....	11 - 124
Opening the working range limiter submenu .....	11 - 116
Shutdown .....	11 - 127
switching monitoring function on/off .....	11 - 126
View current settings .....	11 - 116

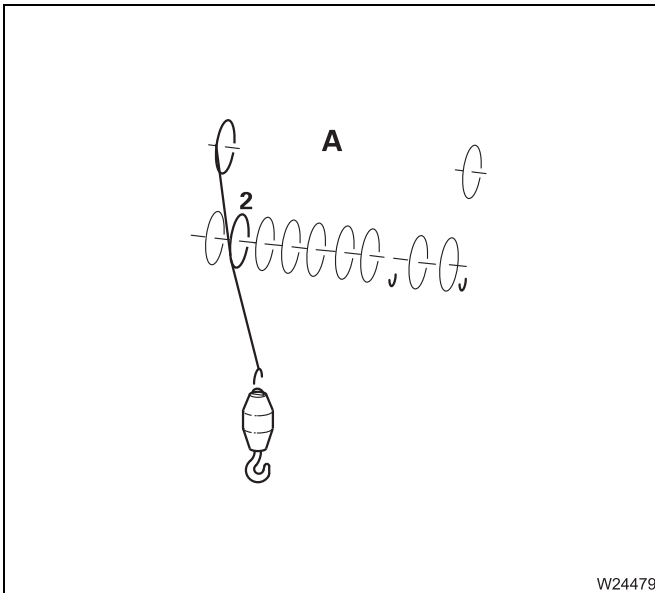

**Hook tackle**

- Reeving  
**A** 1x

**With 10 head sheaves**

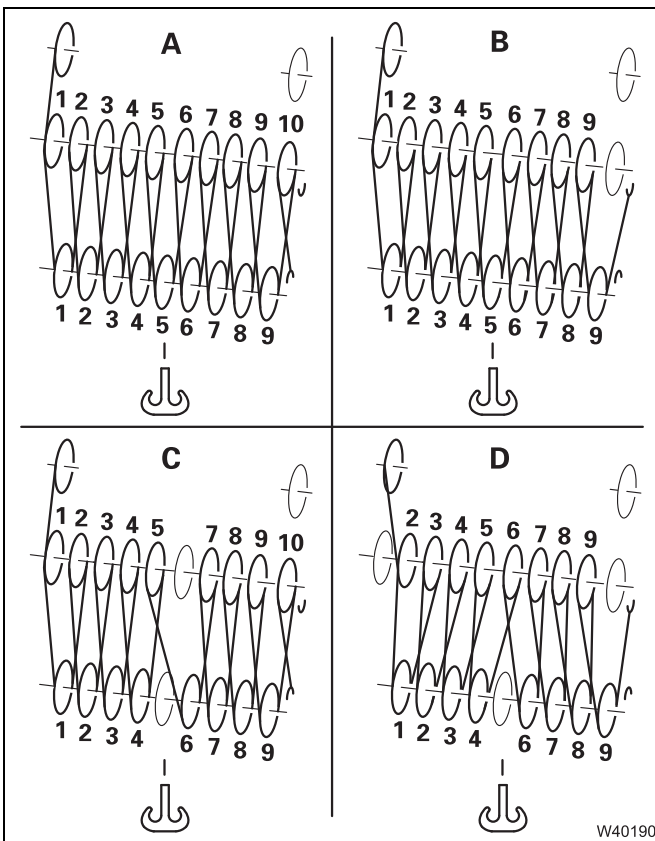

**9 sheave hook block**

- Reeving  
**A** 19x  
**B** 18x  
**C** 17x  
**D** 16x



---

**This operating manual is divided into two parts:**

**Part 1 – Driving**

**Part 2 – Crane operation**

**Content overview of Part 2:**

- 9 Operating elements for crane operation**
- 10 Starting/switching off the engine – for crane operation**
- 11 Crane operation**
- 12 Rigging work**
- 13 Driving with a rigged truck crane**
- 14 Malfunctions during crane operation**
- 15 Index**

**Chapters 1 to 8 are in Part 1 – Driving**

**This section alone is not equivalent to complete operating instructions.  
The basic safety instructions for crane operation  
are located in Section 1, Chapter 2.**

1	Camera monitor <sup>1)</sup>	▶▶▶▶ p. 12 - 117
2	Side panel	▶▶▶▶ p. 9 - 9
3	Front panel	▶▶▶▶ p. 9 - 8
4	Standard heating system	▶▶▶▶ p. 9 - 13
5	Control panels	▶▶▶▶ p. 9 - 16
6	Windscreen	▶▶▶▶ p. 9 - 118
7	Accelerator pedal	
8	Air vent	▶▶▶▶ p. 11 - 132
9	Storage compartment	
10	Windscreen washing system – Tank <sup>3)</sup>	▶▶▶▶ p. 11 - 5
11	Extendable step	▶▶▶▶ p. 12 - 122
12	Slewing gear freewheel <sup>1)</sup>	▶▶▶▶ p. 9 - 82
13	Cab lighting	▶▶▶▶ p. 9 - 112
14	Auxiliary water heating system	▶▶▶▶ p. 9 - 14
	Auxiliary air heater	▶▶▶▶ p. 9 - 15
15	Loudspeakers	
16	Radio/CD/USB <sup>1), 2)</sup>	
17	Console, rear	▶▶▶▶ p. 9 - 12
18	Fan with switch <sup>1)</sup>	
19	Rear window	▶▶▶▶ p. 9 - 118
20	Crane cab seat – Version 1	▶▶▶▶ p. 11 - 7
	Crane cab seat – Version 2	▶▶▶▶ p. 11 - 7
	Seat contact switch	▶▶▶▶ p. 9 - 62
21	Cover for	
	– Fuses	▶▶▶▶ p. 14 - 5
	– CraneSTAR system <sup>1)</sup>	▶▶▶▶ p. 11 - 144
22	Intake/air vents	▶▶▶▶ p. 11 - 131
23	Door lock	▶▶▶▶ p. 9 - 118
24	Handle	▶▶▶▶ p. 4 - 5
25	Door unlocking mechanism	▶▶▶▶ p. 9 - 118

1) Additional equipment

2) ▶▶▶▶ *Separate operating instructions*

3) ▶▶▶▶ *Maintenance Manual*

Right

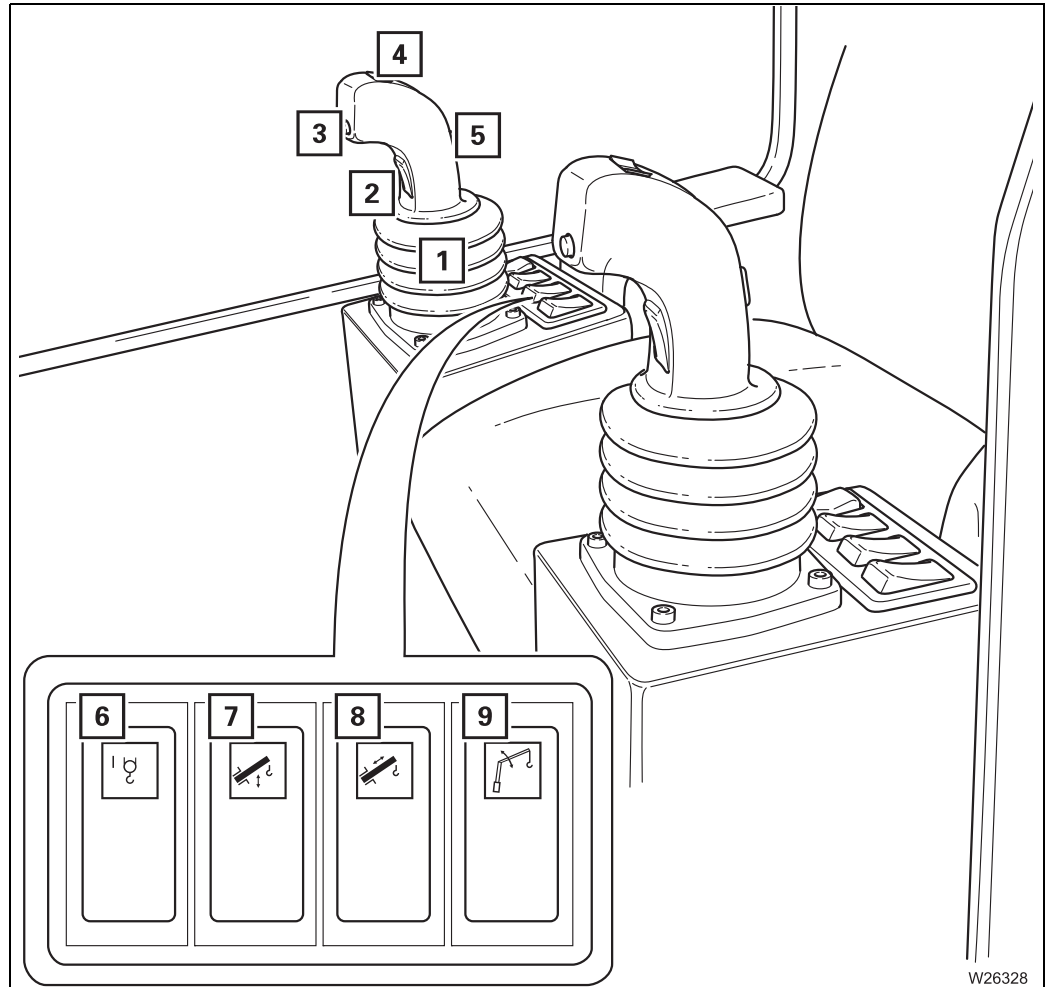

W26328

- |   |  |       |            |
|---|--|-------|------------|
| 1 | Right control lever (configuration according to execution) | ▣▣▣▣▶ | p. 9 - 18  |
| 2 | Dead man's switch  | ▣▣▣▣▶ | p. 9 - 62  |
| 3 | Horn button  |       |            |
| 4 | Hoist high-speed mode on/off                               | ▣▣▣▣▶ | p. 9 - 79  |
| 5 | Main hoist slewing indicator                               | ▣▣▣▣▶ | p. 11 - 55 |
| 6 | Main hoist on/off  | ▣▣▣▣▶ | p. 9 - 78  |
| 7 | Derricking gear on/off                                     | ▣▣▣▣▶ | p. 9 - 84  |
| 8 | Telescoping mechanism on/off                               | ▣▣▣▣▶ | p. 9 - 86  |
| 9 | Derrick lattice extension on/off <sup>1), 2)</sup>         |       |            |

<sup>1)</sup> Additional equipment

<sup>2)</sup> ▣▣▣▣▶ *Operating Instructions Lattice Extension*

<b>1</b>	All supporting cylinders	▶▶▶▶▶ p. 9 - 66
<b>2</b>	Front right-hand outrigger	▶▶▶▶▶ p. 9 - 66
<b>2.1</b>	Front right-hand outrigger pressure display <sup>1)</sup>	▶▶▶▶▶ p. 9 - 73
<b>3</b>	Right-hand supporting cylinder	▶▶▶▶▶ p. 9 - 66
<b>4</b>	Rear right-hand outrigger	▶▶▶▶▶ p. 9 - 66
<b>4.1</b>	Rear right-hand outrigger pressure display <sup>1)</sup>	▶▶▶▶▶ p. 9 - 73
<b>5</b>	Extending the outrigger beam	▶▶▶▶▶ p. 9 - 67
<b>6</b>	Retracting the outrigger beam	▶▶▶▶▶ p. 9 - 67
<b>7</b>	Rear supporting cylinder	▶▶▶▶▶ p. 9 - 66
<b>8</b>	Front supporting cylinder	▶▶▶▶▶ p. 9 - 66
<b>9</b>	Extend supporting cylinders	▶▶▶▶▶ p. 9 - 67
<b>10</b>	Retract supporting cylinders	▶▶▶▶▶ p. 9 - 67
<b>11</b>	Rear left-hand outrigger	▶▶▶▶▶ p. 9 - 66
<b>11.1</b>	Rear left-hand outrigger pressure display <sup>1)</sup>	▶▶▶▶▶ p. 9 - 73
<b>12</b>	Left-hand supporting cylinder	▶▶▶▶▶ p. 9 - 66
<b>13</b>	Front left-hand outrigger	▶▶▶▶▶ p. 9 - 66
<b>13.1</b>	Front left-hand outrigger pressure display <sup>1)</sup>	▶▶▶▶▶ p. 9 - 73
<b>14</b>	Switching over the measuring range	▶▶▶▶▶ p. 9 - 70
<b>15</b>	Current inclination display	▶▶▶▶▶ p. 9 - 70
<b>16</b>	Angle direction display	▶▶▶▶▶ p. 9 - 70
<b>17</b>	Slewing gear/movements locked display	▶▶▶▶▶ p. 9 - 66
<b>18</b>	Carrier ignition display	▶▶▶▶▶ p. 9 - 61
<b>19</b>	Display for engine for driving on/off	▶▶▶▶▶ p. 9 - 61
<b>20</b>	Start engine for driving	▶▶▶▶▶ p. 9 - 61

<sup>1)</sup> Additional equipment



CLICK HERE TO **DOWNLOAD** THE COMPLETE MANUAL

- Thank you very much for reading the preview of the manual.
- You can download the complete manual from: [www.heydownloads.com](http://www.heydownloads.com) by clicking the link below



- Please note: If there is no response to CLICKING the link, please download this PDF first and then click on it.

CLICK HERE TO **DOWNLOAD** THE COMPLETE MANUAL

## Error submenu

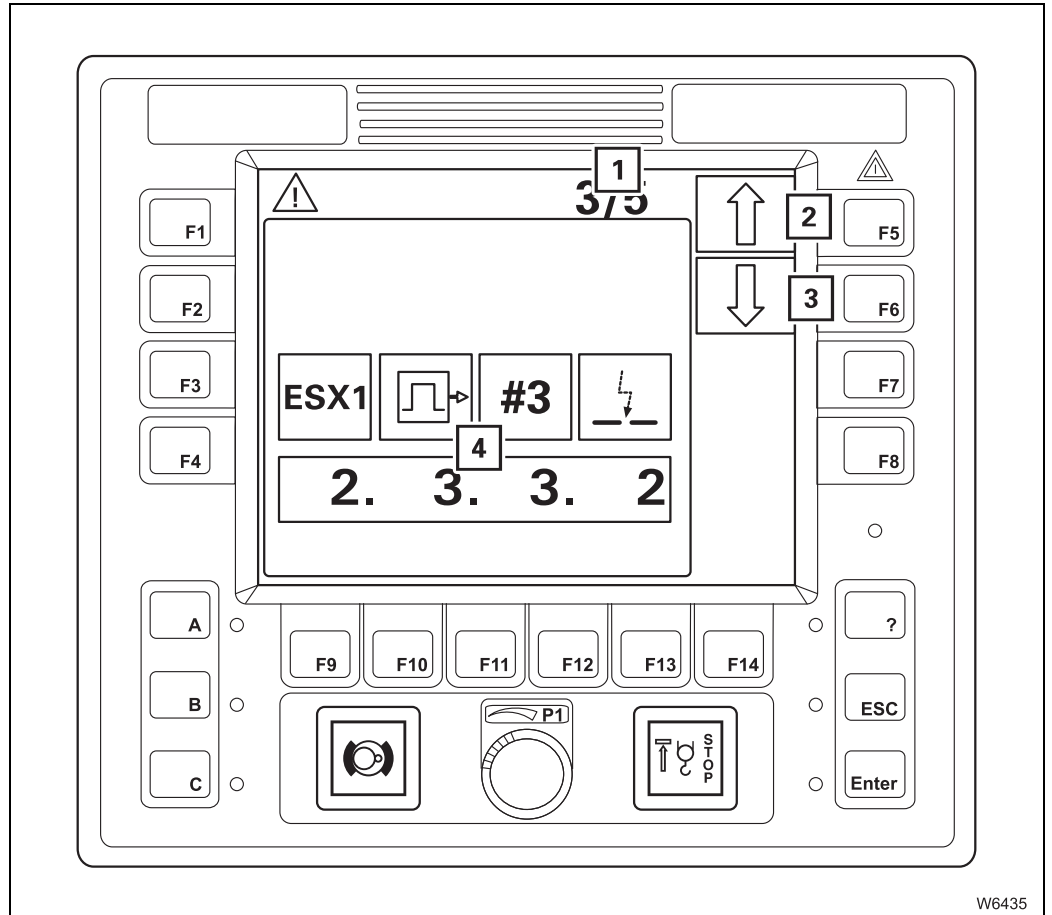

W6435

- |   |                                     |                  |
|---|-------------------------------------|------------------|
| 1 | Current errors/total errors display | ▣▣▣▣▶ p. 14 - 36 |
| 2 | Next error                          | ▣▣▣▣▶ p. 14 - 36 |
| 3 | Previous error                      | ▣▣▣▣▶ p. 14 - 36 |
| 4 | Error display                       | ▣▣▣▣▶ p. 14 - 36 |



## Lifting capacity table submenu

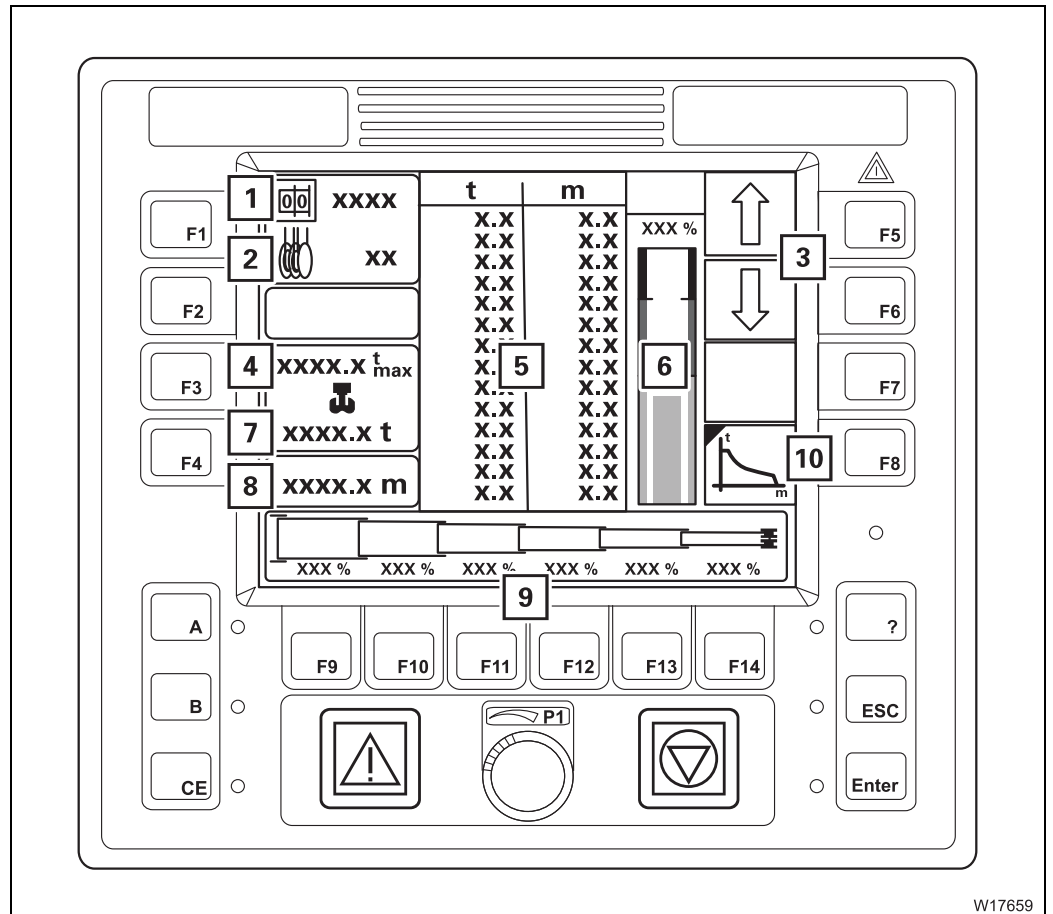

W17659

- |    |                                       |      |            |
|----|---------------------------------------|------|------------|
| 1  | Display RCL code                      | ▣▣▣▣ | p. 9 - 106 |
| 2  | Reeving display                       | ▣▣▣▣ | p. 9 - 106 |
| 3  | Selection                             |      |            |
| 4  | Maximum load display                  | ▣▣▣▣ | p. 9 - 106 |
| 5  | Lifting capacity table display        | ▣▣▣▣ | p. 9 - 106 |
| 6  | Current degree of utilisation display | ▣▣▣▣ | p. 9 - 106 |
| 7  | Current load display                  | ▣▣▣▣ | p. 9 - 106 |
| 8  | Current working radius display        | ▣▣▣▣ | p. 9 - 106 |
| 9  | Telescope status display/input        | ▣▣▣▣ | p. 9 - 106 |
| 10 | Working range submenu <sup>1)</sup>   | ▣▣▣▣ | p. 9 - 48  |

<sup>1)</sup> Additional equipment



## 9.2

## Short description of the operating elements



### Risk of accident by operator error!

This section is not a complete operating manual. It only provides a general overview of the functionality of the operating elements.

Before using the operating elements for the first time, read through the following chapters and the safety instructions listed there.



This section does not contain all the requirements that must be fulfilled for several operating elements to be active.

If some operating elements do not work, first read the following chapters which are referred to at the respective places before contacting

**Manitowoc Crane Care.**

### 9.2.1

### Definition of direction information

#### Basic rule

Direction information always depends on whether the carrier or the superstructure is being operated.

#### On the carrier

The driver's cab is always at the front, which means that:

- |          |          |
|----------|----------|
| 1: front | 2: right |
| 3: rear  | 4: left  |

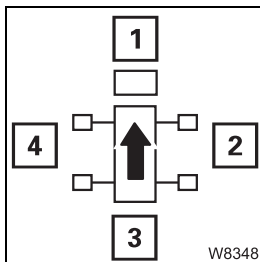

**Forwards** always means with the driver's cab leading,

**Backwards** always means with the rear lights on the carrier leading.

#### On the superstructure

The main boom head is always at the front, which means that:

- |          |          |
|----------|----------|
| 1: front | 2: right |
| 3: rear  | 4: left  |

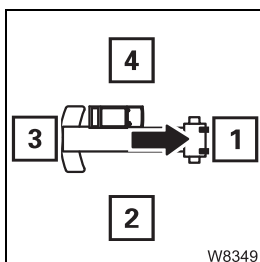

### Retract/extend outrigger beam/supporting cylinder

Slewing gear is switched off – outrigger pre-selection on.

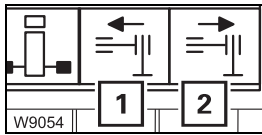

**1 Retract:** Press button – outrigger beam retracts

**2 Extend:** Press button – outrigger beam extends

➡ p. 12 - 37

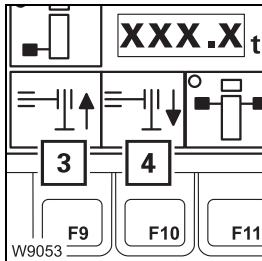

**3 Retract:** Press button – outrigger cylinder retracts

**4 Extend:** Press button – outrigger cylinder extends

➡ p. 12 - 43

Movement stops after the button is released and when an end position is reached.

### In the Settings submenu

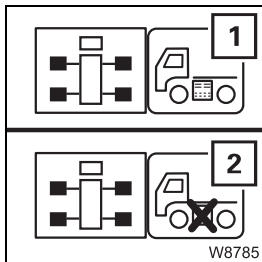

### Outrigger control units on/off

– **To switch on:** Press button until symbol (1) appears

– **To switch off:** Press button until symbol (2) appears

➡ p. 12 - 31



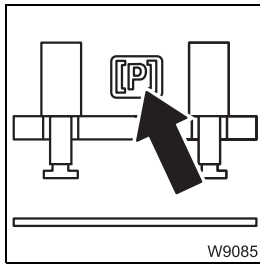

### Pre-tensioning pressure display

- **Green:** Pre-tensioning pressure reached
  - **Red:** Pre-tensioning pressure too low – pre-tension counterweight
- ▣▣▣▣ p. 12 - 77

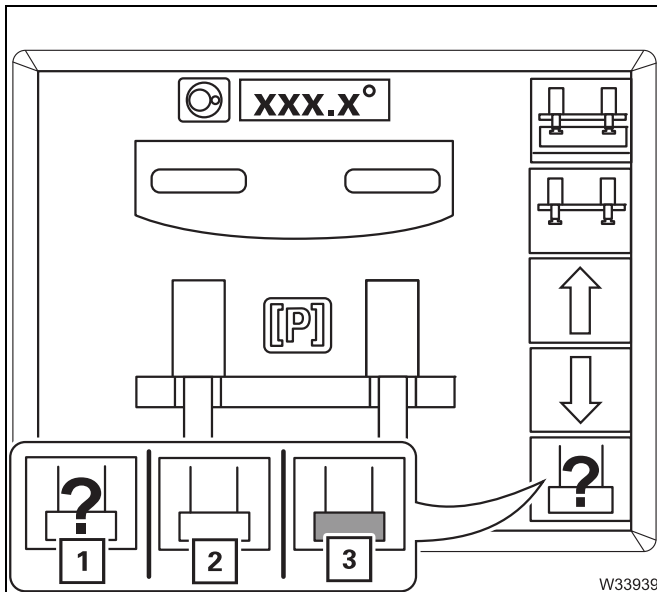

### Counterweight recognition

The different states of the counterweight detection system are shown by three symbols.

- 1 No weight detected – counterweight lowered or unrigged
- 2 Weight being calculated – when raising the counterweight
- 3 Weight detected – counterweight raised and pretensioned. No other counterweight combination can be entered.

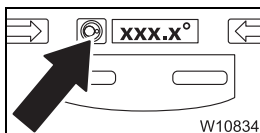

### Slewing gear display

Identical with the display in the *Slewing gear/Houselock* submenu;  
▣▣▣▣ p. 9 - 83.

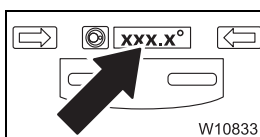

### Current slewing angle display

Identical with the display in the *Slewing gear/Houselock* submenu;  
▣▣▣▣ p. 9 - 83.

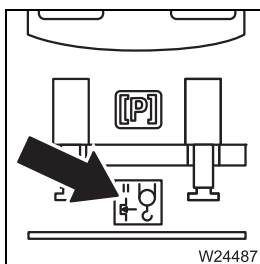

### Auxiliary hoist lock display

Identical with the display in the *Slewing gear/Houselock* submenu;  
▣▣▣▣ p. 9 - 83.  
▣▣▣▣ *Counterweight hoist unit*, p. 12 - 75

## Submenu

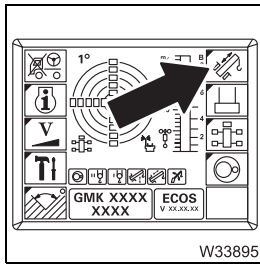

### Telescoping submenu

- **To open:** Press button once – submenu opens

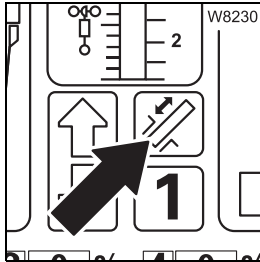

### Display for telescoping mechanism on/off

- **Green:** Telescoping mechanism on
- **Red:** Telescoping mechanism off

➡ p. 11 - 77

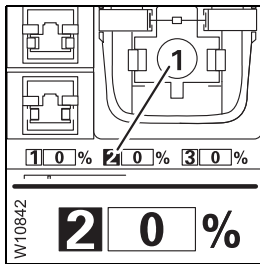

### Current telescope status display

- 1 Extended length of the telescopic sections in per cent (%)
- 2 Telescopic section display is green

- **On:** Telescoping cylinder is locked here
- **Flashing:** Next possibility for locking telescoping cylinder

➡ p. 11 - 78

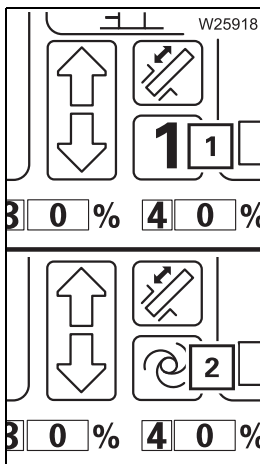

### Telescoping cylinder in the telescopic section display

Displayed telescopic section, e.g. telescopic section I:

- 1 - **On:** Telescoping cylinder is locked here
- 1 - **Flashing:** Next possibility for locking telescoping cylinder
- 1 - **Off:** Telescoping cylinder in this telescopic section – distance to the locking point greater than 1 m  
**or**  
Teleautomation on – symbol (2) is displayed

➡ p. 11 - 78



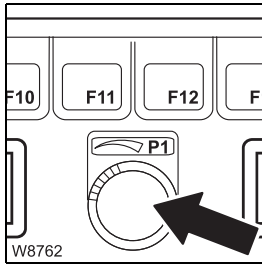

### Entering values

The input mode for the RCL code is switched on.

- **To the right:** Next greater value
- **To the left:** Next smaller value

Slowly turning – changes the value gradually  
Quickly turning – changes the value quickly

▣▣▣▣ p. 11 - 28

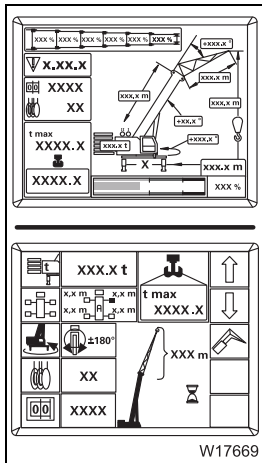

### Display RCL

- **After a standstill of up to 48 hours**

Ignition on – *Monitoring* submenu opens; ▣▣▣▣ p. 11 - 21

- **After a standstill of more than 48 hours**

Ignition on – *Enter rigging mode* submenu opens; ▣▣▣▣ p. 11 - 22

### Main menu

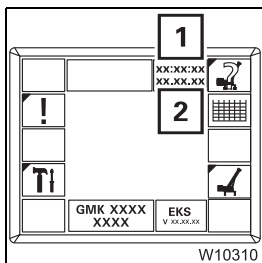

### Date/time display

- 1 Time
- 2 Date

▣▣▣▣ *Entering the time/date*, p. 11 - 49

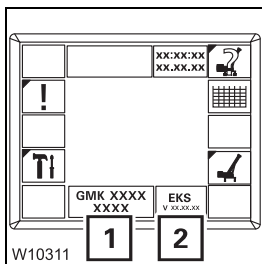

### Serial number and program version displays

- 1 Truck crane serial number
- 2 RCL program version – always state in the event of malfunctions;  
▣▣▣▣ p. 14 - 26



## Working range submenu

▣▣▣▣ ▶ *Displaying the lifting capacity tables, p. 11 - 47*

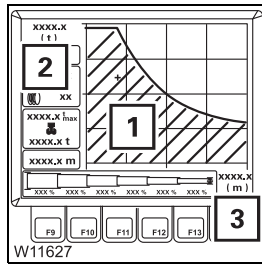

### Permissible working range display

Applies for displayed RCL code and displayed telescope status

- 1 Permissible working range – surface under the curve
- 2 Maximum possible load
- 3 Maximum possible working radius

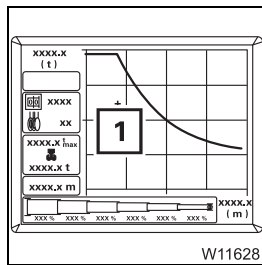

### Current position display

- 1 Current position – defined by current load and current working radius

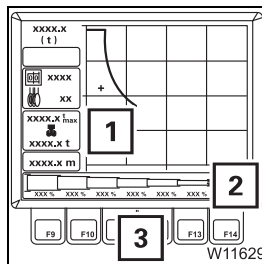

### Telescope status display/input

- **Display:** Telescope status (2) in per cent
- **Input:** Press button (3)
  - New telescope status on display (2)
  - Corresponding working range on display (1)
  - or no display = telescope status outside the working range

### Other displays

Similar functionality to the *Lifting capacity table* submenu

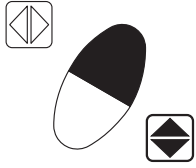
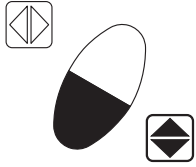
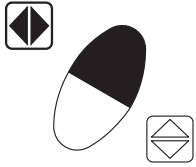
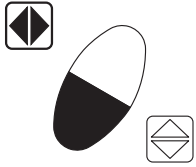

Button combination	Pre-selected power unit				
	Telescoping mechanism	Derricking gear	Slewing gear	Hoists	Lattice extension
 W3851	None	from the cabin	None	Lower	from the cabin
 W3850	Retract	Raise	None	Lift	Raise
 W3849	None	None	Slew to the right	None	None
 W3848	None	None	Slew to the left	None	None

Emergency operation with the hand-held control, p. 14 - 59

Only use permissible consumables;  *Separate engine operating instructions, provided by the manufacturer.*



**Danger of fire due to inflammable gases!**

Switch off the engine, the heater and all additional heaters before refuelling.



**Risk of accidents if the tank is not closed!**

Close the tank each time you have refilled it.  
In this way you can prevent other vehicles from being endangered by the cap falling off or consumables escaping.



**Risk of damage to the engine and catalytic converter!**

Unauthorised consumables can damage the engine and catalytic converter and void the warranty. Only use consumables approved by the engine manufacturer.

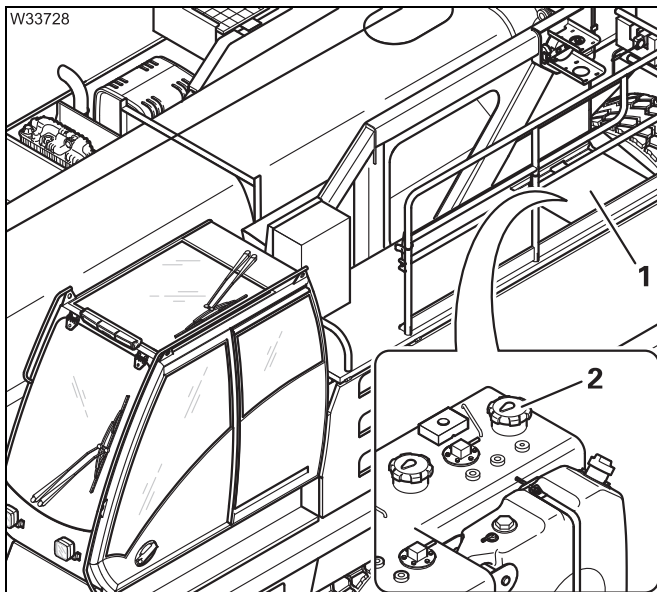

- Open the cover (1).
- Fill in the fuel through the filler neck (2) in time. Leave sufficient space for the fuel to expand.
- Close the filler neck each time you have refuelled (2).
- Close the cover (1).



## 10.1.10 Monitoring submenu

The *Monitoring* submenu shows the most important measured values.

- If necessary, open the main menu  and press the button **(1)** once.

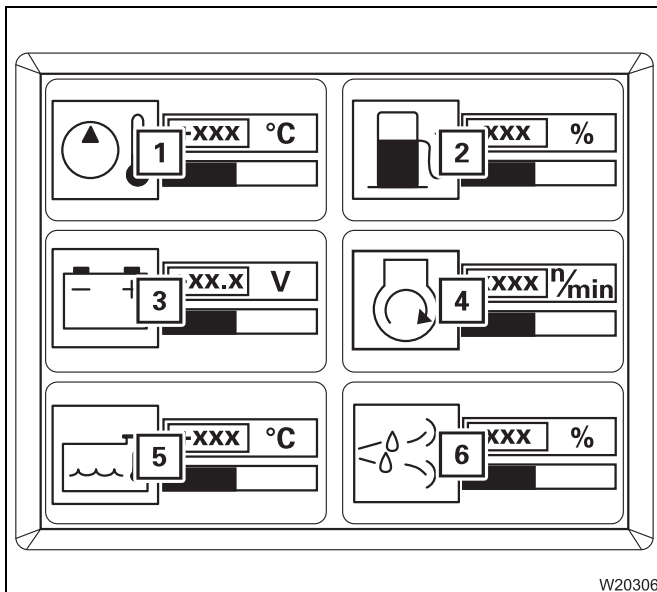
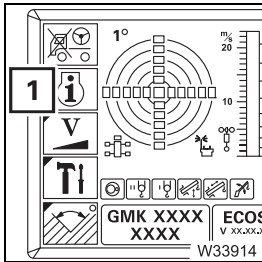

This opens the *Monitoring* submenu.

The following values are displayed:

- 1 The hydraulic oil temperature in °C
- 2 Fuel supply in percent
- 3 Voltage in volts
- 4 The engine speed in
- 5 The coolant temperature in °C
- 6 Carbamide supply in percent

The colour of the bar below the values indicates in which area the value can be found.

**Green:** Value OK.

**Yellow:** Limit value almost reached

**Red:** Limit value exceeded (or not reached) – warning message;  
 p. 11 - 110.

## 11 Crane operation

<b>11.1</b>	<b>Before operating the crane</b> . . . . .	11 - 1
11.1.1	CHECKLIST: Checks before operating the crane . . . . .	11 - 1
11.1.2	Checking the condition of the truck crane . . . . .	11 - 5
11.1.3	Adjusting the crane cab seat and front control panel . . . . .	11 - 7
11.1.4	Checking the safety equipment . . . . .	11 - 9
11.1.5	Earthing the load. . . . .	11 - 12
11.1.6	Preheating the hydraulic oil . . . . .	11 - 13
11.1.7	Locking/unlocking the turntable . . . . .	11 - 14
11.1.8	Switching the houselock on/off . . . . .	11 - 15
<b>11.2</b>	<b>Operation of the rated capacity limiter</b> . . . . .	11 - 19
11.2.1	Switch on the RCL . . . . .	11 - 20
11.2.2	Enter rigging mode . . . . .	11 - 23
11.2.3	Checks before operating the crane . . . . .	11 - 31
11.2.4	Displays during crane operation . . . . .	11 - 34
11.2.5	RCL early warning . . . . .	11 - 37
11.2.6	RCL shutdown . . . . .	11 - 37
11.2.7	Display in the event of errors . . . . .	11 - 39
11.2.8	RCL override . . . . .	11 - 40
11.2.9	Displaying the lifting capacity tables . . . . .	11 - 47
11.2.10	Entering the time/date . . . . .	11 - 49
<b>11.3</b>	<b>Crane operation with main boom</b> . . . . .	11 - 51
11.3.1	Checks during crane operation . . . . .	11 - 51
11.3.2	Permissible slewing ranges and working positions . . . . .	11 - 53
11.3.3	Main hoist . . . . .	11 - 54
11.3.4	Auxiliary hoist . . . . .	11 - 57
11.3.5	Lifting limit switch and lowering limit switch . . . . .	11 - 60
11.3.6	Derricking gear . . . . .	11 - 62
11.3.7	Telescoping mechanism . . . . .	11 - 66
11.3.8	High-speed mode . . . . .	11 - 94
11.3.9	Slewing gear . . . . .	11 - 96
11.3.10	Possible movement combinations . . . . .	11 - 101
11.3.11	Hydraulic oil cooling . . . . .	11 - 101



## 11.1.4

### Checking the safety equipment



#### **Risk of accidents when working with faulty safety devices!**

It is prohibited to operate the crane with safety devices that are faulty, overridden or out of service!

Have faulty safety devices repaired immediately by **Manitowoc Crane Care**.

#### **Rated capacity limiter**

- Switch on the rated capacity limiter, do all of the checks and enter the current rigging mode;  *Switch on the RCL*, p. 11 - 20.

The RCL is working correctly at this point in time if no error message is pending and if crane movements have been enabled.

If the RCL is not working correctly, do not start work with the crane but notify **Manitowoc Crane Care**.

#### **Lifting limit switch**

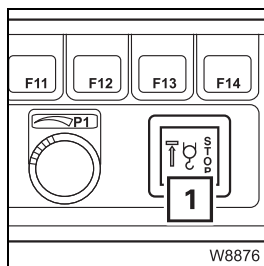

- Raise the main boom until the hook block is lifted off the ground.
- Slowly perform the *Raise* movement until the hook block lifts the lifting limit switch weight.
- Now check that the *Raise* movement is switched off and the lamp (1) lights up.
- Check that the *Lower* and *Extend* movements are also switched off.

The lifting limit switch is working correctly at this point in time if the lamp (1) lights up and the movements *Raise*, *Lower* and *Extend* are switched off.

If the lift limit switch is not working correctly, do not start work with the crane but notify **Manitowoc Crane Care**.



## 11.2

### Operation of the rated capacity limiter

The rated capacity limiter is abbreviated to RCL (**R**ated-**C**apacity-**L**imiter) in these operating instructions.

If the truck crane's current rigging mode is registered properly, the RCL will prevent the permissible lifting capacity from being exceeded and the truck crane from being overloaded.



#### **Risk of accidents due to an incorrectly set RCL!**

Before operating the crane, ensure that the current rigging mode is correctly entered. An incorrect entry will give you a false sense of security. This may result in the truck crane overloading and causing an accident!

The current rigging mode is based on measured values and manually entered values.

Registered based on measured values	Registered based on manually entered values
<ul style="list-style-type: none"> <li>– Main boom length</li> <li>– Main boom angle</li> <li>– Current load</li> <li>– Outrigger span<sup>1)</sup></li> <li>– Lattice extension angle<sup>3)</sup></li> </ul>	<ul style="list-style-type: none"> <li>– Counterweight</li> <li>– Reeving</li> <li>– Outrigger span<sup>2)</sup></li> <li>– Length of lattice extension</li> <li>– Angle of the lattice extension<sup>4)</sup></li> </ul>

1) For versions without outrigger span monitoring

2) For versions with outrigger span monitoring

3) Lattice extension – luffable

4) Lattice extension – inclinable

During the operation of the crane, a visual and acoustic early warning is issued before the load limit is reached and then the functions are shut down that would lead into the overload range.



#### **Risk of accidents due to overridden or faulty RCL!**

The RCL must never be overridden.

It is prohibited to work if the RCL is switched off, overridden, out of service or faulty!



#### **Danger of overturning in two-hook operation!**

The rated capacity limiter only ensures safety for single hook operation! Two-hook operation is not permitted.

### Entering the reeving

Entering the reeving does not have an effect on any other component that has already been entered.

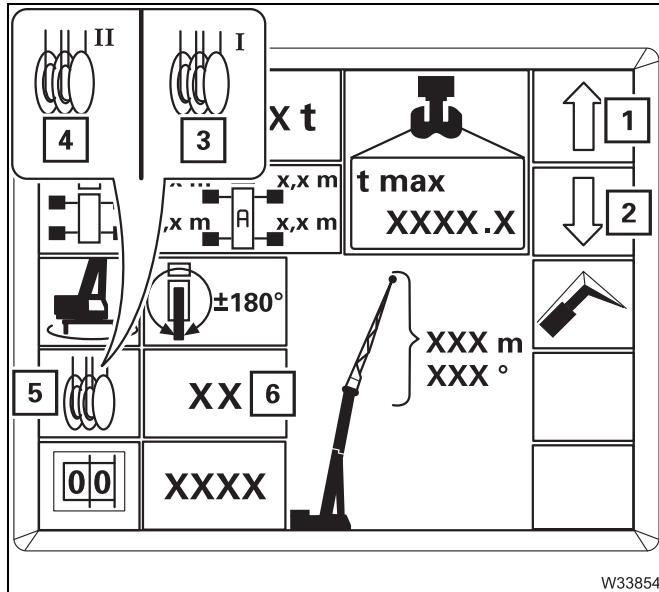

- Press button (5) repeatedly until the symbol for the hoist with which you want to lift the load has turned **green**.
  - 3 Symbol for main hoist
  - 4 Symbol for auxiliary hoist
- Press button (1) or (2) repeatedly until display (6) shows the number of currently reeved rope lines.

### Accepting the rigging mode

Prior to crane operation, you must confirm and accept the newly entered rigging mode.



### Confirming the rigging mode

- Press the button (2) once.
  - If the rigging mode is permissible, lamp (1) will go out. The *Rigging mode monitoring* submenu will open and you can accept the rigging mode.
  - If the rigging mode is not permissible, lamp (1) will light up. Press button (2) once to display the error codes; see p. 14 - 31.

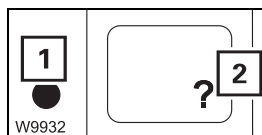

## 11.2.7 Display in the event of errors

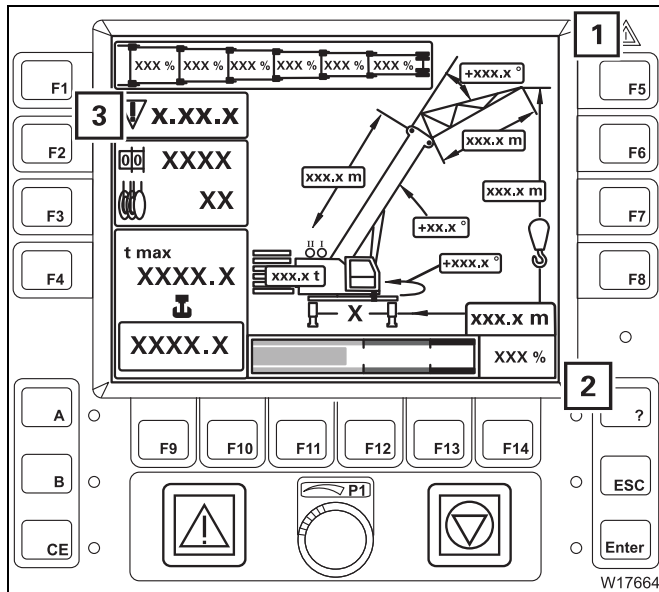

If an error occurs, it will be displayed as follows.

- Depending on the type of error, the buzzer tone sounds once or as a continuous buzzer tone.
- Lamps (1) and (2) light up.
- Display (3) shows an error code and the associated symbol flashes.

Further indications depend on the type of error; Error messages in the Monitoring submenu, p. 14 - 27.

## 11.2.10 Entering the time/date

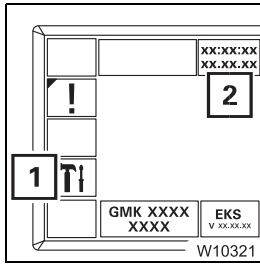

You can enter the time and date for the display (2).

- Press the button (1) once.

This opens the *Settings* submenu

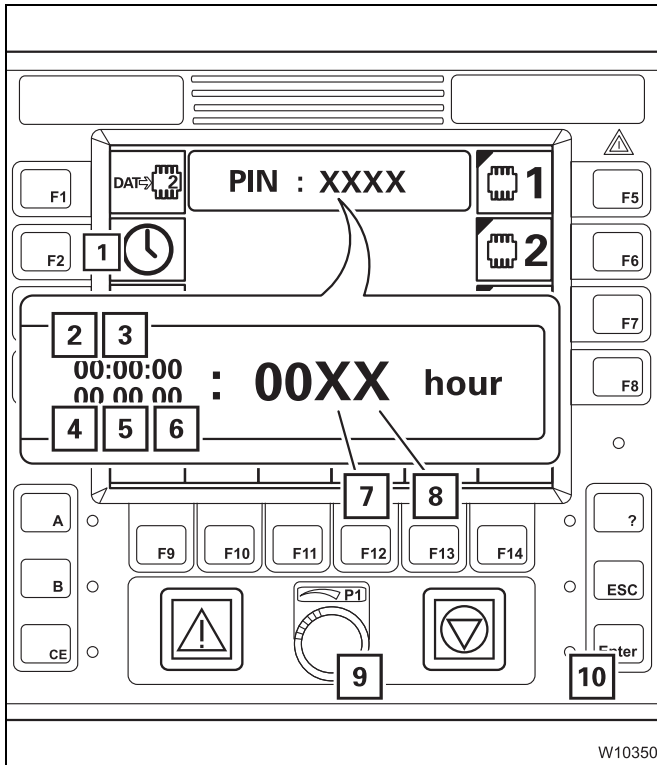

- Press button (1) repeatedly until the desired value flashes.

- 2 Hours
- 3 Minutes
- 4 Day
- 5 Month
- 6 Year

- Enter the new value with the buttons (7) and (8) or with the switch (9).
- Enter all the required values.
- Press button (10) once – the newly entered values will be accepted and displayed in the main menu.

Illogical values (e.g. 77 minutes) will not be accepted and the display will continue to flash.



You can **cancel the input** at any time. Press the button (1).  
None of the values will be changed.



## Lifting and lowering

You can adjust the sensitivity of the control levers to the operating conditions;  *Setting the characteristic curves for the control levers*, p. 11 - 106.



### Risk of accidents due to gaps in monitoring!

Operation of the hoist will only be monitored fully if:

- the lifting limit switch is correctly rigged;  p. 12 - 106,
- the lifting limit switch is not overridden;  p. 11 - 60,
- the lowering limit switch is correctly set;  p. 11 - 60.



### Risk of accidents due to suspended loads!

Never switch off the engine whilst a load is suspended. You must have the control levers at hand in order to intervene at any time.

Always set down the load before you leave the crane cab.

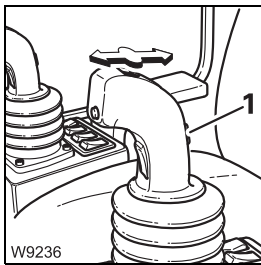



**Raise:** • Pull the control lever backwards.

**Lowering:** • Push the control lever forwards.

When the hoist drum is turning, you will notice a pulse on the slewing indicator (1).

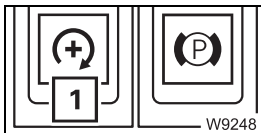
You can regulate the speed by moving the control lever and changing the engine speed with the accelerator.



You can set the desired engine speed (idling speed) with button (1);  p. 10 - 16.

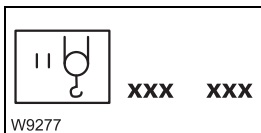

You can limit the maximum hoist speed;  p. 11 - 105.



You can switch on high-speed mode for a higher speed;  p. 11 - 94.

## Switching off the auxiliary hoist

If the auxiliary hoist is not required, it should be switched off to avoid unintentional use.

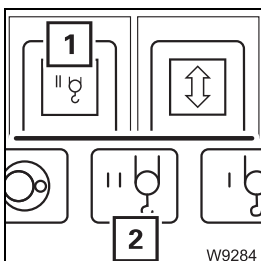

• Press the button (1) once.

- The lamp in the button (1) lights up dimly.
- Symbol (2) is **red** when the auxiliary hoist is switched off.

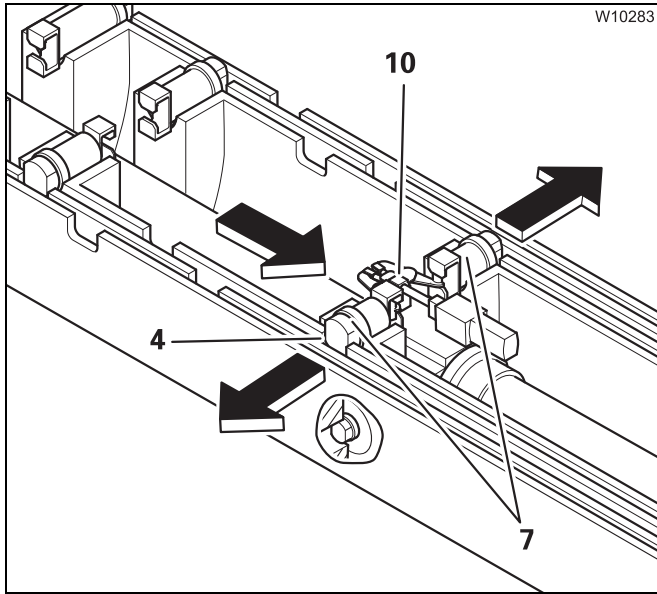

#### 4. Telescoping, locking and setting down a telescopic section

The telescoping cylinder pushes the telescopic section to a locking point.

The weight is taken off the mechanism (10).  
The locking pins (7) extend into the cutouts (4).

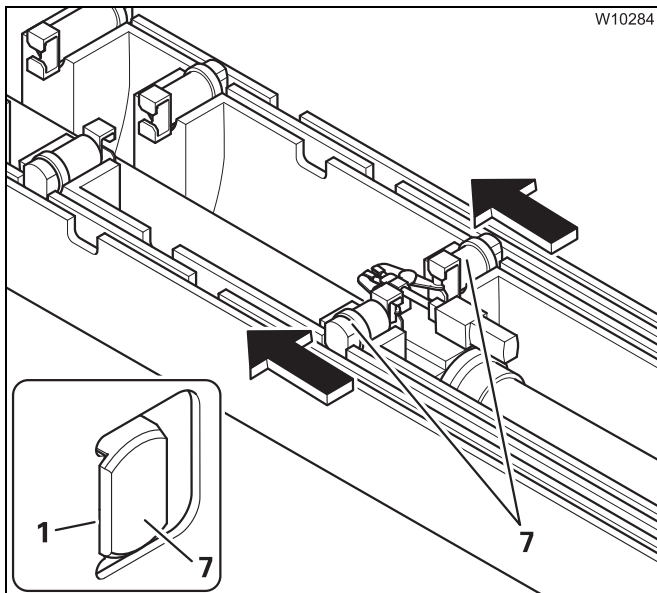

The telescopic section is automatically set down.

The telescoping cylinder retracts until the locking pins (7) are positioned on the above telescopic section (1).

The weight of the load is now on the telescopic sections and not on the telescoping cylinder.

#### Assignment for display

The *Telescoping* submenu of the *ECOS* display shows two sectional views of the main boom.

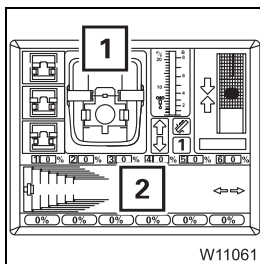

- 1 Sectional view from the rear
- 2 Sectional view from above

The following elements are displayed.



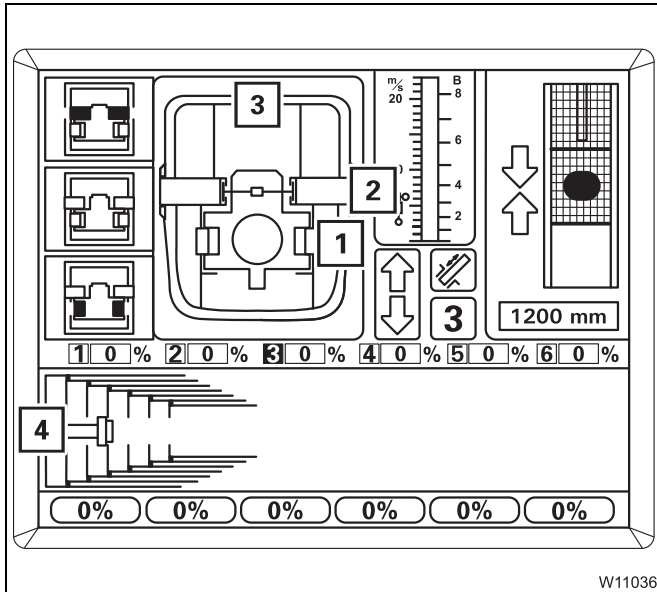

### Position of the locking pins

The display (3) shows the current positions of the locking pins

- 1 On the telescoping cylinder
- 2 On the telescopic section.

The current settings are shown in different colours.

- **Red:** Unlocked
- **Green:** Locked
- **Yellow:** Intermediate position

The display (4) shows the same settings:

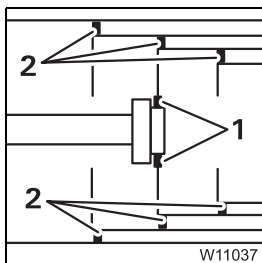

- 1 Locking pins on the telescoping cylinder
- 2 Locking pins on the telescopic sections

The settings are shown as follows:

- **Green:** Locked
- **No display:** Unlocked or intermediate position

### Unlocking the telescoping cylinder

Unlocking the telescoping cylinder is required for the telescoping cylinder to be moved separately (without telescopic section).

The telescoping cylinder and the telescopic section cannot be unlocked simultaneously.

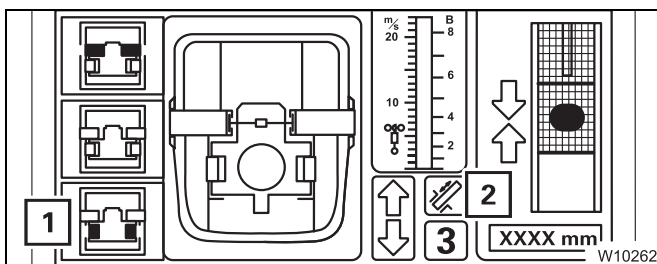

### Prerequisites

- Telescoping mechanism on – symbol (2) is green
- Telescoping cylinder locked – symbol (1) is grey



## Telescoping with teleautomation

When telescoping with teleautomation, you enter the desired fixed lengths and then move the control lever in the required direction. Switching between the telescopic sections is carried out automatically by ECOS.



If the desired telescoping status is not a fixed length, you can first telescope to the next closest fixed length with the teleautomation and then telescope further to the desired length manually.

- Switch the telescoping mechanism on and open the *Telescoping* submenu; p. 11 - 74.

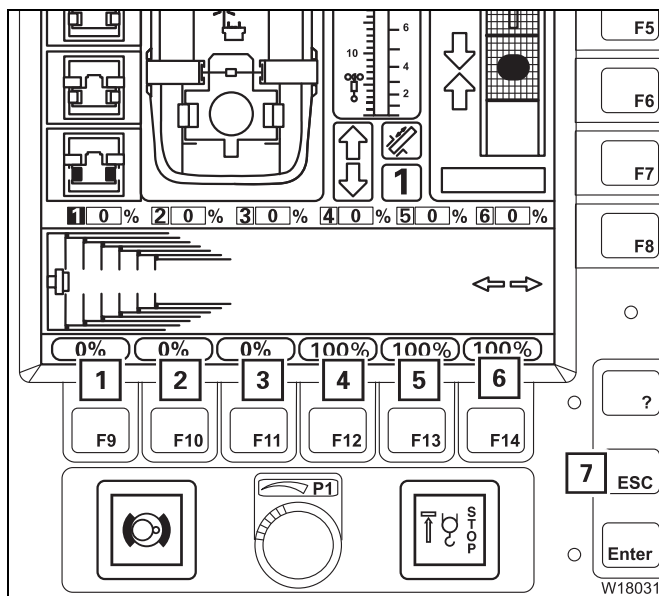

### Display

(1) to (6) – desired telescope status = objective of teleautomation:

- Red values: Teleautomation off,
- No values: Teleautomation disabled

### Entering the telescoping status

- Press one of the buttons (1) to (6). Values are **yellow** – input on.

To cancel input – press button (7) once.

- Enter the telescope status using buttons (1) to (6), e.g. 100%, 100%, 100%, 100%, 49%, 50%.

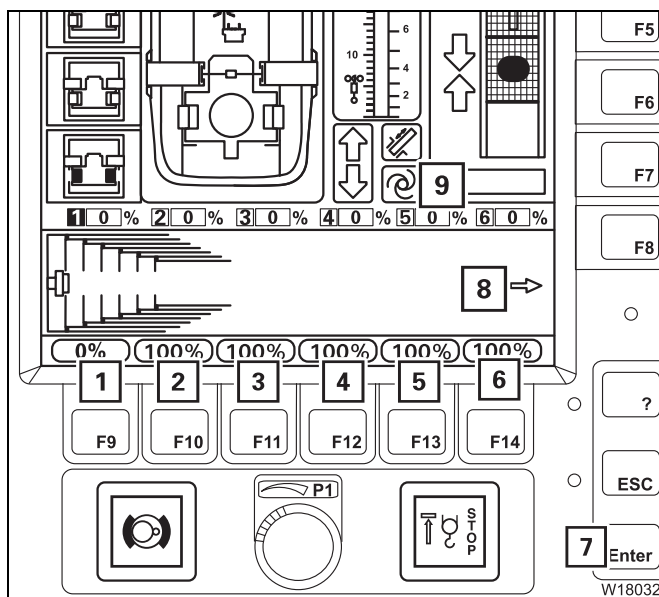

### Confirming the entry

- Press the button (7) once:
  - Values (1) to (6) are **red** – telescoping **not permissible** – teleautomation off.
  - Values (1) are (6) are **green** – display of symbol (9) – teleautomation on.

### Telescoping

- Move the control lever for the displayed telescope direction (8), e.g. for extending.



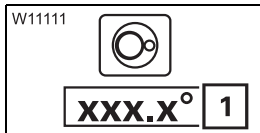

### Reading off the slewing angle

In the *Slewing gear/houselock* submenu – display (1) shows the current position.

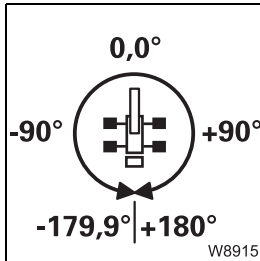

0° means that the superstructure is slewed to the rear.

- Angles in the **right semi-circle** are displayed as **positive** values (0° to +180.0°).
- Angles in the **left semi-circle** are displayed as **negative** values (0° to -179.9°).

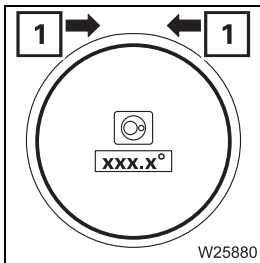

### Slewing to 0° or 180°

The displays (1) are activated in a range of  $\pm 20^\circ$  from the superstructure positions 0° and 180°.

- If both arrows illuminate, the 0° or 180° superstructure position has been reached.
- If one arrow illuminates, it indicates the slewing direction that is required to reach the 0° or 180° superstructure position.

### Braking the slewing movement



#### Risk of the main boom buckling!

Do not under any circumstances switch off the slewing gear to brake it. Only switch off the slewing gear after the superstructure has stopped turning.

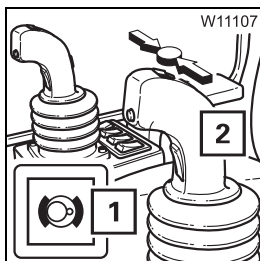

- Move the control lever (2) towards its initial position – the slewing movement will be braked.

At the initial position, the slewing movement will be stopped. At the same time the slewing gear brake will be applied, and lamp (1) will light up.



## 11.4.8 Displaying the operating hours

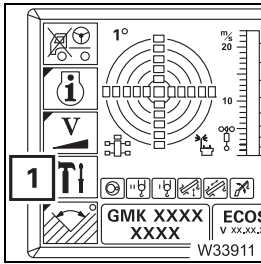

- In the main menu press button (1) once.  
This opens the *Settings* submenu.

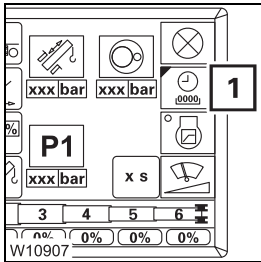

- Press the button (1) once.  
The *Operating hours* submenu opens.

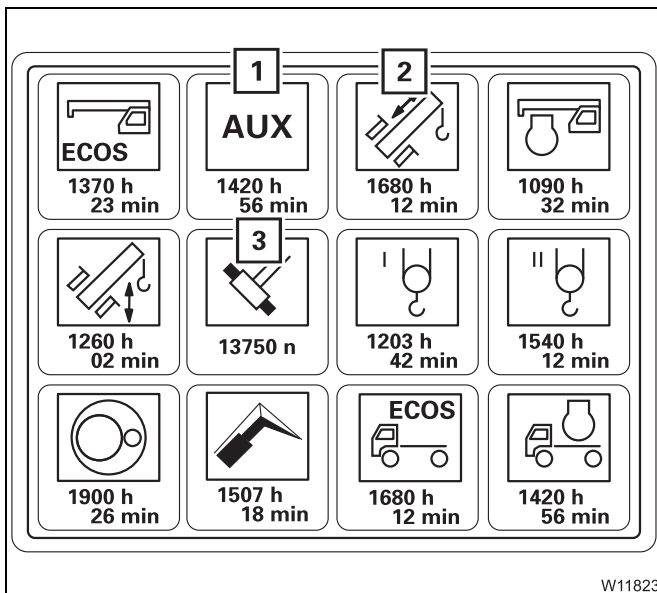

The operating hours are displayed below the symbols, e.g. 1,680 hours and 12 minutes for the telescoping mechanism (2).

**Exception:** The value below the symbol (3) indicates how often the cycle *Unlock telescopic section* has been performed, e.g. 13,750 times.

Auxiliary power units (1) include:

- Counterweight hoist unit,
- Crane cab inclination.

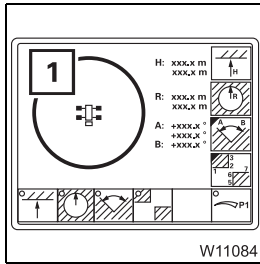

The limit value for the working radius affects the representation of defined objects.  
Only points that are within the limit value (1) will be displayed.

### Slewing angle

Slewing angles are entered in a submenu.

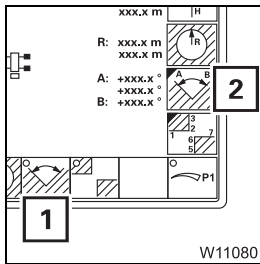

Before entering values, monitoring (1) must be switched off – dot **black**;  
▶▶▶ p. 11 - 126.

- Press the button (2) once.  
The *Enter slewing angle* submenu opens.

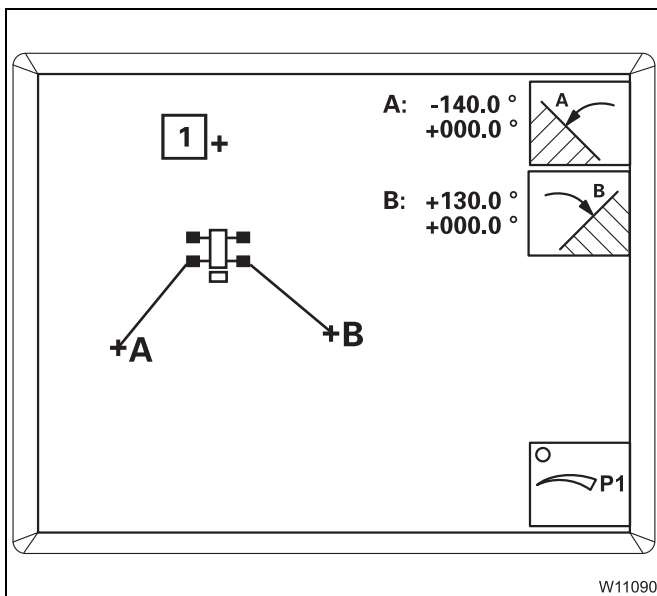

### Display of the slewing angles

The cross (1) shows the current position of the main boom.

- The slewing angle **A** limits slewing to the left.
- The slewing angle **B** limits slewing to the right.

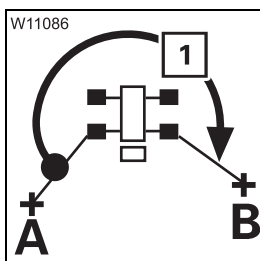

The permissible slewing range is represented by the angle going clockwise from **A** to **B**.  
Approx. 270° in this illustration – arrow (1).



## 11.6

## Work break

### 11.6.1

### In case of short work breaks



#### **Risk of accidents due to suspended loads!**

Never switch off the engine whilst a load is suspended. You must have the control levers at hand in order to intervene at any time.  
Always set down the load before you leave the crane cab.

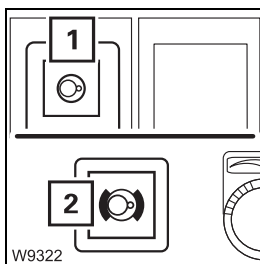

- Switch off the slewing gear.
  - The lamp in the (1) button must be dimly lit.
  - Lamp (2) must light up – slewing gear brake applied.

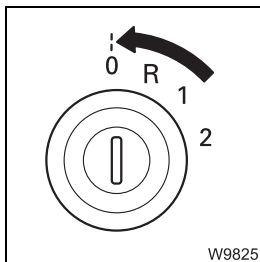

Switch the engine off, turn the ignition key to position **0** and remove it.

Ensure that no unauthorised persons can operate the truck crane;

➡ *To secure the truck crane, p. 11 - 130.*

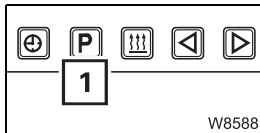

- To retrieve a storage location, press the button (1) once.



The following flash:

- The retrieved storage location, e. g. 2
- The last saved heating start, e.g. 06:00.

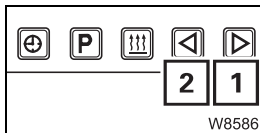

- Set the time for the desired heating start – button (1) or (2), e.g. 08:00.



Wait for approx. 5 seconds until the weekday for the heating start flashes, e.g. **MO** for Monday.

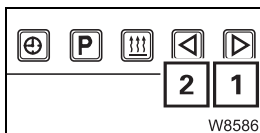

- Set the weekday for the desired heating start – button (1) or (2).

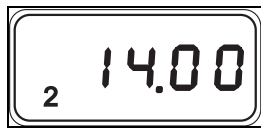

Wait for approx. 5 seconds until the current time is displayed, e. g. 14.00. Now, the new heating start has been saved and switched on.



If you wish to store one or two more heating starts, retrieve a new storage location using the button (1) and repeat the procedure.

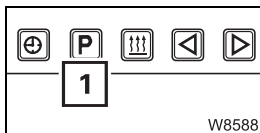

After you have saved the heating start, you can also set the heating period;  p. 11 - 139.

### Setting the heating period

After an automatic start, the heating system will switch off automatically as soon as the set heating period has elapsed.

The heating period applies to all saved heating starts.

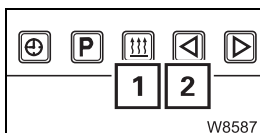

- Switch off the heating system using the button (1).
- Press the button (2) for longer than 3 seconds.



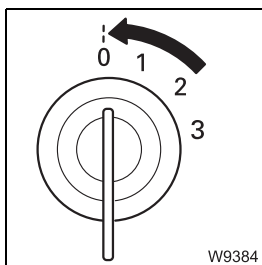

9. Turn off the engine for driving; *Switch the engine off*, p. 4 - 23.

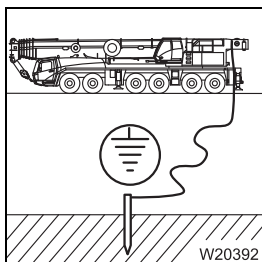

10. Earth the truck crane, if necessary; *Earthing the truck crane*, p. 12 - 13.

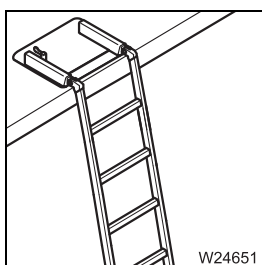

11. Fold out **all** ladders; , p. 4 - 6.

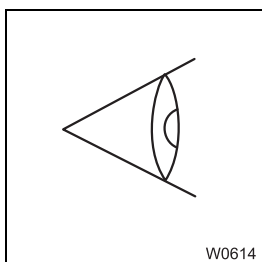

12. Inspect the truck crane, while looking out in particular for any leaking fluids (oil, fuel or water).

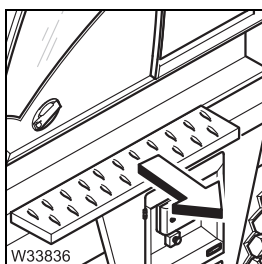

13. Extend step; *Extendable step*, p. 12 - 122.

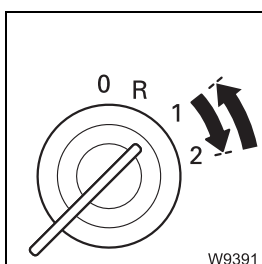

14. Start the engine for crane operation; p. 10 - 12.



### 12.2.3

## Earthing the truck crane

The truck crane may become charged with static electricity. This may occur especially when using outrigger pads made of plastic or when the outrigger pads are packed with insulating material (e.g. wooden planks).

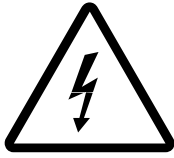

#### Risk of accidents due to electric shock!

Earth the truck crane before you start to work with it

- near strong transmitters (radio transmitters, radio stations, etc.),
- near high-frequency switchgear substations,
- if a thunderstorm is forecast.

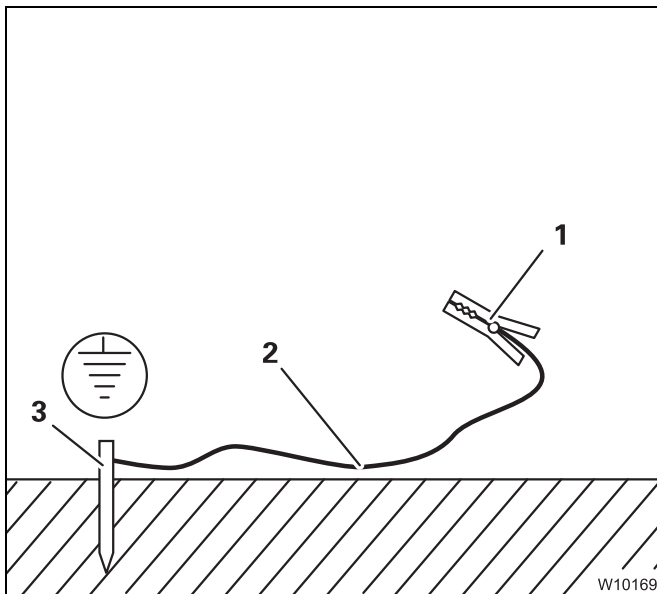

Use electrically conducting material for earthing.

- Hammer a metal rod (3) (length approx. 2.0 m ) at least 1.5 m into the ground.
- For better conductivity, dampen the soil around the metal rod (3).
- Clamp an insulated cable (2) to the metal rod (3) (cross-section of at least 16 mm<sup>2</sup>).
- Connect the free end of the cable using a clamp (1).



#### Risk of accidents due to electric shock!

Ensure that the connections between the cable and the clamp are electrically conductive.

Do not attach the clamp to parts that are bolted on, such as valves, cover plates or similar parts.

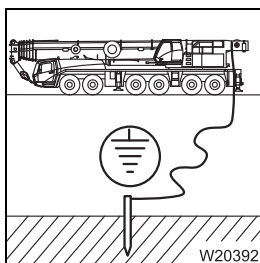

- Attach the clamp to the main boom or to the superstructure.

## 12.5

### Starting the engine for driving for rigging work

The engine for driving must be running for rigging work, e.g., to move the outriggers. You can start the engine for driving:

- From the crane cab,
- From the control units of the outriggers.



You can generally start the engine only if a bridging plug is inserted in all sockets not required.

### 12.5.1

#### Starting/turning off the engine from the crane cab

##### Prerequisites

The following requirements must be met before you can start the engine for driving from the driver's cab:

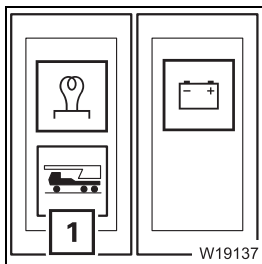

- The hand-held control must be disconnected and bridging plugs plugged into all the sockets.
- The carrier ignition is switched off and the ignition key is removed. The lamp (1) in the crane cab has gone out.
- The superstructure ignition has been switched on for approx. 30 seconds.

The engine for crane operation can be switched on or off.

##### Starting the engine

All activities and checks required to start the engine must be carried out before starting the engine; p. 4 - 1.

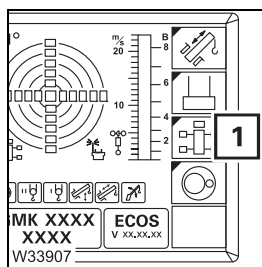

- In the main menu press button (1) once.  
The *Outriggers* submenu opens.



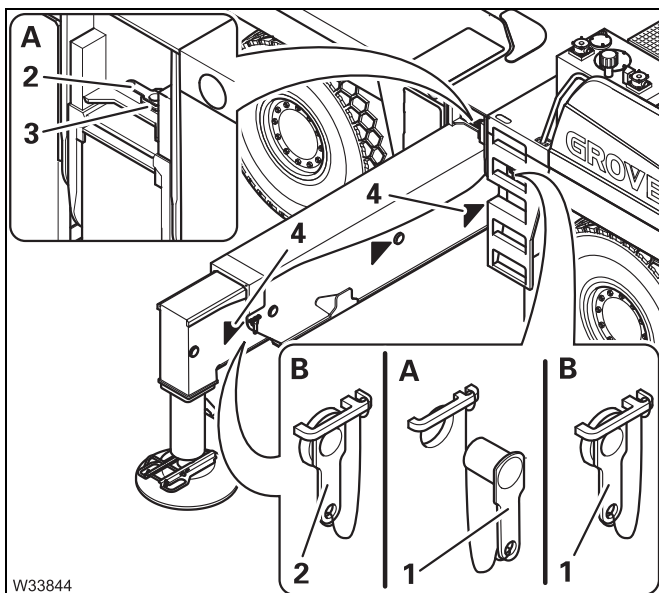

W33844

### Outrigger span 8.70 x 7.40 m

#### (A) – Prerequisites

- Pin (1) must be removed
- Pin (2) inserted in holder (3)

#### (B) – Setting and securing

- Extend the outrigger beam up to the mark (4).
- Secure the outrigger beam with the pins (1) and (2).
- Set the outrigger spans on the other outrigger beams in the same way.

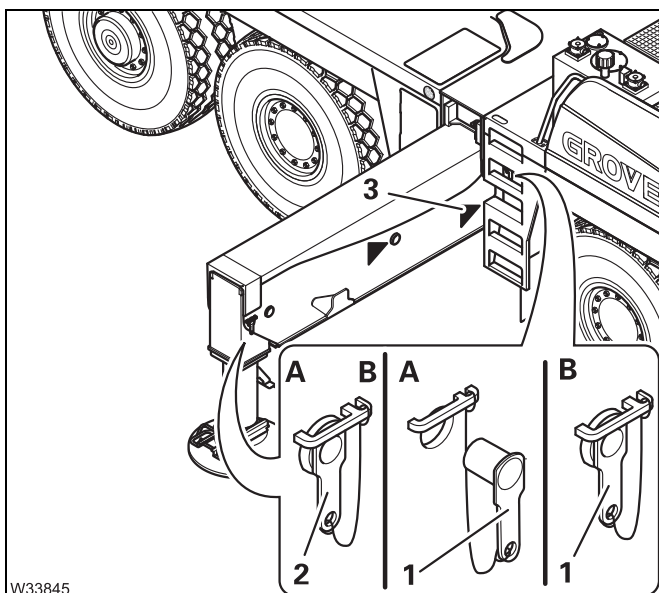

W33845

### Outrigger span 8.70 x 6.30 m

#### (A) – Prerequisites

- Pin (1) must be removed
- Pin (2) must be inserted

#### (B) – Setting and securing

- Extend the outrigger beam up to the mark (3).
- Secure the outrigger beam with the pin (1).
- The pin (2) remains inserted.
- Set the outrigger spans on the other outrigger beams in the same way.



## From the crane cab

The following operating elements are found in the *Outriggers* submenu.

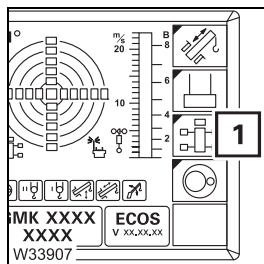

### Opening the submenu

- In the main menu, press button (1) once.  
The *Outriggers* submenu opens.

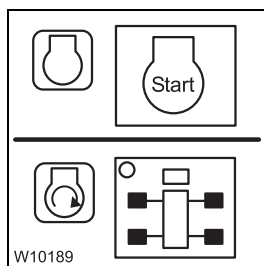

### Start the engine

- Switch the carrier ignition on and start the engine for driving;  
▮▮▮▮ p. 12 - 23.
- Switch off the slewing gear.

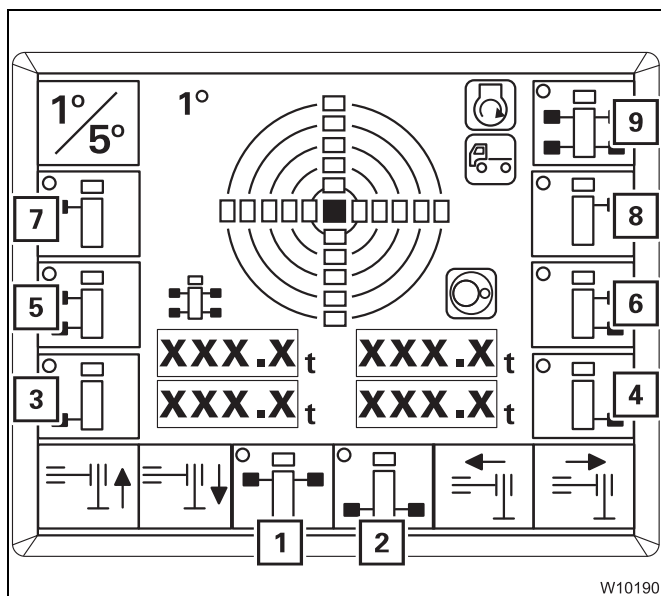

### Pre-selecting outriggers

- Press the button once next to the symbol for the desired outrigger.

- 1 Both at front
- 2 Both at rear
- 3 Rear left
- 4 Rear right
- 5 Both on left
- 6 Both on right
- 7 Front left
- 8 Front right
- 9 All

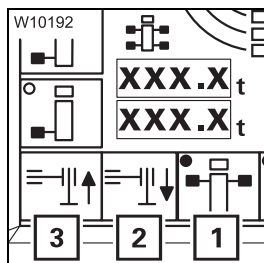

Pre-selection is switched on.

- The dot in the symbol turns **green**, e.g. in symbol (1).
- The symbols (2) and (3) turn **black**.

The pre-selection is switched off after approx. 10 seconds.



## 12.7

### Rigging/unrigging the counterweight

Depending on the version, the GMK6300L can be equipped with a counterweight mass of 7.0 t to 92.5 t.

#### 12.7.1

#### Counterweight sections

There are various counterweight sections, depending on the truck crane's version and additional equipment.

The counterweight combinations can be comprised of:

##### Version A

In this version, the counterweight must be completely unrigged when driving with axle loads of a maximum 12 t

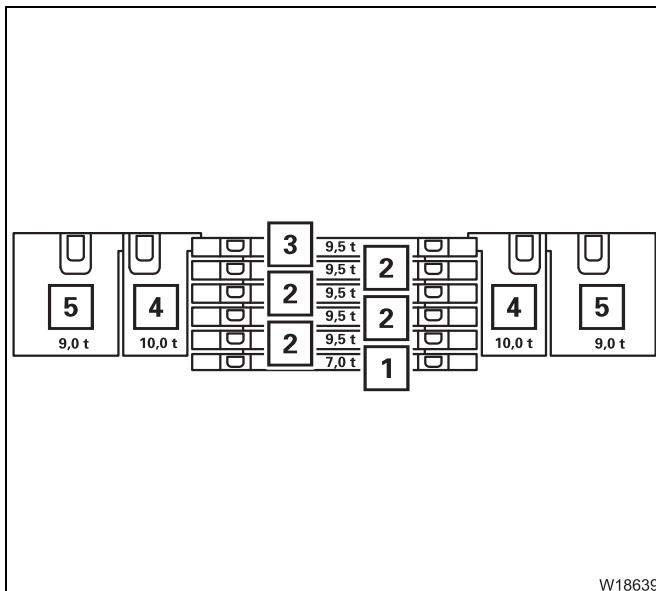

- one 7.0 t base plate (1)
- four 9.5 t counterweight sections (2)
- one 9.5 t counterweight section (3), with the cutouts and recesses

The counterweight section (3) must always be placed on top with the 54.5 t counterweight combination.

- two 10.0 t counterweight blocks<sup>1)</sup> (4)
- two 9.0 t counterweight blocks<sup>1)</sup> (5)

<sup>1)</sup> Additional equipment



In counterweight combinations from 54.5 t, the counterweight section (3) must always be on top.



**Combinations for the basic equipment in version A**

The following counterweight combinations can be combined on the counterweight platform.



**Risk of accident due to an incorrect counterweight mass!**

Only combine the counterweights in such a manner that the counterweight mass corresponds to the specifications in this section and in the *Lifting capacity table*. Other combinations are not permitted.

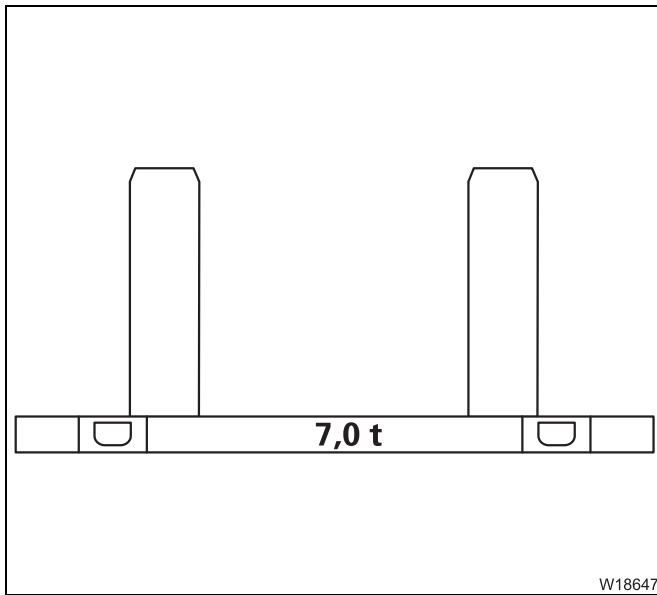

**7.0 t**

– 7 t base plate

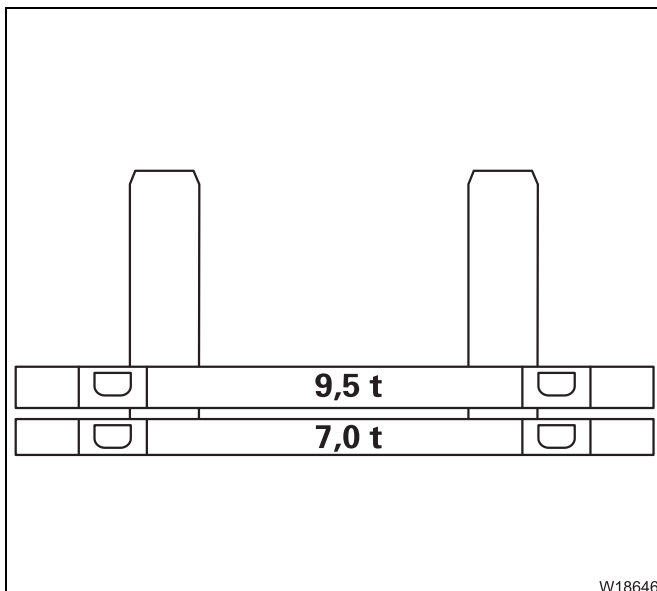

**16.5 t**

– 7 t base plate

– 9.5 t section



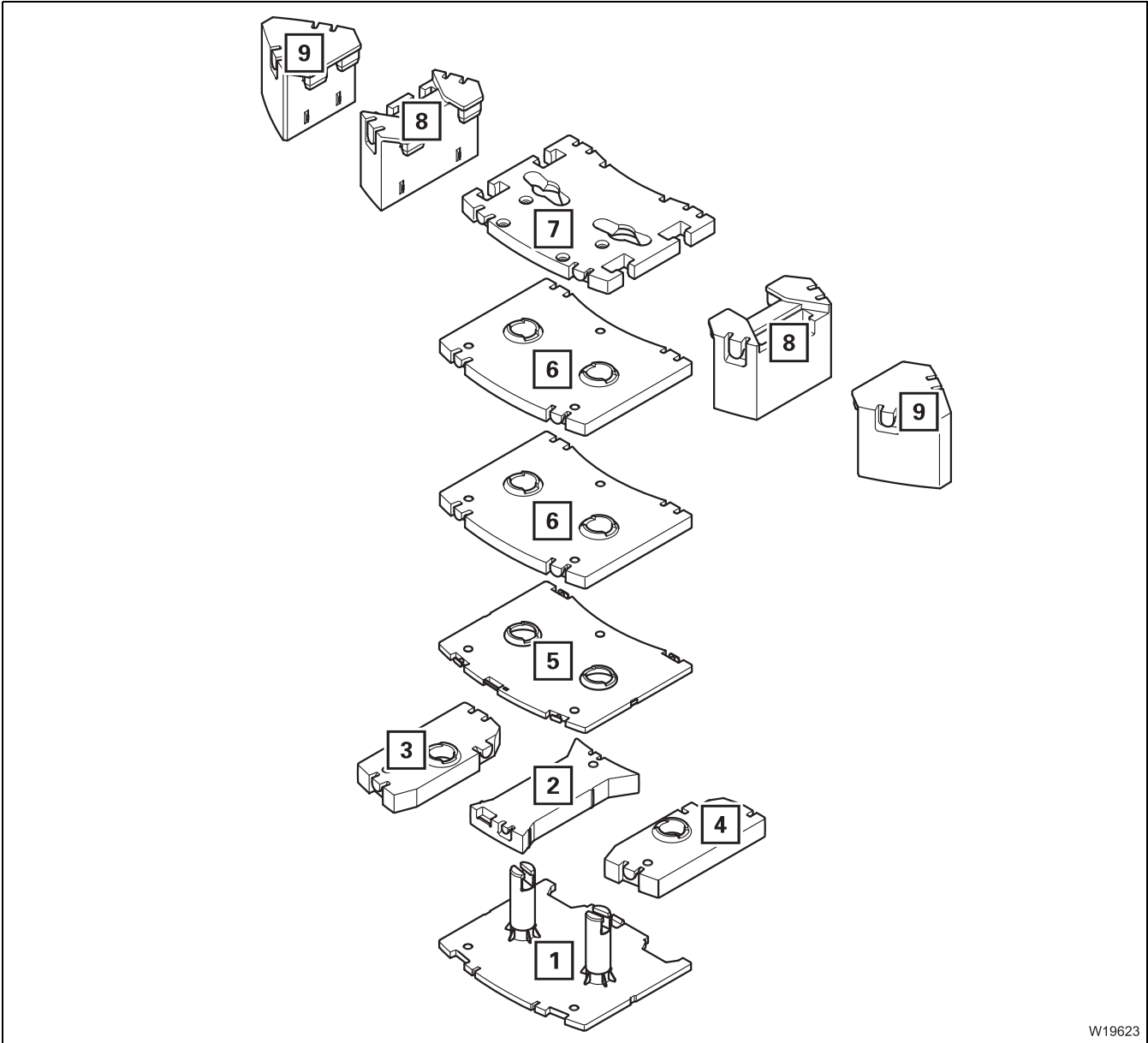

W19623

## 12.7.9

### Slewing with rigged counterweight

You may only slew the superstructure with a rigged counterweight if the truck crane is supported by a sufficient outrigger span and the permissible working radii are observed. Otherwise the truck crane will overturn during slewing.

The current rigging mode is registered by the RCL code set, and the RCL disables the slewing operation if it is not permitted.



#### **Danger of overturning when slewing with an incorrectly set RCL!**

The RCL only disables the slewing operation if you have entered the RCL code correctly and if the RCL is not overridden. Therefore always check before slewing whether the RCL code valid for the current rigging mode is displayed. This prevents slewing operations being released within impermissible ranges and the truck crane from overturning.



#### **Danger of overturning when slewing with the hand-held control!**

Crane operations are not monitored by the RCL whilst the hand-held control is connected! Always check whether a sufficient outrigger span has been set for the rigged counterweight before slewing. This prevents the truck crane from overturning during slewing due to excess counterweight mass.

The following table specifies (depending on the counterweight and outrigger span) whether slewing the superstructure is:

- Permitted
- Only permitted for certain working radii
- Disabled (with the correct rigging mode).



## Reeving the hoist rope



### Danger due to slack rope!

Only use hook blocks and sling gear of the minimum weight prescribed in the *Lifting capacity table*, depending on the reeving and boom length. This prevents slack rope forming at large heights when lifting without a load. This can result in the load slipping.

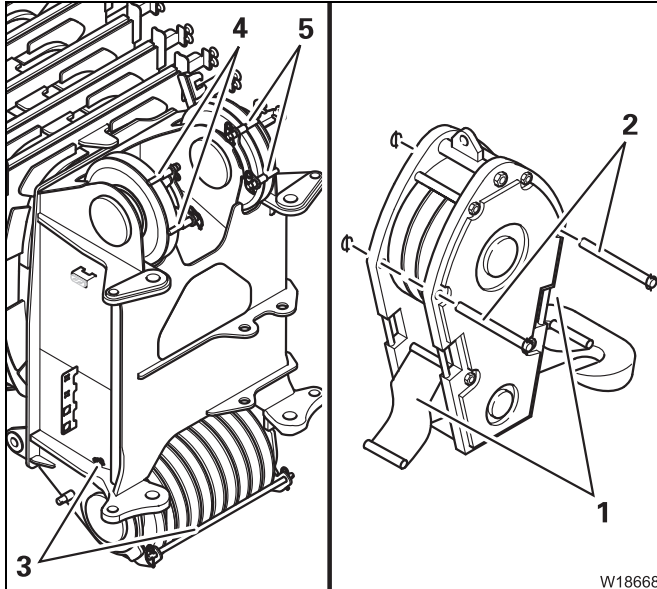

### Opening the hook block

- Pull out the rods (2).
- Fold down the plates (1).

### Fitting the hoist rope

- Pull out the rods (3).
- Pull out the rod (4) for the **main hoist rope**.
- Pull out the rod (5) for the **auxiliary hoist rope**.

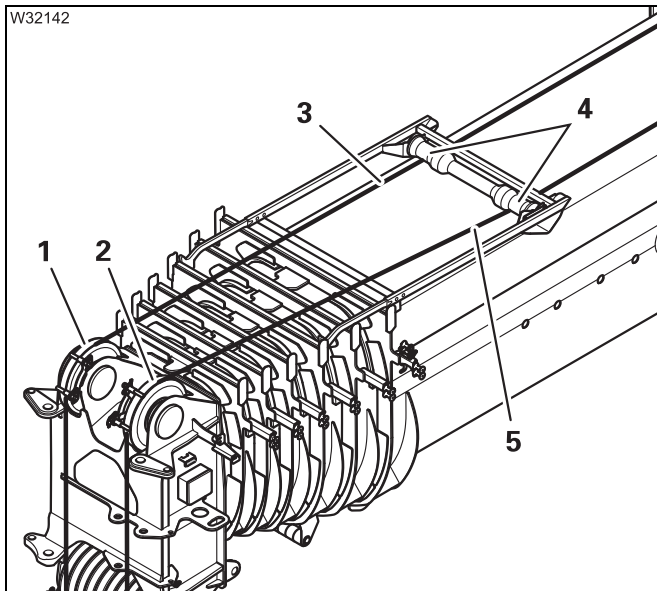

- Feed the main hoist rope (3) through under the sheave (4).
- Feed the auxiliary hoist rope (5) through under the sheave (4).

- Feed the main hoist rope (3) to the head sheave (1).
- Feed the auxiliary hoist rope (5) to the head sheave (2).



Feed the hoist rope through under the sheave (4) also when working with the lattice extension.



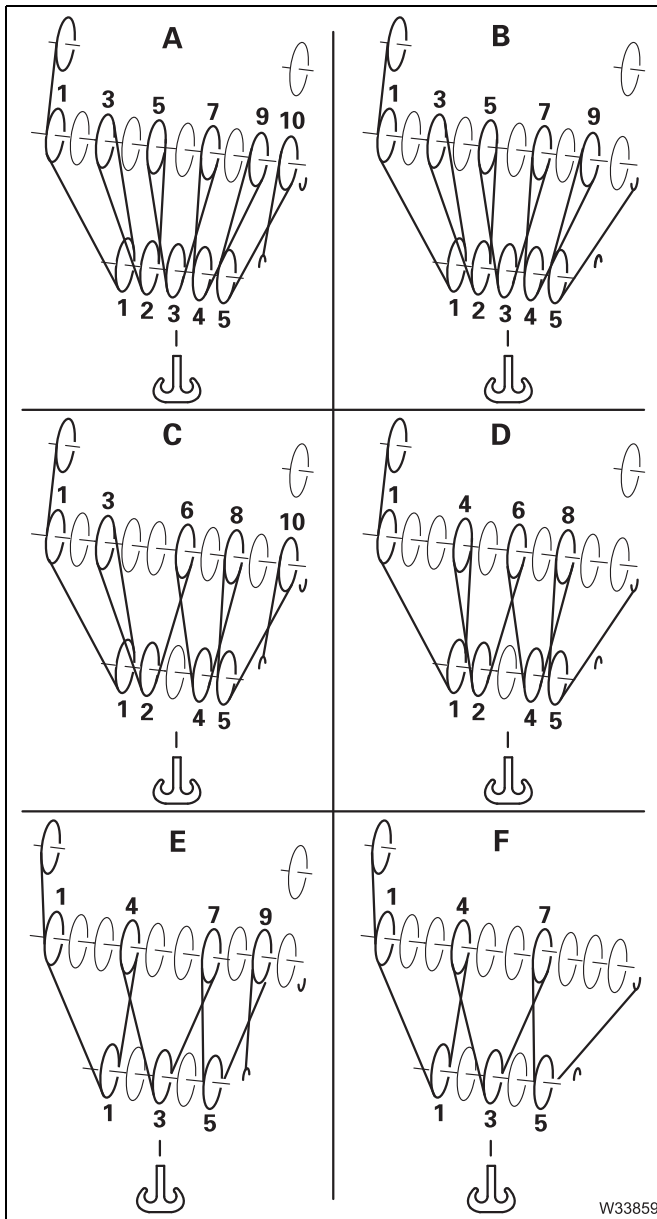

**5-sheave hook block**

Reeving

- A** 11x
- B** 10x
- C** 9x
- D** 8x
- E** 7x
- F** 6x



W33859

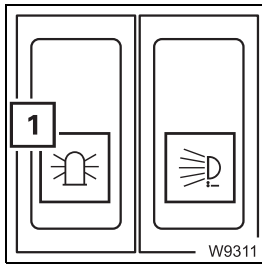

Switching the air traffic control light on and off:

**To switch on:** Press in switch (1) at the bottom

**To switch off:** Press in switch (1) at the top

### Removing

You must remove the rod with the anemometer/air traffic control light before driving on the road; ►► p. 12 - 112.

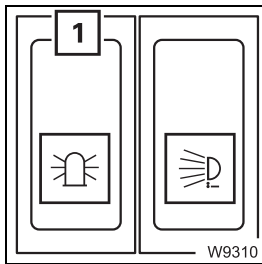

- Switch off the air traffic control light – press the switch (1) upwards and inwards.

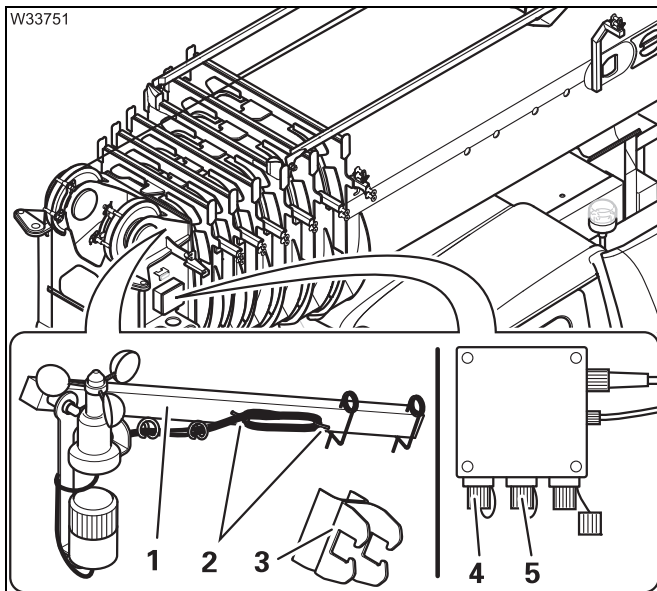

- Remove the plug and close the sockets (4) and (5) with the protective caps.
- Wind the cables on to the holder (2).
- Remove the rod (1) from the holder (3).
- For transportation, fasten the retaining pins to the rod (1).

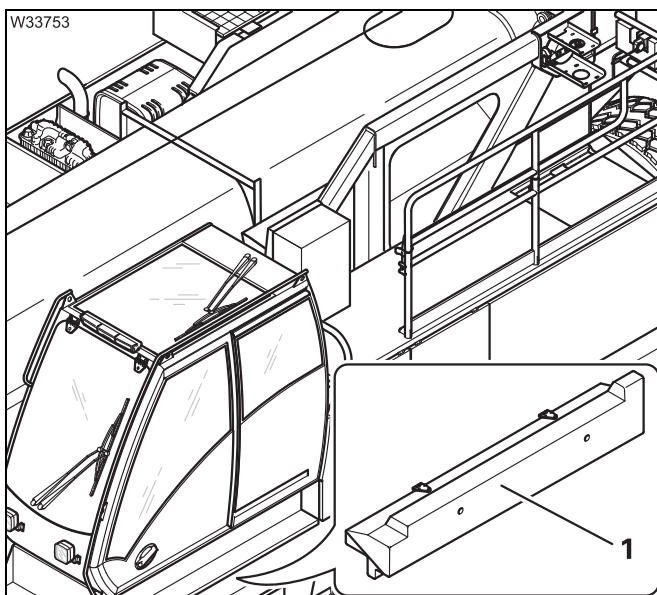

- If necessary, store the rod in the storage compartment (1).

## 12.9.5

### Folding the mirrors in and out, and adjusting them

The mirror must be folded in for driving. You must fold the mirror out and adjust it for crane operation or driving from the superstructure.



#### **Risk of accidents due to exceeding the permissible dimensions!**

Fold the mirror in for driving. The overall width specified for on-road driving is exceeded if the mirror is folded out.

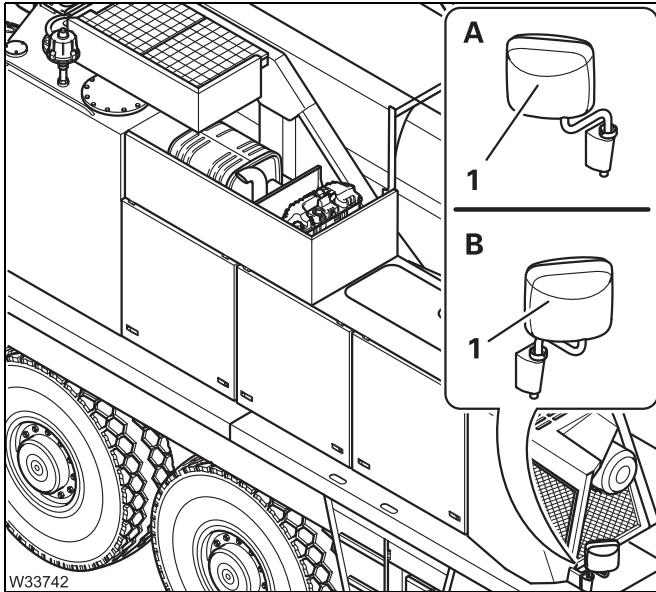

#### **(A) – Folding out and adjusting the mirror**

- Fold out the mirror (1).
- Adjust the mirror (1) such that the rear right outrigger beam can be observed clearly from the crane cab (when the main boom is raised).

#### **(B) – Folding in the mirror**

- Fold in the mirror (1) until it does not protrude over the side of the carrier.

### 13.3.4

## Gears/connections

### Transmission

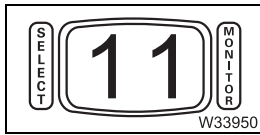

- Select gear **1** as the top gear to prevent the transmission from shifting gears; p. 5 - 32.

### Connections

If required, you can

- switch on the longitudinal differential locks; p. 5 - 62,
- switch on the transverse differential locks; p. 5 - 62,
- switch on separate steering; p. 5 - 71.

## 13.4

## Whilst driving

- Drive only at the lowest possible speed, **max. 1.5 km/h**
- The turning radius should be as great as possible when driving around corners!
- Steer the truck crane when it is moving, and avoid sudden changes to the steering!



### **Risk of damage to the steering linkage!**

The steering linkage can be damaged if the steering wheel is moved while the vehicle is stationary.



### **Risk of damage to the axle lines!**

The suspension struts could be damaged if the maximum permissible operation pressure in the suspension is exceeded.  
Always monitor the operation pressure in the suspension when moving the rigged truck crane.



# 14

## Malfunctions during crane operation

### 14.1

### Emergency stop switch



#### **Risk of overloading if used improperly!**

Press the emergency stop switch only if it is no longer possible to stop the crane movements with the normal operating elements.

The emergency stop switch stops the crane movements suddenly. This may overload the truck crane, e.g. in the event of high working speeds and large working radii.

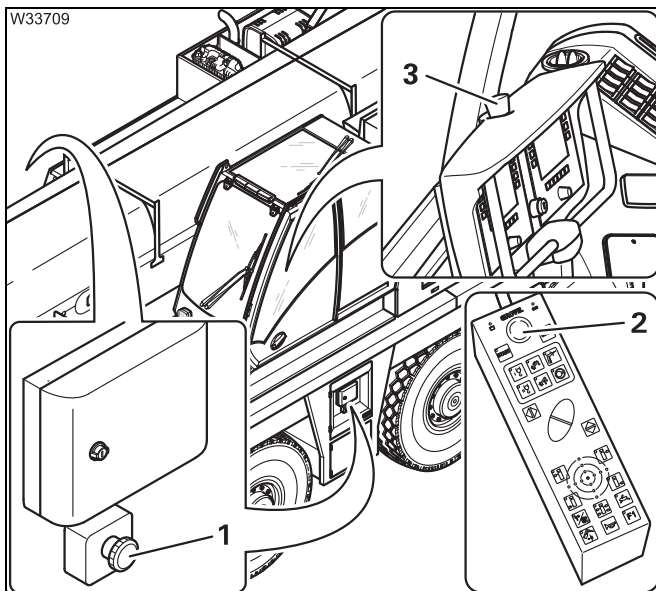

- Stop all crane movements.

Four emergency stop switches are provided for emergencies:

- 1 On the carrier
- 2 On the hand-held control
- 3 In the crane cab

- Press an emergency stop switch (1), (2) or (3). The switch latches.

The engine shuts down.

After activating an emergency stop switch;

▣▣▣▣ *Resetting the emergency stop switch, p. 4 - 24.*



The battery master switch cannot be used as an emergency stop switch for the engine. The engine continues to run after the battery master switch has been switched off.

### 14.3.3

## Fuses in the battery box

Fuses F10 to F13 are contained in the battery box.

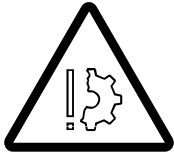

#### **Danger from lead and lead compounds on batteries!**

Battery poles, battery terminals and parts of the battery itself contain lead and lead compounds. Wash your hands after working on these parts or in these areas!

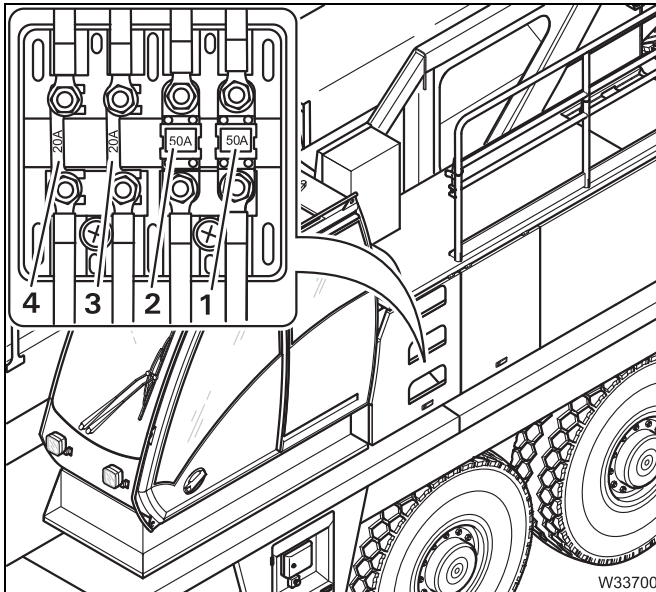

- Open the battery box.

The fuses are in a terminal box on the right side next to the batteries.

- Remove the lid from the terminal box:

- 1 Fuse F10
- 2 Fuse F11
- 3 Fuse F12
- 4 Fuse F13

- Observe the instructions on changing fuses; p. 14 - 5.

Designation	Amperage (A)	Function
F10	50	Unassigned
F11	50	Superstructure central fuse
F12	20	Unassigned
F13	20	Preliminary fuse for time switch of auxiliary heater

## 14.4.8 Malfunctions in the slewing gear

Malfunction	Cause	Remedy
<b>Slewing gear not functioning</b>	Slewing gear off, lamp in button lights up dimly	Switch on the slewing gear; ▣▣▣▣ p. 11 - 97
	Houselock switched on	▣▣▣▣ <i>Switching the houselock on/off</i> , p. 11 - 15
	Turntable locked	▣▣▣▣ p. 11 - 14
	Dead man's switch system not actuated.	Press dead man's switch
	Emergency stop switch engaged	▣▣▣▣ <i>Resetting the emergency stop switch</i> , p. 4 - 24
	Fuses F1/1, F1/2, F3/1, F3/2, F3/5, F3/6 blown	Replace the blown fuse; ▣▣▣▣ p. 14 - 5
	Fuse blown on circuit board	Replace the blown fuse; ▣▣▣▣ p. 14 - 7
	Control unit faulty, error message is displayed	Acknowledge error message once; ▣▣▣▣ p. 14 - 36 – if error persists, notify <b>Manitowoc Crane Care</b>
	Fuse RCL F6 faulty	Replace the blown fuse; ▣▣▣▣ p. 14 - 12
	Fuse F3/3 blown	Replace the blown fuse; ▣▣▣▣ p. 14 - 9
 In the <i>Slewing gear</i> submenu, the symbol <i>Auxiliary hoist lock display</i> lights up.	Mechanically lock the auxiliary hoist correctly; ▣▣▣▣ <i>Extending the locking cylinders</i> , p. 6 - 99	
<b>Slewing function not working</b>	Enter RCL code for the <i>0° to the rear</i> position	Enter RCL code for a slewing range
	Counterweight lifting cylinder not fully retracted	Fully retract lifting cylinder; ▣▣▣▣ p. 12 - 76
	Function disabled by ECOS	If necessary, acknowledge error once and briefly turn off the ignition – if error persists, notify <b>Manitowoc Crane Care</b>



**Table of error codes**

The following table contains a number of error codes, their causes and possible remedies.

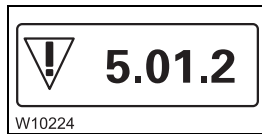

An error code consists, from left to right, of a one-digit number (e. g. **5**), a two-digit number (e.g. **01**) and a one-digit number (e.g. **2**).

- Check whether the table contains the displayed error code. If the information in the table does not help resolve the error, note the error code(s) and contact **Manitowoc Crane Care**.

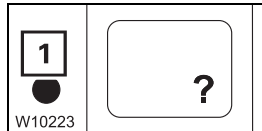

When all errors are remedied, the lamp (1) goes out.

Error code			Cause	Remedy
1	01	1 - 7	Error pressure sensor 1, Lower chamber	Switch off pressure sensor 1;  p. 14 - 34
1	01	8	Pressure sensor 1 switched off	Have malfunction corrected
1	02	1 - 7	Error pressure sensor 2, Lower chamber	Switch off pressure sensor 2;  p. 14 - 34
1	02	8	Pressure sensor 2 switched off	Have malfunction corrected
1	04	1 - 7	Error angle sensor 1, Main boom	Switch off pressure sensor 1;  p. 14 - 34
1	04	8	Angle sensor 1 switched off	Have malfunction corrected
1	05	1 - 7	Error angle sensor 2, Main boom	Switch off pressure sensor 2;  p. 14 - 34
1	05	8	Angle sensor 2 switched off	Have malfunction corrected
1	13 to 21	1	Lattice extension not connected or sensor faulty	Electrically connect lattice extension; if error persists, notify <b>Manitowoc Crane Care</b>



## 14.5

### Emergency operations and programs

This section contains all the information about possible emergency operations and emergency programs. The following are available:

- mechanical emergency activation for retracting,
- *Telescoping emergency program* submenu,
- entering the telescoping after an emergency operation and
- operation of the power units with the hand-held control.

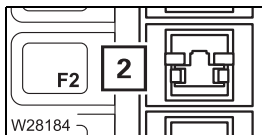

### Retracting and locking a telescopic section

During telescoping you may **not** select Lock. Under **no** circumstances should you press the button (2).



#### Risk of damage to the main boom!

If you select Lock during telescoping, the locking pins on the telescopic section are slid out immediately and they can damage or tear the electrical or hydraulic components in the main boom.

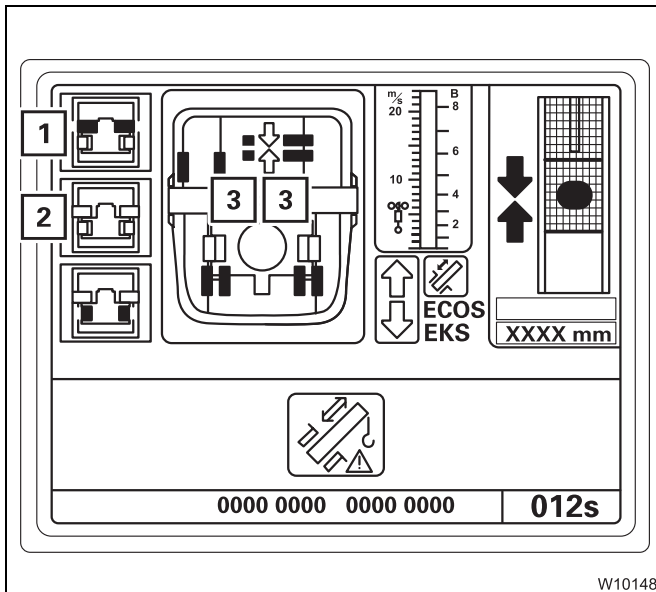

- Retract the telescopic section slowly and as far as possible.
- Press the button (2) once.
- Extend to approx. 35 mm .

The telescopic section is now locked. In *Locked* position:

- the locking pins (3) are **green**,
- the symbol (1) is **grey**,
- the symbol (2) is **yellow**.
- Set down the telescopic section and retract it as far as it will go.

### Unlocking the telescoping cylinder

If the telescopic section is locked, you can now unlock the telescoping cylinder.



#### Risk of accidents from sudden retraction of a telescopic section!

Press the  button for unlocking the telescopic section **not more than twice**. If this does not start the unlocking procedure, contact **Manitowoc Crane Care**.

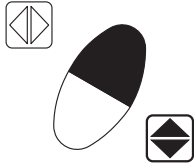
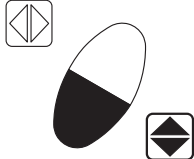
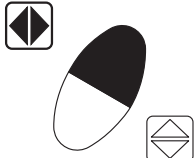
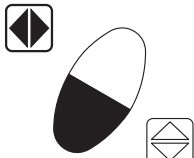

The following table shows all the button combinations. Engaged buttons are shown in black.

Button combination	Pre-selected power unit				
	Telescoping mechanism	Derricking gear	Slewing gear	Hoists	Lattice extension
 W3851	None <sup>1)</sup>	Lower boom	None	Lower	Lower boom
 W3850	Retract	Raise boom	None	Lift	Raise boom
 W3849	None	None	Slew to the right	None	None
 W3848	None	None	Slew to left	None	None

<sup>1)</sup> If the telescoping cylinder is unlocked, it will extend.



**For lifting/  
lowering**

After establishing hydraulic circuits, switch one additional valve to continuous operation.

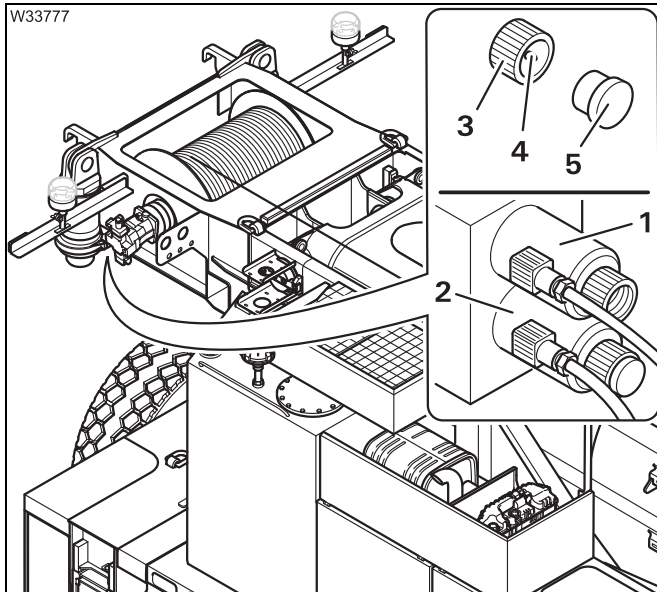

**Switching on continuous operation**

Always switch only **one** valve to continuous operation.

- 1 Valve Y1104 – Lowering **or**
- 2 Valve Y1105 – Lifting

- Unscrew the cap (3), e.g. from the valve (1).
- Remove the plug (5).
- Screw the cap and pin (4) on to the valve – continuous operation is now switched on.



**Danger due to falling loads!**

Switch off continuous operation immediately after the emergency activation.

Check whether the pins can be seen on both caps.

In this way, you can prevent loads falling immediately after being lifted during subsequent crane operations.

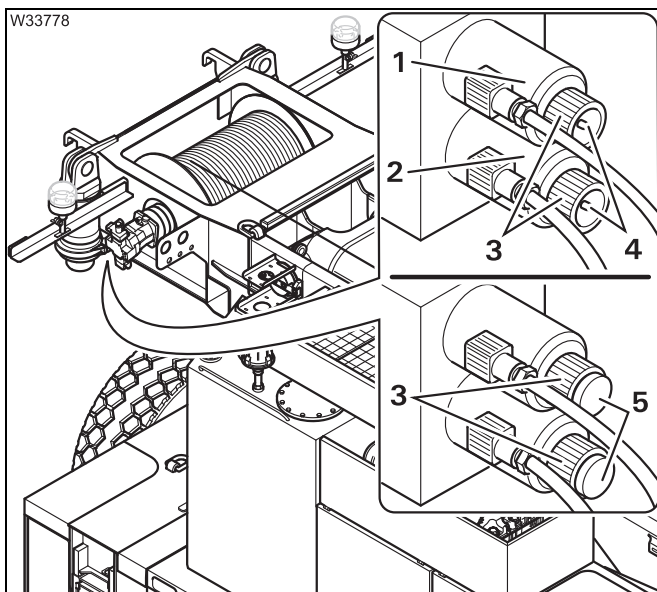

**Switching off continuous operation**

- Remove the cap (3) from the actuated valve (1), (2).
- Screw the cap on so that the pin (4) can be seen.
- Insert the plug (5).



**15      Index**

Malfunctions	7 - 27
Operation in the driver's cab	
Checking after starting	4 - 18
Checking the fuel level	4 - 7
Checks before starting	4 - 10
Lamp test / switching state alignment	4 - 12
monitoring elements	4 - 20
Resetting the emergency stop switch	4 - 24
Setting idling speed	4 - 22
Starting	4 - 15
Starting - CHECKLIST	4 - 1
Switch on the ignition	4 - 11
switching off	4 - 23
preheating	5 - 80
procedure during malfunctions	7 - 39, 7 - 40
Refuel	4 - 7
Starting from the crane cab - for rigging work	12 - 23
Starting/switching off from the outrigger control units - for rigging work	12 - 26
<b>F</b> Final drive	
Operating elements in the driver's cab	3 - 53
Front flap	
Opening and closing	3 - 72
Fuel tank	
Engine for crane operation	10 - 4
Standard tank	4 - 7
Fuses	
on the carrier	7 - 19
on the superstructure	14 - 5
<b>H</b> Hand-held control	
Disconnecting	12 - 21
Malfunctions	14 - 24
Heating system	
Crane cab	
Auxiliary air heater	11 - 142
Auxiliary water heater	11 - 135
Standard heating system	11 - 131
Driver's cab	
Auxiliary water heater	5 - 80
Standard heating system	5 - 75
High-speed mode	11 - 94
Derricking gear/telescoping mechanism high-speed mode	11 - 94
High-speed mode for hoists	11 - 95
Switch on function	11 - 94

CLICK HERE TO **DOWNLOAD** THE COMPLETE MANUAL

- Thank you very much for reading the preview of the manual.
- You can download the complete manual from: [www.heydownloads.com](http://www.heydownloads.com) by clicking the link below



- Please note: If there is no response to CLICKING the link, please download this PDF first and then click on it.

CLICK HERE TO **DOWNLOAD** THE COMPLETE MANUAL