

# Operating Manual

## Part 1 – Driving

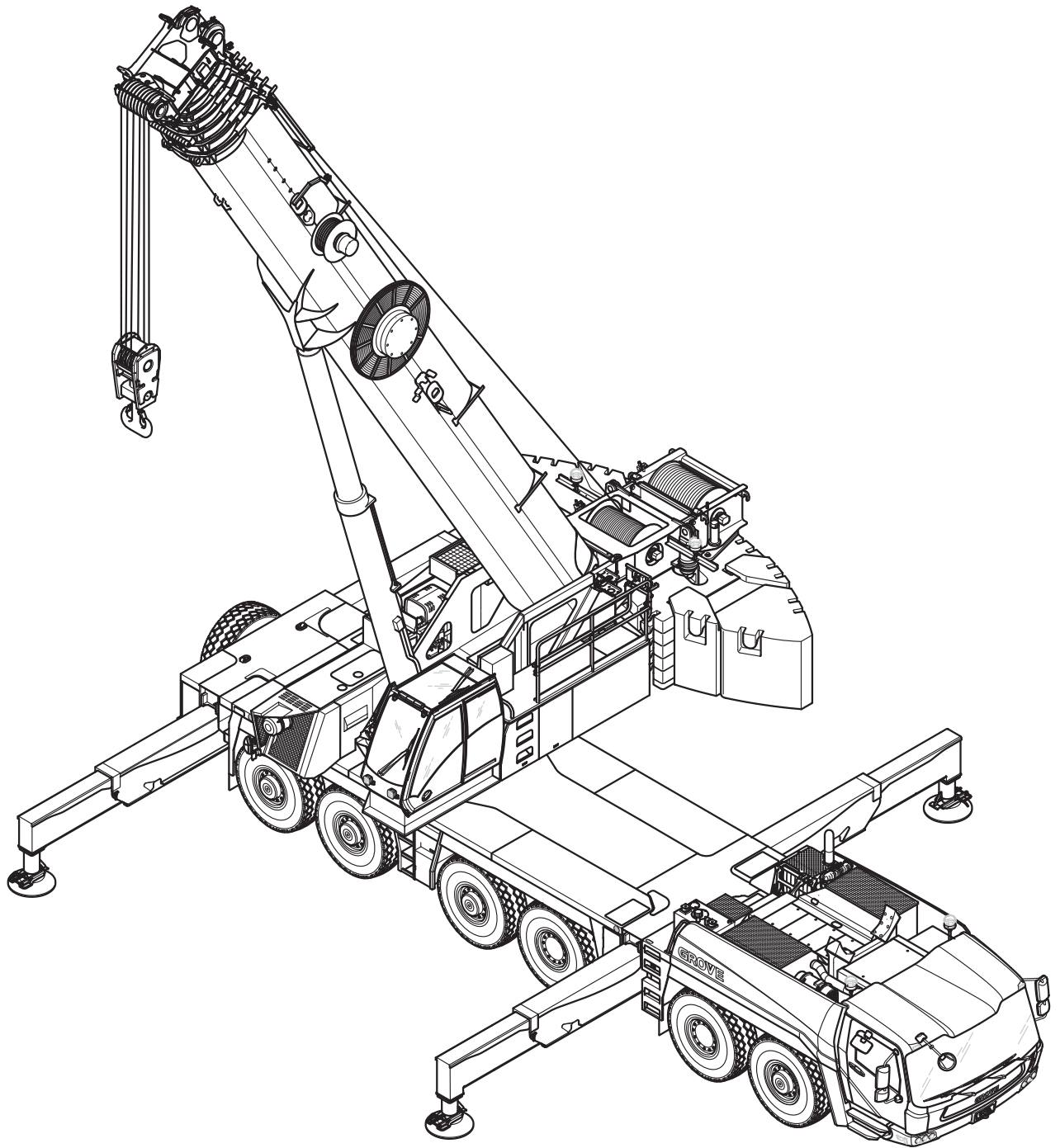

**3 302 740 en**

**14.03.2018**

CLICK HERE TO **DOWNLOAD** THE COMPLETE MANUAL

- Thank you very much for reading the preview of the manual.
- You can download the complete manual from: [www.heydownloads.com](http://www.heydownloads.com) by clicking the link below



- Please note: If there is no response to CLICKING the link, please download this PDF first and then click on it.

CLICK HERE TO **DOWNLOAD** THE COMPLETE MANUAL

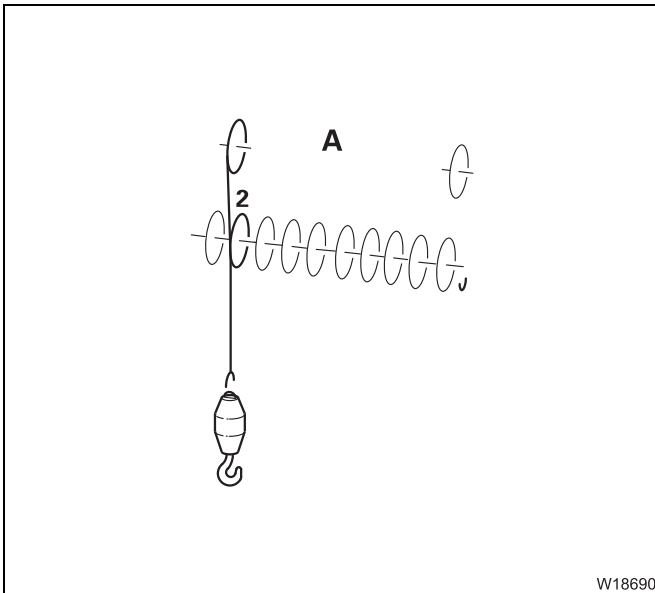

**Hook tackle**

Reeving

**A** 1x

## 1.2

## Branch offices

### 1.2.1

### Manitowoc Crane Care

If you need help or support with the operation on your truck crane, you can contact our branches at the following addresses **Manitowoc Crane Care**:

*<http://www.manitowoccranes.com>*

### 1.2.2

### Dealer list

Visit the following address for a global list of dealers:

*<http://www.manitowoccranes.com>*

## 1.3

## Warranty specifications

Please see the separately enclosed warranty certificate for information.

## 1.5.4

## Carrier

### Engine

Mercedes-Benz:	OM 473 LA
Engine emission: <sup>1)</sup> :	97/68/EG Level 4 (TIER 4 Final/Euromot 4)
Power <sup>1)</sup> :	430 kW (585 PS) at 1,700 rpm (ECE R 120)
DEF tank:	approx. 40 l
Fuel tank:	approx. 480 l

<sup>1)</sup> See also engine data card

### Transmission

Allison 4500 SP automatic transmission with integrated retarder<sup>1)</sup> with two driving programs, six forward gears and one reverse gear.

<sup>1)</sup> Additional equipment

### Transfer case

Kessler VG 2600, 2-stage

### Axle lines

#### Drive: 12 x 6 x 12

- 1. axle line: Steered and driven axle line
- 2. axle line: Steered axle line
- 3. axle line: Steered axle line, steering can be switched on
- 4. axle line: Steered and driven axle line, steering can be switched on
- 5. axle line: Steered and driven axle line
- 6. axle line: Steered axle line

#### Drive: 12 x 8 x 12

- 1. axle line: Steered and driven axle line
- 2. axle line: Steered axle line
- 3. axle line: Steered axle line, steering can be switched on
- 4. axle line: Steered and driven axle line, steering can be switched on
- 5. axle line: Steered and driven axle line, drive can be activated
- 6. axle line: Steered and driven axle line



## 1.7

### Notes on the operating manual

This operating manual is not a training manual for prospective crane operators! All descriptions have been written explicitly for crane operators who have been trained to operate truck cranes!

This operating manual is designed as a reference manual. It provides either a brief or a detailed explanation to the crane driver, based on his prior knowledge, of the individual operating steps and procedures.

### 1.7.1

#### What do the symbols used mean?

The following designations and symbols are used in the operating manual and in the maintenance manual to highlight particularly important information.

The vertical line to the left of the hazards and warnings indicates that: This text, regardless of its length, relates to the warning symbol.



This symbol indicates hazards related to the described operation, which can endanger persons. The type of danger (e.g. danger to life, risk of injury or risk of crushing) usually precedes the warning.



## 1.9

## Training – Information

For the EMEA (Europe, Middle East, Africa) area, **Manitowoc Crane Group Germany GmbH** offers comprehensive training for crane types GMK and GTK.

Our training centre is located in a maritime environment, on Germany's North Sea coast in Wilhelmshaven. It is there where we train our qualified service personnel and provide you, as the customer (or sales and marketing employee), with a training programme specific to your target group.

Knowledge of crane technology, components and systems used, crane functions and measures for the prevention of accidents that is acquired from the training is tailored to each target group and designed for safe, time-saving operation of your crane or else consolidates your specialist know-how of sales, marketing and service.

Our range of training programmes includes more than 20 different courses. Take advantage of our services:

- Training for prevention of accidents and crane operation.
- Crane technology training.
- Training tailored to your needs and level of experience, for different levels of difficulty from beginner to specialist.
- Theoretical and practical training, on simulators and on (your) crane.
- Training in the vicinity of GMK and GTK production.
- Training courses with the duration required by the individual; from two days to several weeks.
- Our coaches can also visit you to provide you with training on your own crane.

Have us design a suitable training programme for you today. We would be pleased to advise you! Your **Training Centre Wilhelmshaven**.

Our contact information and an overview of our current training courses can be found online at:

*[http://training.manitowoccranes.com/MCG\\_CARE/Services/EN/Training.asp](http://training.manitowoccranes.com/MCG_CARE/Services/EN/Training.asp)*

Make sure that the prescribed intervals and the intervals specified in the operation and maintenance manual for periodic inspections, tests and maintenance work are adhered to.

Replace the hydraulic hose lines, or have them replaced, at the prescribed intervals, even if no safety defects are noticeable.

Spare parts must fulfil the technical requirements defined by the manufacturer. Genuine spare parts always meet these requirements.

Appropriate servicing equipment is absolutely necessary in order to carry out maintenance work.

Observe national regulations that apply to transport when loading the truck crane. Also observe the prescribed safety measures of the carrying agent or railway company

Monitor the work of personnel, at least occasionally, and make sure they work in accordance with the operating instructions in a safe and conscientious manner.

## 2.3

### Personnel qualifications

This operating manual is not a training manual for prospective crane operators!

All descriptions are written explicitly for crane operators who have been trained to operate truck cranes.

Personnel in training may only operate the truck crane under supervision.

Only reliable personnel may operate or carry out work on the truck crane.



The number of reeved rope lines must be selected such that the load on the hoist rope does not exceed 50% of the rope pull. At the same time, the total weight of the lifted load must be considered, consisting of the weights of the hook block, the lifting gear and the equipment for lifting persons including the maximum payload.

When transporting persons, the crane operator must maintain the safe distances from overhead power lines applicable in the country in which he is working. The distances are normally greater than the distances for lifting loads specified in the *Safe distance from overhead power lines* section.

The person being transported must be in radio contact with the crane operator.

When used for transporting persons, the truck crane must not be used for other tasks.

The crane operator is not permitted to exceed the maximum permissible wind speeds and wind loads for transporting persons applicable in the country in which he is working. These values are normally lower than those for lifting loads specified in the *lifting capacity table*.

When the equipment for lifting persons is being used and is in a stationary position, then the slewing gear, hoist, derricking gear and telescoping mechanism must be secured against accidental use by being switched off.

### **Truck crane**

The truck crane must be equipped (e.g. with hydraulic emergency operation) so that the equipment for lifting persons can be set down and the persons being transported can safely leave it even if there is a failure of the drive or crane controls.

The hook that holds the lifting gear for the equipment for lifting persons must be fitted with a lockable latch that completely seals the hook opening.

The truck crane must be serviced as prescribed, regularly inspected and repaired, if required. All safety stickers must be affixed in their appropriate places and be legible.

<b>1</b>	Passenger's seat	➡ p. 5 - 14
<b>2</b>	Storage space or 2nd passenger seat <sup>1)</sup>	
<b>3</b>	Fire extinguisher <sup>1), 3)</sup>	
<b>4</b>	Instrument panel, left/right	➡ p. 3 - 12
<b>5</b>	Parking brake	➡ p. 3 - 55
<b>6</b>	Diagnostics	➡ p. 3 - 69
	Hydraulic emergency operation on/off <sup>1)</sup>	➡ p. 14 - 65
<b>7</b>	Auxiliary water heater <sup>1)</sup>	➡ p. 5 - 80
<b>8</b>	Accelerator	➡ p. 5 - 47
<b>9</b>	Service brake	➡ p. 5 - 35
<b>10</b>	Transmission operating elements	➡ p. 3 - 18
<b>11</b>	Steering column/steering wheel	➡ p. 3 - 17
<b>12</b>	Driver's seat	➡ p. 5 - 13
<b>13</b>	Behind driver's seat	
	– Warning triangle <sup>1)</sup>	
	– First-aid kit <sup>1)</sup>	
	– Warning lamp <sup>1)</sup>	
<b>14</b>	To open/lock door	➡ p. 3 - 71
<b>15</b>	Separate steering	➡ p. 3 - 58
<b>16</b>	Window winder	➡ p. 3 - 70

- <sup>1)</sup> Additional equipment  
<sup>2)</sup> ➡ *Separate operating instructions*  
<sup>3)</sup> ➡ *Maintenance Manual*



### 3.1.5

## Steering column/steering wheel

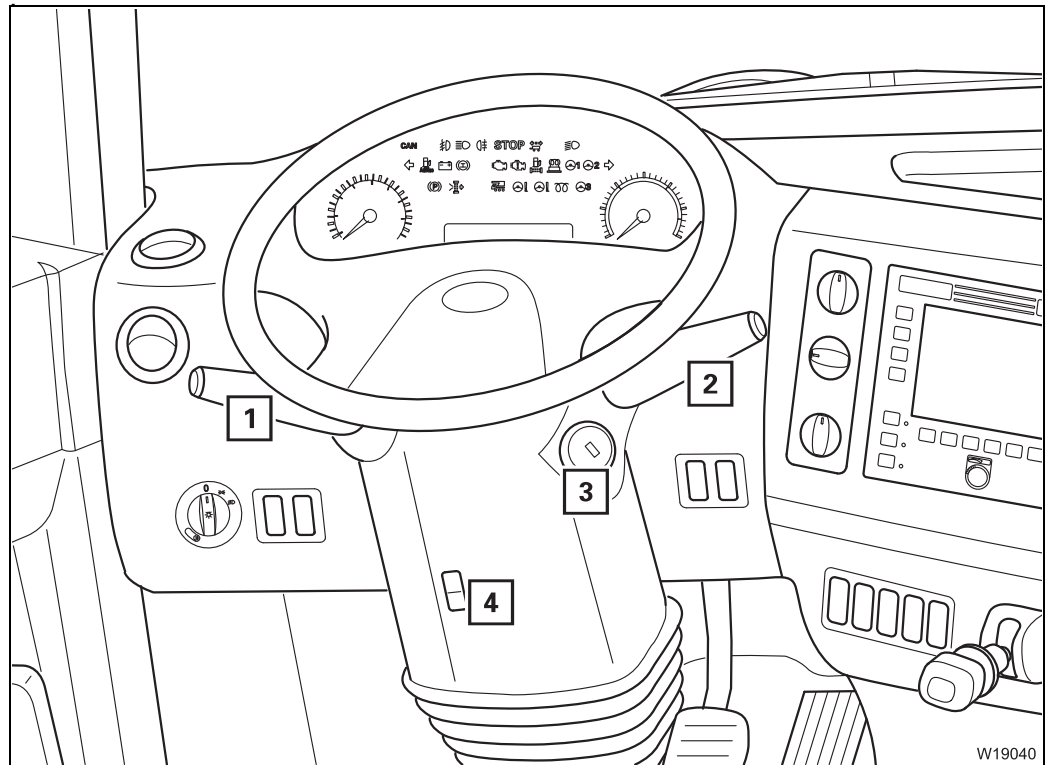

- |   |             |
|---|-------------|
| <b>1</b> Horn/headlight flasher/headlight – full beam | ➡ p. 3 - 60 |
| Turn signal indicator/wiper-washing system            | ➡ p. 3 - 60 |
| <b>2</b> – Set idling speed                           | ➡ p. 3 - 38 |
| – Setting the Tempomat                                | ➡ p. 3 - 38 |
| – Setting the Temposet                                | ➡ p. 3 - 38 |
| – Engine retarder/transmission retarder <sup>1)</sup> | ➡ p. 3 - 54 |
| <b>3</b> Ignition lock                                | ➡ p. 3 - 38 |
| <b>4</b> Adjusting the steering column                | ➡ p. 5 - 16 |

<sup>1)</sup> Additional equipment

## Monitoring submenu

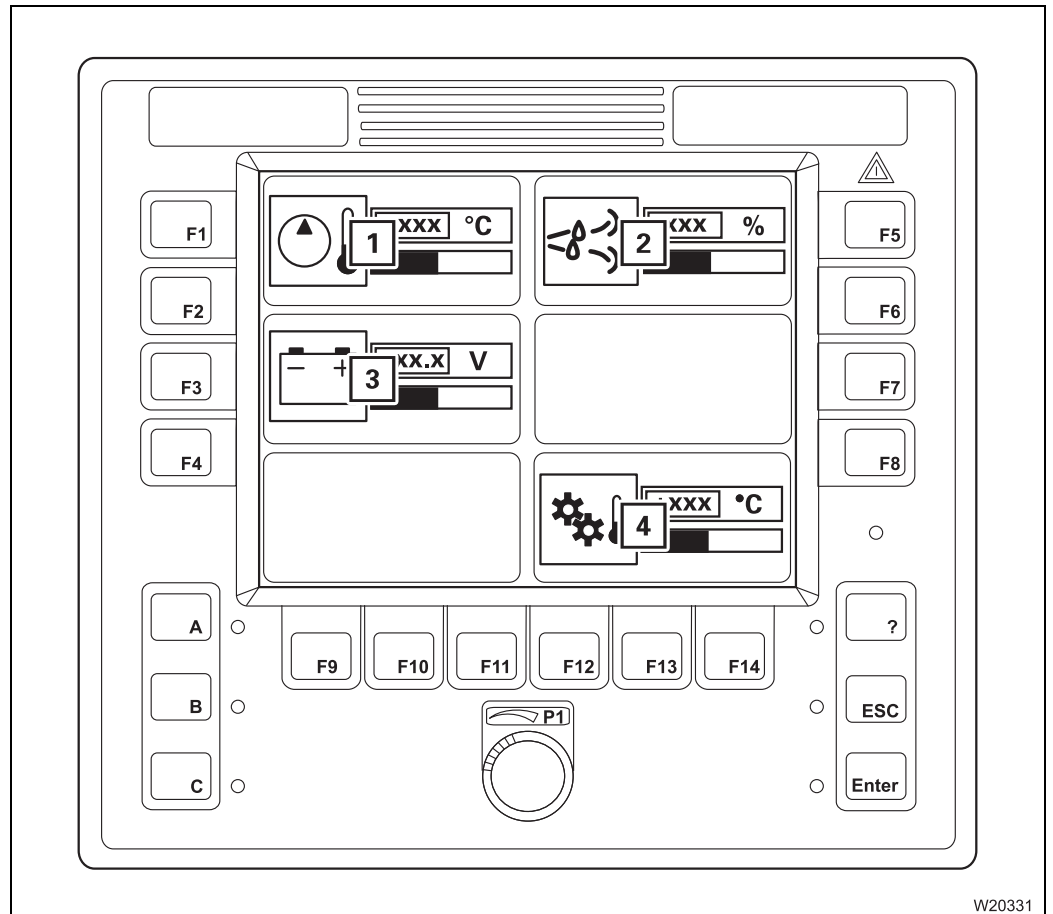

- |   |  |                |
|---|--|----------------|
| 1 | Hydraulic oil temperature display          | ▣▣▣▣ p. 4 - 21 |
| 2 | Carbamide supply display <sup>1), 2)</sup> | ▣▣▣▣ p. 4 - 21 |
| 3 | Voltage monitoring display                 | ▣▣▣▣ p. 4 - 21 |
| 4 | Transmission oil temperature display       | ▣▣▣▣ p. 4 - 21 |

<sup>1)</sup> Additional equipment



### 3.2.3

## General rules for buttons and symbols on the display

The symbols shown as an example are not present on all crane types.  
The following rules apply in all menus:

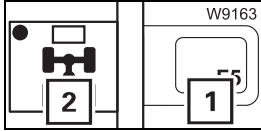

- A button (1) is only active when the corresponding symbol (2) is black. Buttons next to a grey symbol always have no function.

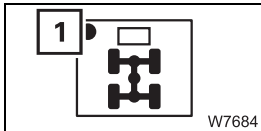

- Some symbols have a dot (1). The colour of the dot indicates the current switching state of the button.

- **Green:** button on – the corresponding gear change is being carried out
- **Black:** button off – the corresponding gear change is not being carried out

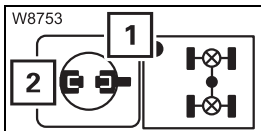

For some elements, the dot (1) only indicates that the gear change has been completed. Here, you will also receive a report on the current gear change on an extra display (2).

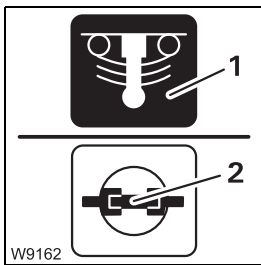

- In these operating instructions, we always refer to colours in terms of “The symbol is red”, for instance, regardless of whether the background (1) of a symbol is red or whether only parts (2) of a symbol are red. This applies to all symbols and all colours.

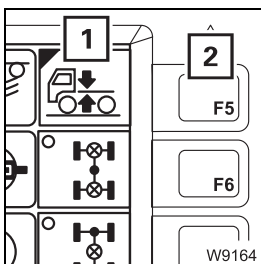

- If the instruction given in this section is to “Press the button once...”, for instance, this always refers to the button (2) next to or below the symbol shown (1). This applies even when the button itself is not visible in the illustration.

### 3.2.8

## Transmission

Operating the transmission, p. 5 - 27.

### Instrument panel, middle



#### Transmission malfunction

Switching on diagnostics/oil-level gauge; p. 3 - 50

### Display, driving mode

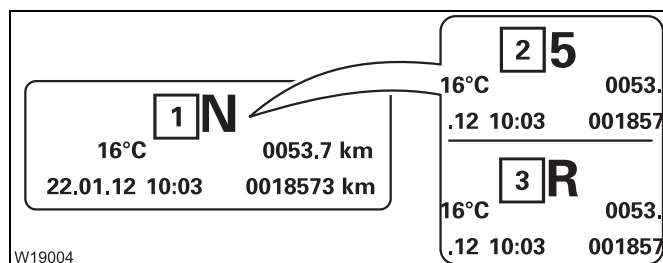

#### Transmission display

- 1 Neutral position switched on
- 2 Currently engaged gear – forwards (1 to 6), e.g. 5
- 3 Currently selected gear – reverse

### Transmission control unit



#### Transmission display

– Neutral position **N** switched on



– Gear position **R** switched on



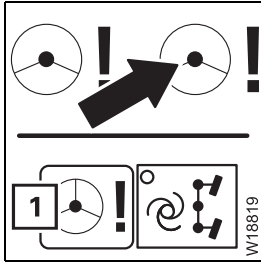

### Steering system warning

- **On:** Steering system defective – stop immediately, Display symbol (1) – 5th and 6th axle cannot be steered; if it is possible, it can only be steered in straight running position – max. 20 km/h
- **Off:** No error in the steering system

After engine start;  p. 4 - 18

While driving;  p. 5 - 28

### ECOS display

Main menu

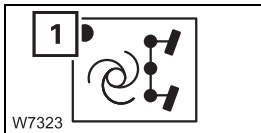

### Separate steering crab travel mode on/off

- **To switch on:** Press button once – dot (1) green, maximum 5 km/h
  - Steering wheel steers 1st and 2nd axle lines
  - 3rd to 6th axle line steer in the same direction
- **To switch off:** Press button once – dot (1) black

 p. 5 - 71

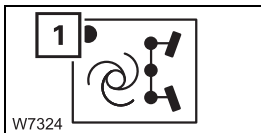

### Separate steering for driving around corners on/off

- **To switch on:** Press button once – dot (1) green, maximum 5 km/h
  - Steering wheel steers 1st and 2nd axle lines
  - 3rd to 6th axle lines steer for the smallest turning circle
- **To switch off:** Press button once – dot (1) black

 p. 5 - 71



### 3.2.17

## Tachograph/speedometer

▣▣▣▣▶ *Setting the tachograph*, p. 5 - 19.

### Tachograph

#### Correction of time

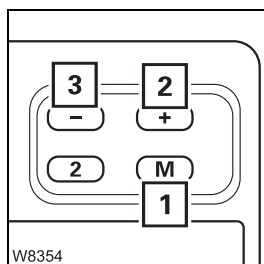

- 1 Open the time menu:** Press the button – the time correction menu opens
- 2 Time correction +:** Press the button – the time is increased
- 3 Time correction -:** Press the button – the time is decreased

### Speedometer

#### Display speed:

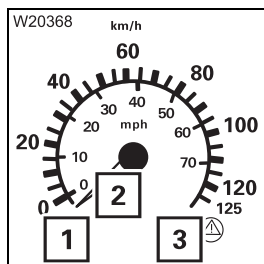

#### Speed indicator

- 1** Indicates the speed in km/h
- 2** Indicates the speed in mph
- 3** Tachograph malfunction warning

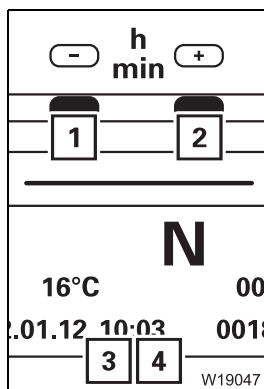

#### Setting the driving display time

- 1** Press the button – the time is increased
- 2** Press the button – the time is decreased

**Setting the hours (3):** Press buttons (1) + (2) once – press the button for setting within 10 seconds

**Setting the minutes (4):** Ignition on or do not press a button for approx. 10 seconds

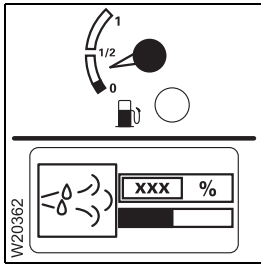

10. Check the fuel level and carbamide level if necessary; p. 4 - 7.

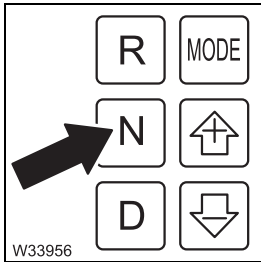

11. Shift the transmission to the neutral position; p. 5 - 28.

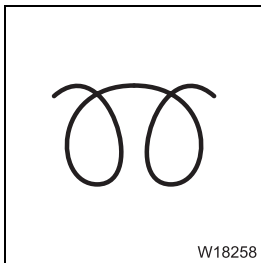

12. If the truck crane has a flame start system, wait until the lamp goes out; p. 4 - 16.

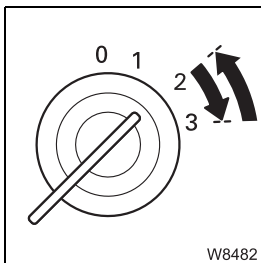

13. Start the engine; p. 4 - 15.

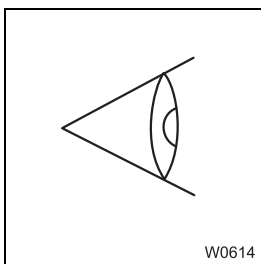

14. Conduct the necessary checks after starting the engine; p. 4 - 18.

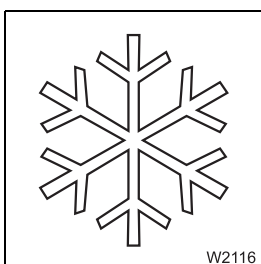

15. In the event of low outside temperatures; *CHECKLIST: At low temperatures, p. 4 - 4.*

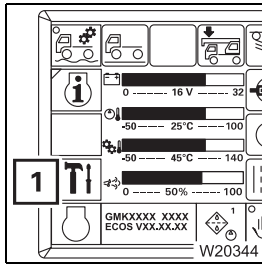

### Conducting the lamp test

- If necessary, open the main menu  and press the button (1) once. This opens the *Settings* submenu.

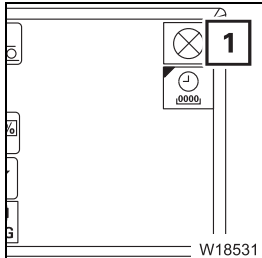

- Press the button (1). The lamps on the ECOS control unit remain lit until you let go of the button again.

You can adjust the minimum brightness of the display if necessary;  
 p. 4 - 14.

### Switching state alignment

When the ignition is switched on, the switching states of the differential locks and the separate steering are compared.

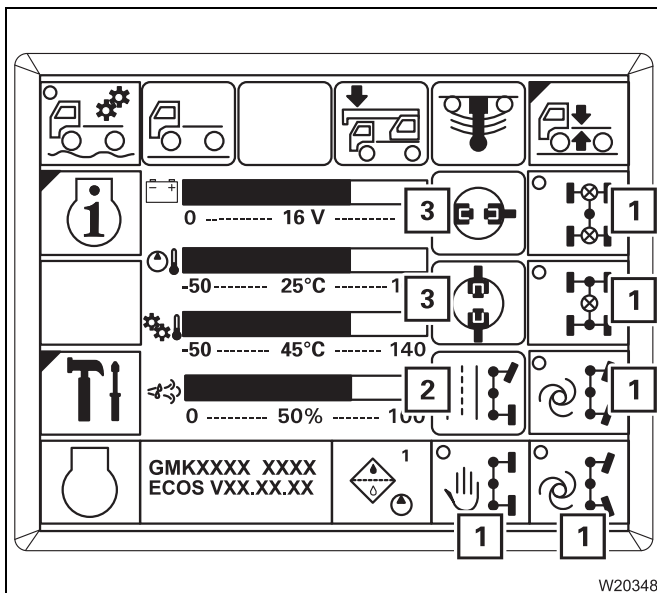

The state last saved is retrieved.

In the main menu, the corresponding symbols (1) are shown and the electronics system triggers the switching operations.

The displays (2) and (3) show the current switching states.

If the display (2) does not show the symbol that corresponds to the switching process, you must actuate the steering so that the locking processes are performed mechanically;  
 *switching to normal steering mode*, p. 5 - 74.

## 4.2

## Switch the engine off

### 4.2.1

### At the ignition lock and with the outrigger control units



#### **Risk of accidents because the truck crane cannot be steered!**

Switch the engine off only once the truck crane has come to a standstill. If you remove the ignition key, the steering will lock and you will lose control of the moving truck crane.

If the temperature of the coolant is very high, let the engine run on for another one or two minutes at increased idling speed.

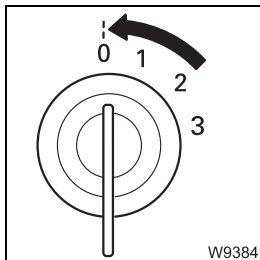

#### **Ignition lock**

- Turn the ignition key to position **0** – the engine will stop.

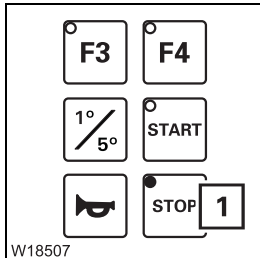

#### **Outrigger control units**

- Press the button **(1)** – the engine will switch off.

**After switching off** If you want to park the truck crane; p. 5 - 54.

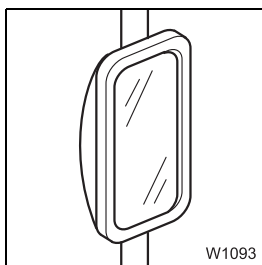

19. Adjust the mirrors; p. 5 - 8.

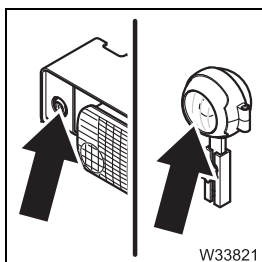

20. Adjust the reverse camera if necessary; p. 5 - 8.

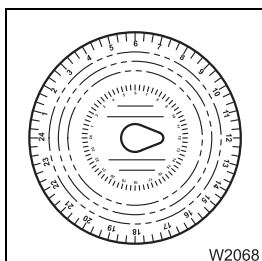

21. Set the tachograph, insert the diagram sheet; p. 5 - 19.

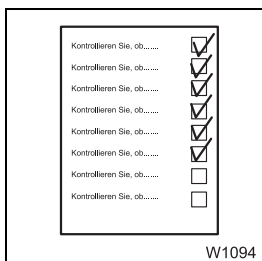

22. Start the engine and carry out all checks; *Checks after starting the engine*, p. 4 - 18.

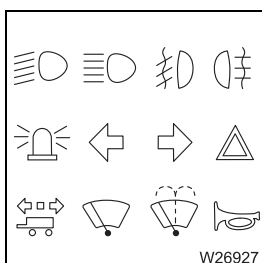

23. Check the electrical system; p. 5 - 7.



**Passenger's seat** The passenger's seat is adjusted mechanically.

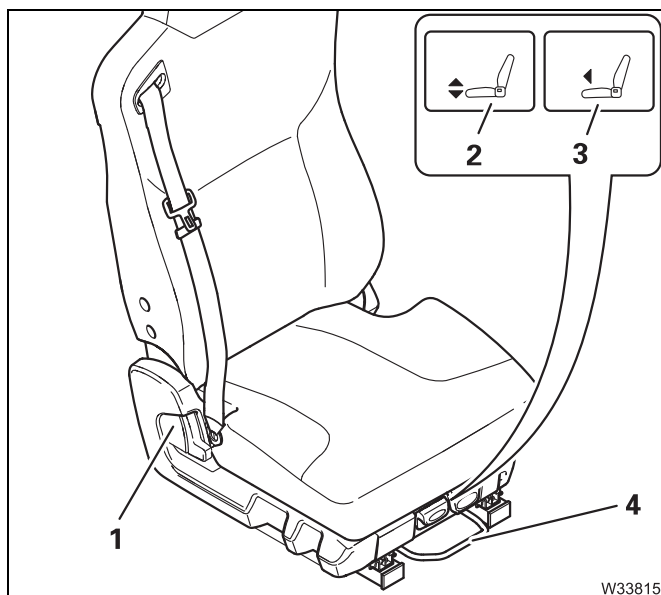

### Version 1

- 1 Back rest – angle
- 2 Seat cushion – angle
- 3 Seat cushion – longitudinal adjustment
- 4 Seat – longitudinal adjustment

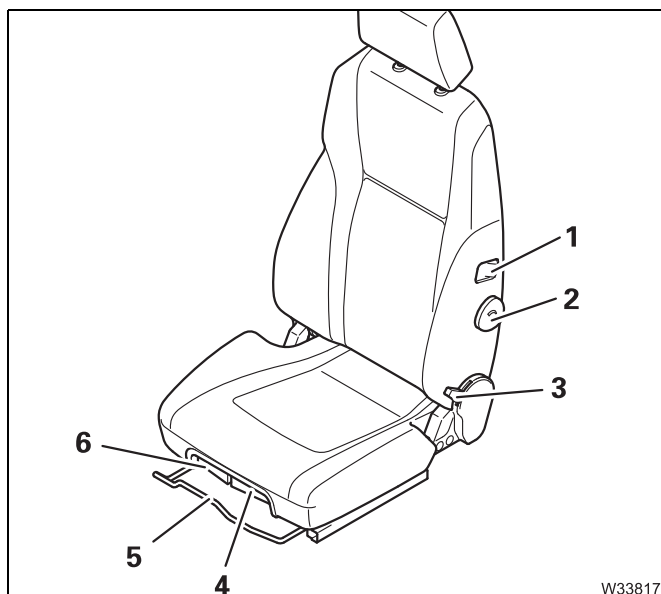

### Version 2

- 1 Seat heating on/off<sup>1)</sup>
- 2 Lumbar area support<sup>1)</sup>
- 3 Back rest – angle
- 4 Seat cushion – longitudinal adjustment
- 5 Seat – longitudinal adjustment
- 6 Seat cushion – angle

<sup>1)</sup> Additional equipment



## 5.1.6 Displaying the operating hours

You can view the operating hours for all power units in the *Operating hours* submenu.

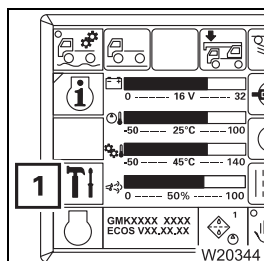

- If necessary, open the main menu and press the button **(1)** once.

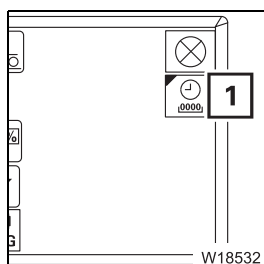

The *Settings* submenu opens.

- Press the button **(1)** once

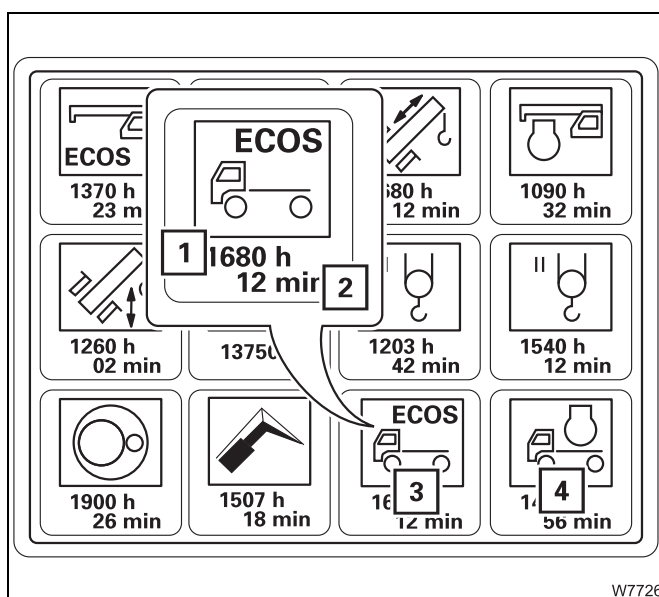

The *Operating hours* submenu opens.

When driving, the ECOS operating hours **(3)** for the carrier and the engine **(4)** for driving are recorded:

- The value **(1)** indicates the hours, e.g. 1,680 hours,
- The value **(2)** indicates the minutes, e.g. 12 minutes.

The other displays relate to crane operation;  
*Displaying the operating hours*, p. 11 - 109.

## 5.2.9

### Stopping

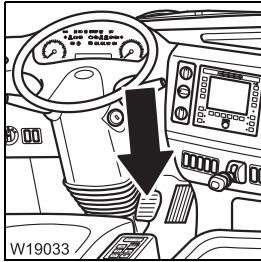

- In order to stop, take your foot off the accelerator and depress the brake pedal.

### Stopping for longer periods

- In order to stop for a longer time with the engine running, you must:
- Apply the parking brake and
  - Shift the transmission to the neutral position **N**.

## 5.2.10

### On the roller type dynamometer

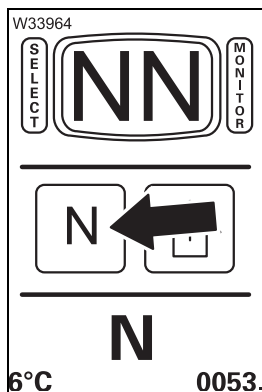

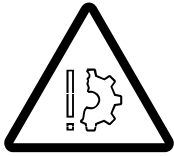

- Always switch to neutral position **N** after driving onto a roller type dynamometer.
- Allow the engine to keep running.



**Risk of damage from resonance vibrations!**

Always maintain a speed below 85 km/h. Stop the truck crane promptly.

When driving downhill, you can also slow down the truck crane as follows, in addition to using the service brake:

- By shifting down from the highest gear;  p. 5 - 45,
- with the additional brake;  p. 5 - 46,
- with the transmission retarder;  p. 5 - 47.

**Shifting down from the highest gear**

If you shift down from the highest gear, the braking force of the engine is increased.



- Shift down from the highest gear, e.g. to 4th gear.



- Brake the truck crane.  
When a permissible speed has been reached, the transmission will shift down.



You can also increase the braking force of the engine by switching to the **P (1)** driving mode.



If the maximum permissible speed is also reached in a lower gear, the transmission will automatically engage the highest gear and shift up.



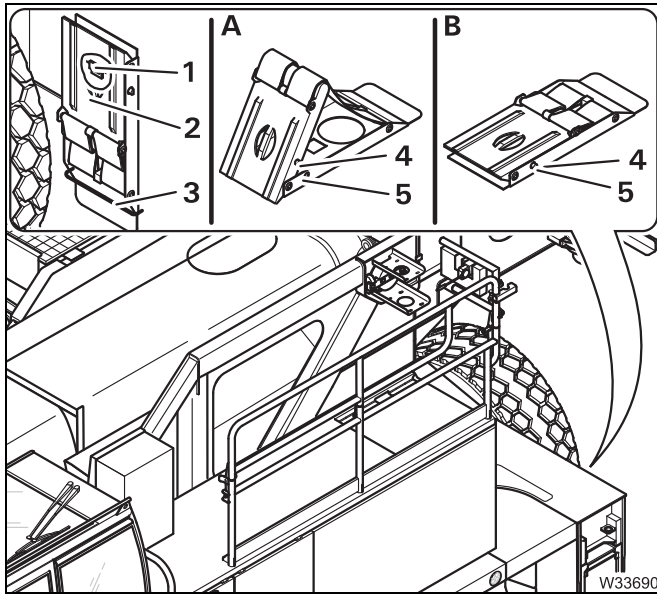

### Transport at the rear of the carrier

- Push the chock (2) behind the bracket (3) and hang it on the holder (1).

#### (A) – Folding out

- Push the latch (4) through the hole (5).  
The chock unfolds by spring force.

#### (B) – Folding up

- Push the chock together until the latch (4) engages in the hole (5).

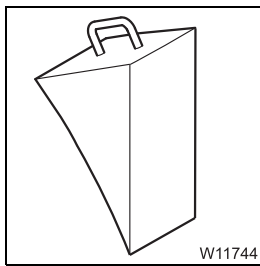

Additional chocks can be transported in the storage compartment on the turntable or at the rear of the truck crane.

### When stationary for more than 8 hours

- Switch off all current consumers, e.g. auxiliary heaters.
- Switch off the engine.



In order to prevent malfunctions, you should switch the battery master switch off only when the engine has been switched off.

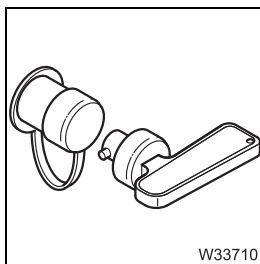

- Switch off the battery master switch.



### Setting the on-road level

For on-road driving, you must always set the on-road level in order to adhere to the specified overall height.

- Park the truck crane on a level surface.
- Straighten the steering.
- Press the button (1) until the symbol (2) turns **green**.

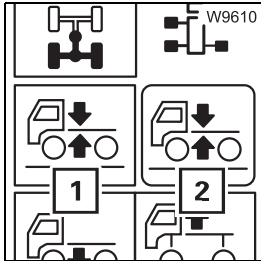

The display first shows the  symbol in **yellow** and when the on-road level has been reached, it shows the symbol (2) in **green**.

### Pre-selecting suspension struts

You can pre-select the suspension struts for five different level changes.

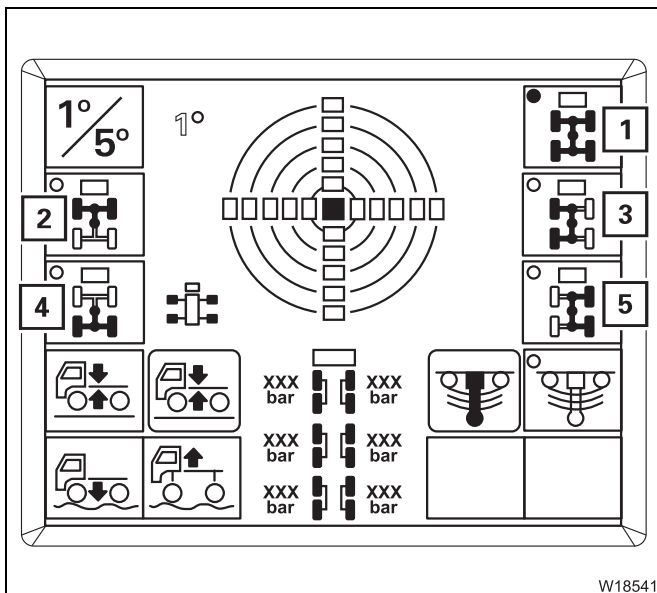

#### – For a uniform level change

- 1 Overall level – all suspension struts

#### – For inclination

- 2 Front level – suspension strut for the 1st to the 3rd axle line
- 3 Left level – all suspension struts on the left
- 4 Rear level – suspension struts for the 4th to 6th axle line
- 5 Right level – all suspension struts on the right

- Press the button next to the required symbol once – the dot turns **green**, e.g. for symbol (1).

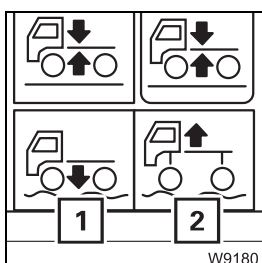

The corresponding suspension struts remain pre-selected for approx. 5 seconds.

During this time, the symbols (1) and (2) are **black** and the corresponding buttons are active.



## 5.6

## Heating and air-conditioning system

### 5.6.1

### Standard heating system

#### Switching on

- Start the engine. The heating output is only provided when the engine is running.

#### Heating

You must set the blower and the temperature.

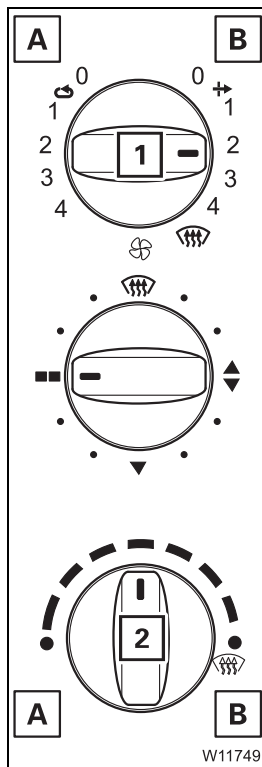

#### Setting the blower/fresh air/recirculated air

You can regulate the air volume with the switch (1) for:

- A** Recirculated air – air is sucked in from the driver's cab. Change to fresh air often to ensure that oxygen is supplied.
- B** Fresh air – outer air is sucked in.

- Turn the switch (1) to the desired level 1 to 4, Recommended – level 2.

#### Setting the temperature

- Turn the switch (2) to the desired position
  - A** Colder
  - B** Warmer
- Press the switch (2) several times in succession at least once a month in order to prevent malfunctions.



### Switching the automatic heating start on and off

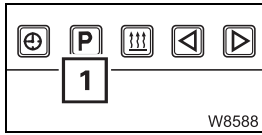

To switch on an automatic heating start, you must retrieve the corresponding storage location.

- To retrieve a storage location, press the button (1) once.



The display field flashes for 5 seconds and a storage location is shown (e.g. 2). The heating start at this storage location is now switched on.

To switch on a different heating start, press the **P** button repeatedly until the desired storage location is displayed. This heating start is switched on as soon as the display stops flashing.

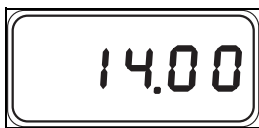

To switch off the automatic heating start, press the **P** button repeatedly until no storage location is displayed any longer.

### Setting the remaining run time

If the ignition is turned off while the auxiliary heater is running, the auxiliary heater continues to run for the remaining time.

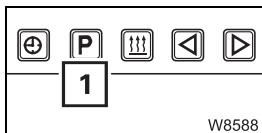

- Switch on the auxiliary heater using the button (1).

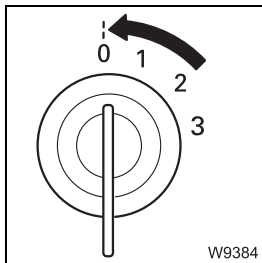

- Switch off the ignition.



The auxiliary heater continues to run and the residual run time set last flashes, e.g. 48 minutes.

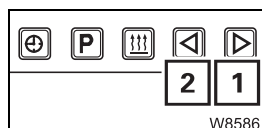

- Set the desired remaining time on the flashing display – button (1) or (2). You can set a remaining time of 1 to 120 minutes.

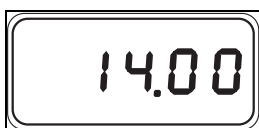

- Wait for 5 seconds until the current time is displayed. The remaining time is now set.

# 6

## Driving modes

This chapter contains:

- Tables with driving modes of the GMK6300L-1, in which the maximum axle load is 12 t .
- Rigging work required in order to set down the main boom on a trailer.
- Installation/removal of the main boom.

### 6.1

## Driving modes

### Information about the axle loads

The GMK6300L-1 truck crane is designed for driving with maximum axle loads of 12 t . **Manitowoc Crane Group Germany GmbH** points out that if the truck crane is driven with axle loads greater than 12 t , the brake system may overheat and the braking deceleration required by the EU partial type-approval cannot be met.

If country-specific regulations allow the truck crane to be driven with axle loads greater than 12 t , the crane driver/crane operator bears the sole responsibility for driving in this condition and for any subsequent damage. This also applies to damage due to premature wear.



#### **Risk of accidents from increased braking distance!**

When driving with axle loads in excess of 12 t , the braking deceleration required by the EU partial type-approval cannot be met. Please bear in mind that the braking distance of the truck crane will be increased.



#### **Risk of damage from premature wear!**

Premature wear of parts under particular strain (brake system, steering, tyres, wheels, suspension, drive shafts) cannot be ruled out even if the axle loads only briefly exceed 12 t .





## 6.3

### Rigging work for driving with a trailer

To reduce the axle loads to the specifications applicable in the country in which you are working, you can set the main boom on to a trailer (dolly) when driving.

For this purpose, the truck crane must be fitted with a slewing gear freewheel, boom floating position and if necessary, with a boom pre-tensioning device.

Before driving with the trailer, you must:

- Switch on the slewing gear freewheel;  p. 6 - 12,
- Switch on the boom floating position;  p. 6 - 13,
- Switch on boom pre-tensioning, if necessary;  p. 6 - 14,
- If necessary, mechanically unlock the turntable;  p. 11 - 14.

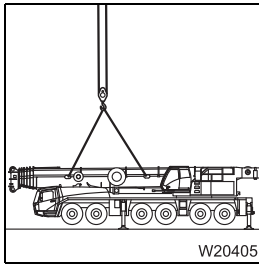

4. Sling the main boom to an auxiliary crane; ■■■▶ p. 6 - 26.

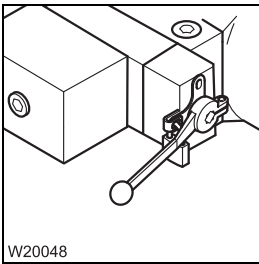

5. Switch on the derricking cylinder pressure relief; ■■■▶ p. 6 - 29.

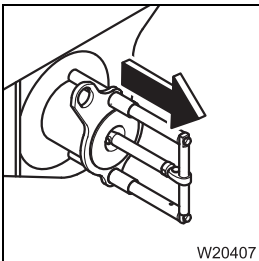

6. On the derricking cylinder head:

- Take the load off of the head pin,
- Release the head pin,
- Pull the head pins out;

■■■▶ p. 6 - 30.

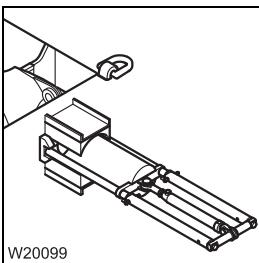

7. On the boom pivot pin:

- Switch the hydraulic circuit over,
- prepare the pulling device,
- Pull out the pivot pin;

■■■▶ p. 6 - 33.

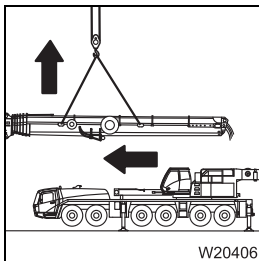

8. Raise the main boom from the turntable; ■■■▶ p. 6 - 38.



### Retracting the derricking cylinder head axle

After you have pulled the head pin, you can no longer derrick the main boom.

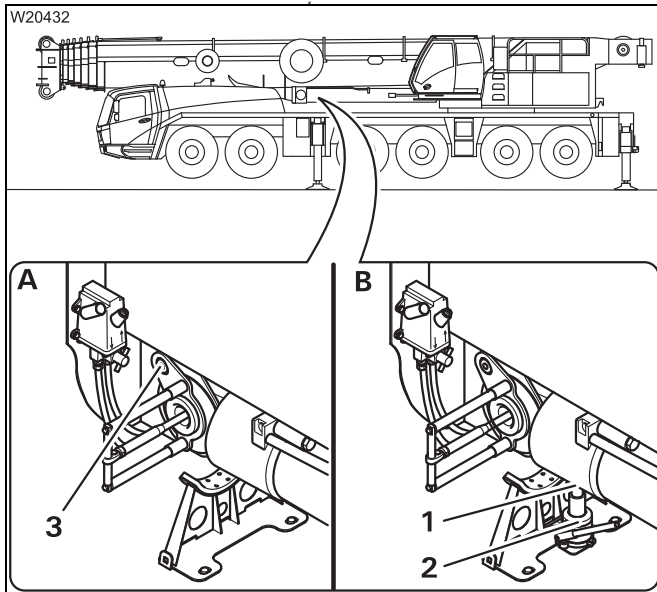

#### (A) – Releasing the head pin

- Loosen the bolt (3) and remove the disc.

#### (B) – Taking the load off of the head pin

- Place the lifting device (2) underneath the middle of the derricking cylinder.
- Carry out the movement *Raise* until the bracket (1) is resting firmly on the derricking cylinder.



#### Risk of accident from falling derricking cylinder!

Always take the load off of the derricking cylinder using the lifting device before retracting the head pin. This prevents the derricking cylinder from falling down, injuring people or being damaged when the bolts are undone.

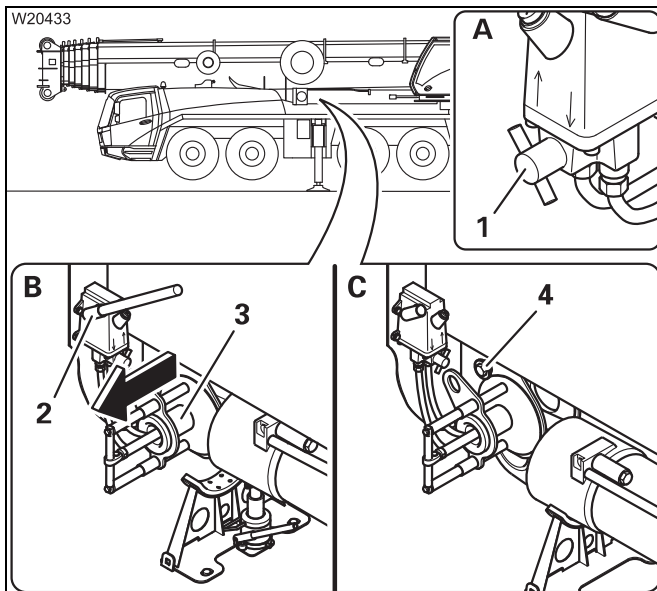

#### Pulling out the head pin

- (A) – Turn the switch (1) to the *pull* position .
- (B) – Insert the lever into the clamp (2).
- Pump until the head pin (3) is completely drawn out.
- Carry out the movement *Lower* until the derricking cylinder is in the derricking cylinder support.
- (C) – Fasten the disc with the bolt (4).
- Stow away the lever and the lifting device.



## 6.4.12

### Transporting the main boom

Transport the main boom only on a separate vehicle which is of sufficient size and has sufficient lifting capacity.

Transport dimensions and weight;  *Operating Manual*.

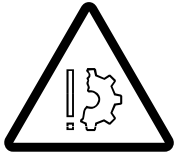

#### **Risk of damage to the main boom!**

Always place the main boom onto a suitable packing. If you lay the main boom on its side, add-on parts will be damaged.

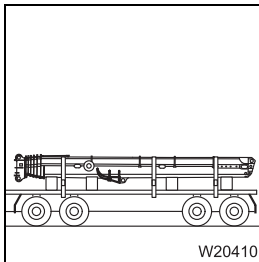

- Always place the main boom onto a suitable packing!
- Secure the main boom against slipping using the holding ropes.
- Load the main boom in such a way that other road users are not put at risk.
- Load the transport vehicle in such a way that the weight is evenly distributed.
- Secure the connection lines so that they will not slip and be damaged during transport.
- Keep the connecting points free of contamination.

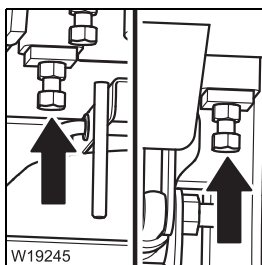

6. Screw in the spacers; p. 6 - 57.

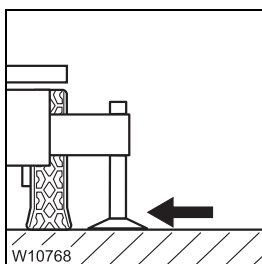

7. If necessary put outrigger pads into position; p. 6 - 53.

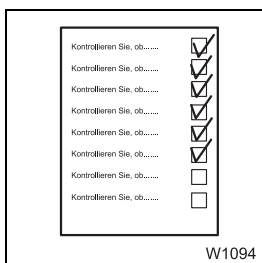

8. Mount all necessary outrigger beams in the same way in accordance with this checklist.

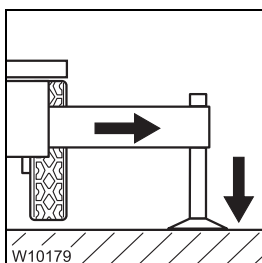

9. If the truck crane is at the site:

Extend the outrigger beams to the necessary outrigger span, secure them and stabilize the truck crane.

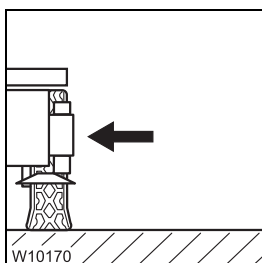

10. If the truck crane still has to be driven to the site:

Fully retract and secure the outrigger beams.

*Extending/retracting outrigger beams*, p. 12 - 35.

### Inserting the outrigger beam

- Only insert the outrigger beam at the correct installation point. Note the information on the label.



#### **Risk of being crushed by the swinging outrigger beam!**

Do not guide the outrigger beam with your hands when inserting it. Always use guide ropes and keep a suitable distance. This will prevent limbs from being crushed between the supporting box and the outrigger beam.



#### **Risk of damage to hydraulic lines!**

Ensure that the hydraulic lines on the outrigger beam do not remain hanging on the supporting box and become damaged.



#### **Risk of damage to the spacers!**

Check that all spacers have been screwed in completely. This prevents the spacers from remaining hanging in the supporting box and becoming damaged.

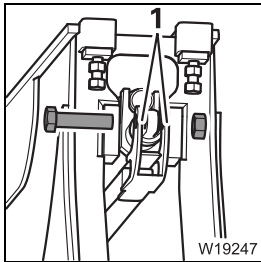

- Remove the connecting elements from the connecting points (1) of the supports.

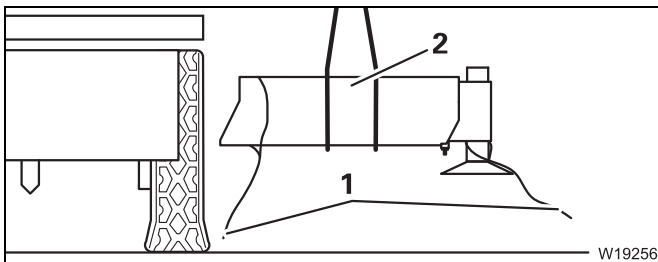

- Sling the outrigger beam at the centre of gravity (2).
- Fasten two guide ropes (1).

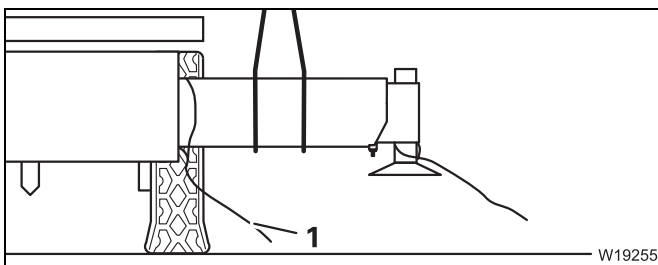

- Set the outrigger beam in the supporting box.
- Remove the guide rope (1).



### 6.6.3

### Rig the outrigger span 7.98 x 8.50/1.00 m

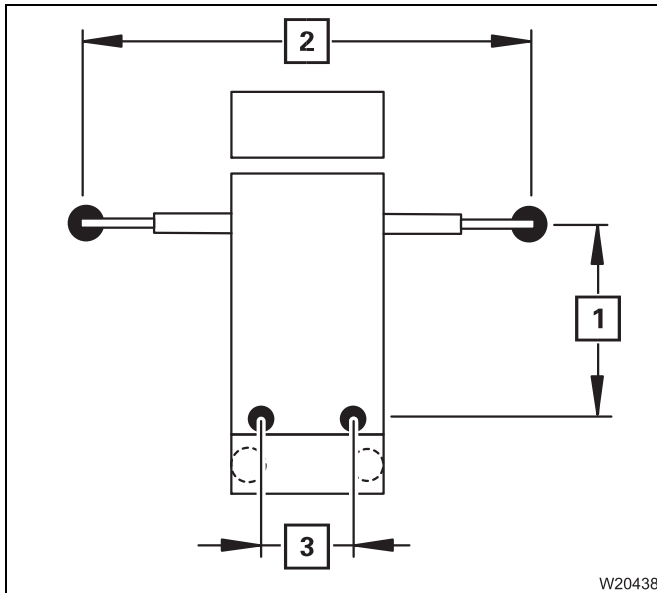

With this outrigger span, the truck crane is stabilised at the front to an outrigger width (2) 8.50 m. The auxiliary supports must be extended at the rear. This produces the outrigger span (3) of 1.00 m and the outrigger length (1) of 7.98 m.

You must rig this outrigger span before:

- Slewing the superstructure with the rear supporting box removed,
- Removing/installing the supporting box,
- Installing / removing the rear bumper,
- Setting down the main boom on a separate trailer, or raising the main boom from a trailer.



#### **Risk of damage to the suspension struts and tyres!**

Always extend the auxiliary supports before you perform one of the list processes.

This prevents the suspension struts and tyres from becoming overloaded and damaged.



Loads of up to 55.7 t can arise on the outrigger pads of the auxiliary supports when the truck crane only stands on the supports. If the ground cannot support these loads, you must determine the required support area and install the supports.

- ▮▮▮▮ *Determining the required load-bearing area, p. 12 - 9*
- ▮▮▮▮ *Enlarging the load-bearing area, p. 12 - 40*



## 6.6.9

### Crane movements during installation and removal

When the rear supporting box is removed, the setting down and raising of the main boom and the slewing of the superstructure is monitored by RCL. There are RCL codes for different working positions for an outrigger span of 7.98 x 8.50/1.00 m.



#### **Risk of overturning when slewing the superstructure!**

Always support the truck crane with an span of 7.98 x 8.50/1,00 m (with auxiliary supports at the rear) and set the corresponding RCL code before slewing the superstructure.

Do not override the RCL if slewing is switched off.

#### **Prerequisites**

The following prerequisites must be met:

- The auxiliary hoist must be removed.
- The counterweight is completely unrigged.
- The truck crane is rigged with an outrigger span of 7.98 x 8.50/1.00 m;  p. 6 - 71.
- The truck crane must be level.
- All telescopic sections are retracted and locked.

#### **Before installation**

- Enter the RCL code for an outrigger span of 7.98 x 8.50/1.00 m for the current main boom position (code for 0° position to the rear or 180° position to the front).
- Raise the main boom.
- Enter the RCL code for the outrigger span of 7.98 x 8.50/1.00 m for the 360° slewing range.
- Rotate the superstructure into the position for mounting the rear support.
- Enter the RCL code for the outrigger span of 7.98 x 8.50/1.00 m for the limited slewing range of ±20° to the rear.

#### **After the removal**

- Enter the RCL code for the outrigger span of 7.98 x 8.50/1.00 m for the 360° slewing range.
- Slew the superstructure into the position for setting down the main boom (0° to the rear, 180° to the front or ±15° to the rear).
- Enter the RCL code for the outrigger span of 7.98 x 8.50/1.00 m for the current main boom position.
- Set down the main boom on the boom rest or on a trailer.

## 6.7.2

### CHECKLIST: Auxiliary hoist, removing

#### Prerequisites

- The truck crane is supported with the required outrigger span as specified in the *Lifting capacity table*; ■■■▶ p. 12 - 30.
- The hoist rope on the auxiliary hoist must be unreeved and wound up.
- The superstructure is slewed to the rear.
- The 54.5 t counterweight combination is resting on the counterweight platform; ■■■▶ p. 12 - 62,  
or
- Install the rigging frame for counterweight combinations of up to a maximum of 26 t .

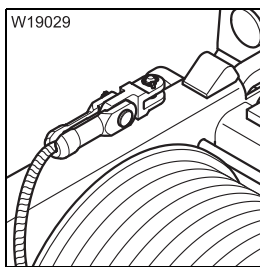

1. – Secure the hoist rope; ■■■▶ p. 6 - 101.

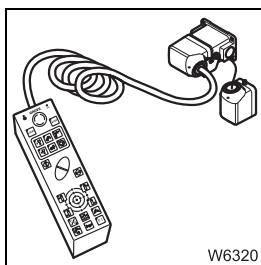

2. Connect the hand-held control at the right rear of the turntable; ■■■▶ *Connecting/disconnecting the hand-held control*, p. 12 - 21.

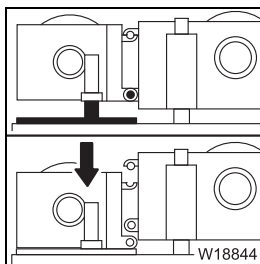

3. Removing the connection to the turntable:

- Lower the lifting frame; ■■■▶ p. 6 - 100.
- Remove the connection to the turntable; ■■■▶ p. 6 - 98.
- Lower the auxiliary hoist; ■■■▶ p. 6 - 100.

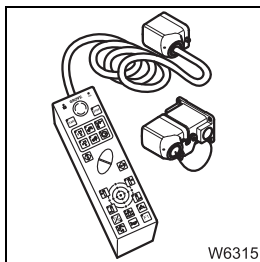

4. If necessary, disconnect and stow the hand-held control; ■■■▶ *Connecting/disconnecting the hand-held control*, p. 12 - 21.



## 6.7.9

### Securing the hoist rope

If you have wound up the hoist rope, you must secure it prior to removal.



#### **Risk of accident from damaged auxiliary hoist rope!**

Always secure the hoist rope prior to removal.

This prevents the hoist rope from being damaged and being overloaded during crane operation.

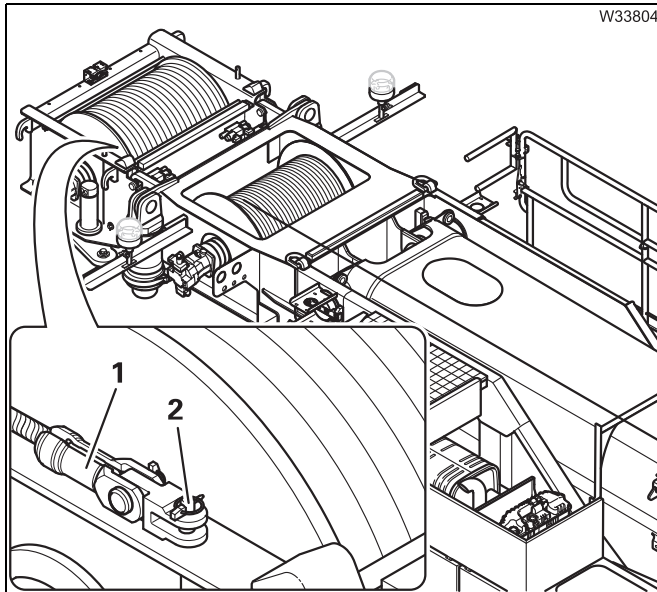

- Attach the rope end fitting (1) to the holder (2).
- Always secure the rope end fitting with a linchpin.

## 7.3

### Towing the truck crane

Observe the following when towing the truck crane:

- The truck crane may only be towed away with a tow-rod. Attach the tow-rod to the tow-rod coupling on the front bumper.
- Be sure to observe the statutory regulations of the country in which you are working concerning the overall length of the towing and towed vehicle, including tow-rod.
- If the engine, steering and service brake still work, you can tow the truck crane with a lorry.
- If the engine, steering or service brake no longer function properly, the truck crane must be towed with a special breakdown truck.

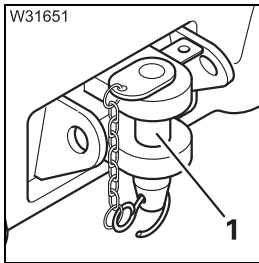

The front towing coupling is designed for a maximum tractive force of 10 t . Tensile force may be applied only forwards or at an angle of 45° to both sides of the longitudinal axis of the truck crane.

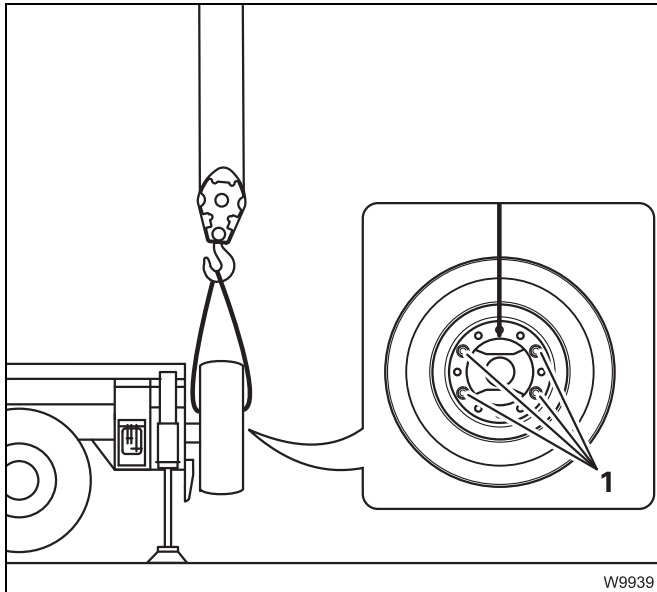

### Removing a wheel

- Undo the wheel nuts (1).
- Lift the spare wheel off the spare wheel holder.
- Secure the spare wheel against falling over if you put it down temporarily.

### Mounting a wheel

- Lift the wheel on to the spare wheel holder.
- Secure the wheel with the nuts (1) and tighten them to 500 Nm .

### Mounting a wheel

- Check that the bearing surfaces of the wheel rim and hub are clean (no paint, grease or oil).
- Lightly grease the wheel studs.



#### **Risk of accidents!**

Check the wheel rim, tyres, lug nuts and wheel studs for damage before mounting the spare wheel.

Damaged parts may not be mounted!

Mount only the original wheel as listed in the spare parts list or a permitted wheel of the same size and load bearing capacity!

- Place the wheel at the hub in an upright position.
- Extend or retract the outrigger cylinders until the holes in the wheel rims are in line with the wheel studs.
- Push the wheel on to the wheel studs. Make sure the threads of the wheel studs are not damaged.



## 7.5.2

### Fuses in the battery box

Fuses F7 to F10 are contained in the battery box.

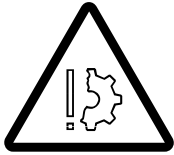

#### **Danger from lead and lead compounds on batteries!**

Battery poles, battery terminals and parts of the battery itself contain lead and lead compounds. Wash your hands after working on these parts or in these areas!

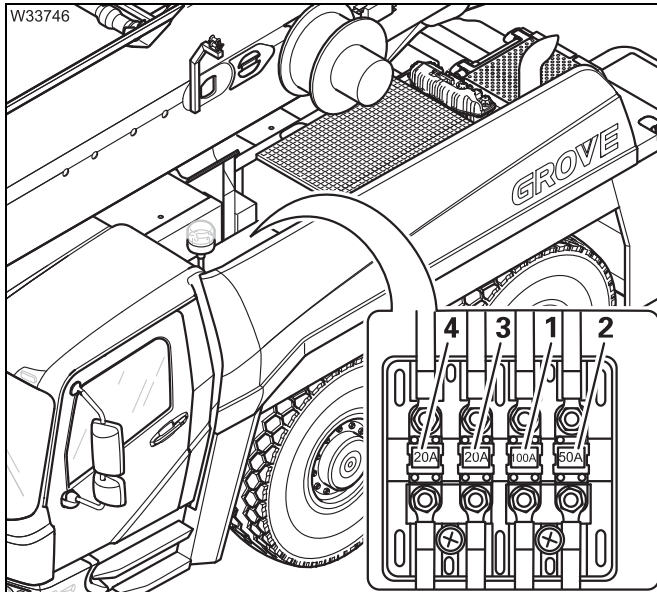

- Open the battery box.

The fuses are in a terminal box next to the batteries.

- Remove the lid from the terminal box:

- 1 Fuse F7
- 2 Fuse F8
- 3 Fuse F9
- 4 Fuse F10

Designation	Amperage (A)	Function
F7	100	Carrier central fuse
F8	50	Flame start system
F9	20	Preliminary fuse for auxiliary heater switch timer, tachograph and radio
F10	20	Unassigned

- Observe the instructions on changing fuses; p. 7 - 19.

## 7.6.11 Malfunctions on the ECOS carrier

This section contains general malfunctions and malfunctions that generate an "error" display.

### ECOS programme version

Always note down the number of the program version after a malfunction occurs before notifying **Manitowoc Crane Care**.

- If required, open the main menu .

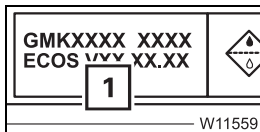

The display (1) shows the number of the current program version.

### General malfunctions

The following table contains information on troubleshooting and possible solutions.

Malfunction	Cause	Remedy
Ignition on – ECOS display does activate	Fuse F1/5, F4/6 blown.	Replace the blown fuse;  p. 7 - 20.



If further malfunctions occur, the appropriate error messages are shown in the ECOS display.



---

# 8

## Index



To avoid making the index unnecessarily long and unclear, we have not included every single element from the instrument panel. Those elements, such as switches and buttons, lamps and displays are described and named in detail in the overviews of Chapter 3 and Chapter 9 *Truck Crane Description*. From there you will as usual be referred to more detailed descriptions of these elements.

<b>L</b>	Ladders and access ladders .....	4 - 4
	Level adjustment system	
	Changing the vehicle level .....	5 - 66
	Exiting the submenu .....	5 - 67
	Opening the submenu .....	5 - 64
	Operating elements .....	3 - 64
	Pre-selecting suspension struts .....	5 - 65
	setting the on-road level .....	5 - 65
	Viewing the current inclination .....	5 - 66
	Lifting limit switch	
	Installing .....	12 - 106
	locking .....	12 - 110
	Releasing locking .....	12 - 111
	Removing .....	12 - 109
	Lighting .....	3 - 61
	driver's cab, inside .....	3 - 63
	Hazard warning system .....	3 - 61
	Instruments .....	5 - 26
	Operating elements in the crane cab .....	9 - 111
	Outriggers .....	3 - 62
	parking light/headlight - full beam .....	3 - 60
	Rotating beacon .....	3 - 62
	superstructure lighting .....	6 - 17
	Turn signal indicators .....	3 - 61
	Locks	
	on the carrier	
	in the battery box .....	7 - 25
	in the driver's cab .....	7 - 20
	on the superstructure	
	for the RCL .....	14 - 12
	In the crane cab .....	14 - 9
	On the turntable .....	14 - 6
	Longitudinal differential locks	
	operation from the driver's cab .....	5 - 62
	while towing .....	7 - 7
<b>M</b>	Main boom	
	Lowering to the horizontal .....	11 - 65
	Main boom, removing/installing	
	additional equipment required .....	6 - 19
	Aligning the connecting points .....	6 - 40
	CHECKLIST	
	installing the main boom .....	6 - 23
	removing the main boom .....	6 - 20
	Connecting/disconnecting the derricking cylinder from the boom .....	6 - 30
	disconnecting/connecting	
	hydraulics/electrical .....	6 - 36
	extending/retracting the boom pivot pin .....	6 - 33
	Inspections after main boom mounting .....	6 - 42

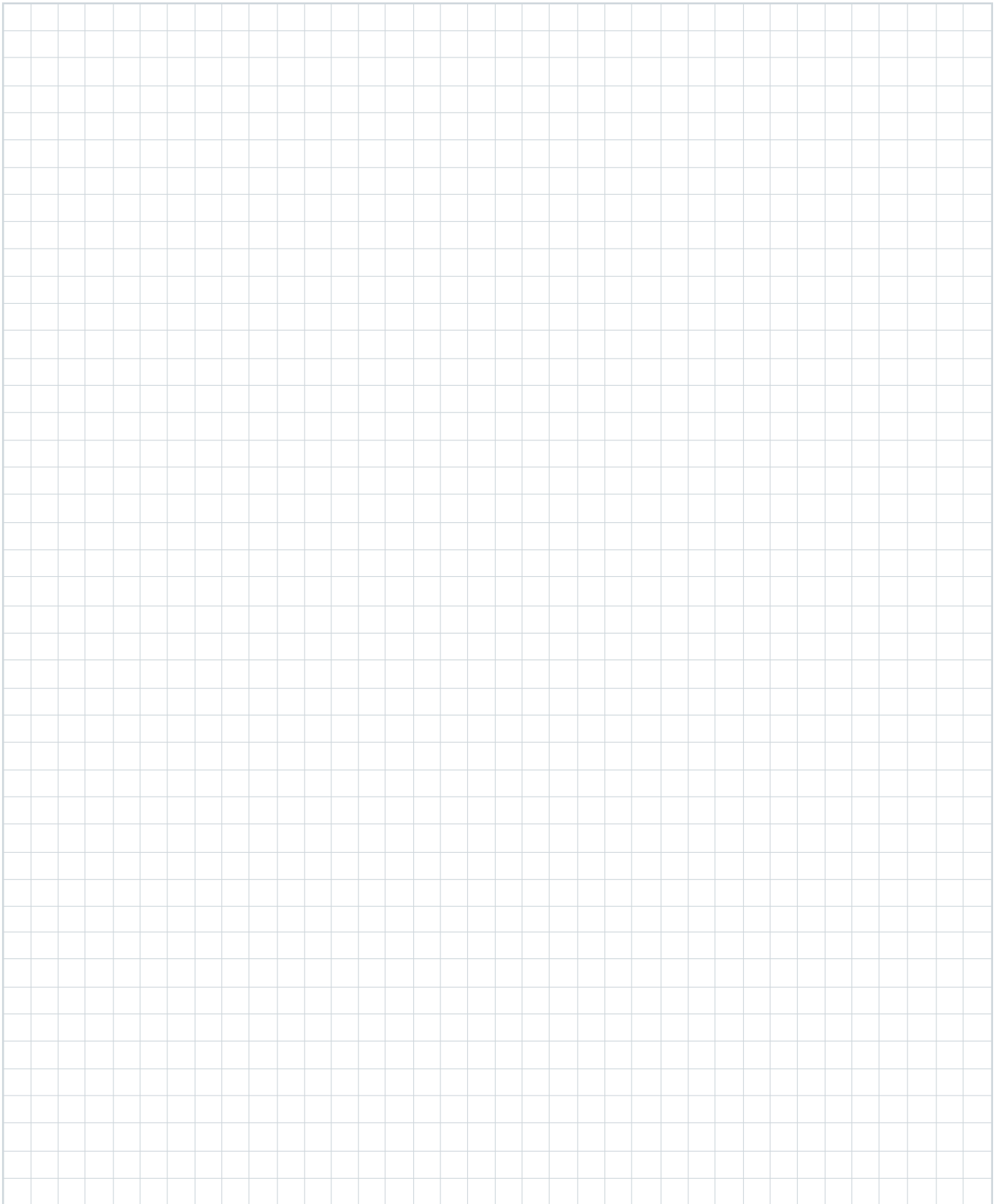

Grove

Manitowoc

National Crane

Potain



## 5 sheave hook block

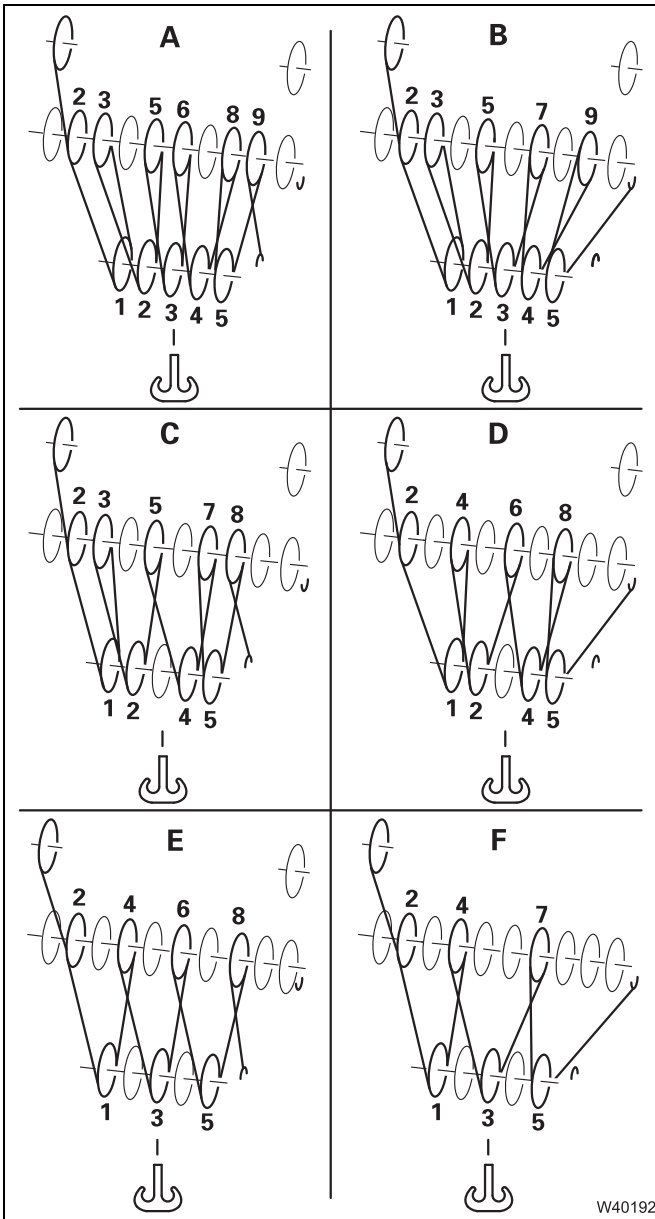

Reeving

- A** 11x
- B** 10x
- C** 9x
- D** 8x
- E** 7x
- F** 6x



W40192

# 9

## Operating elements for crane operation

All operating elements for driving are described in Chapter 3.

### 9.1

### Overview of the operating elements

This section shows the position and designations of the operating elements for crane operation. This also includes display elements such as lights or displays.



Operating elements available only with additional equipment are designated accordingly. These designations are made in this section only and are not repeated in the following sections.

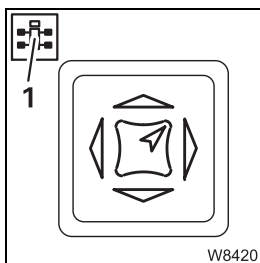

Some figures show details from a different perspective than the general overview. The perspective is indicated in these figures by the symbol (1).

<b>1</b>	<b>Air vents</b>	▣▣▣▣ p. 11 - 132
<b>2</b>	<b>High speed monitoring for the hoists</b>	▣▣▣▣ p. 9 - 79
<b>3</b>	<b>Windscreen wiper on/off</b>	▣▣▣▣ p. 9 - 113
<b>4</b>	<b>Roof window wiper on/off</b>	▣▣▣▣ p. 9 - 113
<b>5</b>	<b>Windscreen washing system</b>	▣▣▣▣ p. 9 - 113
<b>6</b>	<b>High-speed monitoring for derricking gear / telescoping mechanism</b>	▣▣▣▣ p. 9 - 85
<b>7</b>	<b>Spotlight sockets on/off</b>	▣▣▣▣ p. 9 - 111
<b>8</b>	<b>Sleuable spotlight on/off<sup>1)</sup></b>	▣▣▣▣ p. 9 - 112
<b>9</b>	<b>Air traffic control light/camera on/off/Camera<sup>1)</sup> 2)</b>	▣▣▣▣ p. 9 - 111
<b>10</b>	<b>Swing the spotlight<sup>1)</sup></b>	▣▣▣▣ p. 9 - 112
<b>11</b>	<b>Flame start system monitoring<sup>1)</sup></b>	▣▣▣▣ p. 9 - 59
<b>12</b>	<b>Voltage monitoring warning</b>	▣▣▣▣ p. 9 - 110
<b>13</b>	<b>Carrier ignition monitoring</b>	▣▣▣▣ p. 9 - 59
<b>14</b>	<b>Rotating beacons on/off<sup>1)</sup></b>	▣▣▣▣ p. 9 - 111
<b>15</b>	<b>Houselock on/off<sup>1)</sup></b>	▣▣▣▣ p. 9 - 94
<b>16</b>	<b>Set idling speed</b>	▣▣▣▣ p. 9 - 59
<b>17</b>	<b>Carrier ignition on/off</b>	▣▣▣▣ p. 9 - 60
<b>18</b>	<b>Air-conditioning system<sup>1)</sup></b>	▣▣▣▣ p. 11 - 133
<b>19</b>	<b>Ignition lock</b>	▣▣▣▣ p. 9 - 59
<b>20</b>	<b>Cigarette lighter (24 volts)</b>	

<sup>1)</sup> Additional equipment

<sup>2)</sup> Symbol according to execution



<b>1</b>	<b>ECOS display</b>	▣▣▣▣▶ p. 9 - 65
	Main menu overview	▣▣▣▣▶ p. 9 - 22
<b>2</b>	<b>Sensor for brightness<sup>1)</sup></b>	▣▣▣▣▶ p. 9 - 65
<b>3</b>	<b>Error/warning message</b>	▣▣▣▣▶ p. 9 - 63
<b>4</b>	<b>Buttons F1 to F14</b>	▣▣▣▣▶ p. 9 - 63
<b>5</b>	<b>Sensor for brightness<sup>1)</sup></b>	▣▣▣▣▶ p. 9 - 65
<b>6</b>	<b>Opening the Error submenu</b>	▣▣▣▣▶ p. 9 - 63
	Submenu overview	▣▣▣▣▶ p. 9 - 38
<b>7</b>	<b>Entering the keycode</b>	▣▣▣▣▶ p. 9 - 64
<b>7.1</b>	<b>Opening the Warning submenu</b>	▣▣▣▣▶ p. 9 - 63
	Submenu overview (superstructure)	▣▣▣▣▶ p. 9 - 24
<b>7.2</b>	<b>Open Warning submenu</b>	▣▣▣▣▶ p. 9 - 64
	Submenu overview (carrier)	▣▣▣▣▶ p. 9 - 36
<b>8</b>	<b>Exiting the submenu/input mode</b>	▣▣▣▣▶ p. 9 - 64
<b>9</b>	<b>Slewing gear brake applied/released</b>	▣▣▣▣▶ p. 9 - 81
<b>10</b>	<b>Entering values</b>	▣▣▣▣▶ p. 9 - 64
<b>11</b>	<b>Warning for lifting limit switch shutdown</b>	▣▣▣▣▶ p. 9 - 79
<b>12</b>	<b>Input confirmation</b>	▣▣▣▣▶ p. 9 - 64

<sup>1)</sup> Either **2** or **5**



Various menus are shown on the *ECOS* display. The menus are operated using buttons F1 to F14. The individual buttons have a different function in each menu. The functions of the buttons in the displayed menu correspond to the symbols next to or above the buttons; ▣▣▣▣▶ p. 9 - 63.

## Monitoring submenu

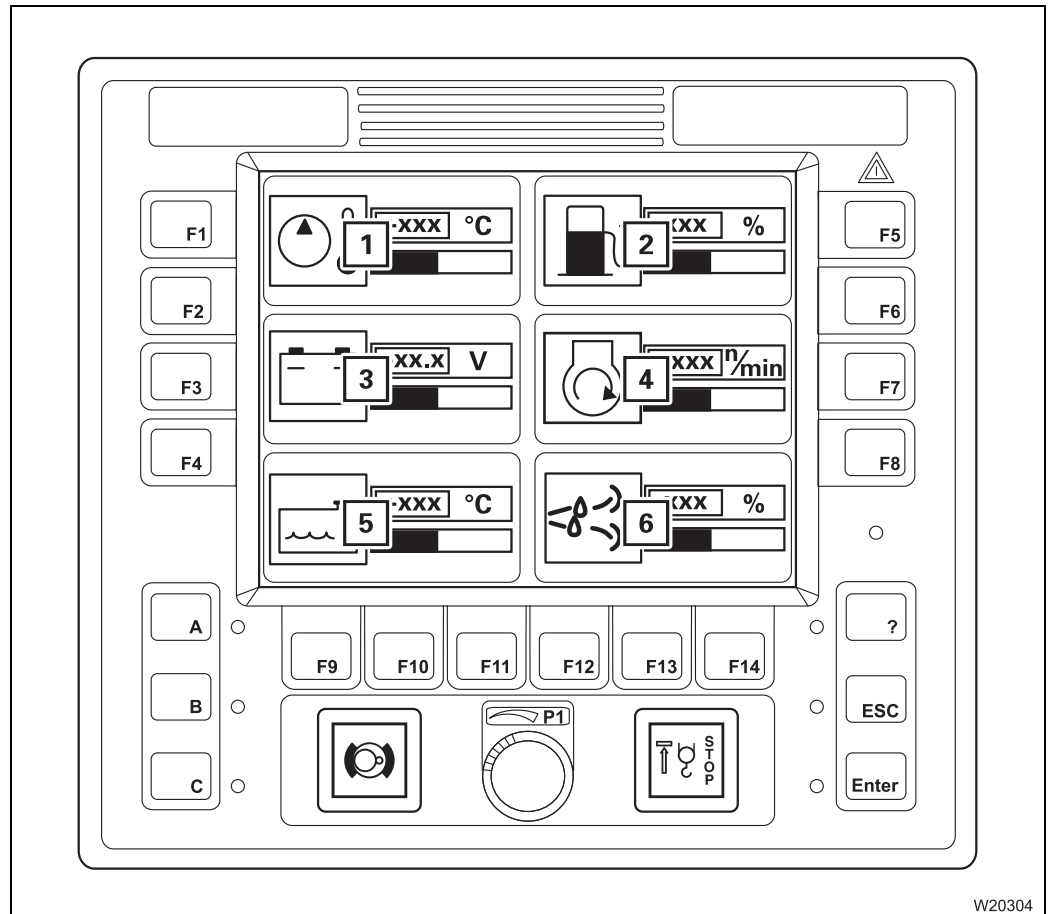

- |          |  |                 |
|----------|--|-----------------|
| <b>1</b> | Hydraulic oil temperature display          | ▣▣▣▣ p. 10 - 15 |
| <b>2</b> | Fuel level display                         | ▣▣▣▣ p. 10 - 15 |
| <b>3</b> | Voltage monitoring display                 | ▣▣▣▣ p. 10 - 15 |
| <b>4</b> | Engine speed display                       | ▣▣▣▣ p. 10 - 15 |
| <b>5</b> | Coolant temperature display                | ▣▣▣▣ p. 10 - 15 |
| <b>6</b> | Carbamide supply display <sup>1), 2)</sup> | ▣▣▣▣ p. 10 - 15 |

<sup>1)</sup> Additional equipment



CLICK HERE TO **DOWNLOAD** THE COMPLETE MANUAL

- Thank you very much for reading the preview of the manual.
- You can download the complete manual from: [www.heydownloads.com](http://www.heydownloads.com) by clicking the link below



- Please note: If there is no response to CLICKING the link, please download this PDF first and then click on it.

CLICK HERE TO **DOWNLOAD** THE COMPLETE MANUAL

## 9.1.11 RCL display – main menu

The main menu shows symbols for further submenus and symbols for current displays.

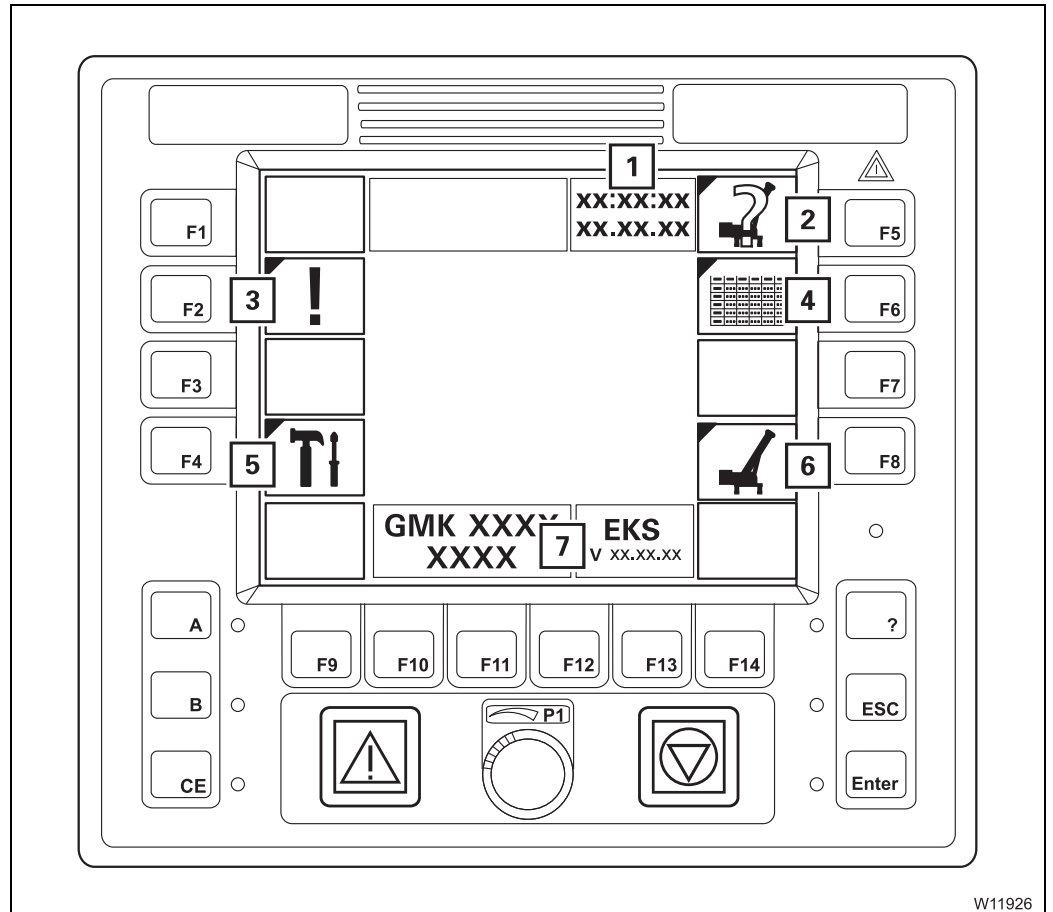

W11926

- |   |                |
|---|----------------|
| <b>1</b> Date/time display                          | ▣▣▣▣ p. 9 - 97 |
| <b>2</b> Enter rigging mode submenu                 | ▣▣▣▣ p. 9 - 43 |
| <b>3</b> Error submenu                              | ▣▣▣▣ p. 9 - 49 |
| <b>4</b> Lifting capacity table submenu             | ▣▣▣▣ p. 9 - 47 |
| <b>5</b> Settings submenu                           | ▣▣▣▣ p. 9 - 50 |
| <b>6</b> Monitoring submenu                         | ▣▣▣▣ p. 9 - 44 |
| <b>7</b> Serial number and program version displays | ▣▣▣▣ p. 9 - 65 |

### 9.1.13 Hand-held control

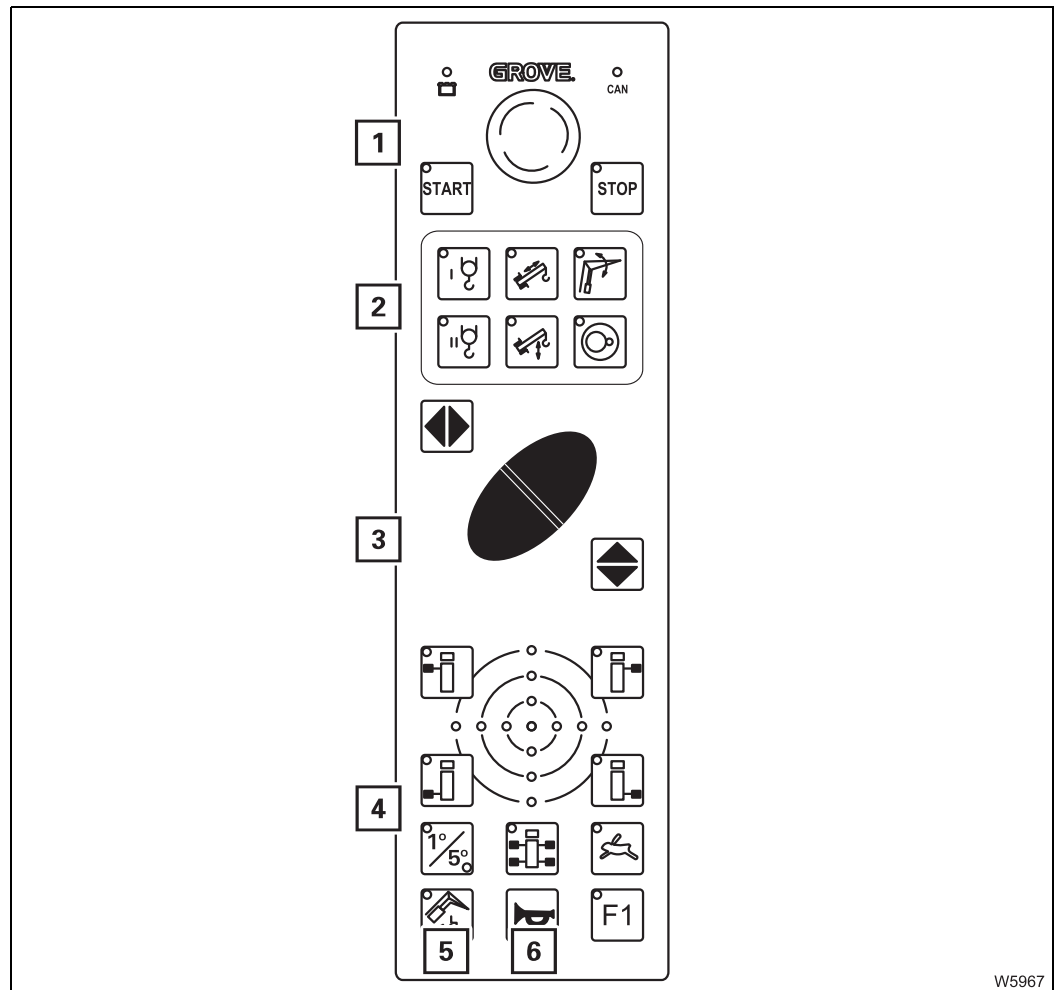

W5967

- 1 Engine control panel ➡ p. 9 - 115
- 2 Pre-select emergency operation ➡ p. 9 - 116
- 3 Function buttons ➡ p. 9 - 116
- 4 No function
- 5 No function
- 6 Horn ➡ p. 9 - 115



Required connections for the various movements; ➡ p. 9 - 114.

## Outriggers submenu

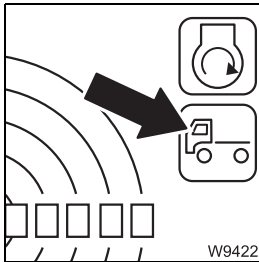

### Carrier ignition display

- **Red:** Ignition off – engine start not possible
- **Green:** Ignition on – engine start possible

▣▣▣▣ p. 12 - 23

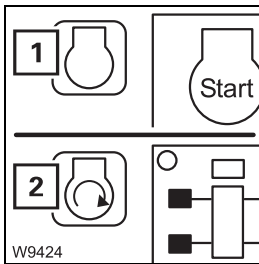

### Display for engine for driving on/off

- 1 Red:** Engine off
- 2 Green:** Engine on

▣▣▣▣ p. 12 - 23

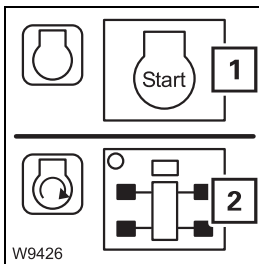

### Start engine for driving

- 1 Starting the engine:** Press button once
- 2 Engine running:** Button has function *Pre-select all supporting cylinders*
- Switch off the engine:** Switch off the carrier ignition

▣▣▣▣ p. 12 - 23

## 9.2.9

### Raise axle

When the suspension is switched off (blocked), the *Raise axle* function can be used to raise or lower axle lines or axle pairs, depending on the selection made.

#### Outrigger control units

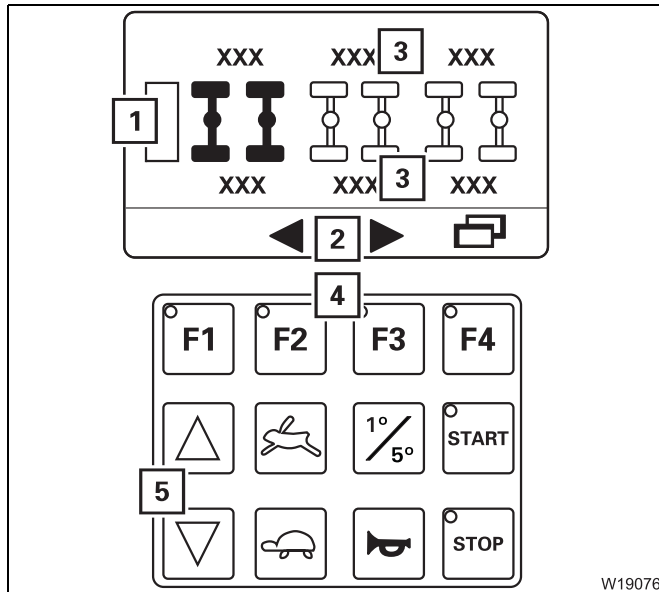

#### Raise axle display

- 1 Selected axle pairs display
- 2 Directional indicator
- 3 Axle load display
- 4 Axle selection
- 5 Raising/lowering axles

➡ p. 13 - 5

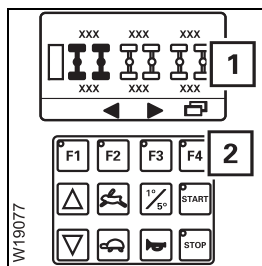

#### Switching on axle raising

Press button (2) until display (1) appears.

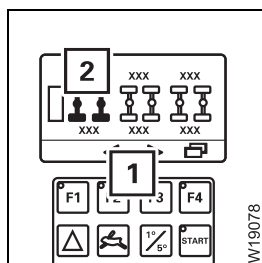

#### Axle selection

##### Pre-select:

Press button (1) – the selected axle pairs (2) or axle lines turn black

Pressing the button (1) again changes the selection.



## 9.2.15

### Slewing gear

▣▣▣▣▶ *Slewing gear*, p. 11 - 96.

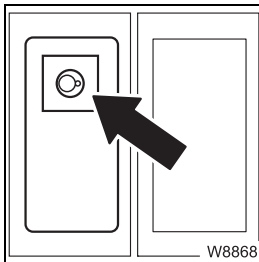

#### Slewing gear on/off

There is a lamp in the button.

- **Press once:**
  - Lamp bright – slewing gear on,  
Slewing gear brake released
  - Lamp dim – slewing gear off  
Slewing gear brake applied

▣▣▣▣▶ p. 11 - 97

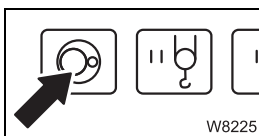

#### Power units display

- **Green:** Slewing gear on
- **Red:** Slewing gear off

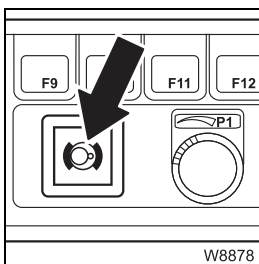

#### Slewing gear brake applied/released

- **On:** Slewing gear brake applied
- **Off:** Slewing gear brake released

▣▣▣▣▶ p. 11 - 97

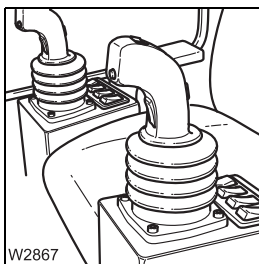

#### Left control lever

The counterweight lifting cylinders are retracted.

- **To the left:** Slew to the left
- **To the right:** Slew to the right

▣▣▣▣▶ p. 11 - 97



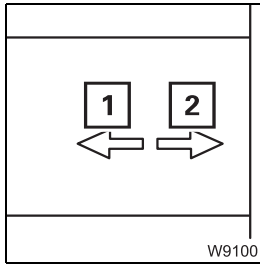

### Teleautomation direction display

- 1 On:** Start teleautomation with *Extending*
- 2 On:** Start teleautomation with *Retracting*

Flashing = control lever movement incorrect

▣▣▣▣ p. 11 - 89

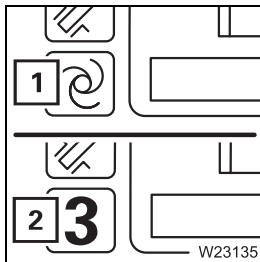

### Teleautomation on/manual telescoping on

- 1 Teleautomation on**  
▣▣▣▣ *Telescoping with teleautomation*, p. 11 - 89
- 2 Manual telescoping on**  
▣▣▣▣ *Manual telescoping*, p. 11 - 77

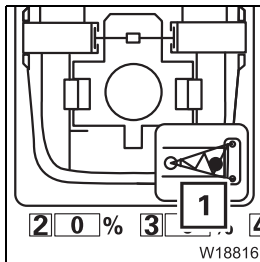

### Lattice extension position display

- 1 - Lights up red:** Retracting/extending blocked
  - Off:** Retracting/extending released
- p. 11 - 76

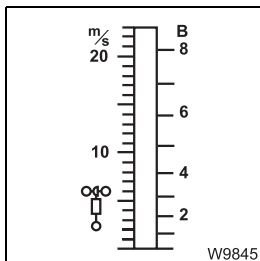

### Anemometer display

Same as in main menu; ▣▣▣▣ p. 9 - 73.



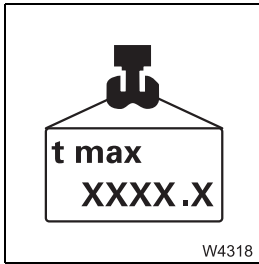

### Maximum load display

Short description with *Monitoring* submenu; p. 9 - 104.

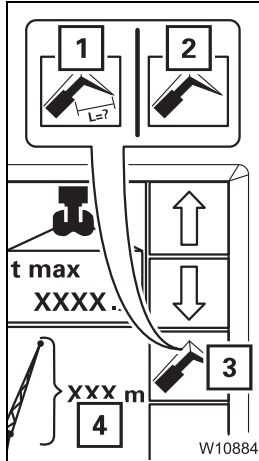

### Boom system entry

- **Input mode on:**
  - For boom system: Press button (3) until symbol (2) is green
  - For length and angle of lattice extension<sup>1)</sup>: Press button (3) until symbol (1) is green
- **Input:** In input mode, press button (3) once – next length on display (4)

p. 11 - 24

<sup>1)</sup> Lattice extension – inclinable

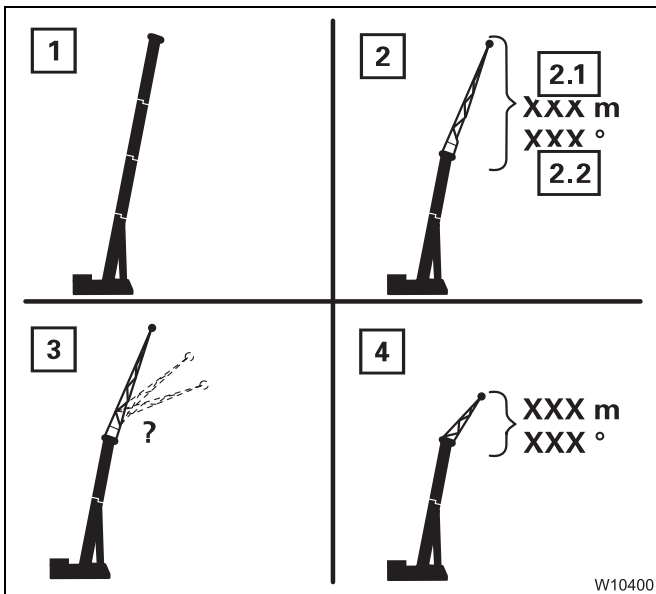

### Boom system display

Boom system for displayed RCL code,

- 1 Main boom/auxiliary single-sheave boom top
- 2 Lattice extension
  - 2.1 Length
  - 2.2 Angle<sup>1)</sup>
- 3 RCL rigging code for angling entered<sup>1)</sup>
- 4 Heavy load lattice extension

p. 11 - 26

<sup>1)</sup> Lattice extension – inclinable



## 9.2.22

### Lighting, windscreen wiper/washing system

#### Lighting

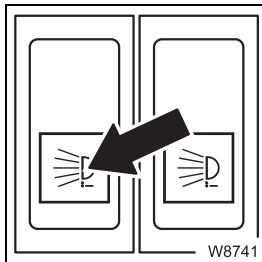

#### Spotlight sockets on/off

- **To switch on:** Press down – voltage on (both sockets)
- **To switch off:** Press up – voltage off (both sockets)

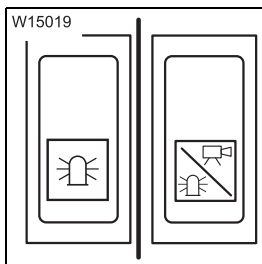

#### Air traffic control light/camera on/off

- **To switch on:** Press down – voltage on socket switched on/camera on
- **To switch off:** Press up – voltage on, socket switched off/camera off

➡ p. 12 - 112

➡ *Separate operating instructions*

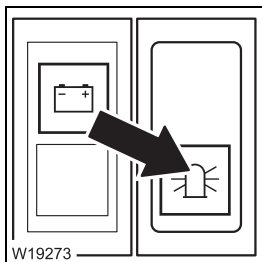

#### Rotating beacons on/off

- **To switch on:** Push down – lamp in the button on
- **To switch off:** Push up – lamp in the button off



## 10 Starting/switching off the engine – for crane operation

<b>10.1</b>	<b>Starting the engine – from the crane cab</b> . . . . .	10 - 1
10.1.1	CHECKLIST: Starting the engine . . . . .	10 - 1
10.1.2	CHECKLIST: At low temperatures . . . . .	10 - 4
10.1.3	Refuel . . . . .	10 - 4
10.1.4	Checks before starting the engine . . . . .	10 - 7
10.1.5	Switch on the ignition . . . . .	10 - 8
10.1.6	Lamp test / switching state alignment . . . . .	10 - 9
10.1.7	Adjusting display brightness . . . . .	10 - 11
10.1.8	Starting the engine . . . . .	10 - 12
10.1.9	Checks after starting the engine . . . . .	10 - 14
10.1.10	Monitoring submenu . . . . .	10 - 15
10.1.11	Setting idling speed . . . . .	10 - 16
10.1.12	Override torque reduction . . . . .	10 - 17
<b>10.2</b>	<b>Starting the engine – with the hand-held control</b> . . . . .	10 - 19
<b>10.3</b>	<b>Switching off the engine.</b> . . . . .	10 - 21
10.3.1	During normal operation, with the ignition lock/with the hand-held control .	10 - 21
10.3.2	In emergencies, with the emergency stop switches . . . . .	10 - 22
<b>10.4</b>	<b>Air intake inhibitor.</b> . . . . .	10 - 23

## 10.1.6

### Lamp test / switching state alignment

#### Lamp test

After the ignition has been switched on, a lamp test is performed.

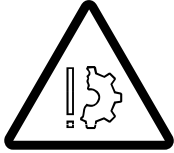

#### Risk of accidents due to faulty lamps!

The lamps that are used to provide warnings and information during operation light up for control purposes whenever the ignition is switched on. Always perform the following lamp tests and immediately replace faulty lamps or have them replaced!

This prevents accidents and damage caused by detecting malfunctions too late.

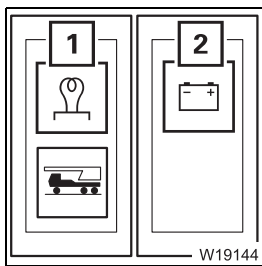

- Check that the lamps (1) and (2) light up briefly.

If the specified time is insufficient, switch on the ignition again.

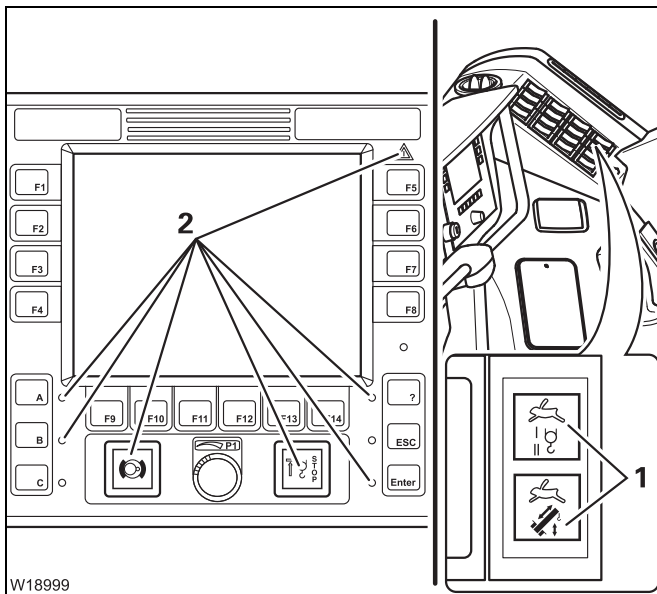

- Check whether lamps (1) and (2) light up briefly.

If one or more lamps do not light up, refer to **Manitowoc Crane Care**.

If the specified time is insufficient, you can perform the lamp test again as follows.



## 10.2

## Starting the engine – with the hand-held control

### Prerequisites

You can only start the engine for crane operation if

- The bridging plug is inserted in all unneeded sockets;  p. 10 - 8 and
- The ignition in the driver's cab is switched off.

### Starting the engine

All checks required before starting the engine must be carried out;  
 p. 10 - 1.

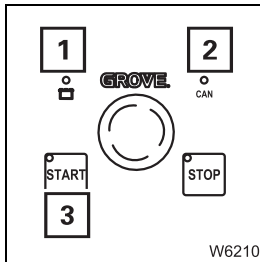

- Wait until the lamps (1) and (2) illuminate.

If the lamp (2) does not go on or flash after approx. 20 seconds, there is a malfunction;  p. 14 - 24.

Press the (3) button once – the engine starts.



If the hand-held control is connected to the superstructure, you cannot drive the power units from the crane cab.

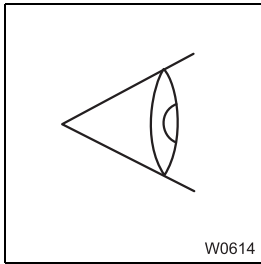

- 9. Check**
- RCL,
  - lifting limit switch,
  - seat contact switch and dead man's switch,
  - emergency stop switch,
- for correct operation. Have faulty units repaired; p. 11 - 9.

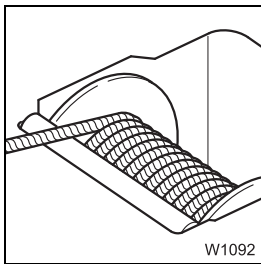

- 10. Check the position of the hoist ropes;** p. 11 - 6.

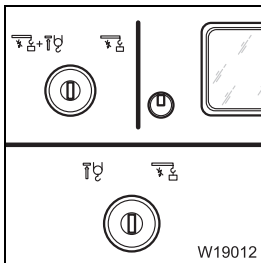

- 11. Remove the keys from the key-operated *Override* switches;**  
 p. 11 - 40.

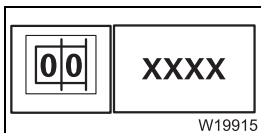

- 12. Compare current rigging mode to display on RCL – enter current rigging mode if necessary;** p. 11 - 23.



- 13. Compare current reeving of hoist used against the display on the RCL – enter current reeving if necessary;** p. 11 - 29.

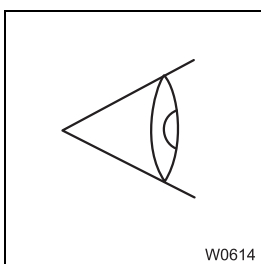

- 14. Check telescoping;** *Checks before starting work*, p. 11 - 73.

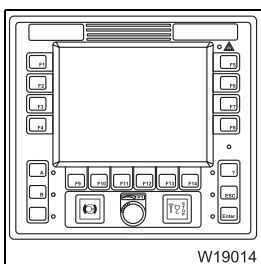

- 15. Perform lamp test on the RCL;** p. 11 - 20.



## 11.1.6 Preheating the hydraulic oil



It may take some time for the solenoid valves to be switched or the power units may be started abruptly if the oil is cold.

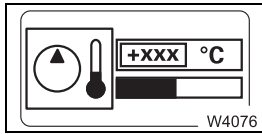

The current hydraulic oil temperature is displayed in the *Monitoring* sub-menu. To open the submenu; p. 10 - 15.

### - Above 10 °C

Crane operation with load is permissible without speed restriction.

### - From 0 °C to 10 °C

- To preheat, carry out crane movements with loads only in normal operation mode, at average engine speed and at average operating speed.

### - From 0 °C to -15 °C

- To preheat, only carry out crane movements **without a load**. Only operate at normal speed, at medium engine speed and medium working speed.

### - Below -15 °C

Crane movements are not permitted. Preheat the hydraulic oil first.

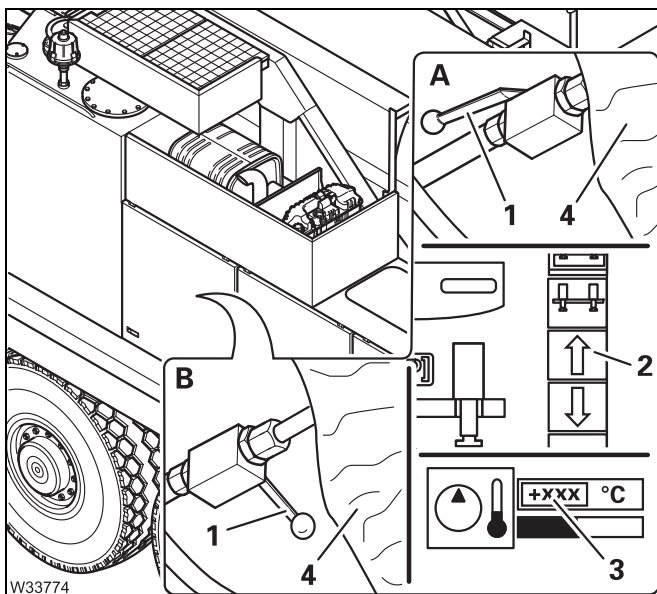

### (A) – Preheating

- Open the valve – lever (1) parallel to the line.
- Press the button (2) and retract the lifting cylinders to the full extent at low engine speed; p. 12 - 76.

The hydraulic oil has been preheated when display (3) shows a temperature of at least 10 °C .

### (B) – Before crane operation

Do not touch the hot exhaust system (4).

- Close the valve – lever (1) at right angles to the line.



Operate all crane functions at least twice after preheating (hydraulic oil temperature above 10 °C) in order to remove the cold oil from all parts of the hydraulic system.

## 11.2.2 Enter rigging mode

For a complete rigging mode input, you must enter, confirm and accept the rigging mode and the reeving.

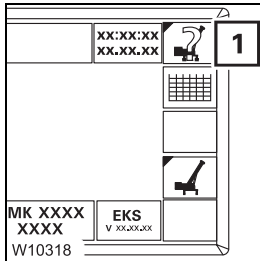

### Opening the submenu

- If necessary, open the main menu **Esc** and press the button (1) once.

The **Esc** button is only active if all crane movements have been stopped.

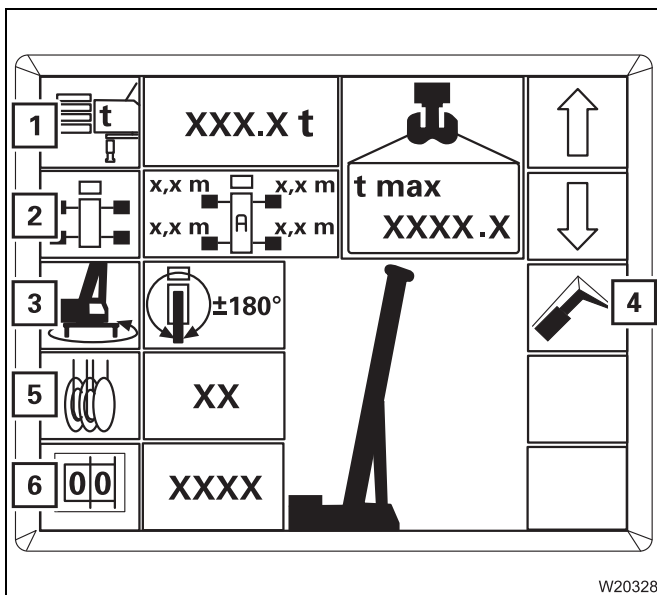

The *Enter rigging mode* submenu opens.

There are two ways of entering the current rigging mode.

- **Either** enter the individual components (1) to (5) one after the other.
- **Or** enter the RCL code (6) and the reeving (5)

Then you must confirm and accept the newly entered rigging mode.

The following section describes the input procedure based on the individual components. If you want to enter the rigging mode based on the RCL code; **Enter the RCL code**, p. 11 - 28.



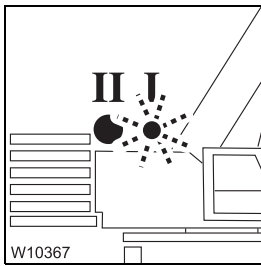

### Example of how to switch over the display

The load should be raised with the main hoist, for example. However, lamp **II** for the auxiliary hoist lights up and lamp **I** for the main hoist flashes.

Switch over the display as follows:

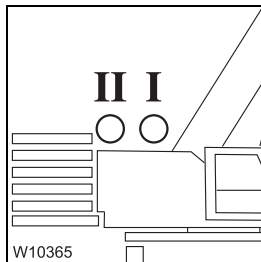

- Switch off both hoists. The lamps **I** and **II** go out.

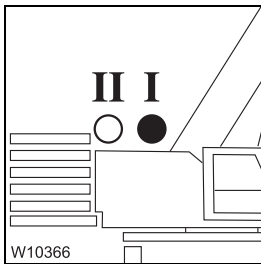

- Switch on the main hoist.
- Now the lamp **I** for the main hoist is on.

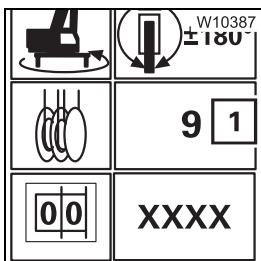

The display **(1)** shows the last entered reeving value for the main hoist, e.g. **9**.

If no reeving has been entered yet, the RCL selects reeving **1**.

- If necessary, enter the current reeving; ►►► p. 11 - 29.



### Risk of accidents due to an incorrectly set RCL!

After switching over the hoists, always check whether the displayed reeving value corresponds to the current reeving value of the displayed hoist and, if necessary, enter the current reeving value.

In this way, you can prevent the RCL from making calculations based on an incorrect reeving value and the truck crane from becoming overloaded or from overturning.

### Raising after RCL shutdown

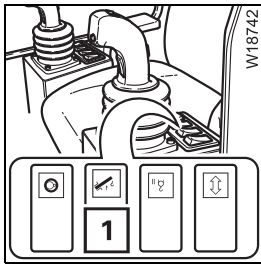

You can re-enable raising with the switch (1) in order to leave the shutdown range.  
The speed will then be reduced to 50%.

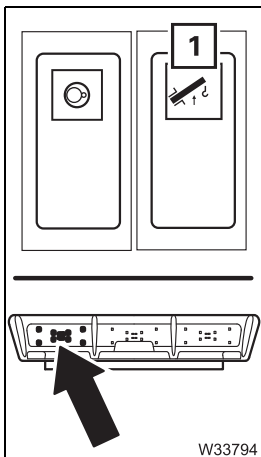

### Raise main boom

- Push the button (1) up once.
  - Raising is enabled.  
The RCL will show an information code;  p. 11 - 46.
  - The status display will flash green.
- Raise the main boom with the control lever until the degree of utilisation is less than 100%.  
The crane movements will then be enabled again.



The raising of the main boom will be shut down if the main boom angle is too great. Then all you can do is set the load down.

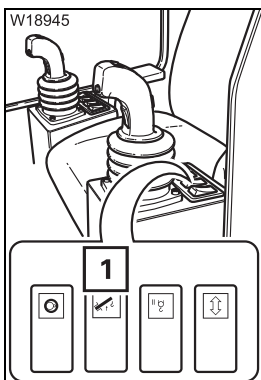

- If the degree of utilisation is over 100%, you can cancel the function by:
- press button (1) up again, or
  - switch off the ignition.





## 11.3.2



### Permissible slewing ranges and working positions

The following ranges are permissible for crane operation according to the *Lifting capacity table*.

#### 360° slewing range



- Support the truck crane with the outrigger span required according to the *Lifting capacity table*.
- Enter an RCL code for the 360° slewing range according to the *Lifting capacity table*;  Enter rigging mode, p. 11 - 23.
- Rig a counterweight combination that is no larger than that permitted for the rigged outrigger span. Slewing with a rigged counterweight is not permitted with all outrigger spans;  *Slewing with rigged counterweight*, p. 12 - 83.
- Slewing is not permissible if the truck crane is free-on-wheels;  *Main hoist*, p. 11 - 54.

#### Working position 0° to the rear

- Support the truck crane with the outrigger span required according to the *Lifting capacity table*.
- Slew the superstructure to the rear into the 0° position;  *Braking the slewing movement*, p. 11 - 99.
- Switch off the slewing gear;  p. 11 - 100.
- Enter an RCL code for the 0° to the rear according to *Lifting capacity table*;  Enter rigging mode, p. 11 - 23.  
The RCL will only accept this code if the slewing gear has been switched off and the superstructure is in the 0° position.



All slewing operations are disabled if an RCL code is entered for the 0° to the rear working position. An RCL shutdown will be triggered if you switch on the slewing gear. To acknowledge the shutdown, you must:

- Either shut down the slewing gear
- Or, if slewing is permissible with the rigged counterweight ( p. 12 - 83), set down the load and enter an RCL code for the 360° slewing range.
- Observe the additional information if the truck crane is free on wheels;  *Main hoist*, p. 11 - 54.

#### 180° to the front rigging position

The same lifting capacity tables and RCL codes apply to this position as to the 360° slewing range.

## raising and lowering

You can adjust the sensitivity of the control levers to the operating conditions;  *Setting the characteristic curves for the control levers*, p. 11 - 106.



### Risk of accident due to unexpected crane movements!

If assigned more than one function, check that the *Derricking* control lever function is switched on before you move the control lever for derricking. This prevents accidents due to unexpected crane movements.

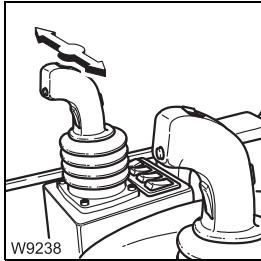

#### Lowering:

- Push the control lever to the right – the main boom is lowered.

#### Raising:

- Push the control lever to the left – the main boom is raised.

You can regulate the speed by moving the control lever and changing the engine speed with the accelerator.



The maximum derricking speed will automatically be reduced as the system length is increased. If you now reduce the working radius (e.g. by retracting the telescoping), the derricking speed will automatically be increased again.

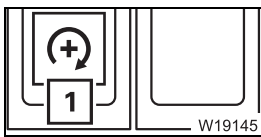

You can set the desired engine speed (idling speed) with button (1);  p. 10 - 16.

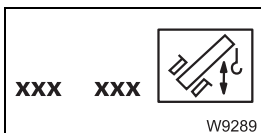

You can limit the maximum derricking speed;  p. 11 - 105.

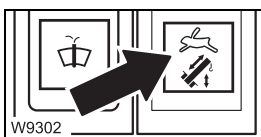

You can switch on high-speed mode for a higher speed;  p. 11 - 94.



## Checks before starting work

When the ignition is turned on, ECOS registers the displayed telescoping status from the current status of the telescoping mechanism and the previously saved locking and unlocking procedures.

**Normally**, ECOS detects differences between the current and the displayed telescoping and displays the corresponding error message;  *Telescoping mechanism error messages*, p. 14 - 19.

If a **malfunction** results in values being deleted, ECOS can no longer calculate the current telescoping and will not issue an error message.



### Risk of damage to the telescoping mechanism!

Before the first telescoping, always check whether the *ECOS* display is showing the current telescoping.

This prevents the telescoping mechanism from being damaged when telescoping.

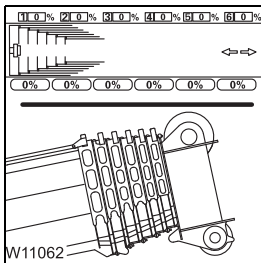

- Before telescoping the first boom, compare the telescoping shown on the *ECOS* display with the current telescoping.

If the current telescope status is not correctly displayed, enter the current telescope status;  *Entering the current telescoping*, p. 14 - 57.



### Lock telescoping cylinder

The telescoping cylinder must be locked to a telescopic section so that the telescopic section can be telescoped.

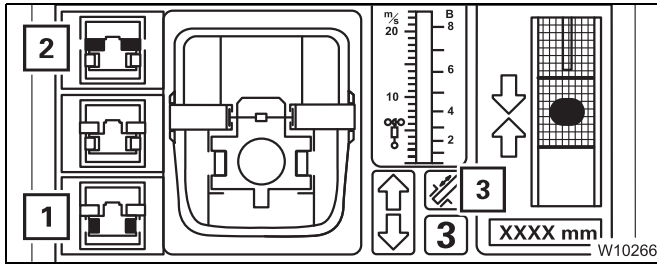

#### Prerequisites

- Telescoping mechanism on – symbol (3) is green
- Telescopic section locked – symbol (2) is grey
- Telescoping cylinder unlocked – symbol (1) is yellow

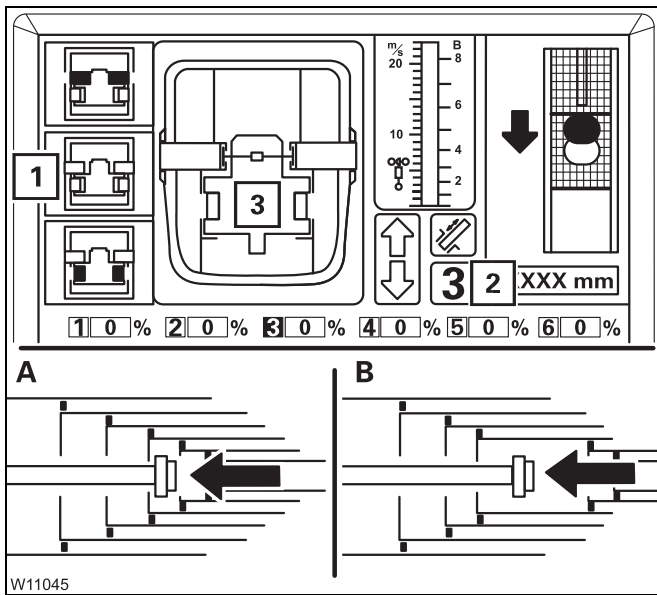

#### To select lock

- Move the telescoping cylinder to the desired locking point, e. g. to telescopic section III.

Wait until the display (2):

- (A) shows the desired telescopic section or
- (B) shows no telescopic section and the desired locking point is reached next.
- Press the button (1) once.  
Symbol (1) will flash – *Lock telescoping cylinder* is selected.

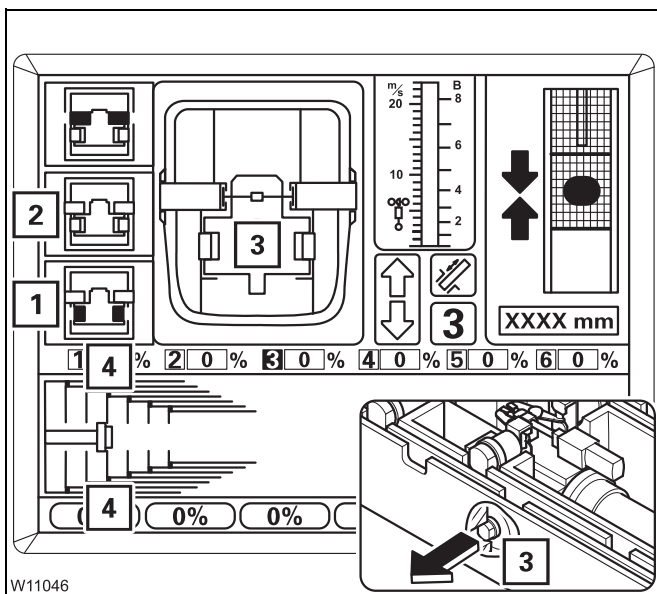

#### Lock the telescoping cylinder

- Move the control lever until locking is complete.

The locking pins (3) extend at the locking point.

- **Yellow:** Intermediate position
- **Green:** Locked

In *Locked* position:

- Symbol (1) is yellow,
- Symbol (2) is grey,
- The locking pins (4) are green.



### Telescoping the main boom when horizontal

- Derrick the main boom to the horizontal position as described in section *Lowering the main boom to a horizontal position*;  p. 11 - 65.

The RCL will automatically switch to the corresponding rigging table. This table specifies the maximum permissible telescoping at which extending will be switched off (shutdown values  *Lifting capacity table*).

- Set down the load.
- Extend the main boom only until the RCL switches off the extension procedure.



If you continue to extend the main boom after an RCL shutdown, you may enter ranges in which you can neither perform retraction operations nor raise the boom.

## 11.4

### Settings and displays for crane operation

This section only describes settings and displays needed during crane operation. Operating elements that can be assigned to other procedures are described with the corresponding procedures.

#### 11.4.1

#### Inclining the crane cab

With the appropriate equipment, you can incline the crane cab to the rear in order to attain a better sitting position when working at great heights.



##### **Risk of accidents due to objects overturning in the crane cab!**

Close the crane cab door before inclining and remove all loose objects (e.g. bottles) from the crane cab.

This prevents objects from tipping over, the crane cab door opening by itself, and unintended operational accidents caused by fright.

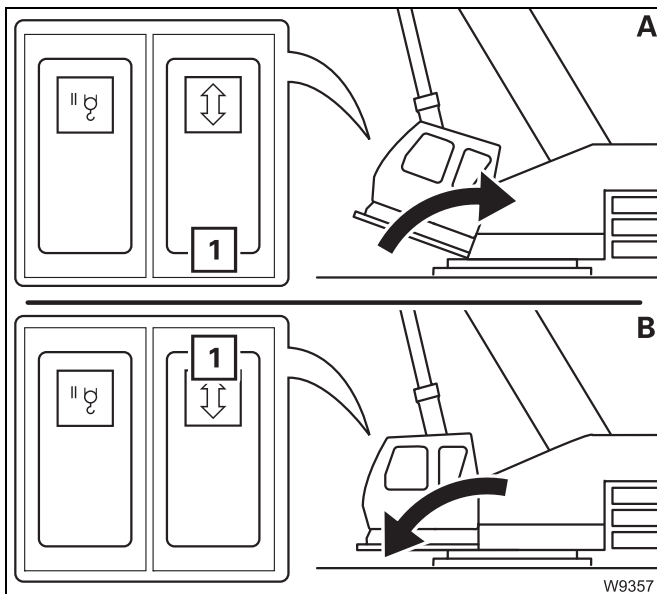

##### **(A) – Incline to the rear**

- Close the crane cab door.
- Press button **(1)** down.

##### **(B) – Incline to the front**

- Close the crane cab door.
- Press button **(1)** up.

The crane cab will tilt as long as you hold the button down or until its end position is reached.

#### 11.4.2

#### Setting idling speed

▣▣▣▣ *Setting idling speed*, p. 10 - 16.

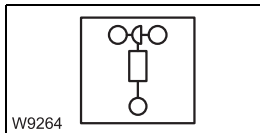

### Anemometer not connected

- Connect the anemometer to the electrical power supply; p. 12 - 112.

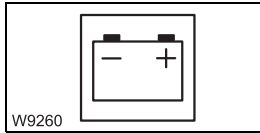

### Voltage monitoring

The voltage in the superstructure electrical system is too high or too low. Display of the current voltage; p. 10 - 15, p. 4 - 20.

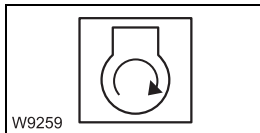

### Air intake inhibitor triggered

The air intake inhibitor was triggered because the maximum permissible engine speed was exceeded. It is possible to start the engine only after the air intake inhibitor has been released manually; p. 10 - 23, p. 4 - 25.

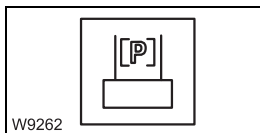

### Pre-tension counterweight

The pre-tensioning pressure on the counterweight has dropped too much.

- Pre-charge the counterweight; p. 12 - 77.

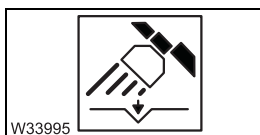

### Pivoting the spotlights

The spotlights can collide with the carrier during derricking; p. 11 - 108.

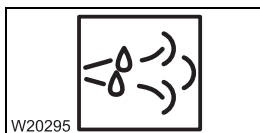

### Refilling carbamide

The carbamide tank is only filled up to a level of approx. 5%.

- Refuel before the carbamide is used up; p. 10 - 6.

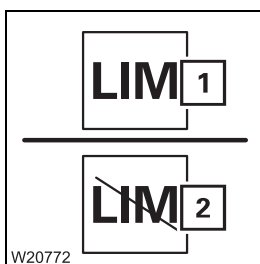

### Torque reduction

The carbamide tank is almost empty. The engine torque has been reduced by the engine control system – symbol (1).

### Override torque reduction

- You can override this torque reduction – Symbol (2); p. 10 - 17.



## Deleting points

You can delete selected, individual points or delete all points at once.

**A**

	$\alpha$ [°]	R[m]
1 +	2.0	20.0
2 +	90.0	20.0
3 +	140.0	20.0
<b>4</b> +	0.0	0.0
5 +	0.0	0.0
6 +	0.0	0.0
7 +	0.0	0.0
8 +	0.0	0.0
-	90.0	20.0

**B**

	$\alpha$ [°]	R[m]
1 +	0.0	0.0
2 +	0.0	0.0
3 +	0.0	0.0
<b>4</b> +	0.0	0.0
5 +	0.0	0.0
6 +	0.0	0.0
7 +	0.0	0.0
8 +	0.0	0.0
-	90.0	20.0

W25926

### (A) – Selected points

- Press the button (1) once.

The selected point will be deleted, e.g. point (4) – point data 0.0.

### (B) – All points

- Press button (2) once – symbol (3) will appear.

You can cancel the process by pressing button (4).

- Press button (5) once – all points will be deleted.

## 11.7.2 Air-conditioning system

You can use the air-conditioning system to cool and dry the air in the crane cab.

### Information

Do not cool the air in the crane cab too much. The difference between the outside temperature and the inside temperature should be at the most 10 °C to 14 °C. If the cooling is too severe, you may frequently feel physically uncomfortable, albeit mostly only after you leave the cool environment.

Avoid having cold air blowing directly on to your body.

When using recirculated air, you should switch over to fresh air mode to ensure a fresh supply of oxygen at the same time. Adjust the cooling output to your actual needs:



If the truck crane has been exposed to strong sunlight for a long period of time, for example, the air-conditioning system should initially be operated at the highest blower level with the engine running.

The door or at least the windows should be left open for a short while to thoroughly air the cab. The cooling-down procedure can be accelerated by increasing the engine speed.

If the air-conditioning system is operated continuously, close the windows and doors to ensure sufficient cooling.

Once the inside temperature has reached the desired temperature, set the fan to a lower level.

### Switching on/off

- Start the engine. The air-conditioning system operates only when the engine is running
- Switch off the auxiliary heaters.
  - Auxiliary water heater;  p. 11 - 141,
  - Auxiliary air heater;  p. 11 - 142.

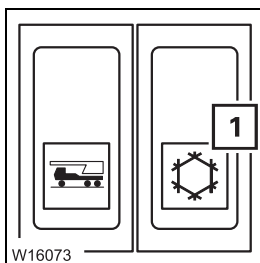

- **To switch on:** • Press switch (1) down
- **To switch off:** • Press switch (1) up



## Temperature

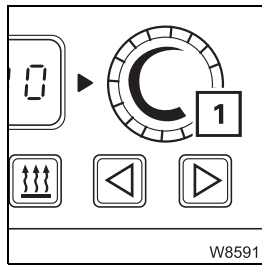

You can preselect a temperature for the crane cab. The preselected temperature is automatically set and maintained.

### Increasing the temperature:

- Turn the switch (1) clockwise.

### Reducing the temperature:

- Turn the switch (1) anti-clockwise.

The higher the selected temperature is, the faster the fan of the auxiliary heater runs.

## Switching off

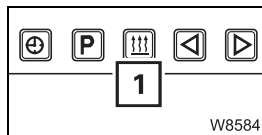

You can switch off the auxiliary heater manually at any time.

- Press the button (1) once. The auxiliary heater is switched off immediately.

## Other functions

The auxiliary air heater has the same functions as the auxiliary water heater.

- Setting the time/day ▶▶▶▶ p. 11 - 138
- Storing the heating start ▶▶▶▶ p. 11 - 138
- Switching heating start on/off ▶▶▶▶ p. 11 - 140
- Setting the heating period ▶▶▶▶ p. 11 - 139
- Setting the remaining time ▶▶▶▶ p. 11 - 141

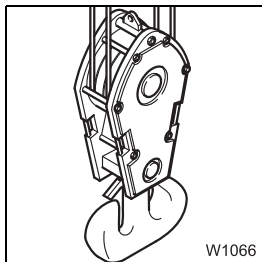

W1066

### 6. Depending on transport:

- Attach the hook block to the bumper; ■■■▶ p. 12 - 86 or
- Set down the hook block and unreeve the hoist rope;
  - ▶ *Setting down the hook block*, p. 12 - 88,
  - ▶ *Unreeving hoist rope*, p. 12 - 96.

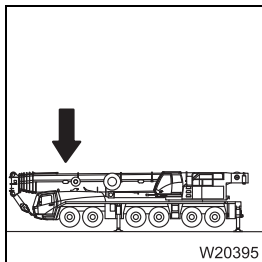

W20395

### 7. For on-road driving without trailer:

- Turn the superstructure to the 180° position to the front with the RCL adjusted accordingly,
- Place the main boom on the boom rest.

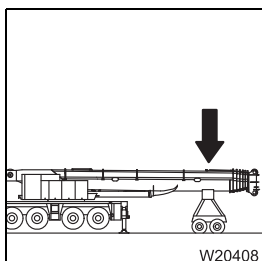

W20408

### 8. For on-road driving with a trailer:

- Set down the superstructure on a trailer with the RCL adjusted accordingly and switch on the boom floating position; ■■■▶ p. 6 - 13,
- Switch on the slewing gear freewheel; ■■■▶ p. 6 - 12,
- If necessary, switch on the boom pre-tensioning; ■■■▶ p. 6 - 14,
- Switching off the houselock; ■■■▶ p. 11 - 15.

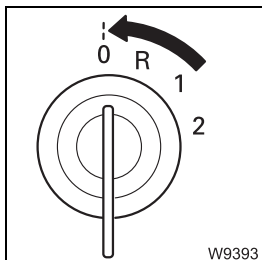

W9393

### 9. Switch off the engine for crane operation; ■■■▶ p. 10 - 21.

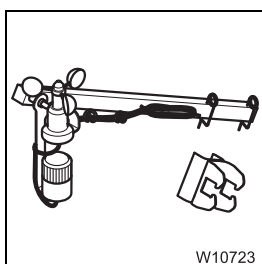



W10723

### 10. Remove anemometer and the air traffic control light; ■■■▶ p. 12 - 112.



## 12.3 Rigging work after driving with a trailer

If the main boom is resting on a trailer (dolly) whilst the truck crane is being driven, you must perform the following before working with the crane:

- switch off the slewing gear freewheel;  p. 12 - 18,
- switch off the boom floating position;  p. 12 - 17,
- if necessary switch off the boom pre-tensioning;  p. 12 - 19.

### 12.3.1 Switching off the boom floating position

You must switch off the boom floating position before you raise the main boom off the trailer.



#### **Risk of accidents from the main boom dropping down!**

Always secure the lever with the padlock after switching off the boom floating position.

This prevents the raised main boom falling down when the lever is actuated.

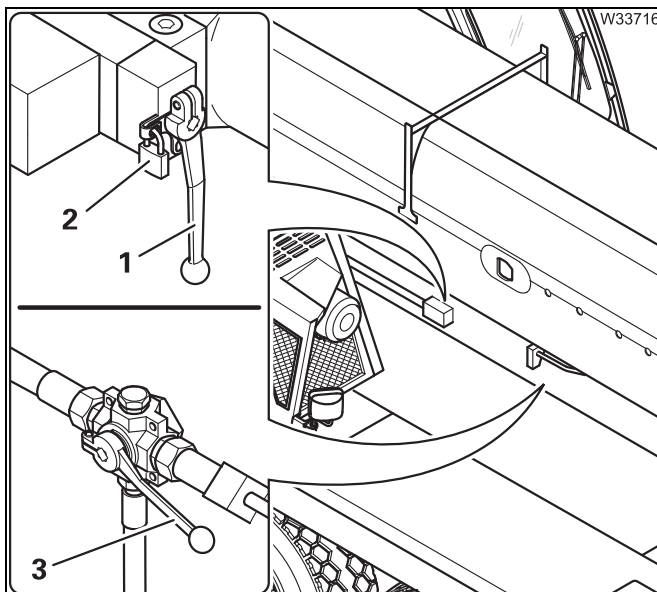

- Remove the padlock (2).
- Switch over valve I – lever (1) vertically down.
- Secure the lever (1) with the padlock (2).
- Switch the valve IV over – lever (3) points forwards.

The boom floating position is now switched off.

## 12.6

## Outriggers



### Danger of crushing from extending outrigger beams!

You may only activate the outriggers if you yourself or a banksman with whom you are in visual contact have an unobstructed view of their movements.

### 12.6.1

### CHECKLIST: Extending the outriggers



This checklist is not a complete operating manual. There are accompanying instructions, which are indicated by cross-references.

**Observe the warnings and safety instructions there!**

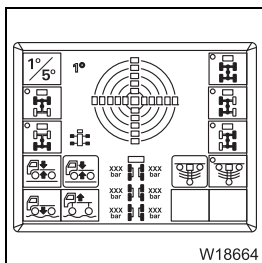

1. Level the truck crane with the level adjustment system and lower it as far as possible; p. 5 - 64.

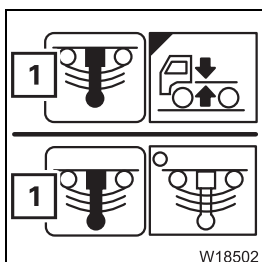

2. Switch off (lock) the suspension.  
The symbol (1) must be **red** (suspension off); p. 5 - 18.

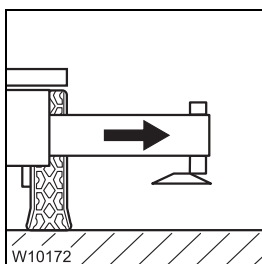

3. Extend all outrigger beams to the required span;
  - Permissible outrigger spans*, p. 12 - 30,
  - Setting the outrigger spans*, p. 12 - 32,
  - Extending/retracting outrigger beams*, p. 12 - 35.

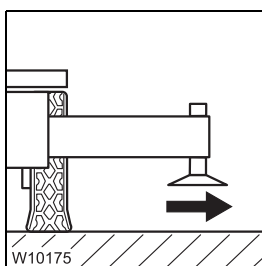

4. Move the outrigger pads into the working position and secure them; p. 12 - 39.



### From the crane cab

The following operating elements are found in the *Outriggers* submenu.

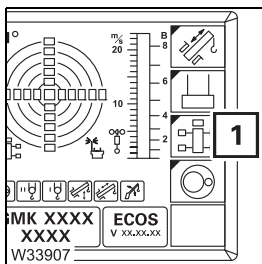

### Opening the submenu

- In the main menu, press button (1) once.  
The *Outriggers* submenu opens.

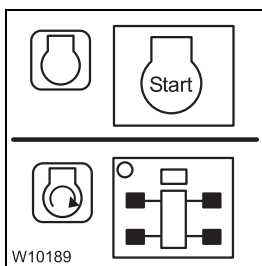

### Start the engine

- Switch the carrier ignition on and start the engine for driving;  
    ▶▶▶ p. 12 - 23.
- Switch off the slewing gear.

### Pre-selecting outriggers



Only pre-select one outrigger. If you pre-select several outriggers, operation of the outriggers is not enabled.

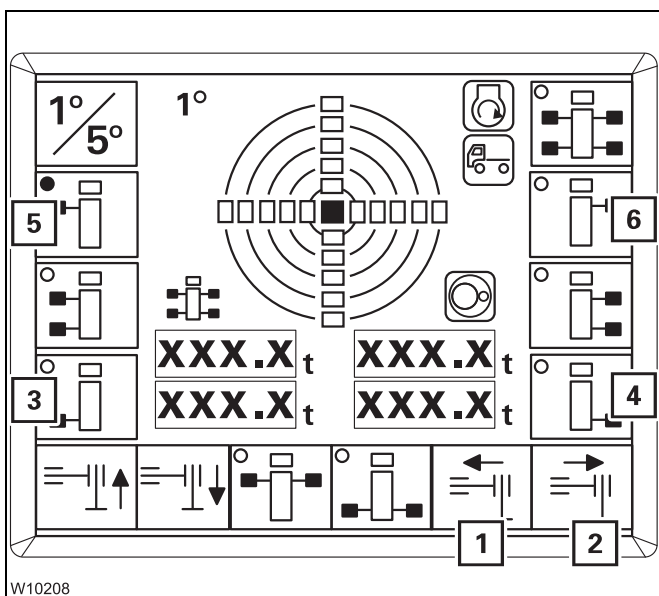

- Press the button once next to the symbol for the desired outrigger.
  - 3 Rear left
  - 4 Rear right
  - 5 Front left
  - 6 Front right

Pre-selection is switched on.

- The dot in the symbol turns **green**, e.g. in symbol (5).
- The symbols (1) and (2) turn **black**.

The pre-selection is switched off after approx. 10 seconds.



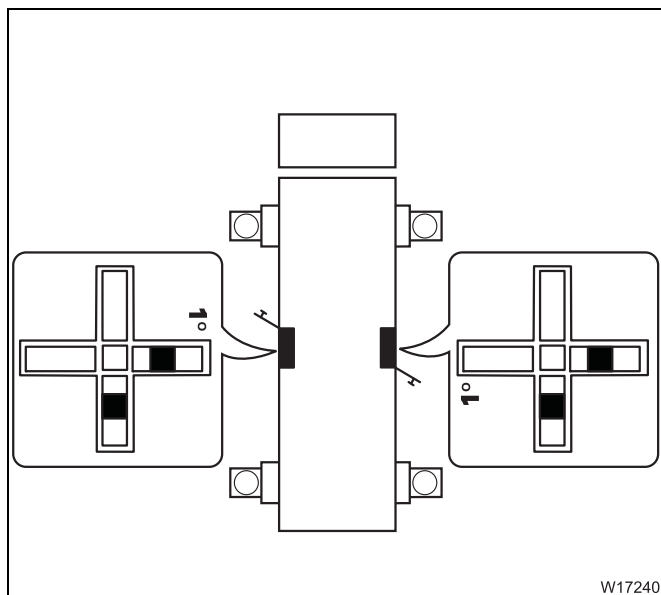

– *Outrigger* control units

The assignment to the carrier corresponds to the top view.

Due to the position of the control units, the displays on both sides differ.

In this example, the carrier would be standing higher to the rear on the right hand side.

**Prerequisites**

The following prerequisites apply to manual and automatic alignment.

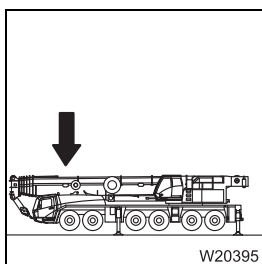

The main boom must be resting on the boom rest.

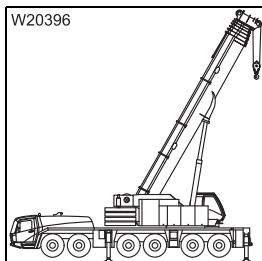

Or

- the main boom must be raised **and**
- the load must have been set down **and**
- the superstructure must be in the 0° or 180° position.



**Risk of overloading the main boom!**

Always slew the superstructure to the 0° or 180° position and set down the load before levelling the truck crane.

In other positions, the deformation of the carrier will distort the indicated inclination and the truck crane will be at an angle. This could cause the boom to become overloaded during crane operation.



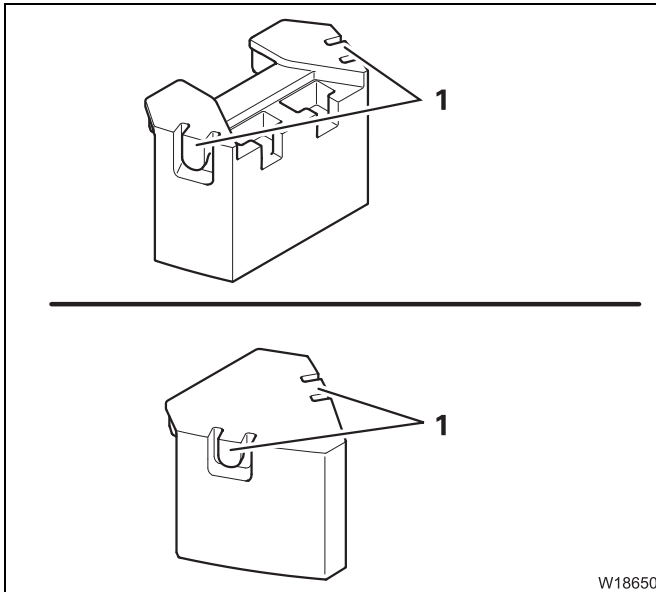

### Slinging points on the blocks

Two slinging points each (1) are on the 9 t and 10 t blocks.

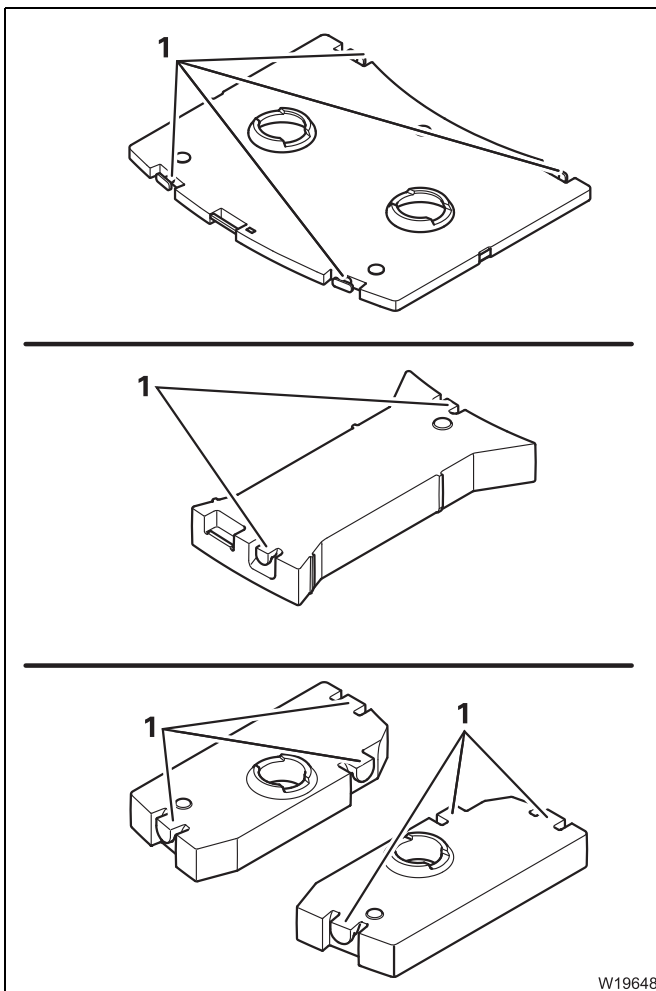

### Slinging points on version B sections

In contrast to version A, there are:

– four slinging points (1) on the 4.75 t section,

– two slinging points (1) on the 4.75 t section,

– three slinging points (1) respectively on the 4.75 t sections.

The diagram shows all counterweight sections in version **A** with additional equipment (4) and (5) with the maximum counterweight mass of 92.5 t.

- The base plate (1) must always be at the bottom.
- The counterweight sections (2) can be exchanged among each other.
- The counterweight section (3) must always be placed on top with the 54.5 t counterweight combination.
- The counterweight blocks (4) can only be attached to the counterweight section (3).
- The counterweight blocks (5) can only be attached to the counterweight blocks (4).

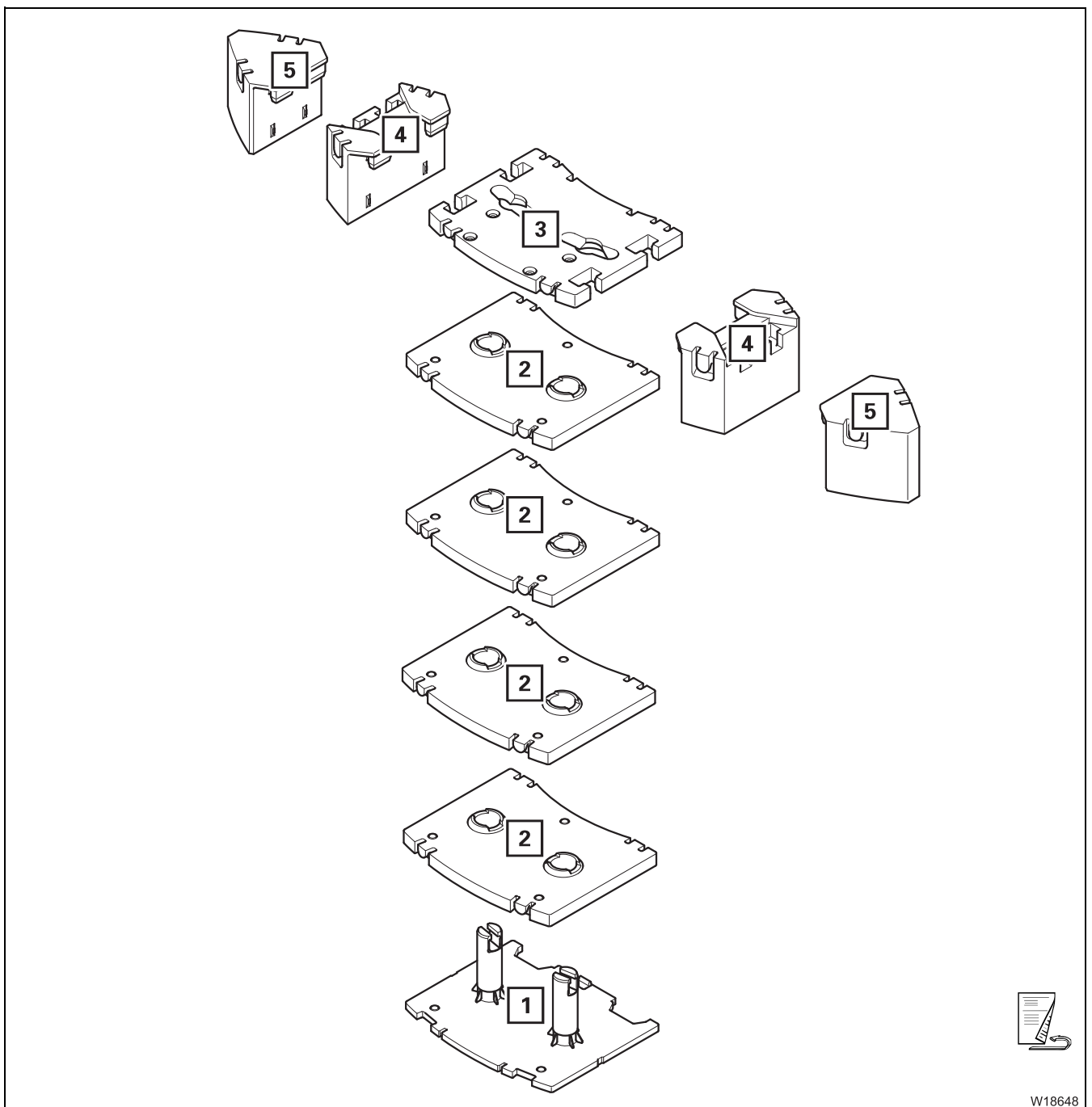

14.03.2018



W18648

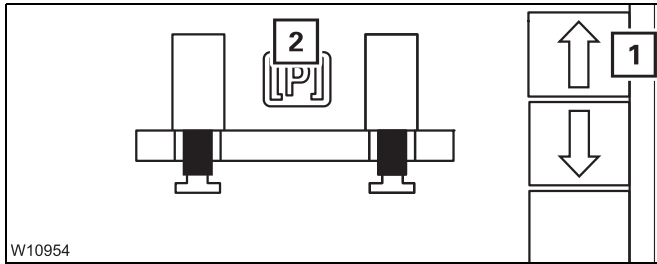

### Pre-tensioning

When the symbol (2) is **red**, you must pre-tension the counterweight.

- Press button (1) until symbol (2) turns **green**.

### Automatic mode rigging

While the automatic mode is being executed, you can always

- **cancel** the automatic mode; *Cancel automatic mode*, p. 12 - 80.
- **interrupt** the automatic mode by letting go of the control lever. After moving the lever in the displayed direction once more, the automatic mode is continued.

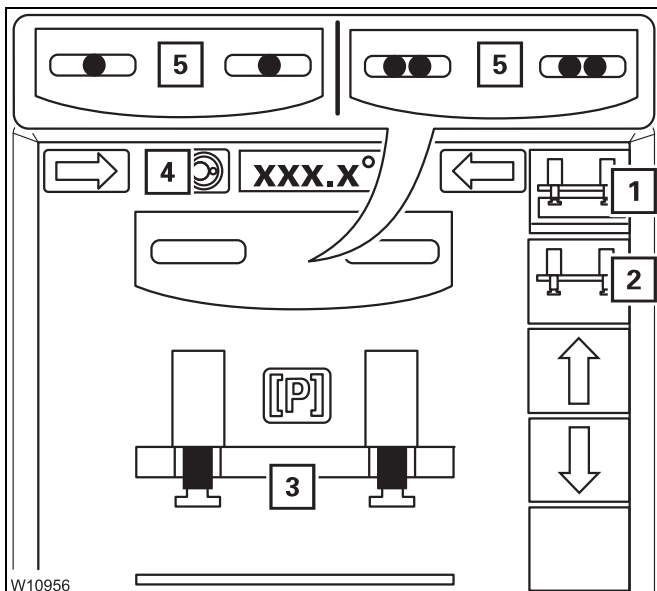

### Prerequisites

- The counterweight combination must be assembled.
- Symbol (2) is **yellow**. If the symbol (1) is yellow; *Correct the rigging mode*, p. 12 - 76.
- The lifting cylinders are fully retracted – display (3).
- The slewing gear must be switched on – symbol (4) **green**.
- The superstructure is in the rigging range – one display (5) **green**.

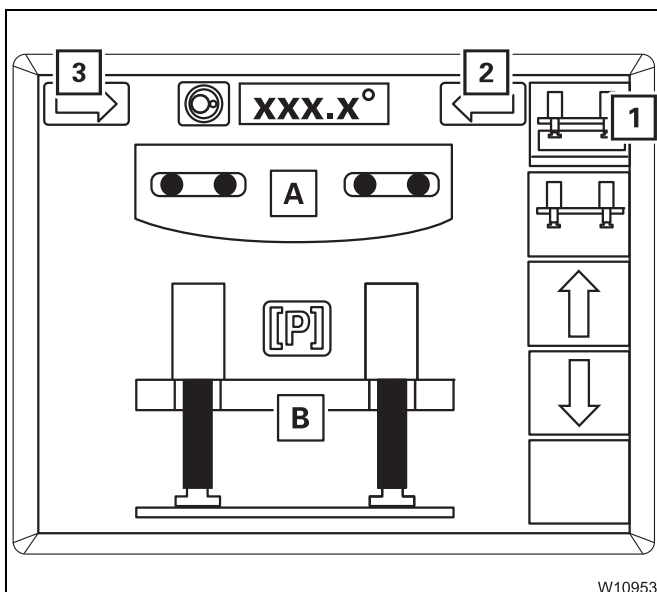

### Switch on automatic mode

- Press the button (1) once – the symbol flashes.

### Execute the automatic mode.

- To slew, move the control lever in the displayed direction (2) or (3) – the automatic mode starts.
  - The superstructure turns into position (A).
  - The lifting cylinders are extended (B).
- Release the control lever.



## 12.8.2

### Hook block on a separate vehicle



#### **Risk of overturning while slewing!**

Always check before slewing whether slewing is permitted in the truck crane's current rigging mode. Correct the rigging mode if necessary;  
▣▣▣▣▶ *Slewing with rigged counterweight*, p. 12 - 83.



#### **Danger of overturning when slewing with an overridden RCL!**

Do not override the RCL before slewing the superstructure.  
Enter an RCL code for the 360° working range if the slewing operation is not released.  
This prevents the superstructure being slewed into impermissible areas and the truck crane tipping over as a result.



#### **Risk of damage to the separate vehicle!**

Raise the hook block from the separate vehicle only when the main boom head is directly above the hook block!  
This prevents the hook block swinging and damaging the separate vehicle.



#### **Risk of damage to the hoist rope!**

To prevent slack rope, do not ease down too much hoist rope when picking up and reeving the hook block!  
Slack rope causes rope loops on the hoist drum, which can result in the load slipping and the hoist rope being damaged!



## 12.8.5

### Possible reeving methods on the main boom

Possible reeving on lattice extensions and the auxiliary single-sheave boom top;  *Operating Instructions Lattice Extension*.



The maximum load bearing capacity of individual hook blocks does not correspond to the maximum load bearing capacity of the GMK6300L-1 together with this hook block. The lifting capacity of the GMK6300L-1 depends on the rope pull, the reeving and friction force. It is lower than the load bearing capacity of the hook block.



Please note that the maximum load bearing capacities already include the weight of the hook block and the lifting gear. You must subtract these weights in order to obtain the actual payload.



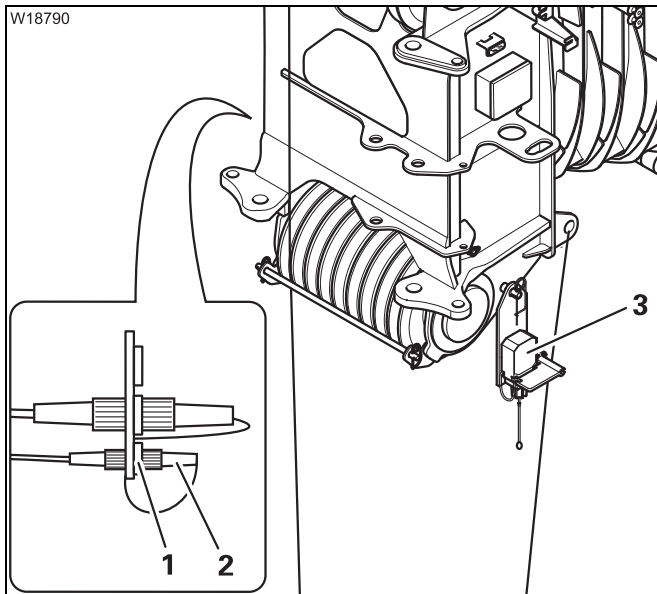

**If only one lifting limit switch has been installed**

- Check whether the bridging plug is in the socket that is not being used.

If, for example, the lifting limit switch (3) is installed on the left, the bridging plug (2) must be in the socket (1) on the right.

Otherwise the movements *Raise hosting gear*, *Telescope out* and *Lower the boom* will be locked.

- Check whether the lock on the lifting limit switch (3) is released; *Removing the lock*, p. 12 - 111.



**Risk of damage if the lifting limit switch is locked!**

The lifting limit switch must not be locked. Remove the lock, if necessary. If the lifting limit switch is locked, the hook block could hit the bottom of the main boom head during the lifting procedure, resulting in damage to the hook block, main boom head and hoist rope.

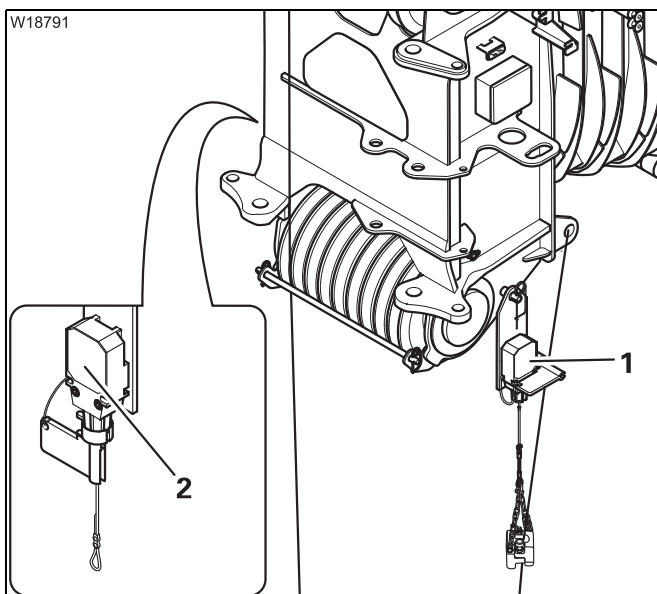

**If two lifting limit switches have been installed**

- Lock the lifting limit switch to which no lifting limit switch weight has been attached.

If the lifting limit switch weight has, for example, been attached to the left lifting limit switch (1), you must lock the right lifting limit switch (2); *Locking*, p. 12 - 110.

Otherwise the movements *Raise hosting gear*, *Telescope out* and *Lower the boom* will be locked.



If two hoist ropes are reeved, you must also use two lifting limit switch weights. In this case, both lifting limit switches must be unlocked; *Removing the lock*, p. 12 - 111.



## 12.9.2 Cameras for crane operation

### Cameras on the hoists

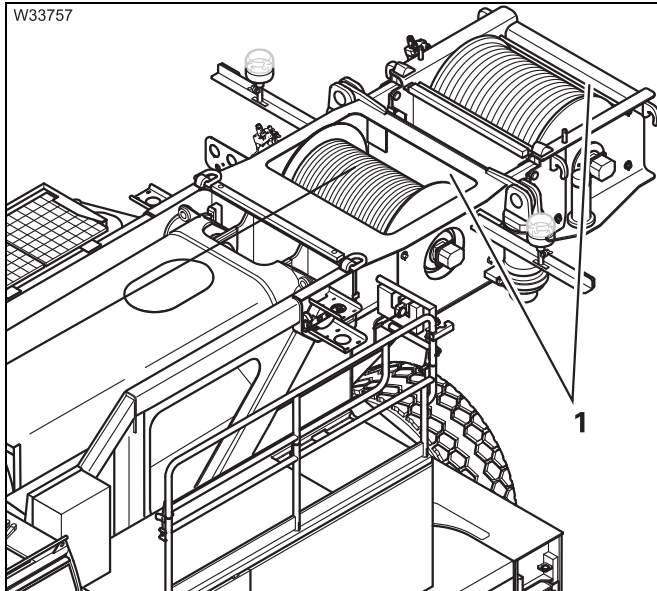

A camera can be found on both the main and auxiliary hoist (1).

- Clean the camera lens if necessary.

### Camera on main boom

For crane operation you have to install the camera and switch it on.

For on-road driving, you have to switch the camera off again and remove it.

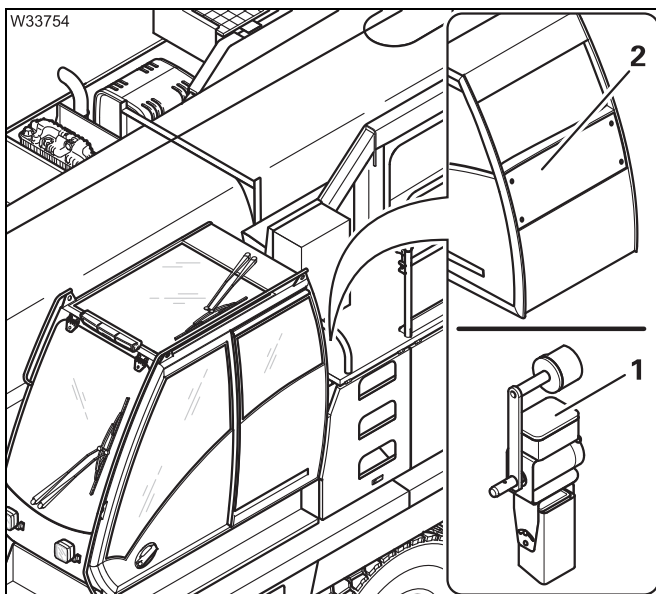

The camera (1) may only be installed on a truck crane equipped with the appropriate receiver (2). The camera and receiver are coordinated and identified with the same number on the model plate.

- Before installation, compare the numbers on the model plates.



# 13

## Driving with a rigged truck crane

This section describes driving the truck crane with the counterweight rigged. If a lattice extension is rigged as well;  *Operating Instructions Lattice Extension*.



### **Risk of accidents due to partially obstructed view of the truck crane!**

When driving the truck crane, always stay in visual or radio contact with a banksman who can observe the parts you are unable to see, e.g. the raised main boom in  $0^\circ$  to the rear.



### **Risk of overturning by slewing the superstructure!**

When driving the rigged truck crane, the slewing gear must be switched off – slewing gear brake engaged. The turntable must be locked.



### **Risk of accidents when driving with a lifted load!**

Driving the truck crane with a load lifted is prohibited. Always set down the load prior to driving the truck crane and secure the hook block so it cannot swing.

## 13.1

### Driving path

The route must be level. Uneven surfaces cannot be compensated with the level adjustment system.

The entire route must be level. The rigging modes and axle loads specified in this chapter only for driving distances which are free of inclines in longitudinal and lateral direction.

The ground must be stable enough to bear the axle loads.

If the surface pressure of the tyres exceeds the permissible load on the ground, the surface area of the tyres must be increased by packing stable material (e.g. wooden planks).

## Switching on

In this section, combined operation is switched on while the engine for driving is turned off. You can also first start the engine for driving from the crane cab.

- If required, open the main menu  in the crane cab.

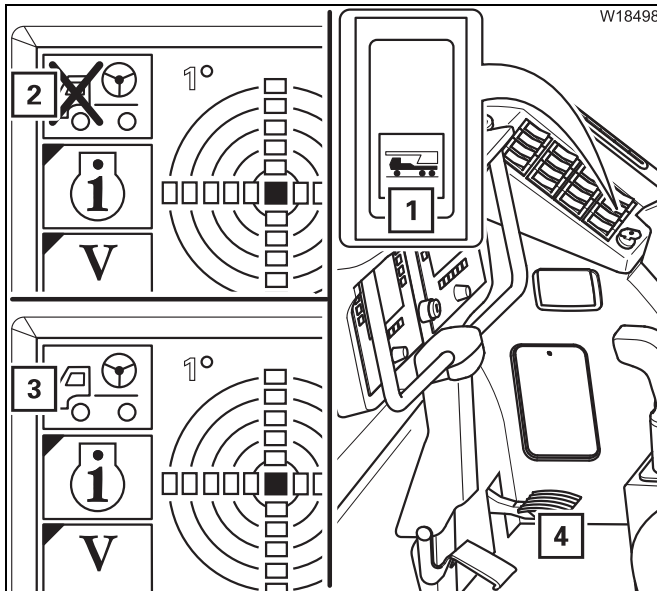

- Press the **(1)** button **down** once.
  - Lamp **(1)** flashes – carrier ignition on.
  - Symbol **(2)** **red** – button **(2)** active.
- Press the button **(2)** once.
  - Symbol **(3)** **green** – combined operation on.
  - The engine for driving can now only be started from the driver's cab.
  - Button **(3)** and brake pedal **(4)** disabled.

## Switching off

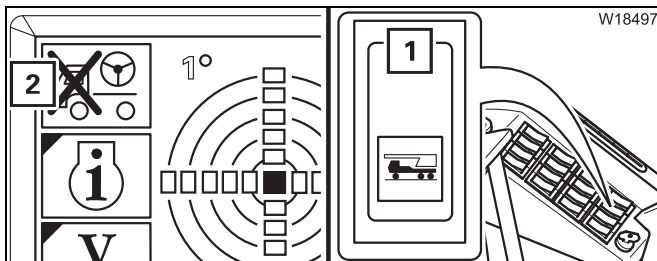

- Press the **(1)** button **up** once.
  - Lamp **(1)** goes out – engine for driving and carrier ignition off.
  - Symbol **(2)** **grey** – button **(2)** without function.

## 14.3

### Fuses

The fuses are located in different places on the superstructure:

- On the turntable,
- In the crane cab,
- At the RCL.

#### Information on replacing fuses

The positions of the fuses, their designations and which functions are protected by the respective fuses are shown in the following sections.

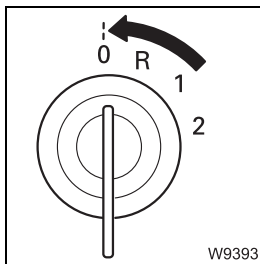

- Switch off the ignition whenever a fuse has to be replaced.



#### **Risk of damage if the ignition is switched on!**

Switch off the ignition whenever a fuse has to be replaced. This prevents the new fuse being blown immediately by the increased starting current after being installed.



#### **Risk of damage by overloading!**

Replace blown fuses only with new fuses of the same amperage. This prevents parts being overloaded and damaged or the fuse being immediately blown again.

Notify **Manitowoc Crane Care** if a fuse with the same amperage fails again once the ignition is switched on.





#### **Risk of fire!**

Never repair a blown fuse with other electrically conductive materials.

### 14.4.3

### Malfunctions on the main hoist/auxiliary hoist

Malfunction	Cause	Remedy
<b>Main hoist not working or malfunctioning</b>	Hoist off, lamp in button lights up dimly	▣▣▣▣ Switching on the main hoist, p. 11 - 55, ▣▣▣▣ Switching on the auxiliary hoist, p. 11 - 58
	Dead man's switch not actuated	Press dead man's switch
	Emergency stop switch engaged	▣▣▣▣ Resetting the emergency stop switch, p. 4 - 24
	Fuses F1/1, F3/1, F3/2, F3/5, F3/6 blown	Replace the blown fuse; ▣▣▣▣ p. 14 - 5
	Fuse blown on circuit board	Replace the blown fuse; ▣▣▣▣ p. 14 - 7
	Control unit faulty, error message is displayed	Acknowledge error message once; ▣▣▣▣ p. 14 - 36 – if error persists, notify <b>Manitowoc Crane Care</b>
	Fuse F3/7 blown	Replace the blown fuse; ▣▣▣▣ p. 14 - 9
<b>Only the lifting function works</b>	Lowering limit switch approached	Leave the shutdown range and lift the main hoist
<b>Only the lowering function works</b>	Lifting limit switch approached, lamp  lights up	Leave the shutdown range and lower the main hoist
	RCL shutdown, lamp  lights up	Leave the shutdown range; ▣▣▣▣ p. 11 - 37
	Fuse F3/3 blown	Replace the blown fuse; ▣▣▣▣ p. 14 - 9
<b>Lifting, lowering or high-speed mode function not working</b>	Function disabled by ECOS	If necessary, acknowledge error once and briefly turn off the ignition – if error persists, notify <b>Manitowoc Crane Care</b>
<b>No Lifting function</b>	Fuse RCL F6 faulty	Replace the blown fuse; ▣▣▣▣ p. 14 - 12
	Fuse F3/3 blown	Replace the blown fuse; ▣▣▣▣ p. 14 - 9
<b>Lifting or lowering is either not possible at all or only at a low speed</b>	Speed limited	Increase limit; ▣▣▣▣ p. 11 - 105
<b>Lifting or lowering function cannot be switched off</b>	ECOS malfunction	Emergency stop switch; ▣▣▣▣ p. 14 - 1
<b>No response to control lever movements</b>	ECOS malfunction concerning operating elements in the crane cab	Unrig using hand-held control; ▣▣▣▣ p. 14 - 59

### 14.4.13 Malfunctions of the outriggers

Malfunction	Cause	Remedy
<b>Outrigger cylinders and beams can neither be extended nor retracted and the inclination indicator does not work</b>	Driver's cab: Fuses A3F3, A3F13, A3F14 blown	Replace blown fuse; ➡ p. 7 - 20.
<b>When operating with the hand-held control</b>	Driver's cab: Fuse A2F3 blown	Replace blown fuse; ➡ p. 7 - 20.
<b>When operating from the crane cab</b>	Hand-held control connected to the superstructure or a bridging plug not inserted	Disconnect hand-held control or insert bridging plug; ➡ p. 12 - 21.
<b>When operating from the control units</b>	Display fields switched off.	Switch on display fields; ➡ p. 12 - 31
	Hand-held control connected to the superstructure or a bridging plug not inserted	Disconnect hand-held control or insert bridging plug; ➡ p. 12 - 21
<b>None of the specified causes apply</b>	Solenoid valves not working	<b>Manitowoc Crane Care</b> Report it

## 14.4.15 Malfunctions ECOS – superstructure

This section contains general malfunctions and malfunctions that generate an “error” display.

### ECOS programme version

Always note down the number of the program version before notifying **Manitowoc Crane Care** in the event of a malfunction.

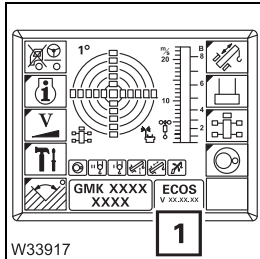

- If required, open the main menu .

The display (1) shows the number of the current programme version.

### General malfunctions

The following table contains information on troubleshooting and possible solutions.

Malfunction	Cause	Remedy
The ECOS display remains dark although the ignition is switched on	Fuse F1/1, F1/2 blown.	Replace the blown fuse; p. 14 - 6.
	Fuses F2/1, F2/2, F3/1, F3/6 blown.	
	One or more fuses on the circuit board in the distribution box are blown.	



Other malfunctions on the ECOS generate corresponding error messages.



## 14.5.2

### Telescoping emergency program

In the event of a malfunction in the telescoping mechanism, you can retract the main boom with the *Telescoping* emergency program.

**The emergency program is not intended for crane operation and is therefore restricted to a certain amount of time.**

- When a swing-away lattice is rigged;  *Starting the emergency program*, p. 14 - 47.
- When a swing-away lattice is folded to the side then you must perform the steps in the following section before telescoping.

When the *Telescoping* emergency program is switched on, the swing-away lattice is not automatically pivoted **before** and **after** telescoping.



#### **Risk of accidents due to the swing-away lattice falling!**

Before telescoping, always check the emergency programme to ensure that the swing-away lattice is in the telescoping position.

This way you will prevent telescoping parts from colliding with the swing-away lattice, brackets from coming off and the swing-away lattice from falling down.

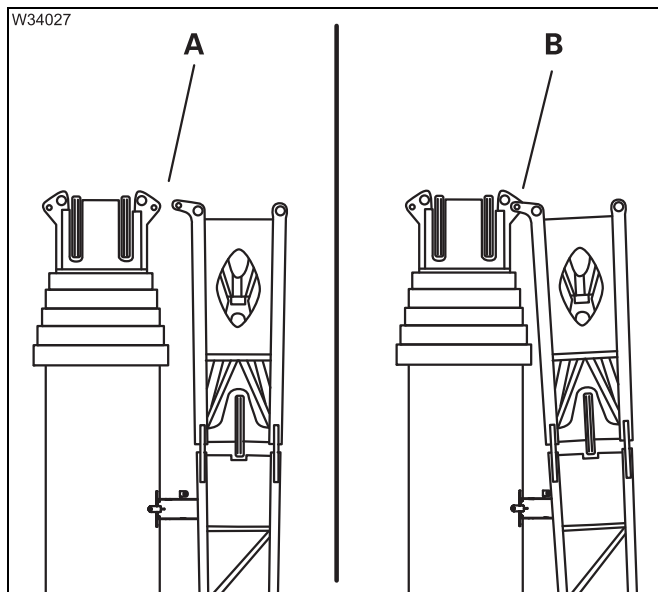

- Always check that all prerequisites are fulfilled before telescoping via an emergency program.

#### **(A) – Telescoping position**

When the swing-away lattice is in the telescoping position, you can telescope the main boom.

#### **(B) – Rigging position**

When the swing-away lattice is in the rigging position then you must first pivot it into the telescoping position (A) before telescoping.



**Tables for approaching the locking points**

The extent to which the telescoping cylinder has to be extended in order to reach a locking point depends on whether you want to lock:

- the telescoping cylinder or
- a telescopic section.

**Locking points for the telescoping cylinder**

The following table shows the extended length for locking the telescoping cylinder.

**Locking points for the telescopic sections**

<b>Table for locking the telescoping cylinder</b>		
<b>Telescopic section</b>	<b>Locking point at fixed length</b>	<b>Extended length of telescoping cylinder</b>
	<b>in%</b>	<b>in mm</b>
<b>Telescopic section I</b>	0	5
	50	5,350
	100	10,898
<b>Telescopic section II</b>	0	447
	50	5,752
	100	11,290
<b>Telescopic section III</b>	0	846
	50	6,124
	100	11,568
<b>Telescopic section IV</b>	0	1,155
	50	6,445
	100	11,911
<b>Telescopic section V</b>	0	1,440
	50	6,717
	100	12,168
<b>Telescopic section VI</b>	0	1,712
	50	6,941
	100	12,168



## 14.6

### Hydraulic emergency operation

With this additional equipment, the truck crane is equipped with a hydraulic emergency bleed valve in accordance with BGR 159 (4.2.8). This allows small loads to be transported in case of emergency, e.g. in the event of an engine failure.



#### **Risk of accidents due to improper use!**

Use hydraulic emergency operation only to transport small loads in emergencies. Have the malfunction rectified as soon as possible. Crane operation in hydraulic emergency operation is prohibited since it is not monitored by the RCL.

### 14.6.1

#### Operating principle

The hydraulic emergency operation BGR 159 enables:

- **Emergency operation** of the main hoist, derricking gear, and slewing gear
- **Emergency supply** of another truck crane that also has a hydraulic emergency operation BGR159.

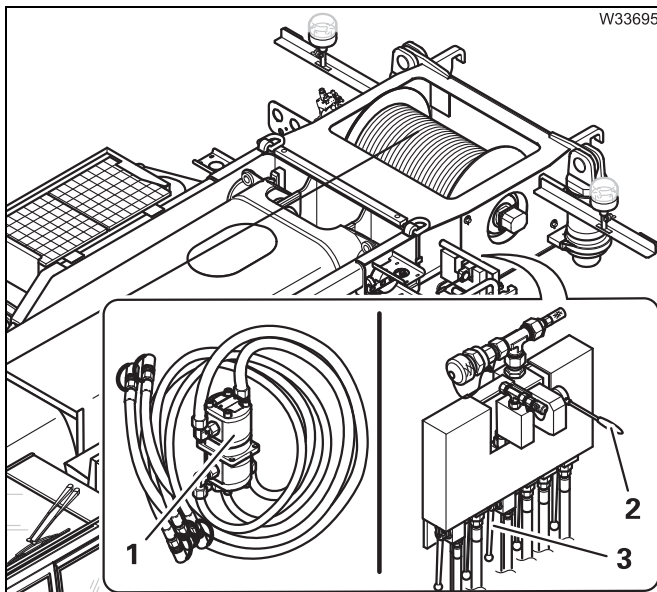

#### **Emergency operation**

The energy source for the crane hydraulic system is a transformer (1), which is driven by

- the carrier hydraulic system or
- the emergency hydraulic unit or
- the emergency supply of another truck crane

The hydraulic circuits are switched with the valves (3).

The control lever (2) regulates the direction of movement and the speed.



## 14.6.6

### After emergency operation

You must restore the truck crane to its original state after finishing emergency operation.

#### Switching off emergency operation

- Switch off the engine.

#### Switching over to crane operation

##### After every emergency operation

- Switch valves **1** to **5** to crane operation;  p. 14 - 69.

##### Also after lifting/lowering

- Switch off continuous operation at the valves Y1105 and Y1104;  p. 14 - 71.

##### Also after slewing

- Open the valve **6**;  p. 14 - 72.

#### Disconnecting the hoses

- Disconnect the hoses;  p. 14 - 67.
- Close all the connections and hoses with the caps.
- Remove the transformer.

<b>A</b>	Access ladders on the carrier .....	4 - 4
	Adjusting axle	
	pressure .....	6 - 15
	adjusting the mirrors	
	for driving .....	5 - 8
	on the superstructure .....	12 - 123
	Air intake inhibitor .....	4 - 25
	On the engine for crane operation .....	10 - 23
	Air-conditioning system	
	In the crane cab .....	11 - 133
	in the driver's cab .....	5 - 78
	Auxiliary hoist .....	11 - 57
	Installing/removing	
	Checking for correct functioning .....	6 - 103
	Checklist	
	Assembly .....	6 - 89
	Removal .....	6 - 91
	Creating the connection to the turntable .....	6 - 98
	electrical connection .....	6 - 97
	hydraulic connection .....	6 - 96
	Slinging points .....	6 - 93
	Transport .....	6 - 102
	Lifting and lowering .....	11 - 59
	Setting down for figging .....	6 - 95
	Short description of the operating elements .....	9 - 80
	Switching off .....	11 - 59
	switching on .....	11 - 58
	Axle loads	
	Required speed limit .....	6 - 6
	Weighing the truck crane .....	6 - 7
<b>B</b>	Battery master switch .....	4 - 10
	Superstructure .....	10 - 7
	Boom pre-tensioning	
	Switching off .....	12 - 17, 12 - 19
	switching on .....	6 - 13, 6 - 14
	Brakes	
	Additional brakes .....	3 - 54, 5 - 46
	Compressed-air supply after engine failure .....	7 - 6
	Operating elements in the driver's cab .....	3 - 54
	parking brake .....	3 - 55
	Checking for correct functioning .....	5 - 11
	towing a trailer	
	checking the braking force .....	5 - 92

Behind the cover .....	3 - 10
front .....	3 - 6
rear .....	3 - 11
Operating elements in the driver's cab	
Override torque reduction .....	5 - 53
Warning instrument panel .....	5 - 51
Operating Manual	
example of how to use cross-references .....	1 - 28
finding information .....	1 - 27
structure of the chapters and pages .....	1 - 25
symbols used .....	1 - 23
Outrigger pressure display .....	12 - 52
Outrigger pressure displays	
Short description of the operating elements .....	9 - 73
Outriggers .....	12 - 27
CHECKLIST - extending .....	12 - 27
CHECKLIST - retracting .....	12 - 29
Determining the required load-bearing area .....	12 - 9
Enlarging the load-bearing area .....	12 - 40
extending/retracting auxiliary supports .....	6 - 71
Extending/retracting outrigger beams .....	12 - 35
from the control units .....	12 - 36
from the crane cab .....	12 - 37
extending/retracting supporting cylinders .....	12 - 41
From the control units .....	12 - 42
from the crane cab .....	12 - 43
Levelling the truck crane on outriggers	
Automatic .....	12 - 49
Inclination indicators .....	12 - 46
Manual .....	12 - 48
Outrigger pads	
moving into driving position .....	12 - 39
moving into working position .....	12 - 39
Outrigger pressure display .....	12 - 52
permissible outrigger spans .....	12 - 30
Preparing the truck crane for rigging .....	12 - 31
Removing/installing outrigger beams .....	6 - 47
CHECKLIST	
Assembly .....	6 - 50
Removal .....	6 - 48
Disconnecting/establishing the connection to the supporting box .....	6 - 59
electrical connection .....	6 - 56
extending/retracting outrigger beams .....	6 - 60
hydraulic connection .....	6 - 55
Removing/attaching outrigger pads .....	6 - 53
Transport .....	6 - 63
Unscrewing/screwing in the spacers .....	6 - 57
Setting the outrigger spans .....	12 - 32
Short description of the operating elements .....	9 - 66

CLICK HERE TO **DOWNLOAD** THE COMPLETE MANUAL

- Thank you very much for reading the preview of the manual.
- You can download the complete manual from: [www.heydownloads.com](http://www.heydownloads.com) by clicking the link below



- Please note: If there is no response to CLICKING the link, please download this PDF first and then click on it.

CLICK HERE TO **DOWNLOAD** THE COMPLETE MANUAL