

Disassembly and Assembly

C-10 and C-12 Truck Engines

1YN1-Up (Engine)
2PN1-Up (Engine)

CLICK HERE TO **DOWNLOAD** THE COMPLETE MANUAL

- Thank you very much for reading the preview of the manual.
- You can download the complete manual from: www.heydownloads.com by clicking the link below



- Please note: If there is no response to CLICKING the link, please download this PDF first and then click on it.

CLICK HERE TO **DOWNLOAD** THE COMPLETE MANUAL

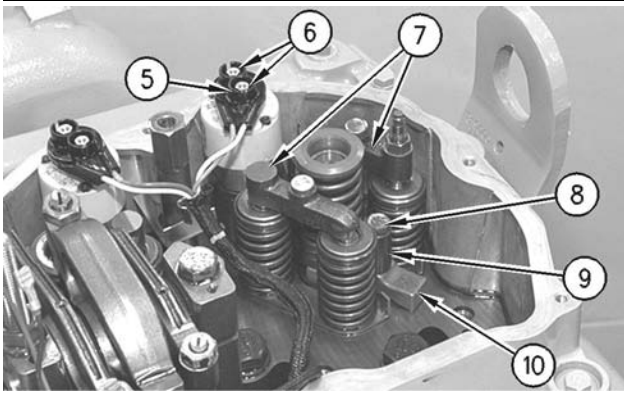

Illustration 18 g00511929

3. Lubricate the bore lightly with a 50/50 mix of clean engine oil and **8T-2998** Lubricant.

Note: The injector code will be used later if the injectors have been changed. Write down the injector code which is located on the solenoid.

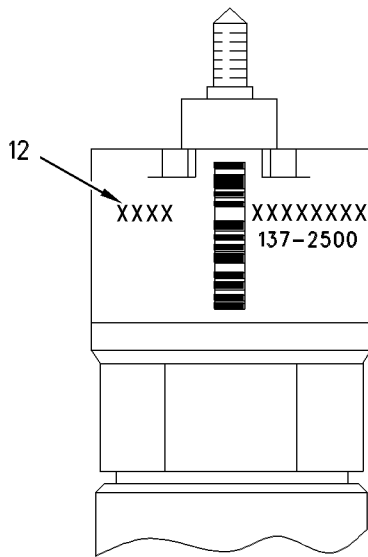

Illustration 19 g00529729

(12) Electronic injector code

NOTICE

When a fuel injector group is serviced, the new fuel injector group's electronic injector code must be programmed into the engine's personality module software by using the calibration menu on the Electronic Service Tool. If the new fuel injector group's electronic code is not entered, the previous fuel injector group's characteristics are assumed.

If it is not possible to immediately reprogram the electronic injector code of the injector into the personality module software, the engine will not be severely harmed. The new electronic injector code should be reprogrammed as quickly as possible in order to optimize engine performance.

4. Position the unit injector (3) in the cylinder head assembly. Place the hold down clamp (10) at the base of the unit injector. Push down on the return spring of the unit injector in order to seat the unit injector.
5. Install spacer assembly (9) and bolt (8) that holds the unit injector in place.
6. Pull the unit injector completely into the bore. Tighten the bolt to a torque of 30 N·m (22 lb ft).
7. Install cap assembly (5). Tighten nuts (6) to a torque of 2.5 ± 0.25 N·m (22 ± 2 lb in).
8. Install bridge assemblies (7) onto the valve stems.

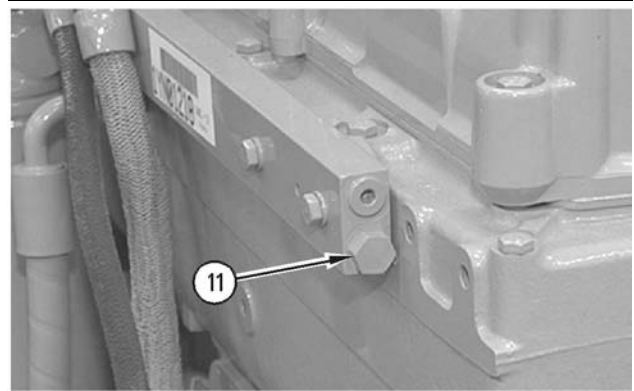

Illustration 20 g00511936

9. Install plug (11) in the fuel manifold.

End By:

- a. Install the rocker shaft and the pushrods. Refer to Disassembly and Assembly, "Rocker Shaft and Pushrod - Install".

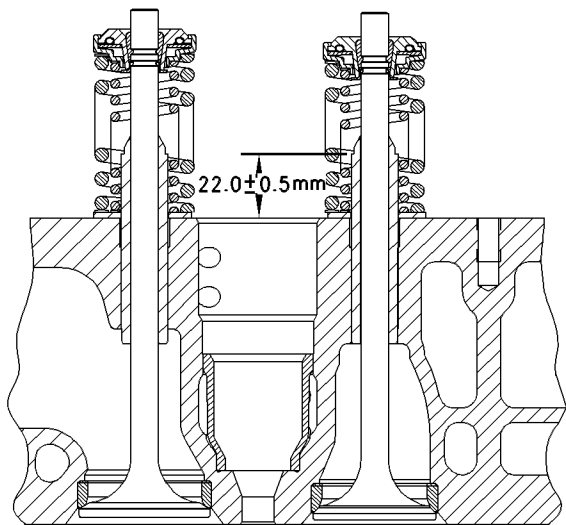

Illustration 44

g00513519

1. Position the valve guide and tap on the top of the valve guide. This is done in order to start the valve guide into the cylinder head assembly.
2. Use Tooling (A) to install the valve guides. Install the valve guides until the protrusion is 22.0 ± 0.5 mm (0.87 ± 0.02 inch) above the cylinder head assembly.

End By:

- a. Install the inlet valves and exhaust valves. Refer to Disassembly and Assembly, "Inlet and Exhaust Valves- Remove and Install".

Inlet and Exhaust Valve Seat Inserts - Remove and Install

SMCS Code: 1103-010

Removal Procedure

Table 14

Required Tools			
Tool	Part Number	Part Description	Qty
A	9U-6460	Valve Guide and Seat Tool Group	1

Start By:

- a. Remove the inlet and exhaust valves. Refer to Disassembly and Assembly, "Inlet and Exhaust Valves - Remove and Install".

NOTICE

Keep all parts clean from contaminants.

Contaminants may cause rapid wear and shortened component life.

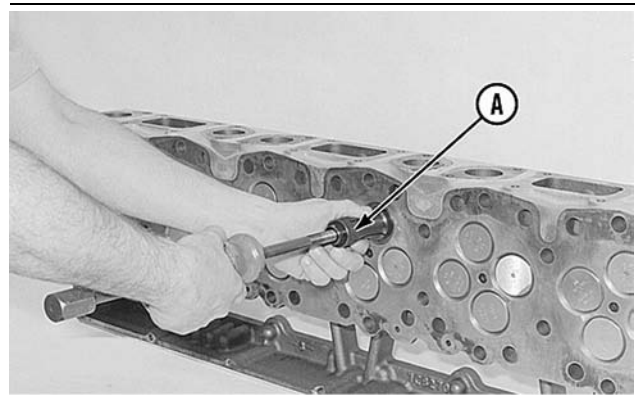

Illustration 45

g00513641

Typical example

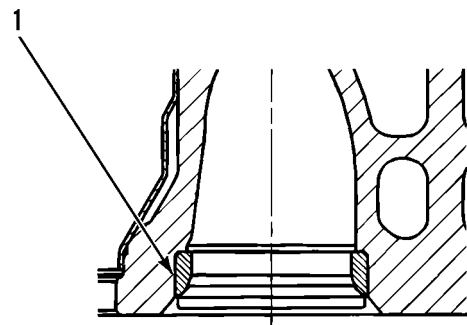

Illustration 46

g00513644

1. Use Tooling (A) to remove valve seat inserts (1).

Installation Procedure

Table 15

Required Tools			
Tool	Part Number	Part Description	Qty
A	9U-6460	Valve Guide and Seat Tool Group	1

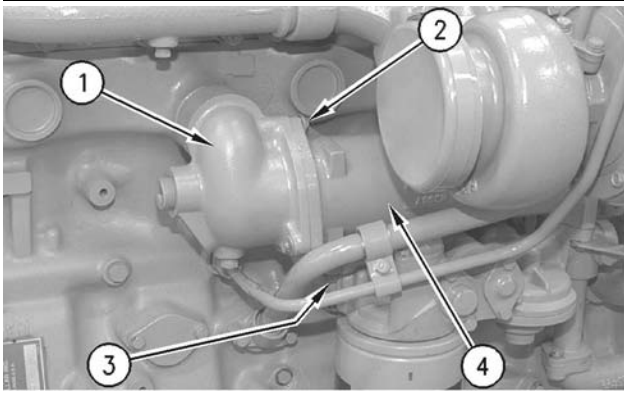

Illustration 80
Typical example g00513708

3. Install the two O-ring seals on the oil filter base. Position the oil cooler (4) on the oil filter base.
4. Install two bolts (6) with washers and two bolts (3) with washers.
5. Install three bolts (5) with washers. Tighten hose clamp (7).
6. Install the O-ring seals on elbow (1) of the engine oil cooler.
7. Lubricate the bore lightly with glycerin. Position the elbow of the engine oil cooler on engine oil cooler core (4).
8. Install three bolts (2) and the washers.
9. Fill the cooling system with coolant to the correct level. Refer to Operation and Maintenance Manual for the correct filling procedure.

i01000454

Engine Oil Pump - Remove

SMCS Code: 1304-011

Removal Procedure

NOTICE

Keep all parts clean from contaminants.

Contaminants may cause rapid wear and shortened component life.

NOTICE

Care must be taken to ensure that fluids are contained during performance of inspection, maintenance, testing, adjusting and repair of the machine. Be prepared to collect the fluid with suitable containers before opening any compartment or disassembling any component containing fluids.

Refer to Special Publication, NENG2500, "Caterpillar Tools and Shop Products Guide", for tools and supplies suitable to collect and contain fluids in Caterpillar machines.

Dispose of all fluids according to local regulations and mandates.

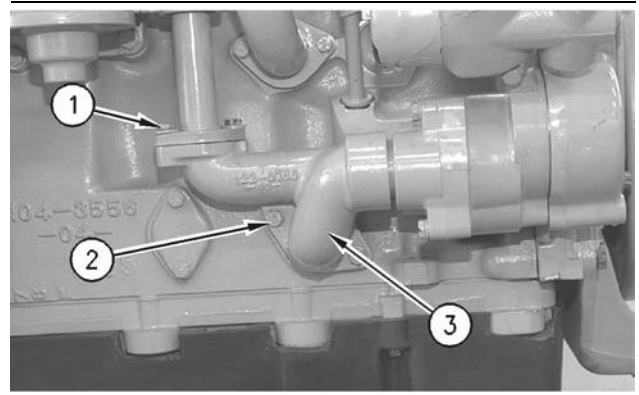

Illustration 81 g00512289

1. Remove bolts (1) and the washers that hold the tube to the elbow of the oil pump.
2. Remove bolts (2) and the washers that hold the elbow of oil pump (3) to the cylinder block.

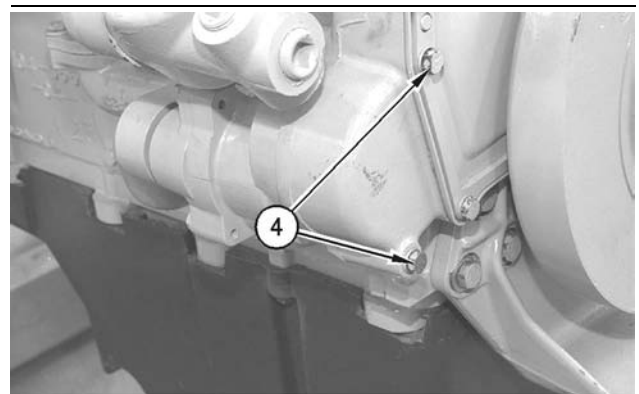

Illustration 82 g00512297

3. Remove bolts (4) and the washers that hold the engine oil pump to the front housing. Remove the engine oil pump and the elbow as a unit.
4. Remove the two O-ring seals. One O-ring seal is on the connection of the tube to the elbow. The second O-ring seal is on the engine oil pump.

i01771159

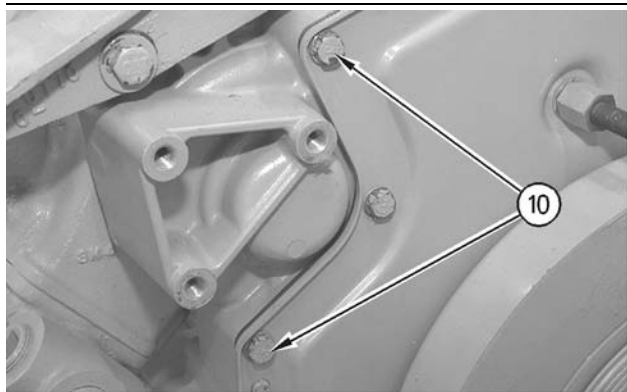

Illustration 116

g00513753

2. Install the O-ring seal on water pump (7). Lubricate the bore lightly with clean engine oil.
3. Lubricate the O-ring seals with coolant and install the O-ring seals on tube assembly (5). Install tube assembly (5) on water pump (7).
4. Position water pump (7) and tube assembly (5) in the front housing. Install two bolts (10) and the washers. Tighten the bolts to a torque of 28 ± 7 N·m (21 ± 5 lb ft).
5. Position the flange gasket between tube assembly (5) and the water temperature regulator housing. Install two bolts (4) and the washers. Tighten the bolts to a torque of 28 ± 7 N·m (21 ± 5 lb ft).
6. Install hose (1) and tighten hose clamp (2).
7. Put new plastic tie (3) on tube assembly (5) in order to hold the wiring.
8. Install two bolts (9) and washers into the alternator bracket.
9. Install dipstick tube (6) with bolt (8) and the washer.
10. Fill the cooling system with coolant to the correct level. Refer to the Operation and Maintenance Manual for the correct filling procedure.

End By:

- a. Install the engine oil cooler. Refer to Disassembly and Assembly, "Engine Oil Cooler Install".
- b. Install the belt tensioner. Refer to Disassembly and Assembly, "Belt Tensioner - Remove and Install".
- c. Install the alternator. Refer to Disassembly and Assembly, "Alternator - Remove and Install".

Water Temperature Regulator - Remove and Install

SMCS Code: 1355-010

Removal Procedure

⚠ WARNING

Personal injury can result from hot coolant, steam and alkali.

At operating temperature, engine coolant is hot and under pressure. The radiator and all lines to heaters or the engine contain hot coolant or steam. Any contact can cause severe burns.

Remove cooling system pressure cap slowly to relieve pressure only when engine is stopped and cooling system pressure cap is cool enough to touch with your bare hand.

Do not attempt to tighten hose connections when the coolant is hot, the hose can come off causing burns.

Cooling System Coolant Additive contains alkali. Avoid contact with skin and eyes.

NOTICE

Keep all parts clean from contaminants.

Contaminants may cause rapid wear and shortened component life.

NOTICE

Care must be taken to ensure that fluids are contained during performance of inspection, maintenance, testing, adjusting and repair of the product. Be prepared to collect the fluid with suitable containers before opening any compartment or disassembling any component containing fluids.

Refer to Special Publication, NENG2500, "Caterpillar Tools and Shop Products Guide" for tools and supplies suitable to collect and contain fluids on Caterpillar products.

Dispose of all fluids according to local regulations and mandates.

1. Drain the coolant from the system into a suitable container for storage or disposal.

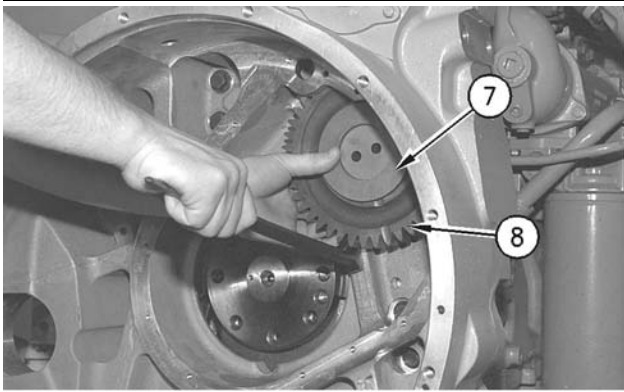

Illustration 146 g00520763

7. Use a pry bar in order to remove shaft (7) and gear assembly (8).

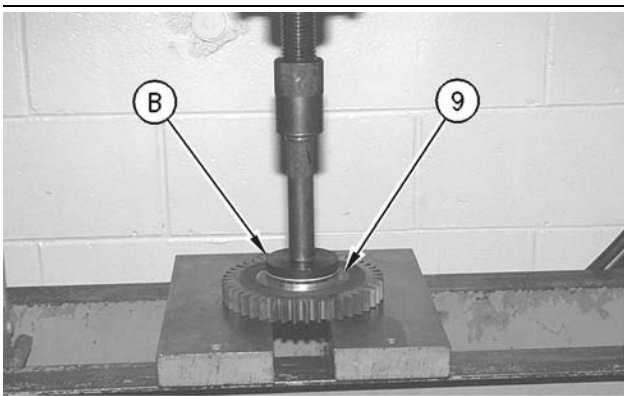

Illustration 147 g00520764

8. Inspect the condition of the bearing in gear assembly (8). If necessary, remove bearing (9) from the gear with Tooling (B).

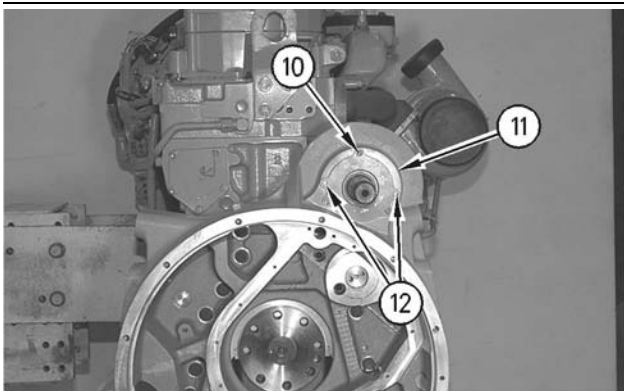

Illustration 148 g00520766

9. Remove bolts (10) that fasten carrier assembly (11) to the flywheel housing. Install two bolts (10) opposite each other at location (12). Use these bolts as forcing screws in order to remove carrier assembly (11).

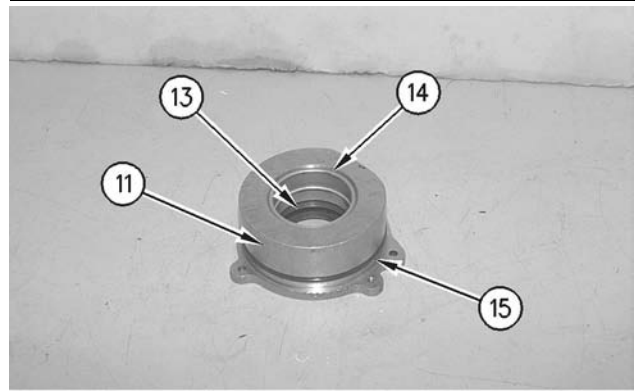

Illustration 149 g00765120

10. Remove O-ring seal (15) and lip type seal (13) from carrier assembly (11).

11. Inspect the condition of bearing (14). If necessary, use Tooling (B) to remove bearing (14) from carrier assembly (11).

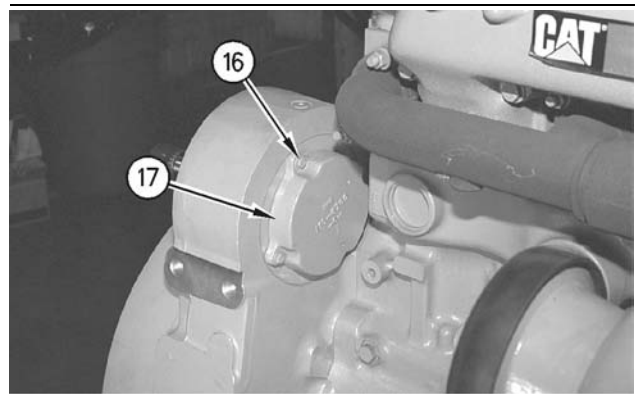

Illustration 150 g00520769

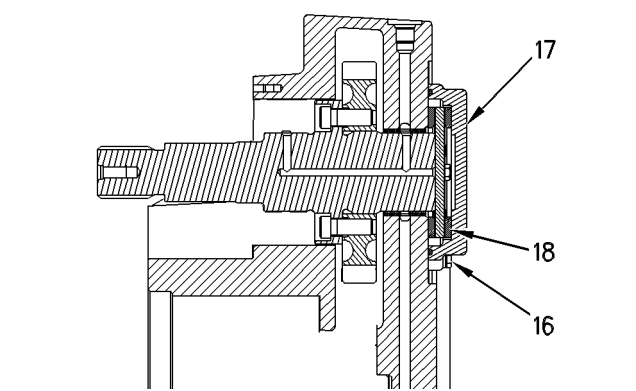

Illustration 151 g00520770

12. Remove bolts (16), cover assembly (17), and thrust washer (18). Replace the O-ring seal.

13. Inspect the condition of thrust washer (18). Replace thrust washer (18), if necessary.

Note: The minimum allowable thickness for thrust washer (18) is 4.665 mm (0.1837 inch).

CLICK HERE TO **DOWNLOAD** THE COMPLETE MANUAL

- Thank you very much for reading the preview of the manual.
- You can download the complete manual from: www.heydownloads.com by clicking the link below



- Please note: If there is no response to CLICKING the link, please download this PDF first and then click on it.

CLICK HERE TO **DOWNLOAD** THE COMPLETE MANUAL

i01464328

i01667069

Housing (Front) - Remove

SMCS Code: 1151-011

Removal Procedure

Start By:

- a. Remove the front gear group. Refer to Disassembly and Assembly, "Gear Group (Front) - Remove".

NOTICE

Care must be taken to ensure that fluids are contained during performance of inspection, maintenance, testing, adjusting and repair of the product. Be prepared to collect the fluid with suitable containers before opening any compartment or disassembling any component containing fluids.

Refer to Special Publication, NENG2500, "Caterpillar Tools and Shop Products Guide" for tools and supplies suitable to collect and contain fluids on Caterpillar products.

Dispose of all fluids according to local regulations and mandates.

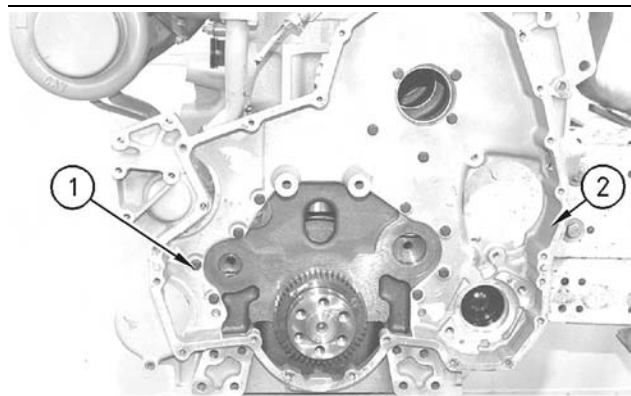

Illustration 182

g00514280

1. Remove thirteen bolts (1) and the washers.
2. Remove front housing (2) and the gasket.

Housing (Front) - Install

SMCS Code: 1151-012

Installation Procedure

The front of the engine block has been modified. This modification requires the use of different bolts that attach the front housing to the engine block. The correct bolts need to be used to attach the front housing. Use Table 30 to identify your type of engine.

Table 30

	Engine Model	Serial Number (Type 1)	Serial Number (Type 2)
Industrial	3176C	2AW1-1328	2AW1329-Up
	3196	1DW1-627	1DW628-Up
	C-10	BCX1-268	BCX269-Up
	C-12	BDL1-236	BDL237-Up
Machine	3176C	3PD1-450	3PD451-Up
	3176C	7ZR1-6108	7ZR6109-Up
	3196	5ED1-428	5ED429-Up
	3196	6AR276-2872	6AR2873-Up
	C12	-	JAC1-Up
Marine	3176C	6BW333-500	6BW501-Up
	3196	2XR1-4150	2XR4151-42478
	C12	-	9HP1-Up
Truck	C-10	2PN1-Up	-
	C-10	8YS1-Up	-
	C-10	3CS1-21950	3CS21951-Up
	C-12	1YN1-Up	-
	C-12	9NS1-Up	-
	C-12	2KS1-69602	2KS69603-Up
	C-12	CPD1-304	CPD305-Up
	C-12	CPN1-323	CPN324-Up
	C-12	9SM1-862	9SM863-Up

Table 30 is your guide for selecting your correct type of engine. If your engine is a Type 1 proceed to "Type 1". If your engine is a Type 2 proceed to "Type 2". If you have a remanufactured engine then proceed to "Remanufactured Engines". The following illustrations will provide added information on the installation of the front housing.

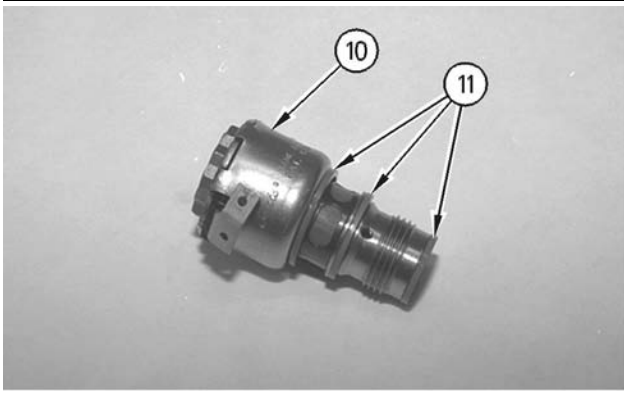

Illustration 212
Typical example

8. Remove three O-ring seals (11) from solenoid valve (10). Discard the O-ring seals.

Note: The lower O-ring may stay in the bore in the compression brake housing. If this is the case, use a seal pick to remove the O-ring from the compression brake housing.

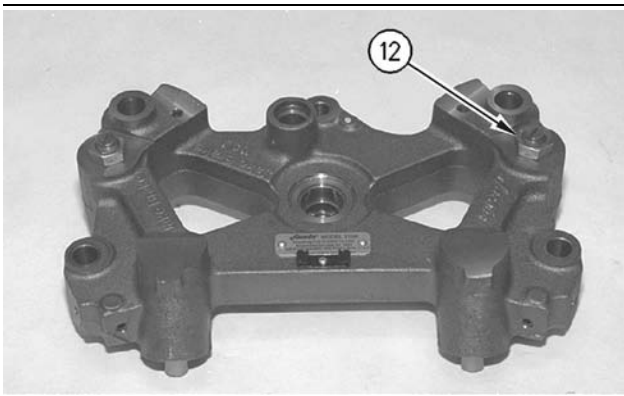

Illustration 213

NOTICE

Do not disassemble or tamper with slave piston adjusting screw. Engine damage could result.

9. Remove slave piston adjustment screw locknut (12).

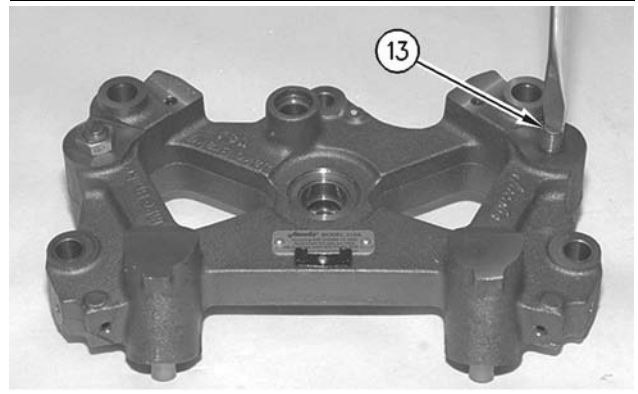

Illustration 214

10. Loosen slave piston adjustment screw (13) until the slave piston is fully retracted.

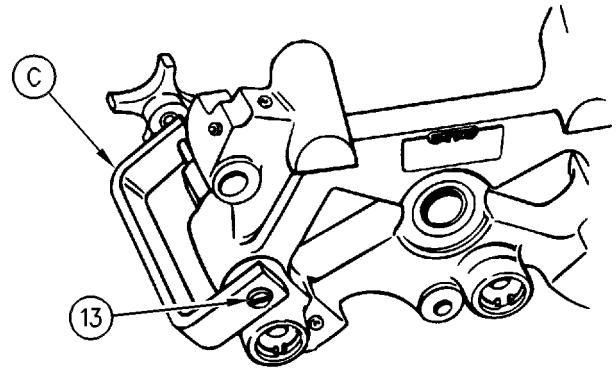

Illustration 215

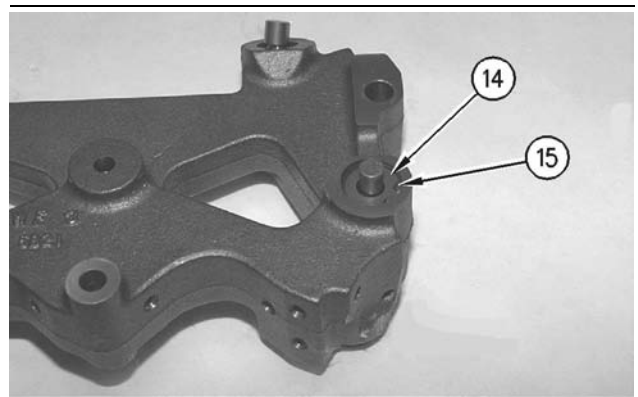

Illustration 216

i01792874

Cylinder Head - Install

SMCS Code: 1100-012

Installation Procedure

Table 37

Required Tools			
Tool	Part Number	Part Description	Qty
A	185-3630	Strap Wrench Assembly	1
B	1U-5686 ⁽¹⁾	21/32 inch Drill Bit	1
C	4C-9732 ⁽¹⁾	M16x2.0-D7 Plug Tap	1
D	9U-5604	M16x2.0 32mm Heli-Coil Insert ⁽²⁾	1
E	8T-2799 ⁽¹⁾	Heli-Coil Installation Tool	1
F	8T-3096	Plug Tap	1
G	6V-4876	Lubricant	1

⁽¹⁾ Part of 4C-8367 Thread Repair Kit

⁽²⁾ This is a special length.

NOTICE

Keep all parts clean from contaminants.

Contaminants may cause rapid wear and shortened component life.

Note: For more information, refer to Video Tape, LEVN5101, "C-10 and C-12 Head Gasket Repair Procedure".

1. Thoroughly clean the mating surfaces of the cylinder head and the cylinder block.
2. Clean all 26 head bolt holes on the cylinder block with Tooling (F).
3. After cleaning the threads, remove any debris from the head bolt holes on the cylinder block with a vacuum line.
4. Visually inspect the head bolt holes on the cylinder block for thread damage.
5. If a damaged head bolt thread is observed, repair the damaged head bolt thread with a Heli-Coil thread repair kit.
6. Inspect the cylinder head and the cylinder block for flatness. Refer to Guideline for Reusable Parts and Salvage Operations, SEBF8162, "Procedure to Measure and Salvage Cylinder Head Assemblies and Related Components".

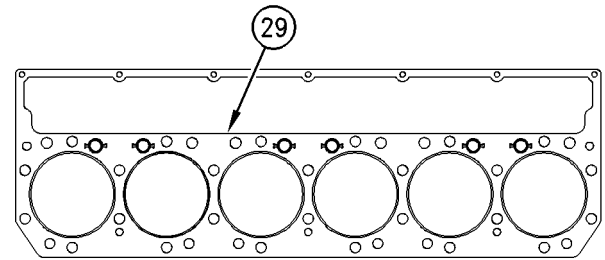

Illustration 248
Cylinder Head Gasket
(29) Straight Edge

g00810396

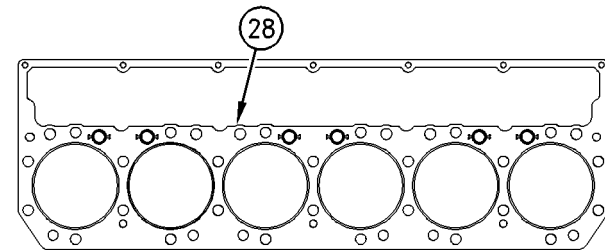

Illustration 249
Cylinder Head Gasket
(28) Scalloped Edge

g00810399

7. Determine the correct cylinder head gasket to use. Refer to Illustration 248 and Illustration 249.

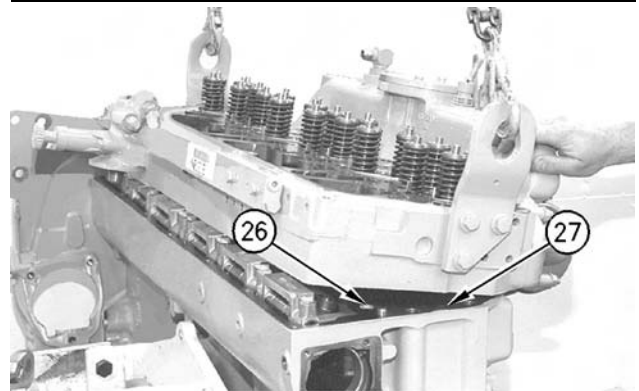

Illustration 250

g00525775

8. Install the correct cylinder head gasket (26) and new O-ring seals (27) on the cylinder block. Inspect the condition of the remaining gaskets. Replace the gaskets, if necessary.

NOTICE

Care must be taken to ensure that fluids are contained during performance of inspection, maintenance, testing, adjusting and repair of the product. Be prepared to collect the fluid with suitable containers before opening any compartment or disassembling any component containing fluids.

Refer to Special Publication, NENG2500, "Caterpillar Tools and Shop Products Guide" for tools and supplies suitable to collect and contain fluids on Caterpillar products.

Dispose of all fluids according to local regulations and mandates.

1. Drain the engine oil into a suitable container for storage or disposal.

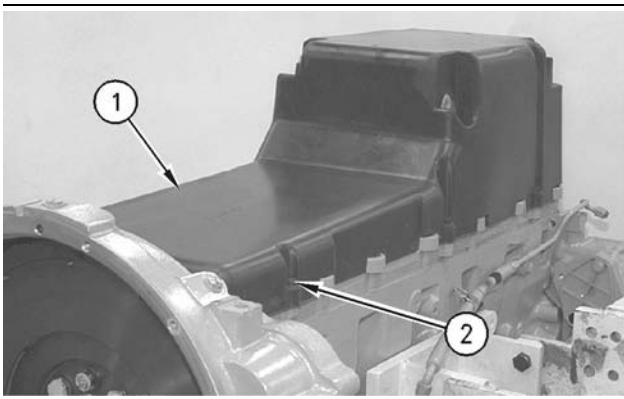

Illustration 276
Typical example
g00516290

2. Remove six bolts (2) and the washers. Remove sound suppression cover (1), if equipped.

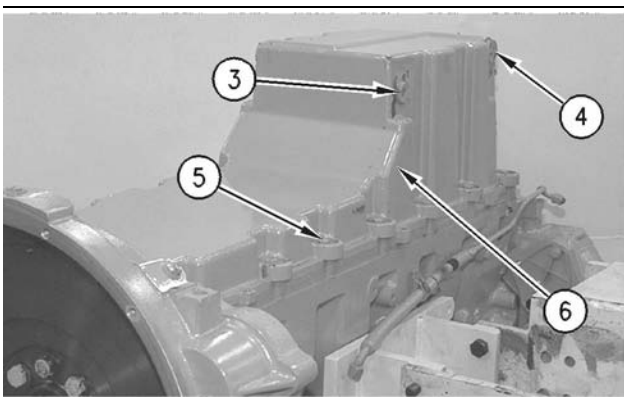

Illustration 277
Typical example
g00516292

3. Remove the following items from the cylinder block: fourteen bolts (5), the washers, the isolators, and the isolator sleeves.
4. Remove engine oil pan (6) and the gasket.

5. Remove pipe plug (3) and drain plug (4) with the O-ring seal, if necessary.

Installation Procedure

NOTICE

Keep all parts clean from contaminants.

Contaminants may cause rapid wear and shortened component life.

1. Inspect the condition of the gasket. Replace the gasket, if necessary.
2. Clean the mating surface of the engine oil pan and the cylinder block.

Note: Apply **8T-9022** Silicone Gasket to the right and the left edges of the cylinder block prior to installation.

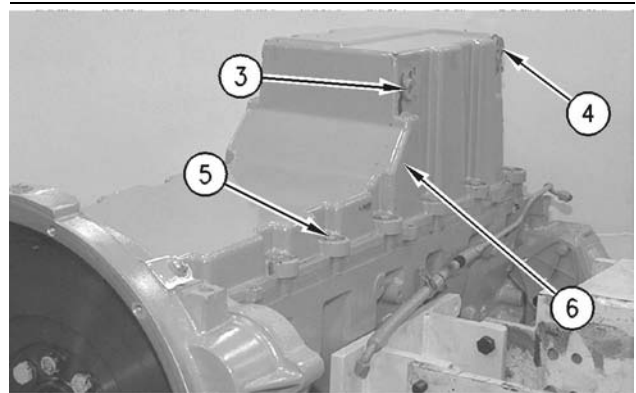

Illustration 278
Typical example
g00516292

3. Place the gasket and engine oil pan (6) on the cylinder block.
4. Install the following items: isolator sleeves, isolators, bolts (5), and the washers.

Note: Perform the following procedure in order to eliminate the possibility of an oil leak from the bolt for the engine oil pan:

Note: The path of the oil leak is through the threads of the bolt for the engine oil pan. The third bolt from the front of the engine block on the right side of the engine is the suspect bolt.

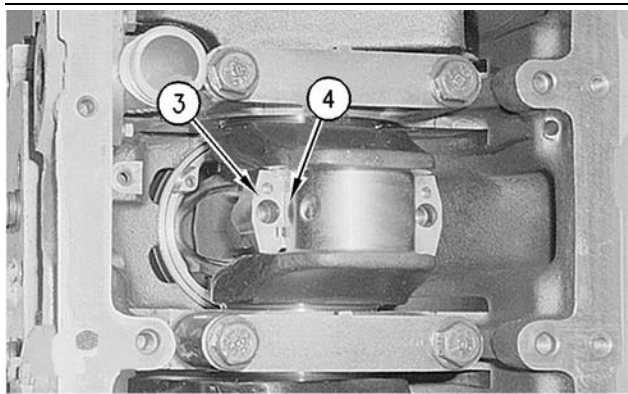

Illustration 302

g00522735

1. Install the upper half of connecting rod bearing (4) into connecting rod (3). Ensure that the bearing tab engages with the slot in the connecting rod.
2. Apply clean engine oil on the surface of the upper half of connecting rod bearing (4).
3. Position connecting rod (3) and connecting rod bearing (4) on the crankshaft.

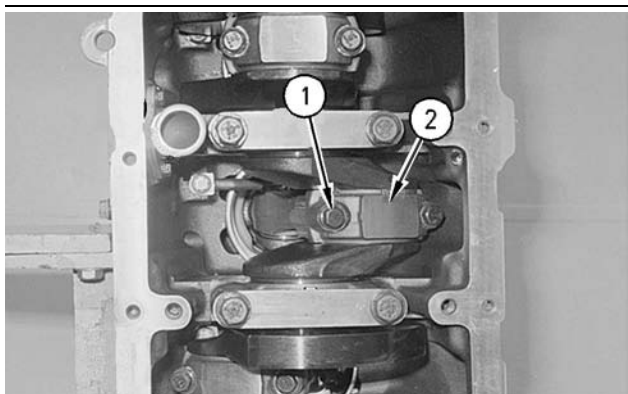

Illustration 303

g00522734

4. Install the lower half of the connecting rod bearing in corresponding connecting rod cap (2). Ensure that the bearing tab engages with the groove in connecting rod cap (2).
5. Apply clean engine oil on the surface of the lower half of the connecting rod bearing.
6. Install connecting rod cap (2) on the corresponding connecting rod. Ensure that the numbers are on the same side.
7. Install connecting rod cap bolts (1). Tighten the bolts to a torque of 130 ± 7 N·m (95 ± 5 lb ft).
8. Place an index mark on each bolt head. Tighten each bolt for an additional 60 ± 5 degrees ($1/6$ turn).

9. Repeat Steps 1 through 8 in order to install the remaining connecting rod bearings.

End By:

- a. Install the engine oil pan. Refer to Disassembly and Assembly, "Engine Oil Pan - Remove and Install".

i01772186

Crankshaft Main Bearings - Remove

SMCS Code: 1203-011

Removal Procedure

Table 47

Required Tools			
Tool	Part Number	Part Description	Qty
A	2P-5518	Bearing Tool	1

Start By:

- a. Remove the oil pan. Refer to Disassembly and Assembly, "Engine Oil Pan - Remove and Install".

NOTICE

Keep all parts clean from contaminants.

Contaminants may cause rapid wear and shortened component life.

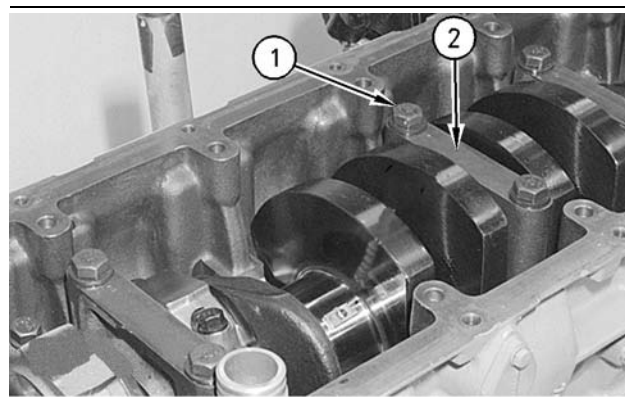

Illustration 304

g00824745

1. Remove bolts (1) that hold crankshaft main bearing cap (2). Remove crankshaft main bearing cap (2).
2. Remove the lower half of the crankshaft main bearing from crankshaft main bearing cap (2).

i01582984

Belt Tensioner - Remove and Install

SMCS Code: 1358-010

Removal Procedure



Illustration 330

g00519255

1. Use a breaker bar to release the tension on belt tightener (1). Remove the drive belt.

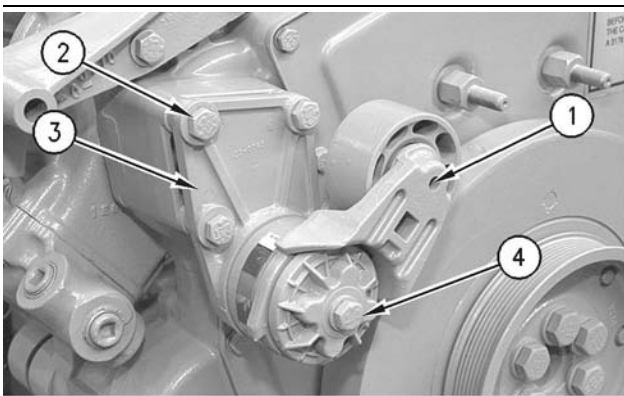

Illustration 331

g00519256

2. Remove bolt (4) and the washer.
3. Remove belt tightener (1).
4. Remove three bolts (2) and the washers.
5. Remove support (3).

Installation Procedure

1. Inspect the condition of the belt tightener and the drive belt. Replace the tightener and the belt, if necessary.

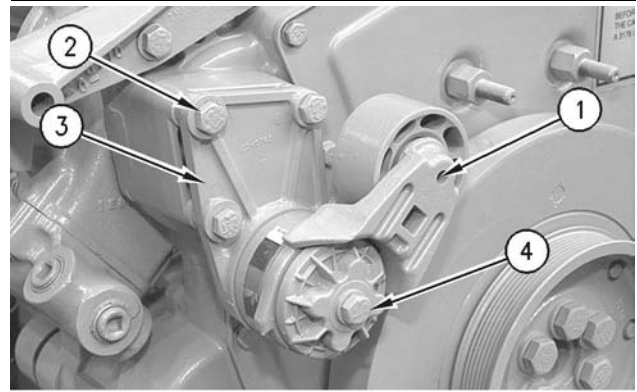

Illustration 332

g00519256

2. Install support (3) on the front housing with three bolts (2) and the washers. Tighten the bolts to a torque of 55 ± 10 N·m (41 ± 7 lb ft).
3. Install belt tightener (1) with bolt (4) and the washer. Tighten the bolt to a torque of 55 ± 10 N·m (41 ± 7 lb ft).
4. Use a breaker bar to rotate the belt tensioner. Install the drive belt while the belt tensioner is rotated. Allow the tensioner to rotate in order to apply tension to the belt. Remove the breaker bar from the belt tensioner.

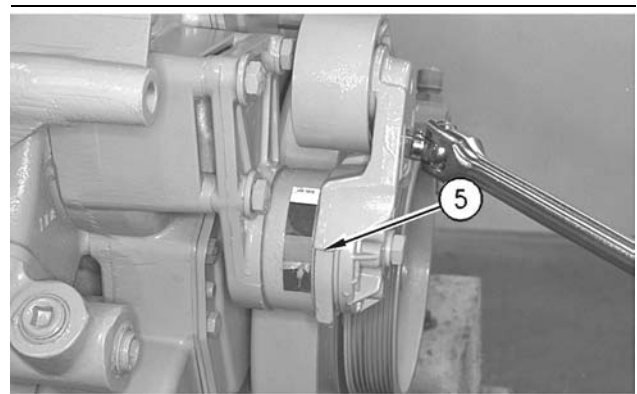

Illustration 333

g00519259

5. If the alternator is equipped with an adjustable support strap, adjust the position of the alternator until the indicator edge (5) is aligned with the green area of the indicator decal.

CLICK HERE TO **DOWNLOAD** THE COMPLETE MANUAL

- Thank you very much for reading the preview of the manual.
- You can download the complete manual from: www.heydownloads.com by clicking the link below



- Please note: If there is no response to CLICKING the link, please download this PDF first and then click on it.

CLICK HERE TO **DOWNLOAD** THE COMPLETE MANUAL