

CM870 COMMON APPROACH TO CONTROL SYSTEM DIAGNOSTICS

ENFORCER '02

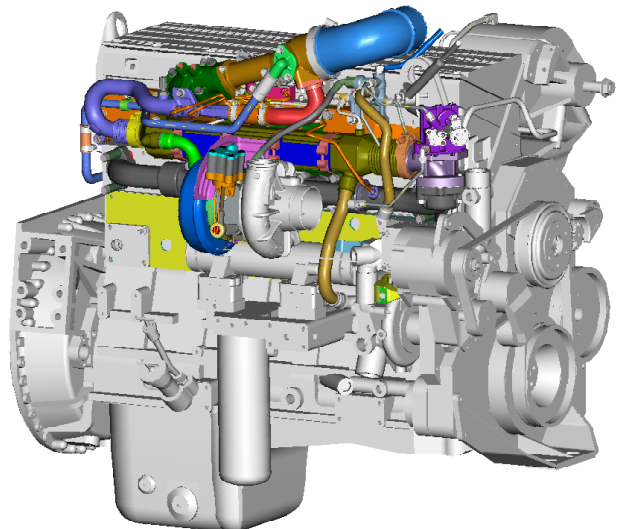
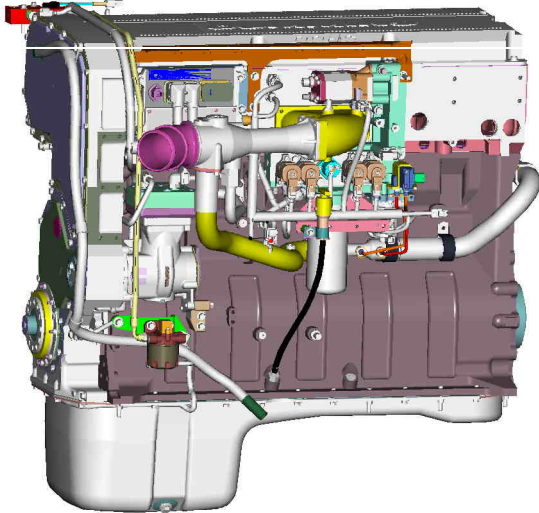

ISM '02

Brian J. Ouellette
HDD Controls Systems Integration

Phase 5.4 Software

CLICK HERE TO **DOWNLOAD** THE COMPLETE MANUAL

- Thank you very much for reading the preview of the manual.
- You can download the complete manual from: www.heydownloads.com by clicking the link below



- Please note: If there is no response to CLICKING the link, please download this PDF first and then click on it.

CLICK HERE TO **DOWNLOAD** THE COMPLETE MANUAL

CM870 COMMON APPROACH TO CONTROL SYSTEM DIAGNOSTICS

TROUBLESHOOTING AND DIAGNOSTICS PARAMETER GUIDE

THE FOLLOWING INDEX IDENTIFIES AVAILABLE CONTROL SYSTEM PARAMETERS

Engine Platforms: ENFORCER 02 / ISM 02
 ECM: PV CM870 Application Software: Phase 5.4

2002 CM870 Controls System

Performance Diagnostics:	Application Features:	Engineering Features:
ETIF Performance Evaluation:	106. NDOT Governor	136. User Overrides
75. EGR Valve and VGT Performance	107. All Speed Governor (ASG)	137. Torque To Fuel Conversion
76. Engine Brake Performance	108. High Idle Governor (HSG)	138. Keyon Pressure Check Diagnostics
77. Clutch Engagement Performance	109. Low Idle Governor (LSG)	139. General Engine Protection (EPF)
78. Engine Lug-Up / Lug-Down	110. Throttle Governor (Min/Max)	Compressor Outlet Temperature
79. Torque Response	111. Power Take-Off Governor (PTO)	Coolant Level
80. Coupled-Controller Performance During Gear Shifts	112. Road Speed Governor (RSG)	Coolant Temperature
81. Coolant and IMT Advance Controls	113. Cruise Control Governor (CC)	Coolant Temp2
82. PTO Response	114. SOI Timing Control	EGR Orifice Return Temperature
83. Snap Throttle Response (HSG/LSG Stationary)	115. SOI Timing Control – SOI Advance	EGR Orifice Return Temp2
84. Engine Start-up	116. Engine Start-up / Cranking	Exhaust Temperature
85. Low Idle Stability, Stationary	117. Engine Brake Manager	Intake Manifold Temperature
86. PTO Pump-Off	118. Engine Fan Control	Oil Pressure
87. Throttle Characterization	119. Alpha Determination	Oil Temperature
88. Snap Throttle Response (HSG Bobtail)	120. Noise Control – Speed Derates	140. In-Range Diagnostics
89. Throttle Control / Stability, Bobtail	121. Smart Torque (ST Ratings)	Charge Pressure IR Diagnostics
90. Idle In Gear, Bobtail	122. Load Based Speed Control (LBSC)	Turbo Speed IR Diagnostics
91. Gear Ratio Validation	Shift Manager (SM)	EGR Delta P In-Range Rationality Diagnostics
92. Cruise Control Base Functionality	Machine Mass Estimator (MME)	141. ECM Parameters
93. Road Speed Governor Base Functionality	123. CORS	
94. Cruise Control with Autoresume	124. Automated Transmissions	HPI-TP Fuel System:
95. Cruise Control with Engine Braking	125. Powertrain Controls	142. Fuel Systems Interface (FSI)
96. Cruise Control Overshoot	126. Powertrain Protection	143. Engine Speed Processing (EPS)
97. Road Speed Governor Overshoot	127. Limp Home Mode	144. Fuel Pressure Compensation (PCC)
98. Reverse ESP / Take-Off ESP	128. Out Of Gear Protection	145. Fuel Temperature Compensation (TCC)
99. High Idle Stability, Loaded Trailer	129. Gear Down Protection	146. Boost Pressure Compensation (BPC)
100. Throttle Control / Stability, Loaded Trailer	130. Starter Lockout	147. Solid Fuel Height Determination (SFH)
101. Idle In Gear, Loaded Trailer	131. Remote Throttle Control	148. Estimated Valve Delay (EVD)
102. Sensor Characterization	132. Remote PTO Control	149. Flow-To-Time Conversion (FTT)
103. Surge Characterization	133. Idle Shutdown	150. Cylinder Cut-Out Diagnostics (CTS)
Air Handling Controller Induced Surge	134. Turboconveyor	151. Cylinder Balancing Diagnostics (CBD)
Quasi-Steady State Compressor Surge	135. Ether Start Injection	152. Fuel Pressure Diagnostics (FPD)
Transient Compressor Surge		153. Fuel Shut Off (FSO) Controls
Engine Surge		154. Fuel System Fault Derate Handler (FDH)
104. OFC and Texh Fuel Limits		155. CBD / UFD Based Unintended Fueling Diag. (CUFD)
105. Dyno Performance Monitor		

Emission Features:

34. Torque Manager (TQM)

[TQM] Torque Manager:

Filtered_Engine_Speed	RPM	Engine_Protection_Derate_Torque	FT*LB
Ndot_Net_Torque_Cmd	FT*LB	TQM_Final_Torque_Cmd	FT*LB
Ndot_Net_Torque_Cmd_State	---	TQM_Net_Engine_Torque_State	---
Throttle_100_Torque	FT*LB	TQM_Net_Machine_Torque_Cmd	FT*LB
Fan_Torque	FT*LB	TQM_Net_Machine_Torque_State	---
AC_Torque	FT*LB		
Altitude_Derate_Torque	FT*LB	TQM_Engine_Torque_Limit	FT*LB
Out_Of_Gear_Torque	FT*LB	TQM_Engine_Torque_Limit_State	---
PTO_Derate_Torque	FT*LB	TQM_Machine_Torque_Limit	FT*LB
PTP_Torque_Output	FT*LB	TQM_Machine_Torque_Limit_State	---
WP_Startup_Torque_Limit	FT*LB	TQM_Net_Engine_Torque_Rqst	FT*LB

[TQM] Max Machine Torque:

Filtered_Engine_Speed	RPM	Torque_Derate_Override_Enable	---
Ndot_Net_Torque_Cmd	FT*LB	C_TQM_No_Derate_Torque	FT*LB
Ndot_Net_Torque_Cmd_State	---		
Throttle_100_Torque	FT*LB	TQM_Machine_Torque_Limit	FT*LB
Out_Of_Gear_Torque	FT*LB	TQM_Machine_Torque_Limit_State	---
PTO_Derate_Torque	FT*LB		
PTP_Torque_Output	FT*LB		

[TQM] Machine Torque Limiting:

Filtered_Engine_Speed	RPM	TQM_Machine_Torque_Limit	FT*LB
Ndot_Net_Torque_Cmd	FT*LB	TQM_Machine_Torque_Limit_State	---
Ndot_Net_Torque_Cmd_State	---		
MS_Control_Flag	---	TQM_Net_Machine_Torque_Cmd	FT*LB
MS_Override_Enable	HEX	TQM_Net_Machine_Torque_State	---
MS_Final_Override_Torque	FT*LB		
Torque_Derate_Override_Enable	---		

[TQM] Max Machine Torque:

Filtered_Engine_Speed	RPM	Torque_Derate_Override_Enable	---
Ndot_Net_Torque_Rqst	FT*LB	C_TQM_No_Derate_Torque	FT*LB
Ndot_Net_Machine_Torque_State	---		
Altitude_Derate_Torque	FT*LB	TQM_Engine_Torque_Limit	FT*LB
Engine_Protection_Derate_Torque	FT*LB	TQM_Engine_Torque_Limit_State	---
WP_Startup_Torque_Limit	FT*LB		

[TQM] Engine Torque Limiting:

Filtered_Engine_Speed	RPM	TQM_Final_Torque_Cmd	FT*LB
Ndot_Net_Torque_Rqst	FT*LB	TQM_Net_Engine_Torque_State	---
Ndot_Net_Machine_Torque_State	---		
TQM_Engine_Torque_Limit	FT*LB		
TQM_Engine_Torque_Limit_State	---		

35. Torque Parameter Determination (TQP)

Filtered_Engine_Speed	RPM	Coolant_Torque_Adjustment	FT*LB
TQM_Final_Torque_Cmd	FT*LB	Friction_Torque	FT*LB
Total_Fueling	MG/STROKE	Net_Machine_Torque	FT*LB
AC_Torque	FT*LB	No_Load_Torque	FT*LB
Fan_Torque	FT*LB	Zero_Fuel_Torque	FT*LB
CHP_Pumping_Torque_Adj	FT*LB		
Net_Engine_Torque	FT*LB		
Coolant_Tmptr	DEG_F		

CM870 COMMON APPROACH TO CONTROL SYSTEM DIAGNOSTICS

Performance Diagnostics:

63. Charge Flow Derates [Charge Limit Manager (CHL)]

Filtered_Engine_Speed	RPM	Fueling_Control_State_Value	---
TQM_Final_Torque_Cmd	FT*LB	Charge_Press	IN_HG
Total_Fueling	MG/STROKE	Exhaust_Press	IN_HG

[CHL] Delta-P Derate Function:

EGR_Valve_Delta_Press	IN_HG	CHL_Derate_Is_Active	---
C_CHL_Delta_P_Drt_Limit	IN_HG	CHL_Delta_P_Drt_Active	---
C_CHL_Delta_P_Drt_Ratio	---	CHL_Delta_P_Drt_Offset	LB/MIN
Charge_Flow	LB/MIN	CHL_MCF_Cmd	LB/MIN
CHS_MCF_Cmd	LB/MIN	C_CHL_Delta_P_Drt_Fil_Cnst	---

[CHL] COT Derate Function:

Compressor_Outlet_Tmptr	DEG_F	CHL_Derate_Is_Active	---
C_CHL_COT_Drt_Limit	DEG_F	CHL_COT_Drt_Active	---
C_CHL_COT_Drt_Ratio	---	CHL_COT_Drt_Offset	LB/MIN
Charge_Flow	LB/MIN	CHL_MCF_Cmd	LB/MIN
CHS_MCF_Cmd	LB/MIN	C_CHL_COT_Drt_Fil_Cnst	---

[CHL] Turbo Speed Derate Function:

Compressor_Inlet_Density	LBM/FT3	CHL_Derate_Is_Active	---
Filtered_Turbo_Speed	KRPM	CHL_Turbo_Speed_Drt_Active	---
CHL_Turbo_Drt_Limit	KRPM	CHL_Turbo_Speed_Drt_Offset	LB/MIN
C_CHL_Turbo_Drt_Ratio	---	CHL_MCF_Cmd	LB/MIN
Charge_Flow	LB/MIN	C_CHL_Turbo_Drt_Fil_Cnst	---
CHS_MCF_Cmd	LB/MIN		

64. Oxygen / Fuel Control (OFC) Fuel Limit

Filtered_Engine_Speed	RPM	CBR_Fuel_Ref	MG/STROKE
TQM_Final_Torque_Cmd	FT*LB	CBR_FCLR_Ref	---
Total_Fueling	MG/STROKE	CBR_FCLR_On	---
Fueling_Control_State_Value	---	CBR_FCLR_Off	---
OFC_Fuel_Limit	MG/STROKE	OFC_EGR_Disable	---
CBR_Gross_Fuel	MG/STROKE		

65. Exhaust Temperature (Texh) Fuel Limit

Filtered_Engine_Speed	RPM	Texh_Fuel_Limit	MG/STROKE
TQM_Final_Torque_Cmd	FT*LB	Exhaust_Metal_Tmptr	DEG_F
Total_Fueling	MG/STROKE	CBR_Gross_Fuel	MG/STROKE
Fueling_Control_State_Value	---	CBR_Fuel_Ref	MG/STROKE

66. Chi Determination

Filtered_Engine_Speed	RPM	CBR_Chi_Value	---
TQM_Final_Torque_Cmd	FT*LB	CBR_Chi_Desired	---
Total_Fueling	MG/STROKE	CBR_Chi_Source	---
Fueling_Control_State_Value	---	CBR_Alpha	---
Compressor_Inlet_Density	LBM/FT3	CBR_Protection_Chi_Flag	---
Coolant_Tmptr	DEG_F	T_CBR_Chi_Selective_Override	ENABLE / DISABLE
Alpha	---	C_CBR_Chi_Override_LowTable	---
EMM_Cap_EL_Cmd	---	C_CBR_Chi_Override_HighTable	---
EMM_Protection_State	---	T_CBR_Chi_User_Override	ENABLE / DISABLE
CBR_EGR_Off	---	C_CBR_Chi_Override_Value	---

CM870 COMMON APPROACH TO CONTROL SYSTEM DIAGNOSTICS

103. Surge Characterization

Air Handling Controller Induced Surge:

Filtered_Engine_Speed	RPM	CHS_MCF_Cmd	LB/MIN
FSS_Total_Fueling	MG/STROKE	CHL_MCF_Cmd	LB/MIN
Fueling_Control_State_Value	---	Charge_Flow	LB/MIN
Filtered_Turbo_Speed	KRPM	CBL_EGR_Frac_Cmd	---
Compressor_Inlet_Tmptr	DEG_F	CHL_EGR_Frac_Cmd	---
Compressor_Outlet_Tmptr	DEG_F	EGR_Fraction	---
Charge_Tmptr	DEG_F	VGT_Duty_Cycle	%DutyCycle
Exhaust_Tmptr	DEG_F	TGC_VT_Cmd	%
Charge_Press	IN_HG	EGR_Position	%open
Compressor_Inlet_Press	IN_HG	EAC_EGR_Valve_Cmd	%open
Compressor_Inlet_Density	LBM/FT3	Fresh_Air_Flow	LB/MIN

Quasi-Steady State Compressor Surge:

Filtered_Engine_Speed	RPM	Compressor_Outlet_Tmptr	DEG_F
FSS_Total_Fueling	MG/STROKE	Compressor_Inlet_Density	LBM/FT3
Fueling_Control_State_Value	---	CBR_Chi_Value	---
Filtered_Turbo_Speed	KRPM	CBP_Air_Fuel_Ratio	---
Compressor_Inlet_Tmptr	DEG_F	EGR_Volumetric_Efficiency	---
Charge_Tmptr	DEG_F	EGR_Position	%open
CHL_EGR_Frac_Cmd	---	VGT_Duty_Cycle	%DutyCycle
EGR_Fraction	---		

Transient Compressor Surge:

Filtered_Engine_Speed	RPM	Boost_Pressure	IN_HG
FSS_Total_Fueling	MG/STROKE	Filtered_Turbo_Speed	KRPM
Fueling_Control_State_Value	---	Altitude	FT
Charge_Press	IN_HG	Charge_Flow	LB/MIN
Charge_Tmptr	DEG_F	CHS_MCF_Cmd	LB/MIN
Compressor_Inlet_Tmptr	DEG_F	CHL_MCF_Cmd	LB/MIN
Compressor_Inlet_Density	LBM/FT3	EGR_Position	%open
Compressor_Outlet_Tmptr	DEG_F	VGT_Duty_Cycle	%DutyCycle

Engine Surge:

Filtered_Engine_Speed	RPM	Effective_Gear_Ratio	---
FSS_Total_Fueling	MG/STROKE	Ndot_LSG	RPM/SEC
Fueling_Control_State_Value	---	Ndot_HSG	RPM/SEC
TQM_Final_Torque_Cmd	FT*LB	Ndot_Four_D	RPM/SEC
Ndot_Net_Torque_Cmd	FT*LB	Ndot_Cruise_Control	RPM/SEC
No_Load_Torque	FT*LB	Ndot_RSG	RPM/SEC
Ndot_Demand	RPM/SEC	Ndot_ASG	RPM/SEC
Ndot_Actual	RPM/SEC	Ndot_PTO	RPM/SEC

104. OFC and Texh Fuel Limits

Filtered_Engine_Speed	RPM	CBR_FCLR_On	---
FSS_Total_Fueling	MG/STROKE	CBR_FCLR_Off	---
Fueling_Control_State_Value	---	CBR_FCLR_Ref	---
OFC_Fuel_Limit	MG/STROKE	CBR_EGR_Disabled	---
Texh_Fuel_Limit	MG/STROKE	EGR_Position	%open
CBR_Fuel_Ref	MG/STROKE		
CBR_Gross_Fuel	MG/STROKE		

CLICK HERE TO **DOWNLOAD** THE COMPLETE MANUAL

- Thank you very much for reading the preview of the manual.
- You can download the complete manual from: www.heydownloads.com by clicking the link below



- Please note: If there is no response to CLICKING the link, please download this PDF first and then click on it.

CLICK HERE TO **DOWNLOAD** THE COMPLETE MANUAL

Engineering Features:

136. User Overrides

<u>USER OVERRIDE ENABLES:</u>	<u>OVERRIDES:</u>	<u>USER OVERRIDE VALUES:</u>	
User_Override_Fueling_Enable	Total_Fueling	User_Override_Fueling	MG/STROKE
T_CBR_Fuel_Ref_User_Override	CBR_Fuel_Ref	C_CBR_Fuel_Ref_Override_Value	MG/STROKE
T_CBL_Fuel_User_Override	CBL_Fuel_Cmd	C_CBL_Fuel_Override_Value	MG/STROKE
T_OFC_Fuel_Limit_User_Override	OFC_Fuel_Limit	C_OFC_Fuel_Limit_Override_Value	MG/STROKE
User_Override_Timing_Enable	Final_Timing	User_Override_Timing	CRANK_DEG
T_CBL_SOI_User_Override	CBL_SOI_Cmd	C_CBL_SOI_Override_Value	CRANK_DEG
T_CBL_SOI_Increment_Enable	CBL_SOI_Ref	C_CBL_SOI_Increment	CRANK_DEG
User_Commanded_Torque_Enable	Ndot_Net_Torque_Cmd	User_Commanded_Torque	FT*LB
Alpha_User_Override_Enable	Alpha	User_Override_Alpha	---
T_CBR_Alpha_User_Override	CBR_Alpha	C_CBR_Alpha_Override_Value	---
T_CBR_Chi_User_Override	CBR_Chi_Value	C_CBR_Chi_Override_Value	---
T_CBR_Chi_Selective_Override	CBR_Chi_Value	C_CBR_Chi_Override_Value	---
T_CBL_EGR_Frac_User_Override	CBL_EGR_Frac_Cmd	C_CBL_EGR_Frac_Override_Value	---
T_CBL_MCF_User_Override	CBL_MCF_Cmd	C_CBL_MCF_Override_Value	LB/MIN
T_CSE_Xform_User_Override	CSE_Xform_Angle	C_CSE_Xform_Override_Value	DEG
T_EGA_Cmd_User_Override	EGA_Position_Cmd_Final	C_EGA_Cmd_Override_Value	%open
T_EGA_PWM_User_Override	EGA_PWM_Limited	C_EGA_PWM_Override_Value	%DutyCycle
VGT_Duty_Cycle_Override_Enable	VGT_Duty_Cycle	VGT_Duty_Cycle_Override	%DutyCycle

137. Torque To Fuel Conversion

<u>Inputs to Fuel System Controls (Command):</u>		<u>Output from Fuel System Controls (Feedback):</u>	
Filtered_Engine_Speed	RPM	FSI_q_totalFueling_v	MG/STROKE
Total_Fueling	MG/STROKE	FSS_Total_Fueling	MG/STROKE
Fueling_Control_State	---	CBP_Adj_Total_Fueling	MG/STROKE
Ndot_Net_Torque_Cmd	FT*LB	Charge_Flow	LB/MIN
Ndot_Integral_Torque	FT*LB	CBP_Adj_Charge_Flow	LB/MIN
TQM_Final_Torque_Cmd	FT*LB	CBP_Combustion_Torque	FT*LB
TQM_Engine_Torque_Limit	FT*LB	CBP_EB_Torque	FT*LB
TQM_Machine_Torque_Limit	FT*LB	Net_Engine_Torque	FT*LB
CBR_Gross_Fuel	MG/STROKE	Net_Machine_Torque	FT*LB
CBR_Fuel_Ref	MG/STROKE	No_Load_Torque	FT*LB

138. Keyon Pressure Check Diagnostics

Keyswitch	---	Ambient_Air_Press_Sensor_Tolerance	IN_HG
Air_Pressure_Sensor_Raw	CNTS	Charge_Press_Sensor_Tolerance	IN_HG
Boost_Pressure_Absolute_Raw	CNTS	Exhaust_Press_Sensor_Tolerance	IN_HG
Exhaust_Pressure_Sensor_Raw	CNTS	Oil_Press_Sensor_Tolerance	PSI_A
Oil_Pressure_Absolute_Raw	CNTS	C_EGR_DP_IR_Startup_Pos_Thd	%open
Ambient_Air_Press	IN_HG	C_EGR_DP_IR_Startup_Press_Thd	IN_HG
Charge_Press	IN_HG	Air_Pressure_Keyon_Error	---
Exhaust_Press	IN_HG	Charge_Pressure_Keyon_Error	---
Oil_Press	PSI	Exhaust_Pressure_Keyon_Error	---
EGR_Delta_Press	IN_HG	Oil_Pressure_Keyon_Error	---
C_EGR_DP_IR_Startup_Delay_Time	SEC	EGR_Delta_Press_Keyon_Error	---

139. General Engine Protection (EPF)

Filtered_Engine_Speed	RPM	Compressor_Outlet_Tmptr	DEG_F
Total_Fueling	MG/STROKE	Coolant_Level	VOLT
TQM_Final_Torque_Cmd	FT*LB	Coolant_Tmptr	DEG_F
Fueling_Control_State	---	Oil_Level_Sensor	GAL
Throttle_100_Torque	FT*LB	EGR_Orifice_Tmptr	DEG_F
Engine_Protection_Derate_Torque	FT*LB	Exhaust_Metal_Tmptr	DEG_F
EPF_Torque_Limit_Status	---	Charge_Tmptr	DEG_F
EPF_Max_Torque_Limit_Index	---	Oil_Press	PSI
		Oil_Tmptr	DEG_F

CM870 COMMON APPROACH TO CONTROL SYSTEM DIAGNOSTICS

163. Cruise Control With AutoResume

Time:	0.2 sec	Filtered_Engine_Speed	Road_Speed
Monitor		Total_Fueling	Cruise_Control_Status
		Fueling_Control_State_Value	CC_Error
Time:	0.4 sec	Ndot_Net_Torque_Cmd_State	Cruise_Control_Reference_Speed
Monitor		Cruise_Droop	CC_Error
		Total_Fueling	System_Switch_Status
		Fueling_Control_State_Value	Cruise_Control_Status
		Road_Speed	Cruise_Command_Mode

164. Engine Braking

Time:	0.2 sec	Filtered_Engine_Speed	Commanded_Throttle
Monitor		E_Brake_Status	Road_Speed
		Boost_Pressure	Total_Fueling
		Net_Engine_Torque	
Time:	0.4 sec	Filtered_Engine_Speed	Commanded_Throttle
Monitor		E_Brake_Status	Fueling_Control_State_Value
		EB_Driver_Level	Boost_Pressure
		Total_Fueling	Road_Speed
		Net_Engine_Torque	Ambient_Air_Press
Time:	0.5 sec	Filtered_Engine_Speed	Road_Speed
Monitor		E_Brake_Status	Charge_Tmptr
		EB_Driver_Level	System_Switch_Status
		Total_Fueling	Ambient_Air_Press
		Net_Engine_Torque	Coolant_Tmptr
		Commanded_Throttle	Oil_Press
		Fueling_Control_State_Value	Exhaust_Press
		Boost_Pressure	Charge_Flow

165. Low Power – Road Speed Governor

Time:	0.1 sec	Filtered_Engine_Speed	
Monitor		Total_Fueling	
		Road_Speed	
Time:	0.2 sec	Filtered_Engine_Speed	Total_Fueling
Monitor		Ndot_Net_Torque_Cmd_State	Commanded_Throttle
		Boost_Pressure	Road_Speed
Time:	0.4 sec	Filtered_Engine_Speed	Ndot_RSG
Monitor		Throttle_100_Torque	OFC_Fuel_Limit
		Fueling_Control_State_Value	OFC_EGR_Disable
		Total_Fueling	Road_Speed
		Commanded_Throttle	Boost_Pressure
		Ndot_Demand	

166. Low Power – Geardown Protection

Time:	0.1 sec	Filtered_Engine_Speed	
Monitor		Total_Fueling	
		Road_Speed	
Time:	0.2 sec	Filtered_Engine_Speed	Total_Fueling
Monitor		RSG_Reference_Speed	Commanded_Throttle
		Boost_Pressure	Road_Speed
		Gear_Down_Active	
Time:	0.4 sec	Filtered_Engine_Speed	Commanded_Throttle
Monitor		Cruise_RSG_Road_Speed	Filtered_Gear_Ratio
		Total_Fueling	User_Filtered_Gear_Ratio
		Fueling_Control_State_Value	Gear_Down_Gear_Ratio
		Ndot_Net_Torque_Cmd_State	Gear_Down_Active

CM870 COMMON APPROACH TO CONTROL SYSTEM DIAGNOSTICS

ENGINE OPERATING CONDITION (ALPHA/CHI) STATES:

Engine_State

State	Alpha Value	Enumeration
Engine_Stop_State	STOP	1
Engine_Crank_State	CRANK	2
Engine_Run_State	RUN	3
Engine_Brake_State	ENGBRAKE	4
Engine_Overspeed_State	OVERSPED	5
Engine_Jumpstart_State	JUMPSTRT	6
Engine_Crank_Reentry_State	REENTRY	7
Engine_Shutdown_State	SHUTDOWN	8

Alpha

CBR_Alpha

State	Alpha Value	Enumeration
Urban Mode / Transient	URBAN	0
On-Highway / Steady State	OPEN_ROAD	1

Alpha_State

State	Alpha Value	Enumeration
Base	BASE	0
User	USER	1
Altitude_Derate	ALTITUDE	2
Engine_Protection	EPF	3
Slave_State	SLAVE	4
ESP_Alpha	ESP	5

CBR_Chi_Value

State	Alpha Value	Enumeration
Chi 1: Steady State	CHI 1	1
Chi 2: AECD Region II	CHI 2	2
Chi 3: AECD Region III	CHI 3	3
Chi 4: EGR Off	CHI 4	4

CBR_Chi_Source

State	Alpha Value	Enumeration
CBR_DENSITY_CHI	DENS_CHI	1
CBR_EXHAUST_CHI	EXH_CHI	2
CBR_COOLANT_CHI	COOL_CHI	3
CBR_EGR_OFF_CHI	EGR_OFF_CHI	10
USER_OVERRIDE_SOURCE	OVERRIDE	11
CBR_FULL_USER_OVERRIDE_CHI	FULL_OD	12
CBR_SINGLE_USER_OVERRIDE_CHI	SINGLE_OD	13
CBR_PROTECTION_CHI	PROTECT_CHI	14

ESP_Tau_State

State	Alpha Value	Enumeration
Normal	NORMAL	0
Reverse	REVERSE	1
Steep Grade	STEEP_GRADE	2

CM870 COMMON APPROACH TO CONTROL SYSTEM DIAGNOSTICS

ANTI-THEFT STATES:

Anti_Theft_State

State	Alpha Value	Enumeration
Unlocked_While_Stopped	STOP_UNLOCK	0
Locked_While_Running	RUN_LOCK	1
Unlocked_While_Running	RUN_UNLOCK	2
Tampered_With_Vehicle	TAMPER	3
Locked_While_Stopped	STOP_LOCK	4

AT_Password_State

State	Alpha Value	Enumeration
No_Entry	NO_ENTRY	0
Good_Entry	GOOD_ENTRY	1
Bad_Entry	BAD_ENTRY	2

AT_Engine_Lock_State

AT_Engine_Lock_State_Request

State	Alpha Value	Enumeration
Unlocked	FALSE	0
Locked	TRUE	1

JCOMM ANTI-THEFT STATES:

Jcomm_AT_Command_State

State	Alpha Value	Enumeration
Add_Password	ADD_PASSWD	0
Delete_Password	DEL_PASSWD	1
Change_Password	CHG_PASSWD	2
Lock_Or_Unlock	LOCK_UNLOCK	3
Check_Status	CHECK	4
Login	LOGIN	5
Idle_State	IDLE	6
IBZ_Idle_State	IBZ_IDLE	7

Jcomm_AT_Component_Status

State	Alpha Value	Enumeration
Unlocked	UNLOCK	0
Locked	LOCK	1
Blocked	BLOCK	2

Jcomm_AT_Desired_Exit_Mode

State	Alpha Value	Enumeration
Lock_Upon_Operator_Request	LOCK_RQST	0
Lock_When_Key_Off	LOCK_KEYOFF	1
Not_Available	NOT_AVAIL	2

Jcomm_AT_Encryption_Indicator

State	Alpha Value	Enumeration
Encryption_Seed_Request	REQUEST	0
Encryption_Password_Present	PRESENT	1
Indicator_Not_Available	NOT_AVAIL	2

CM870 COMMON APPROACH TO CONTROL SYSTEM DIAGNOSTICS

CM870 Control System:

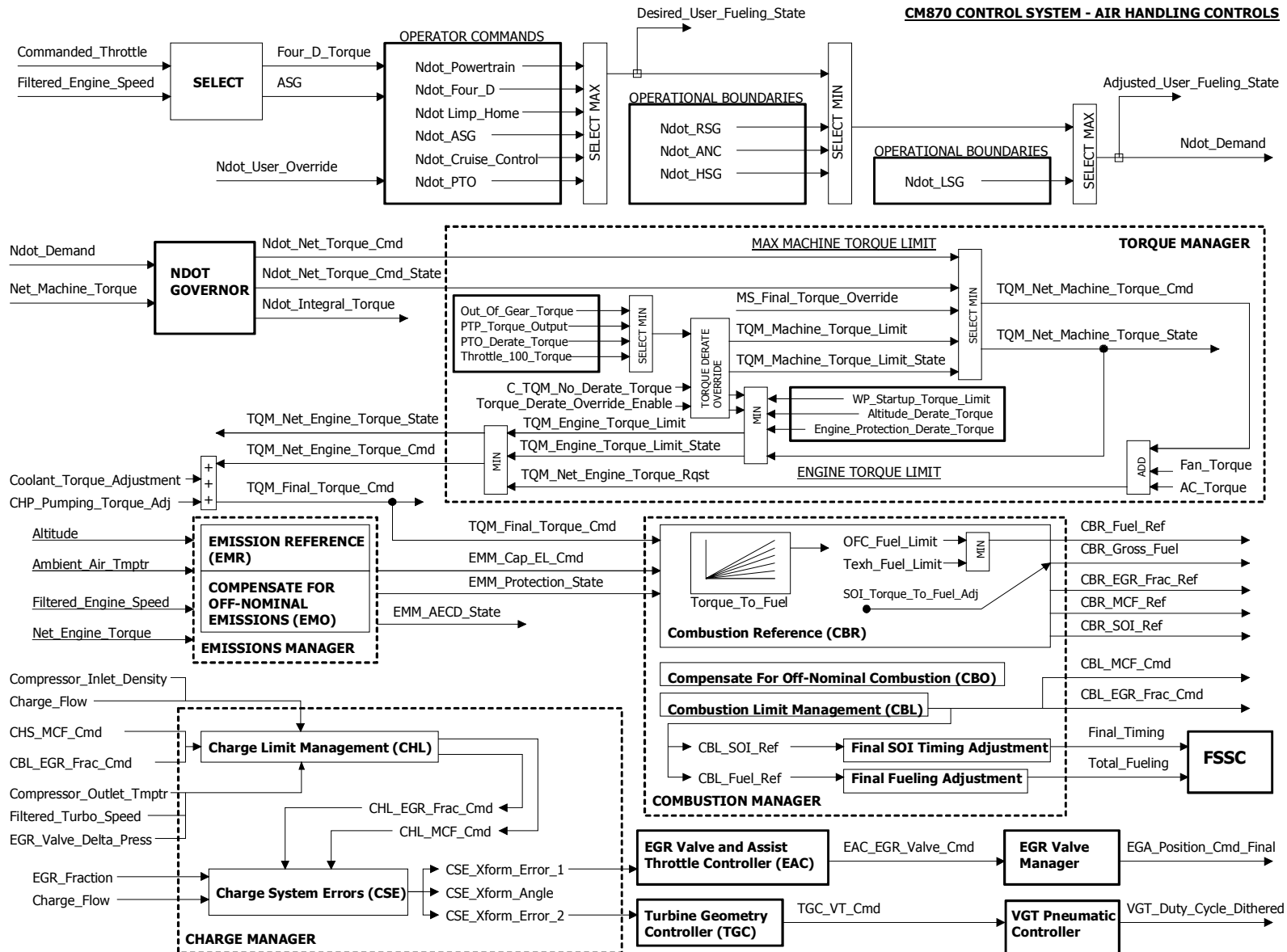

CM870 COMMON APPROACH TO CONTROL SYSTEM DIAGNOSTICS

Inlet Density Chi – Chi Value Determination (ISM '02 Beta Engines):

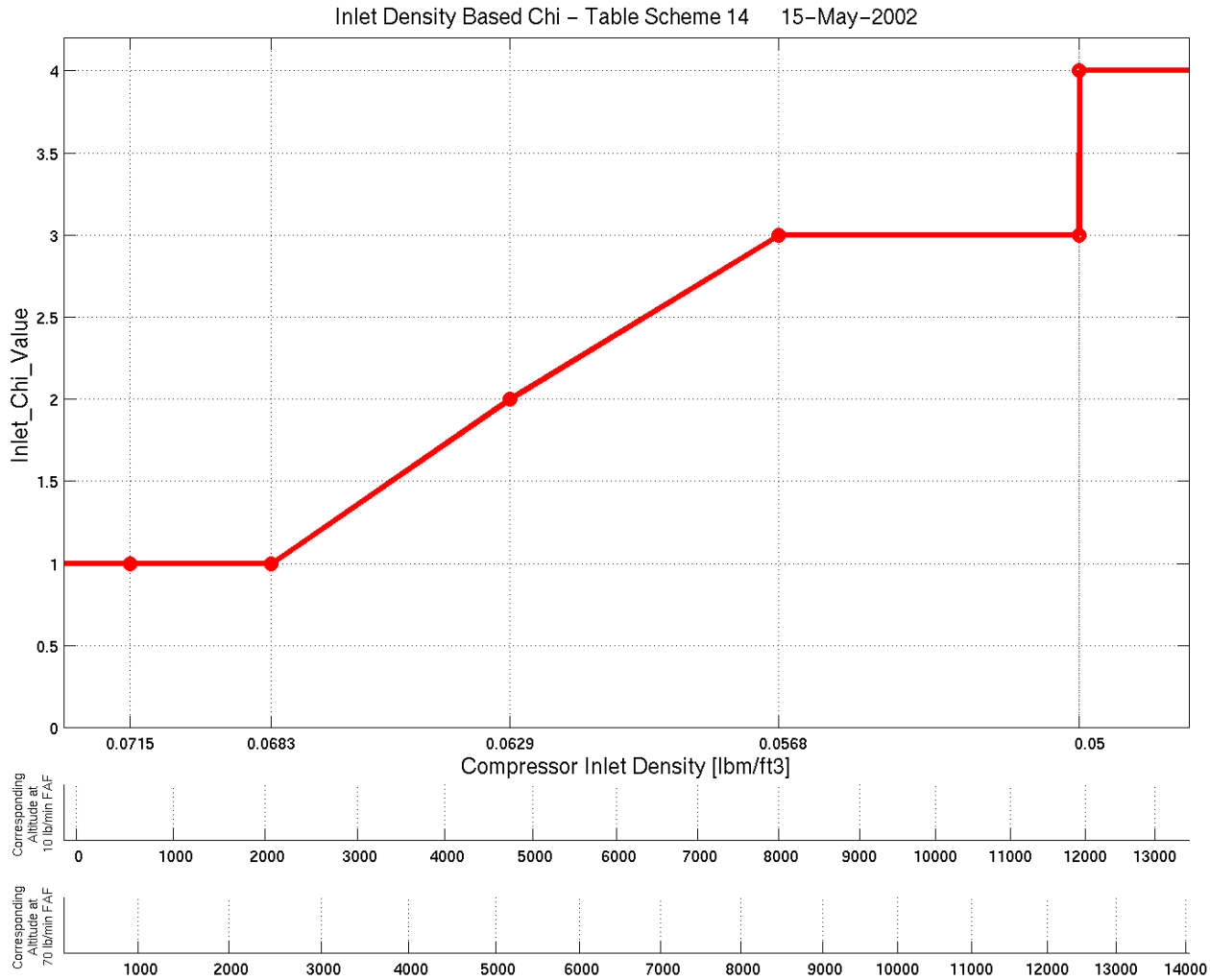

CLICK HERE TO **DOWNLOAD** THE COMPLETE MANUAL

- Thank you very much for reading the preview of the manual.
- You can download the complete manual from: www.heydownloads.com by clicking the link below



- Please note: If there is no response to CLICKING the link, please download this PDF first and then click on it.

CLICK HERE TO **DOWNLOAD** THE COMPLETE MANUAL