



circuit diagram

150100436 - 05 EN

Self-propelled forage harvester

BiG X 700, 850, 1100

from serial no. 780 000; from year of manufacture 2009

20.06.2012



CLICK HERE TO **DOWNLOAD** THE COMPLETE MANUAL

- Thank you very much for reading the preview of the manual.
- You can download the complete manual from: www.heydownloads.com by clicking the link below



- Please note: If there is no response to CLICKING the link, please download this PDF first and then click on it.

CLICK HERE TO **DOWNLOAD** THE COMPLETE MANUAL

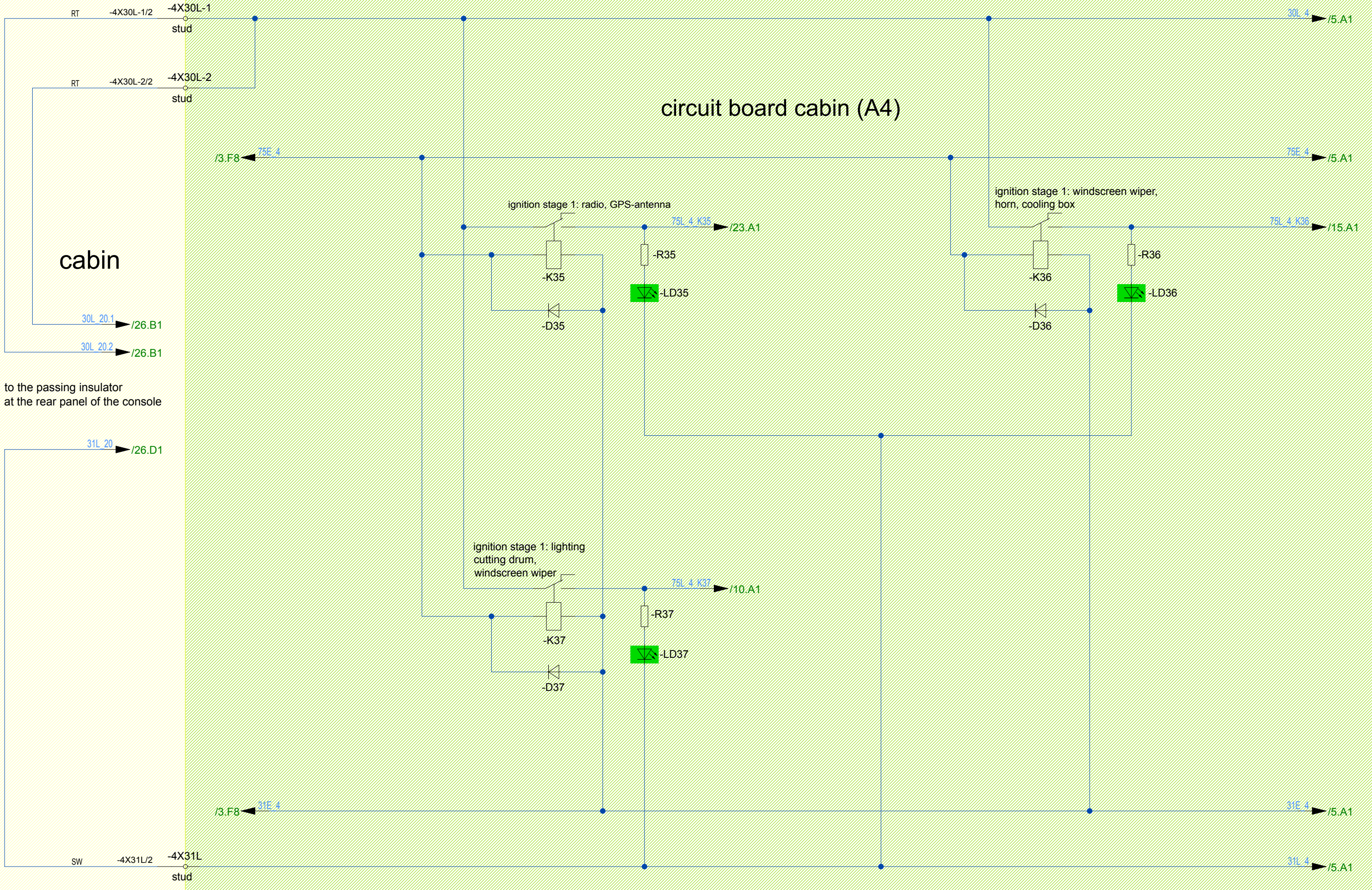

(C)				Created	16.04.2010
(B)				User	Schrameyer
(A)				Proved	
	change	date	name	Origin	Repl. f.



document-no.: D24 BiG X 700, 850, 1100
 150100436 - 05
 cabin: relay board ignition stage 1

plant	
location	
sheet	4
from	Sh.

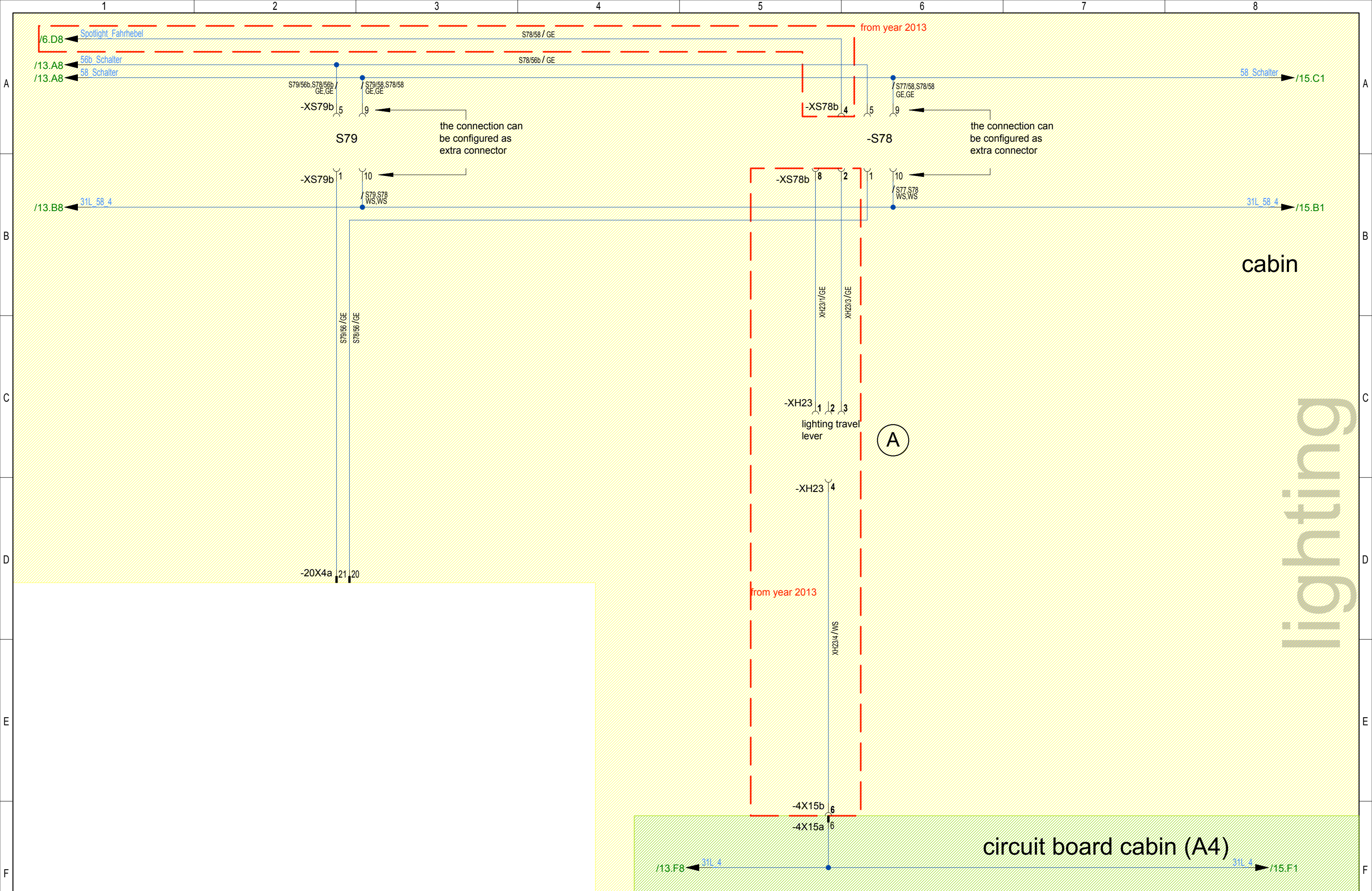

lighting

(C)				Created
(B)			date	14.06.2012
(A)	Beleuchtung Fahrhebel hinzu.	08.06.2012	Berns	User bernsf
	change	date	name	Proved



document-no.: **D24 BiG X 700, 850, 1100**
150100436 - 05
 cabin: reserve, spotlight travel lever

plant	
location	
sheet	14
from	Sh.

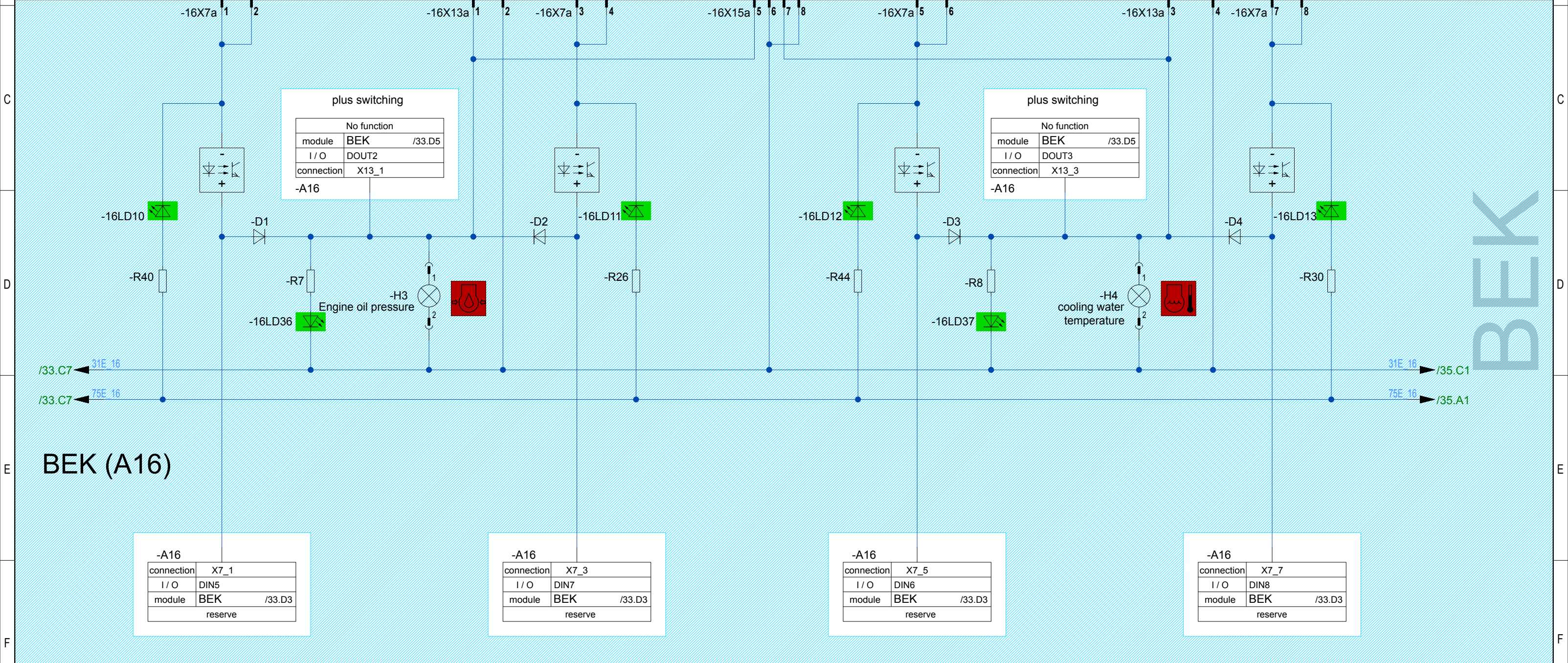
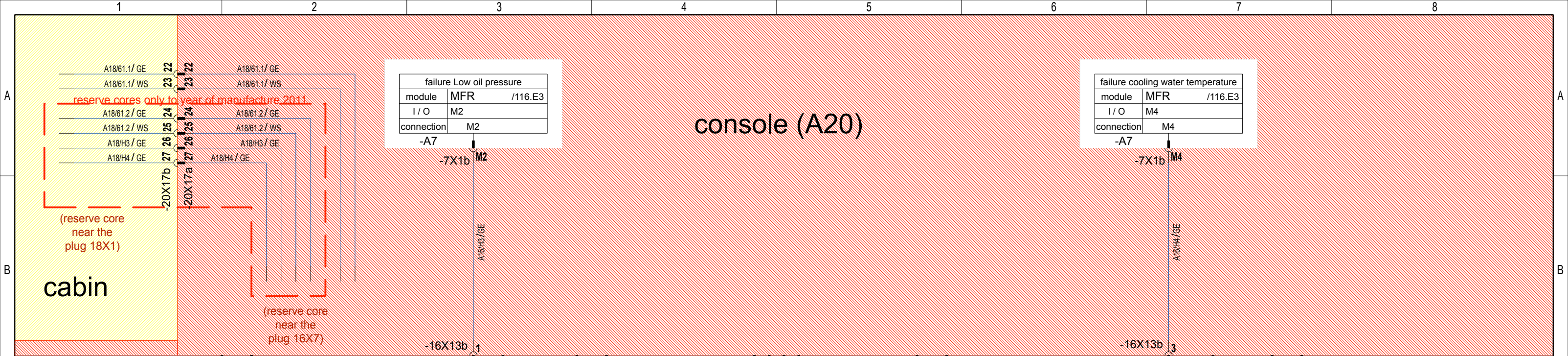

BEK

console (A20)

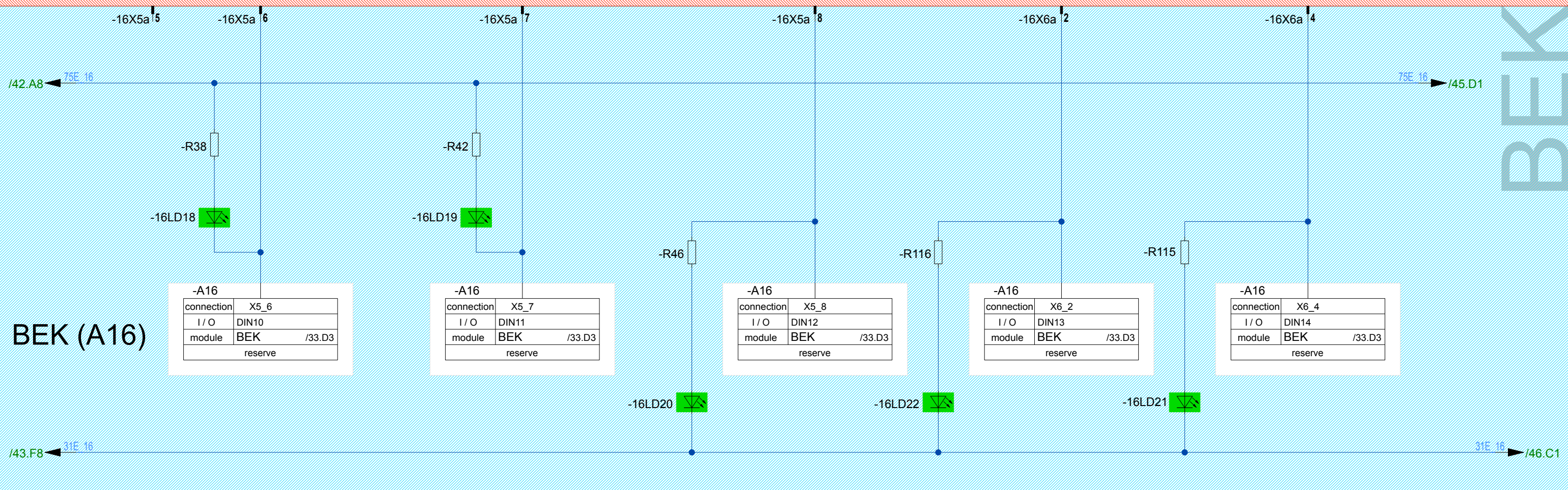

BEK (A16)

BEK

(C)				Created
(B)			date	16.04.2010
(A)			User	Schrammeyer
	change	date	name	Proved



document-no.: **D24 BiG X 700, 850, 1100**
150100436 - 05
 console: BEK: inputs: reserve Digital inputs

plant	
location	
sheet	44
from	Sh.

CLICK HERE TO **DOWNLOAD** THE COMPLETE MANUAL

- Thank you very much for reading the preview of the manual.
- You can download the complete manual from: www.heydownloads.com by clicking the link below



- Please note: If there is no response to CLICKING the link, please download this PDF first and then click on it.

CLICK HERE TO **DOWNLOAD** THE COMPLETE MANUAL

potential distributor board (A17)

console (A20)

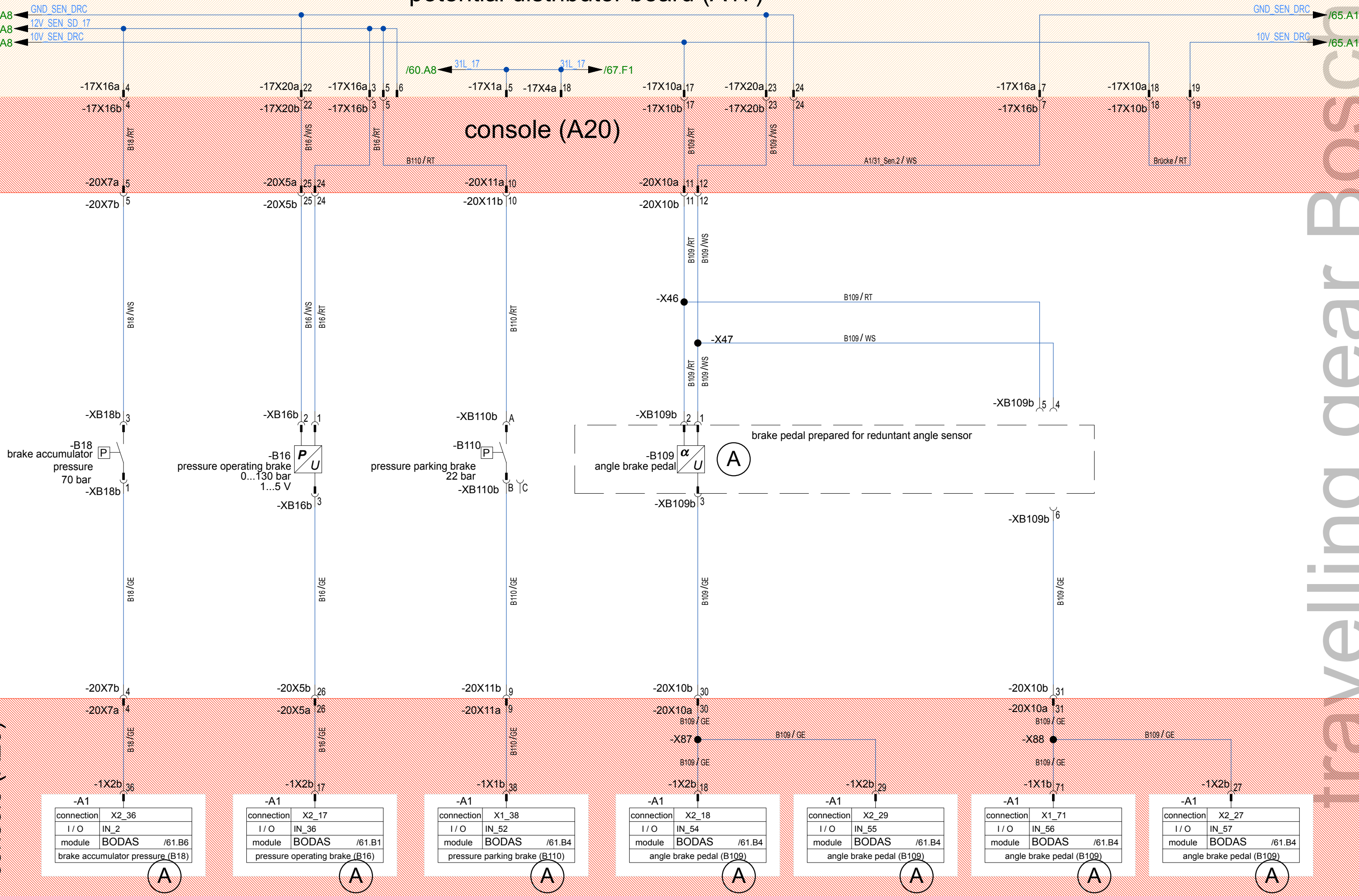

(C)				Created	
(B)			date	14.06.2012	
(A)	Anschlußnamen entfernt, BMK hinzugefügt	25.04.2012	Berns	User	bernsf
	change	date	name	Proved	



document-no.: **D24 BiG X 700, 850, 1100**
150100436 - 05
 travelling gear Bosch: inputs: brake accumulator pressure, pressure operating brake, pressure parking brake, Winkelsensor brake pedal

plant	
location	
sheet	64
from	Sh.

travelling gear Bosch

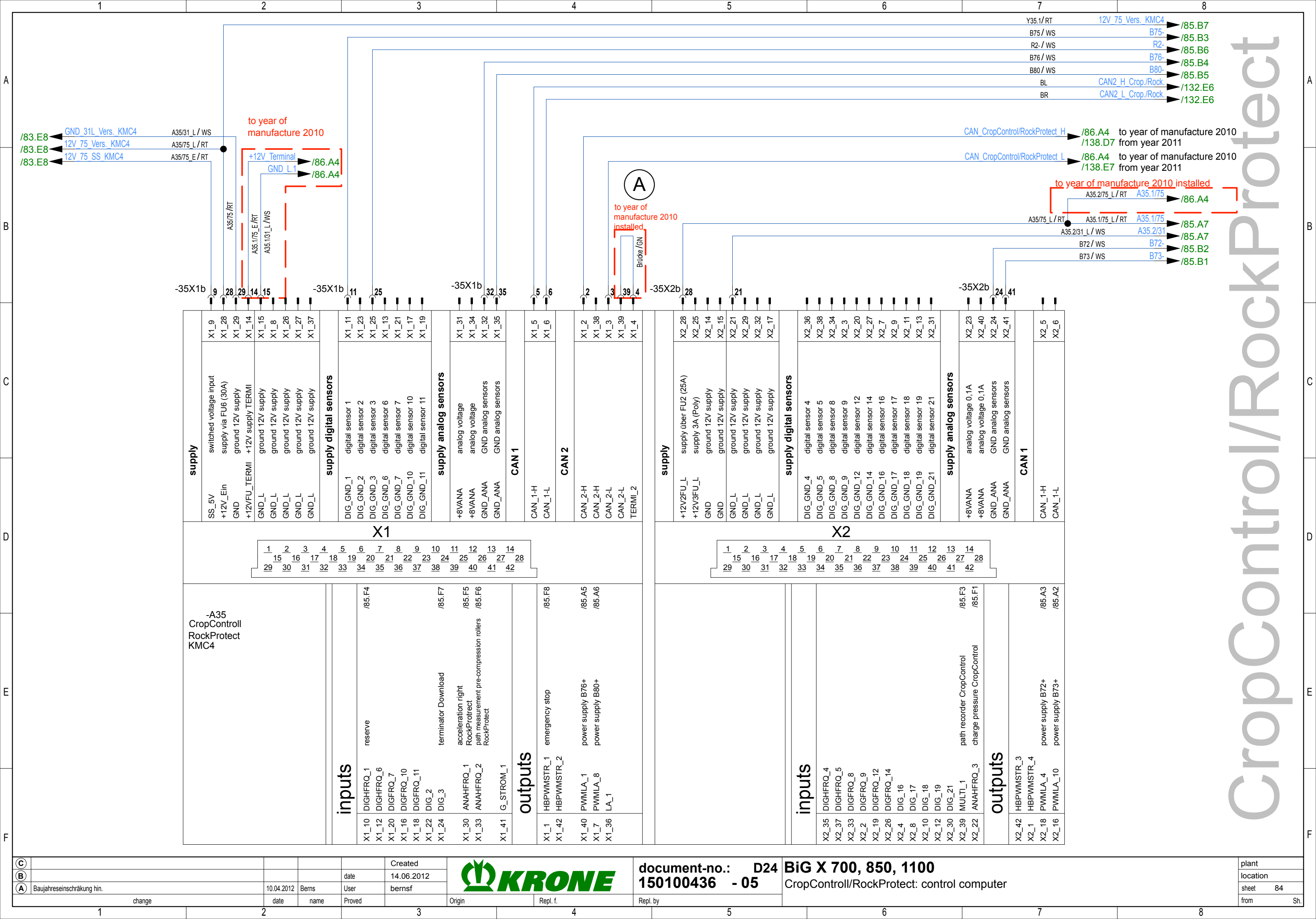

CropControl/RockProtect

(C)				Created
(B)			date	14.06.2012
(A)	Baujahreseinschränkung hin.	10.04.2012	Berns	User
	change	date	name	Proved



document-no.: **D24 BiG X 700, 850, 1100**
150100436 - 05
 CropControl/RockProtect: control computer

plant	
location	
sheet	84
from	Sh.

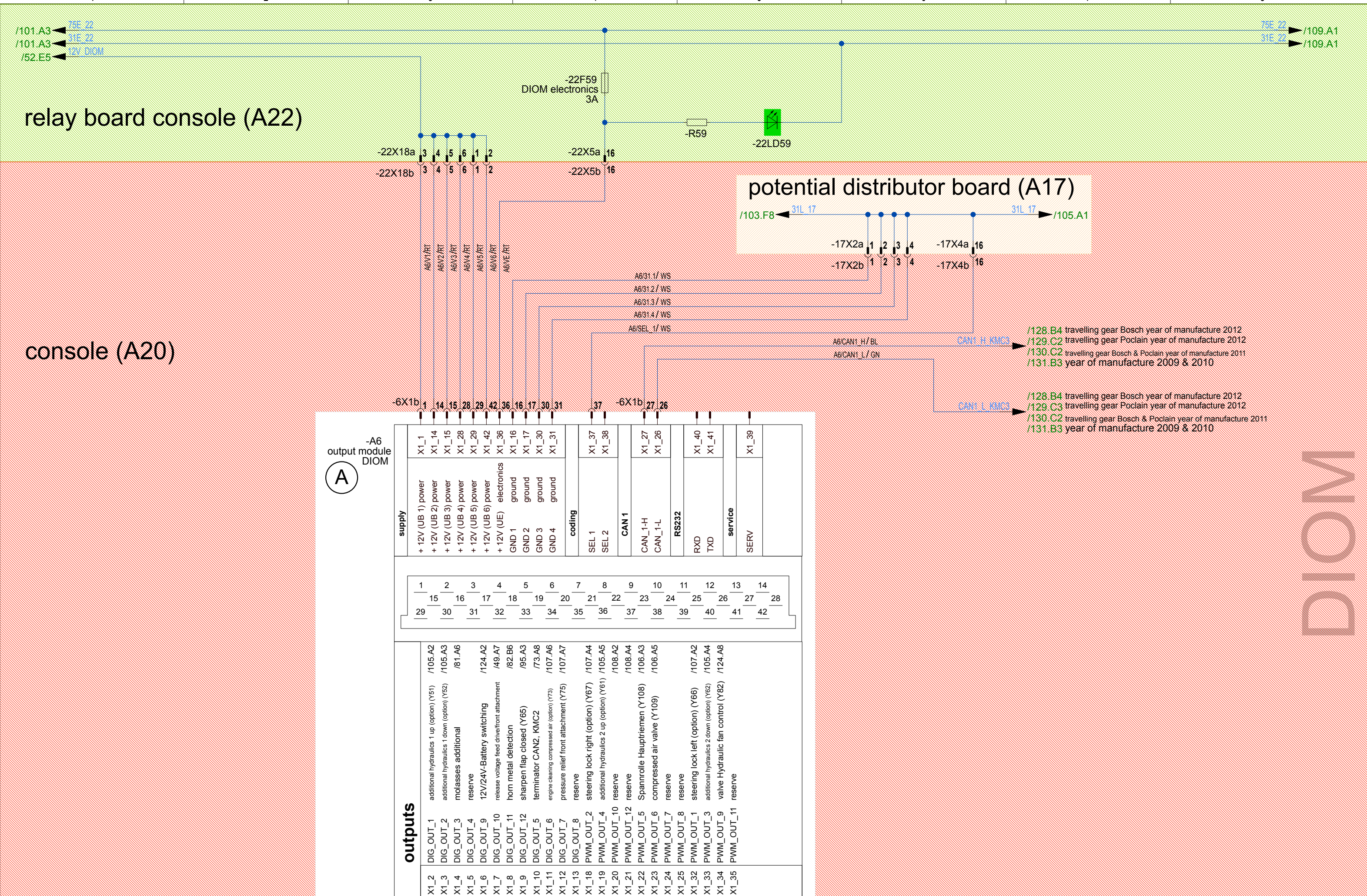

- /128.B4 travelling gear Bosch year of manufacture 2012
- /129.C2 travelling gear Poclain year of manufacture 2012
- /130.C2 travelling gear Bosch & Poclain year of manufacture 2011
- /131.B3 year of manufacture 2009 & 2010

- /128.B4 travelling gear Bosch year of manufacture 2012
- /129.C3 travelling gear Poclain year of manufacture 2012
- /130.C2 travelling gear Bosch & Poclain year of manufacture 2011
- /131.B3 year of manufacture 2009 & 2010

DIOM

(C)				Created	16.04.2010
(B)				date	
(A)	Sensor/Aktor BMK hinzugefügt	22.03.2012	Berns	User	Schrammeyer
	change	date	name	Proved	Origin



document-no.: **D24 BiG X 700, 850, 1100**
150100436 - 05
 DIOM (output module): power supply, overview

plant	
location	
sheet	104
from	Sh.

no function		
12V/24V-Battery switching		
module	DIOM	/104.E3
I/O	DIG_OUT_9	
connection	X1_6	

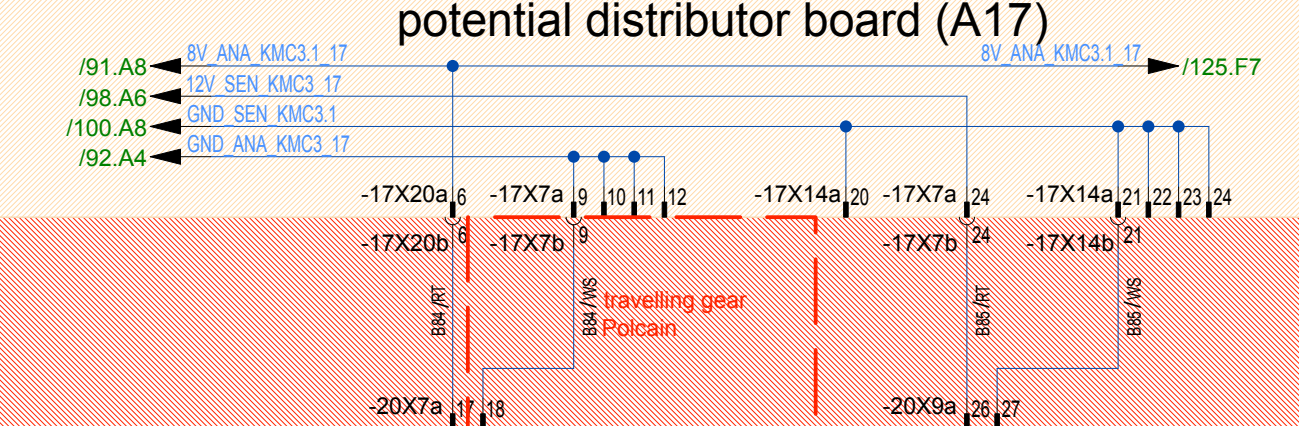

valve Hydraulic fan control (Y82)		
module	DIOM	/104.E5
I/O	PWM_OUT_9	
connection	X1_34	

console (A20)

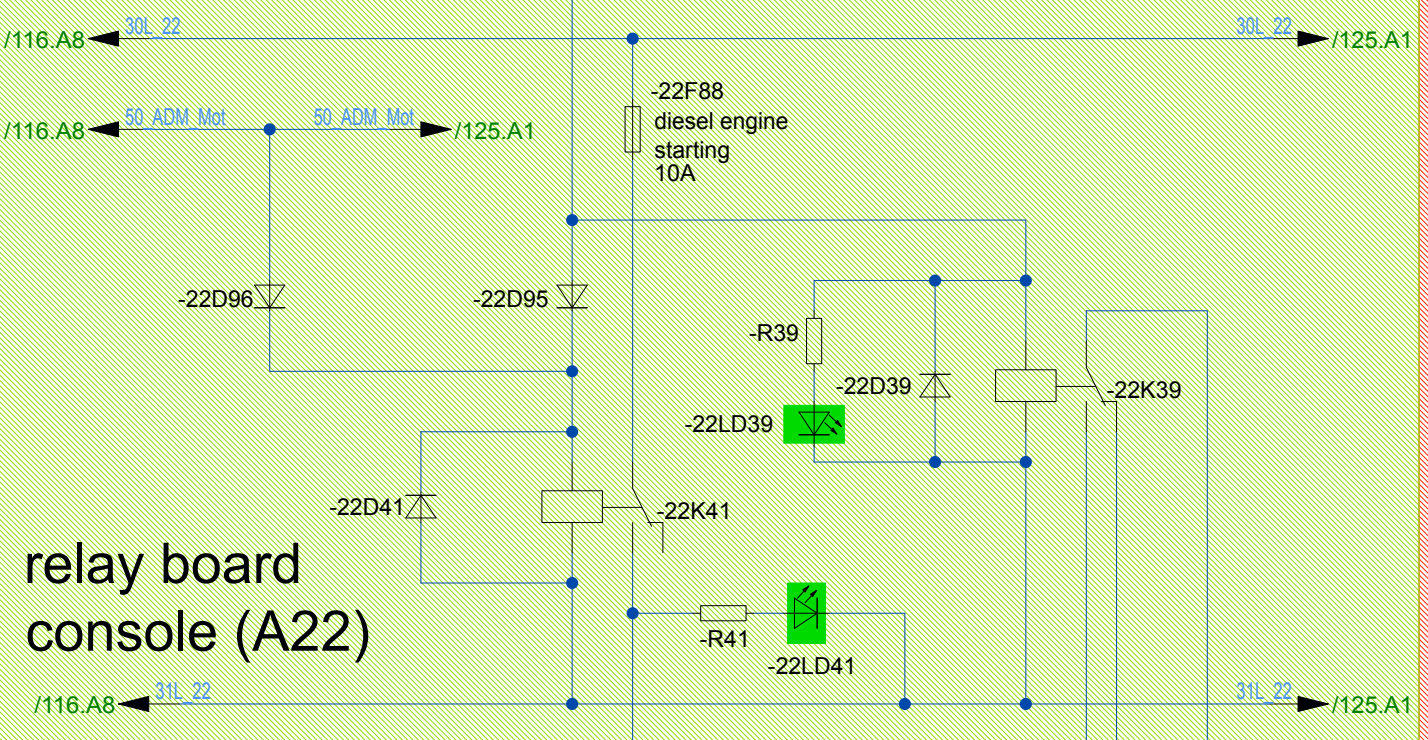

relay board console (A22)

console (A20)

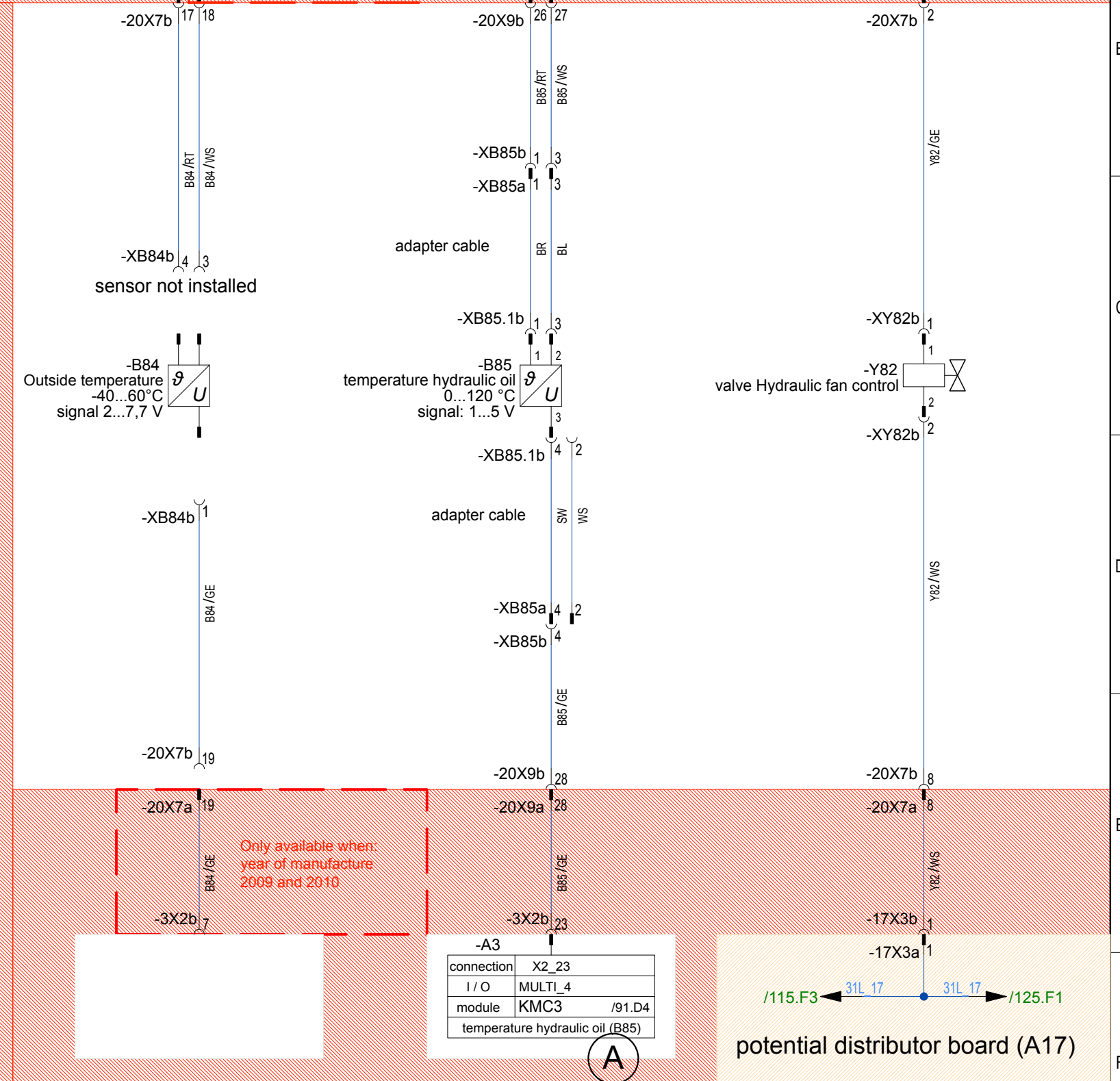
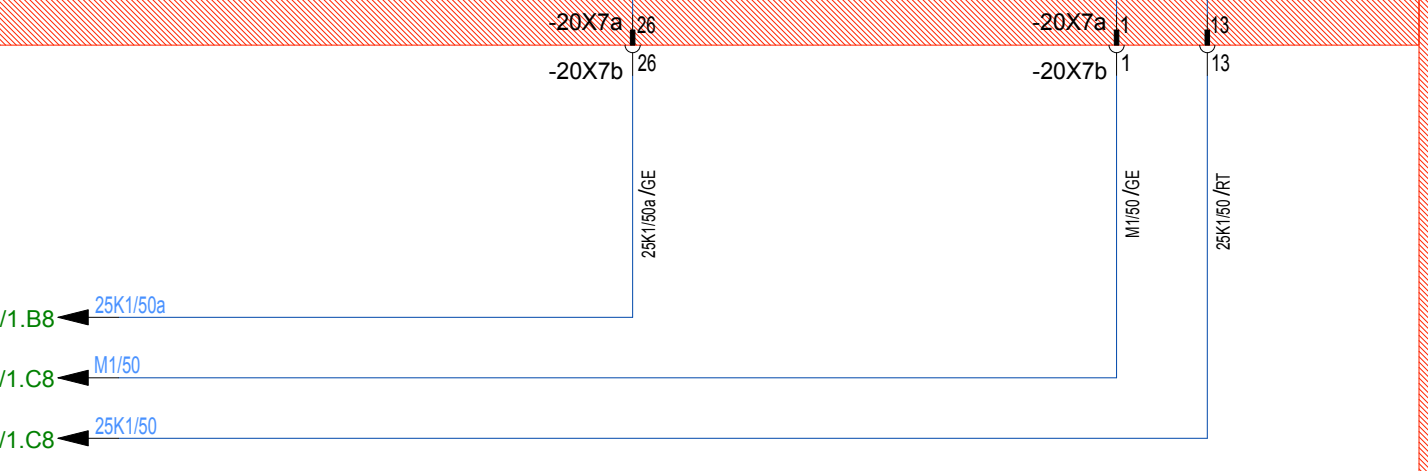

-A3		
connection	X2_23	
I/O	MULTI_4	
module	KMC3	/91.D4
temperature hydraulic oil (B85)		

potential distributor board (A17)

(C)				Created	16.04.2010
(B)				date	Schrameyer
(A)	BMK hinzugefügt	14.06.2012	Bernsf	User	
	change	date	name	Proved	Origin
					Repl. f.



document-no.: D24 BiG X 700, 850, 1100
150100436 - 05
DIOM: motor-start relay, valve Hydraulic fan control

plant	
location	
sheet	124
from	Sh.

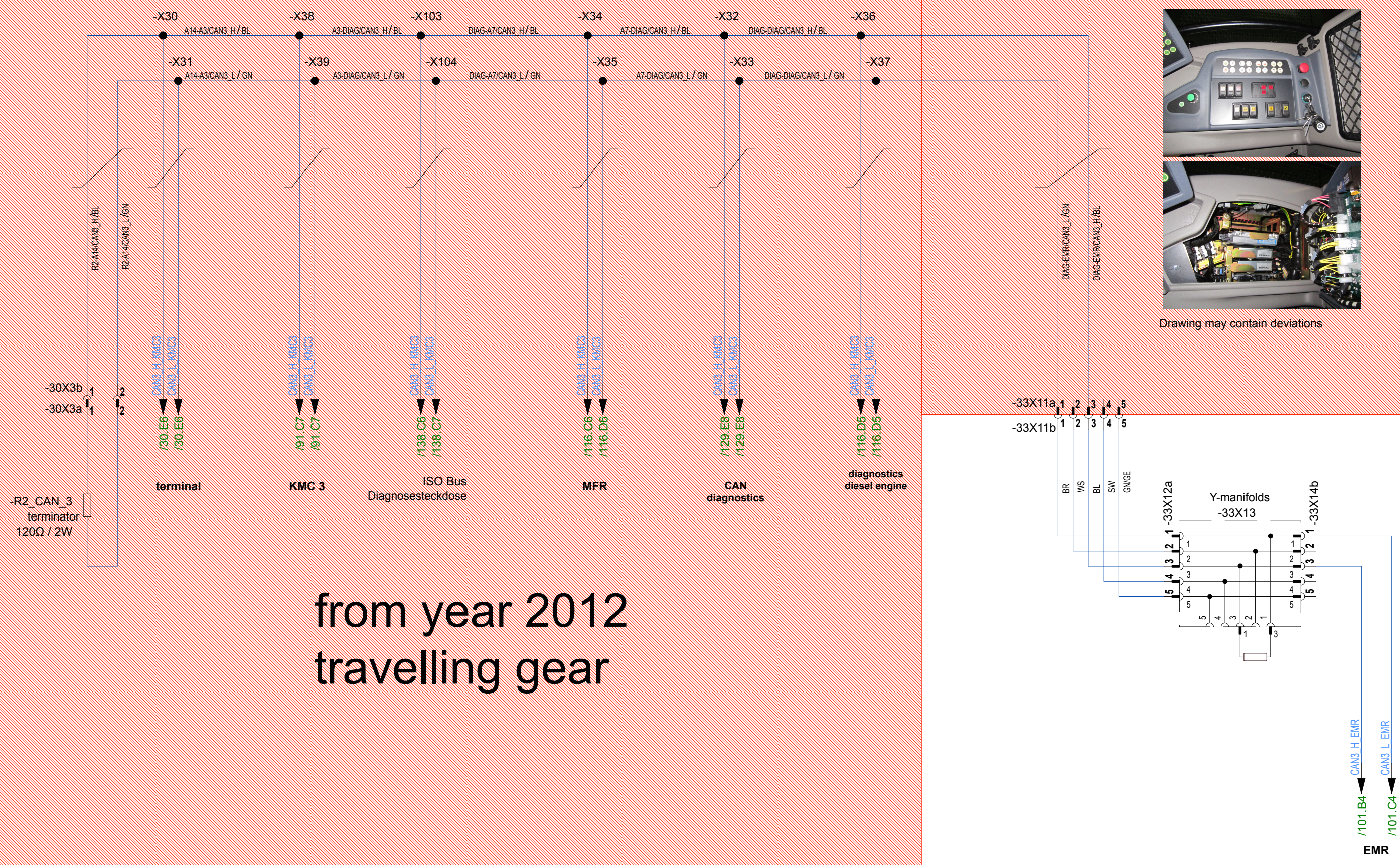

Drawing may contain deviations

from year 2012
travelling gear

CAN 3 overview

(C)				Created
(B)			date	14.06.2012
(A)			User	bernsf
	change	date	name	Proved



document-no.: D24 BiG X 700, 850, 1100
150100436 - 05
CAN3-bus-complete survey

plant	
location	
sheet	134
from	Sh.

CLICK HERE TO **DOWNLOAD** THE COMPLETE MANUAL

- Thank you very much for reading the preview of the manual.
- You can download the complete manual from: www.heydownloads.com by clicking the link below



- Please note: If there is no response to CLICKING the link, please download this PDF first and then click on it.

CLICK HERE TO **DOWNLOAD** THE COMPLETE MANUAL