

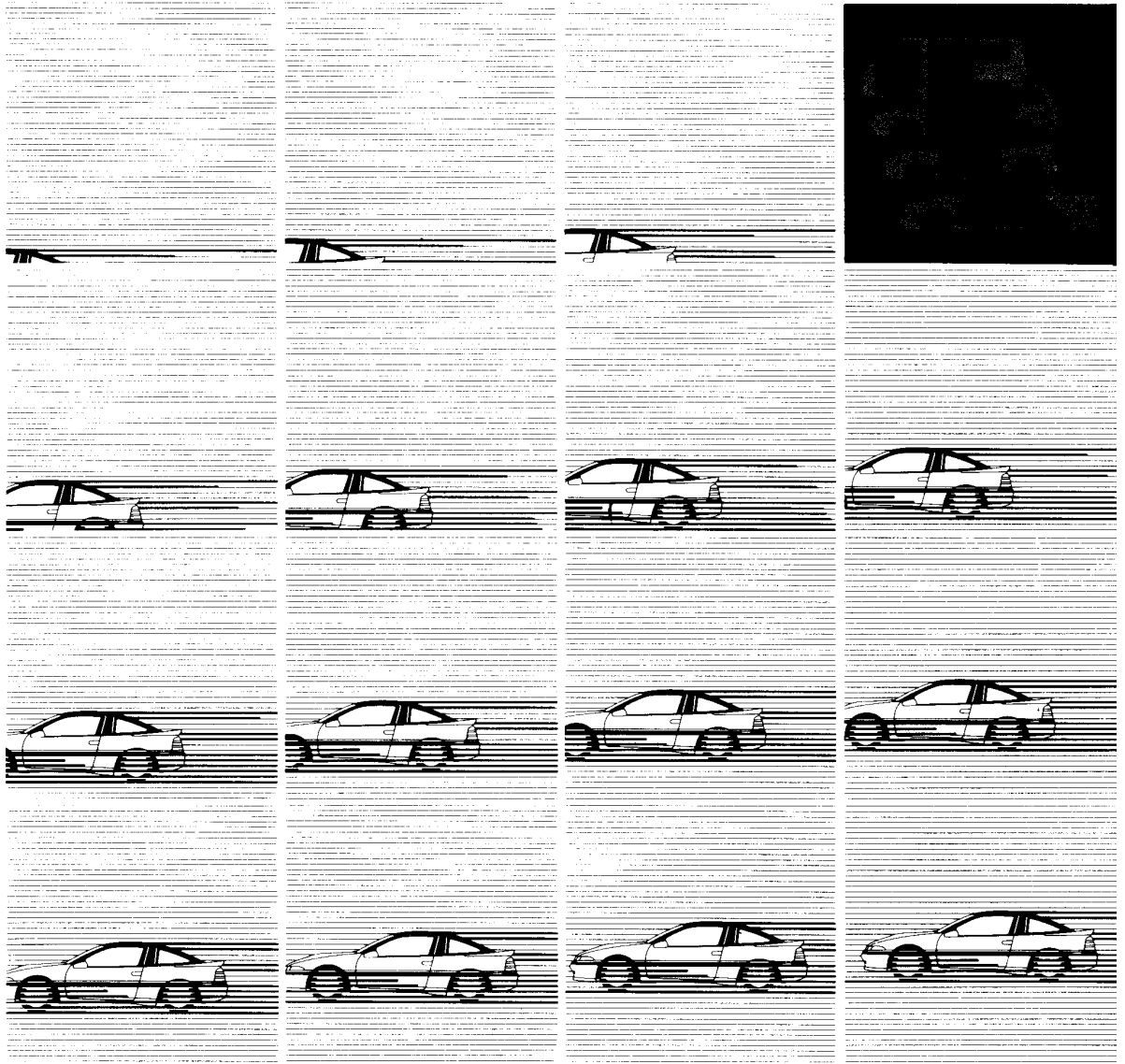

# Body Repair Manual

## ECLIPSE '91



Pub. No. PBUE9015

CLICK HERE TO **DOWNLOAD** THE COMPLETE MANUAL



- Thank you very much for reading the preview of the manual.
- You can download the complete manual from: [www.heydownloads.com](http://www.heydownloads.com) by clicking the link below



- Please note: If there is no response to CLICKING the link, please download this PDF first and then click on it.

CLICK HERE TO **DOWNLOAD** THE COMPLETE MANUAL

No.	Part name	Material	No.	Part name	Material			
1	Front door beltline reinforcement, outer	SGACC	48	Roof panel (for sun roof)	SGACE			
2	Front door, outer, rear		49	Front door inner panel				
3	Front door, inner, rear		50	Hood panel, inner				
4	Front fender bracket		51	Front fender panel				
5	Cowl top panel, outer		52	Tailgate panel, outer, upper				
6	Cowl top panel, inner		53	Tailgate panel, inner				
7	Front upper extension, inner		54	Front floor side sill, outer				
8	Roof drip channel		55	Rear wheelhouse, inner				
9	Rear wheelhouse front extension		56	Quarter panel, outer				
10	Roof drip channel extension		57	Quarter panel, inner, lower				
11	Rear pillar, outer		58	Rear lamp housing				
12	Fuel filler neck bracket		59	Front floor pan				
13	Fuel filler door panel		60	Rear end panel, inner				
14	Quarter outer lower extension		61	Front fender shield				
15	Rear lamp housing extension		62	Rear floor side sill				
16	Dash panel		SGACC	63		Center pillar, outer	SENCE	
17	Front floor side sill, inner, front			64		Spring house panel		
18	Dash panel extension			65		Backbone rear reinforcement		
19	Dash panel crossmember			66		Rear floor crossmember, lower		
20	Front floor sidemember			67		Rear floor pan		
21	Front floor side sill, inner			68		Strut house panel		
22	Front floor sidemember extension			69		Rear floor sidemember reinforcement		
23	Rear seat pan			70		Rear floor sidemember		
24	Rear end panel, outer			71		Front sidemember, rear		SENHC
25	Rear fascia upper bracket							
26	Front end upper bar reinforcement		72	Bumper bracket		SENC35R		
27	Turn lamp bracket			73			Front sidemember, inner	
28	Fender support plate			74			Front sidemember rear reinforcement	
29	Sidemember to crossmember brace		75	Lateral rod bracket		SENP38		
30	Headlamp support panel			76			Trailing arm bracket	
31	Oil cooler bracket		77	Front door panel, outer		SGAC35R		
32	Front end upper bar			78			Hood panel, outer	
33	Shield plate			79			Tailgate panel, outer, lower	
34	Front upper frame, inner			80			Front pillar, inner, upper (B)	
35	Front upper frame, lower			81			Front pillar, outer, upper	
36	Front upper frame, outer			82			Front pillar, outer, lower	
37	Rear floor side sill reinforcement			83			Front upper frame extension, outer	
38	Rear seat crossmember	84		Lateral rod reinforcement				
39	Rear floor crossmember reinforcement	85		Sidemember seat belt reinforcement				
40	Rear floor seat belt reinforcement	86		Rear floor sidemember extension				
41	Jack up reinforcement	87	Front pillar, inner, upper (A)	SPRC35				
42	Radiator bracket		88		Front pillar, inner, lower			
43	Front tie down bracket, inner		89		Spare tire bracket			
44	Rear floor sidemember front bulkhead	SGAHC						
45	Rear floor sidemember rear bulkhead							
46	Rear floor sidemember center reinforcement							
47	Rear tie down reinforcement							

\* SGACC  Galvannealed steel plate  
 SGACE   
 SGAHC   
 SENHC: SPHC plated with an electrical zinc-nickel alloy  
 SENCE: SPCE plated with an electrical zinc-nickel alloy  
 SPRC: Phosphorus added  
 SENC35R: SPRC35 plated with an electrical zinc-nickel alloy  
 SGAC35R: Galvannealed SPRC35  
 SENPH: SAPH plated with an electrical zinc-nickel alloy  
 The numbers in the material codes indicate the tensile strength.

(1) Front sidemember (Left side)  
 The following reinforcements have been installed to the front sidemember (Left side).

1. Front sidemember, inner
2. Front tie down bracket, inner
3. Front tie down bracket, outer
4. Absorber bracket
5. Front sidemember bulkhead
6. Front sidemember, outer
7. Pipe support, front
8. Front sidemember, rear
9. Pipe support, rear
10. Front sidemember rear reinforcement

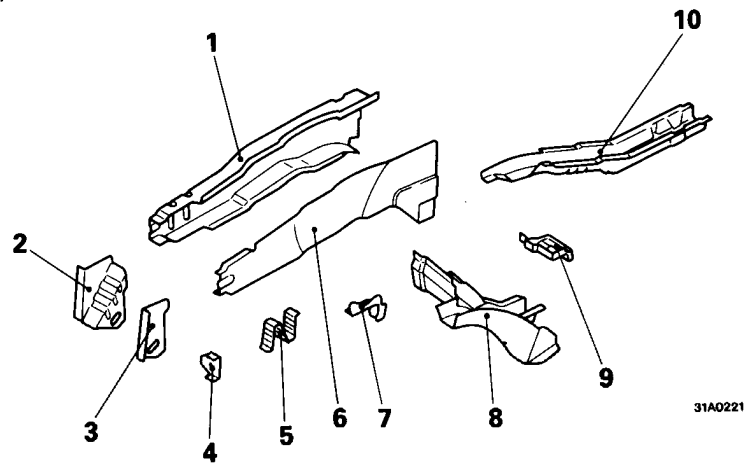

31A0221

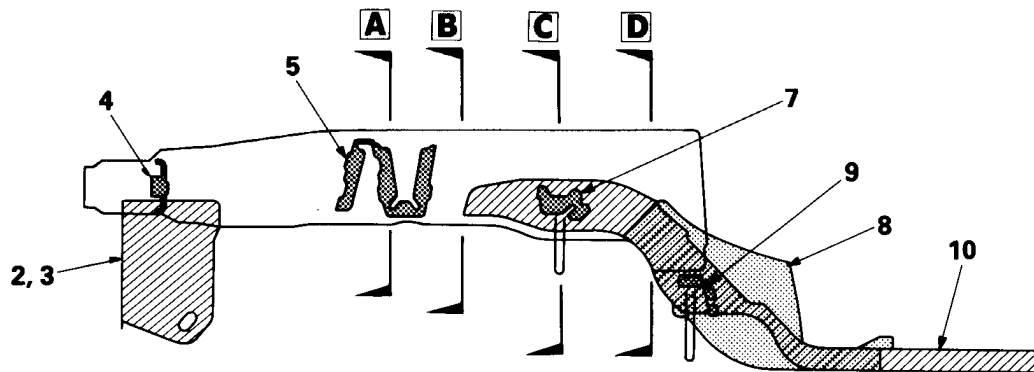

31A0182

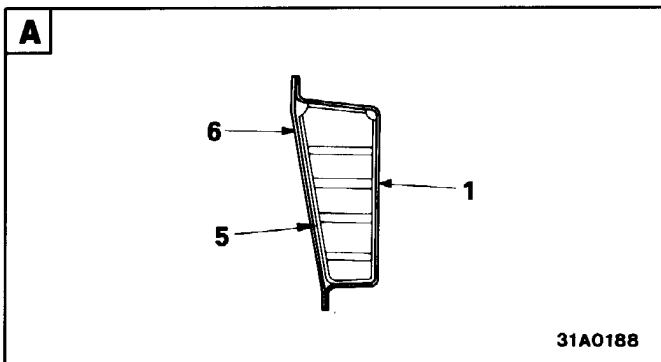

31A0188

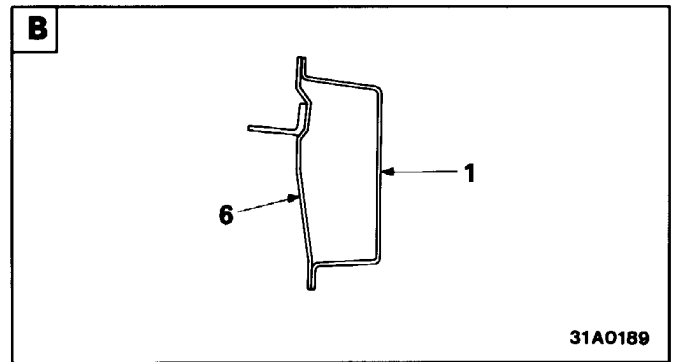

31A0189

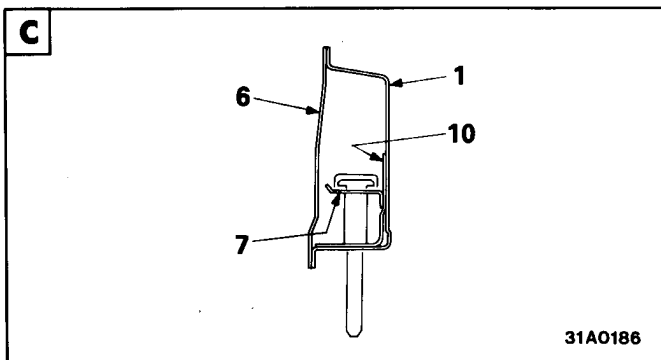

31A0186

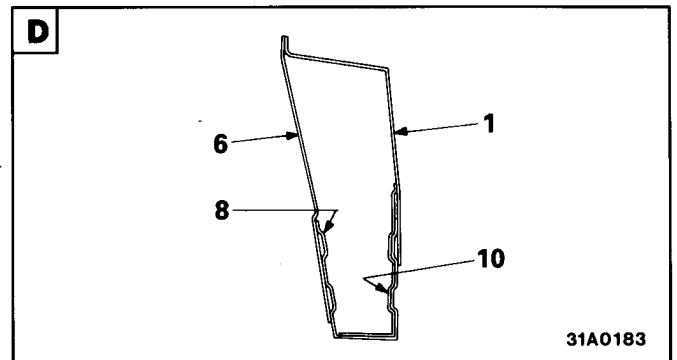

31A0183

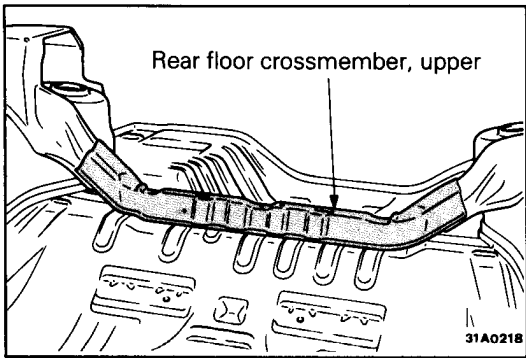

**Rear Floor Crossmember, Upper**

By providing a rear floor crossmember (upper) and coupling it with the side body, rigidity has been maintained and the spare tire is prevented from being pushed into the passenger compartment in a collision.

**ROOF**

A construction without the roof bow has been achieved by making the roof surface small and increasing the camber.

**(Vehicles without sun roof)**

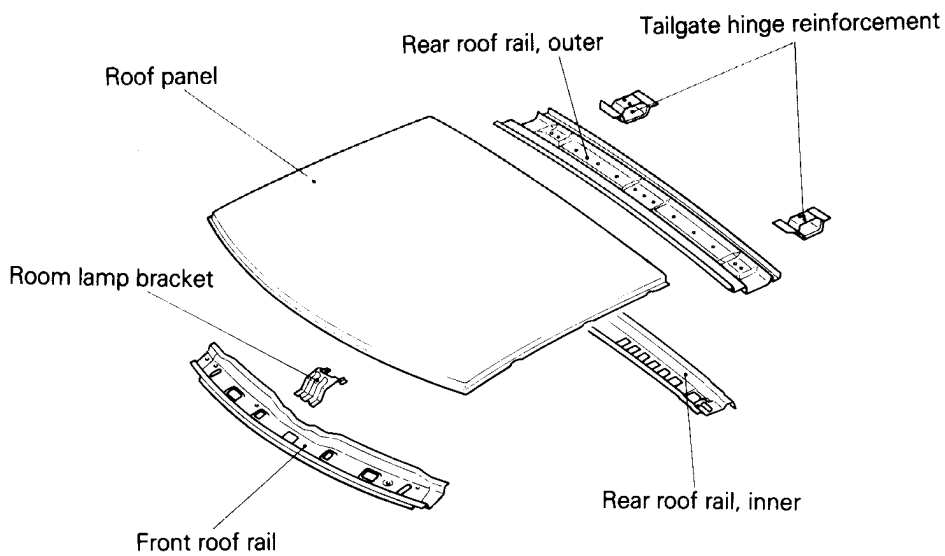

**(Vehicles with sun roof)**

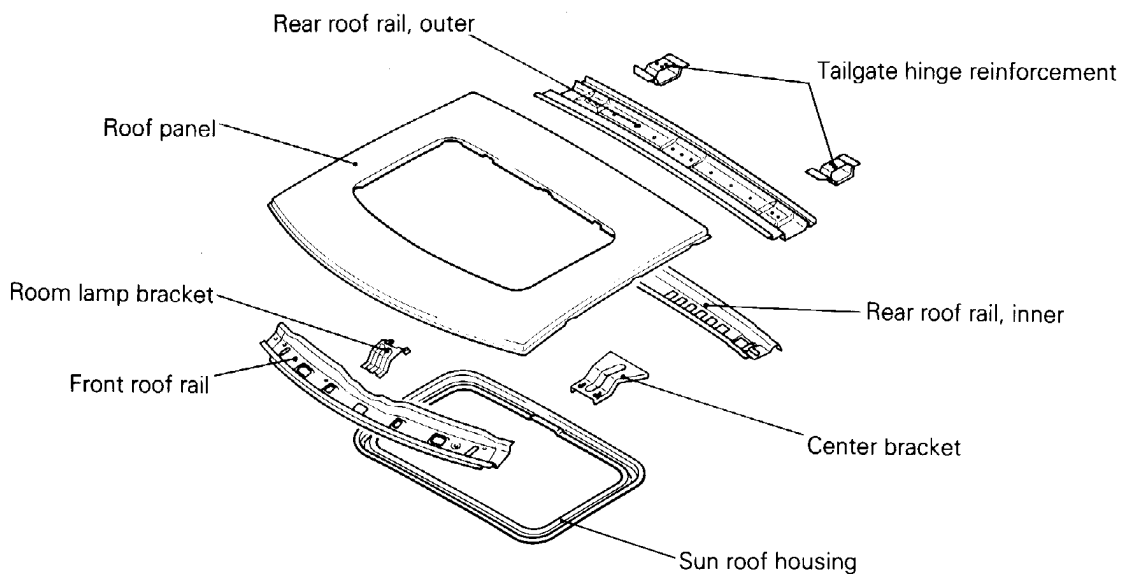

<4WD>

		mm (in.)																			
No.	①	②*	③	④	⑤*	⑥	⑦	⑧	⑨*	⑩	⑪	⑫*	⑬	⑭*	⑮	⑯*	⑰	⑱*	⑲	⑳*	㉑
Length	1,000 (39.37)	1,139 (44.84)	1,170 (46.06)	980 (38.53)	1,340 (52.74)	1,106 (43.55)	1,075 (42.34)	960 (37.80)	1,157 (45.54)	1,649 (64.92)	800 (31.50)										
No.	⑫*	⑬	⑭*	⑮	⑯*	⑰*	⑱*	⑲*	⑳*	㉑											
Length	1,014 (39.92)	714 (28.11)	1,287 (50.66)	1,020 (40.16)	1,090 (42.90)	1,506 (59.29)	780 (30.71)	1,021 (40.19)	972 (38.27)	960 (37.80)											

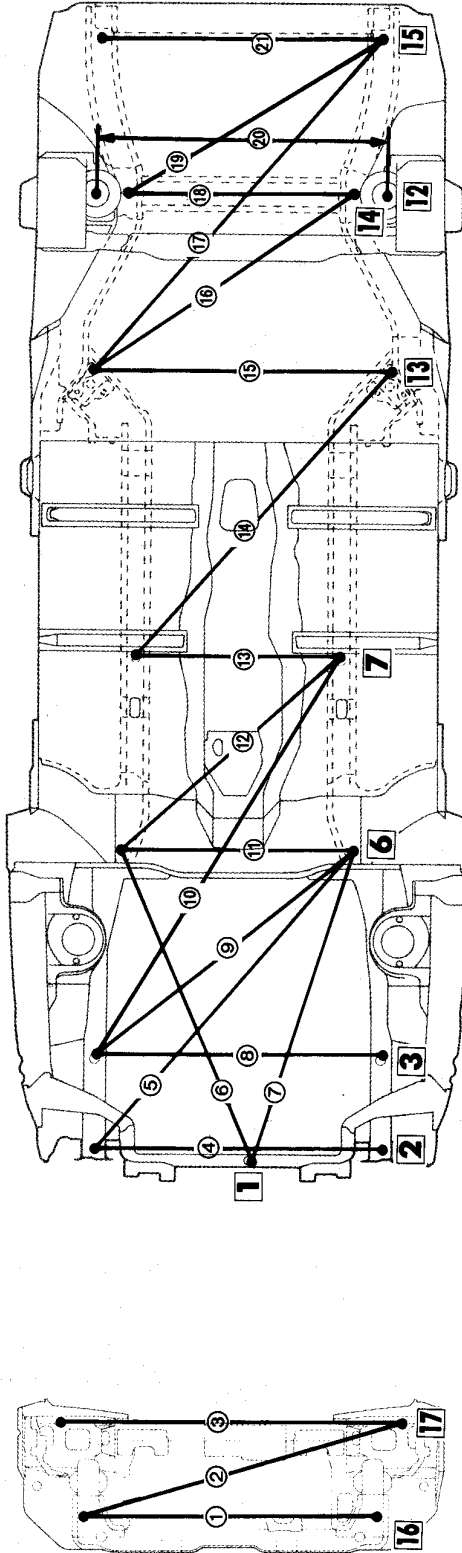

32A0116

32A0144





CLICK HERE TO **DOWNLOAD** THE COMPLETE MANUAL

- Thank you very much for reading the preview of the manual.
- You can download the complete manual from: [www.heydownloads.com](http://www.heydownloads.com) by clicking the link below



- Please note: If there is no response to CLICKING the link, please download this PDF first and then click on it.

CLICK HERE TO **DOWNLOAD** THE COMPLETE MANUAL



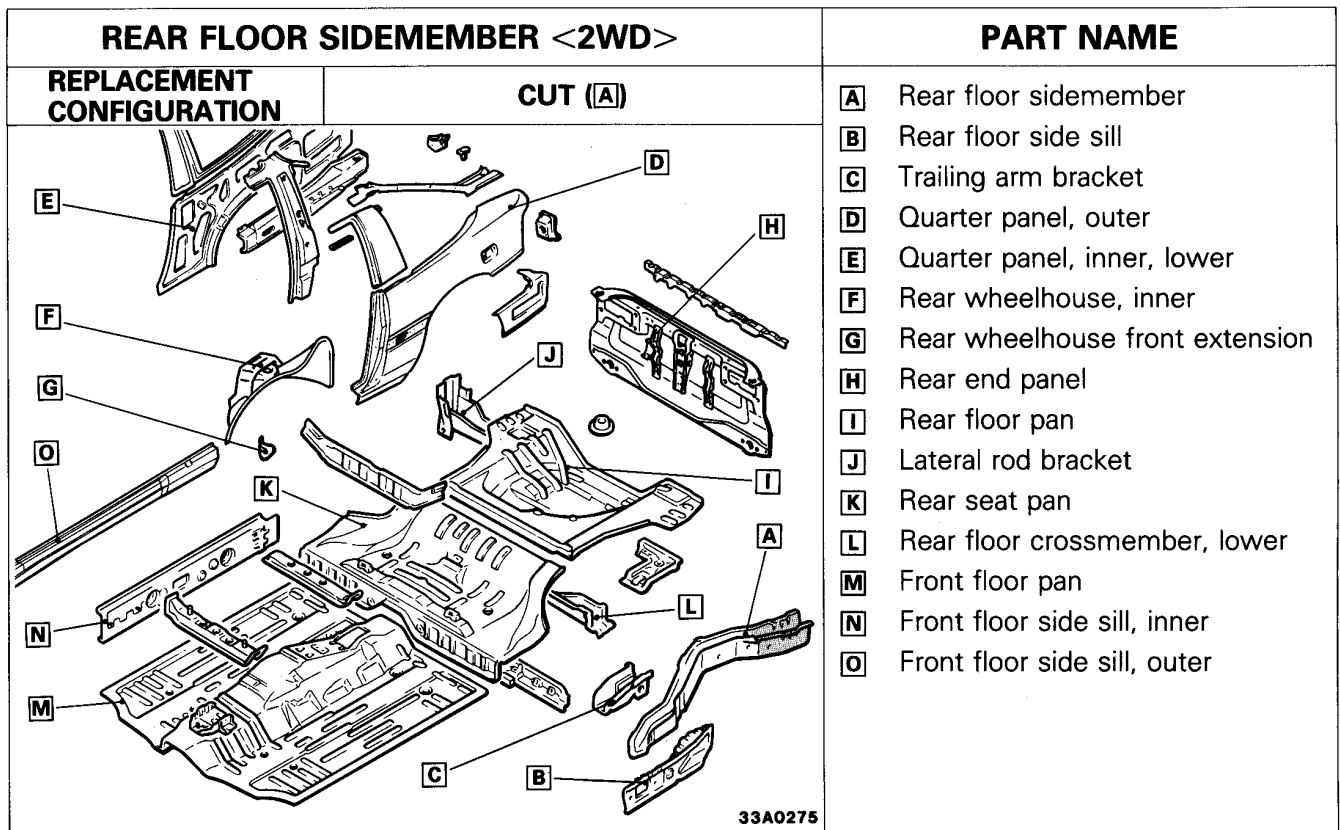

No.	Welded parts	F	R
①	A + K	14	■ 14
②	A + L	7	■ 7
③	A + K + L ★	1	■ 1
④	A + L ★	1	■ 1
⑤	A + I L.H.	17	■ 17
⑥	A + I R.H.	16	■ 16
⑦	A + I + L ★	1	■ 1
⑧	A + B	7	■ 7
⑨	A + B	2	■ 2
⑩	A + B + C ★	4	■ 4
⑪	A + C ★	7	■ 7
⑫	A + C ★	2	■ 2
⑬	B + C ★	1	■ 1
⑭	B + C ★	5	■ 5
⑮	A + H	3	■ 3
⑯	A + L ★	2	■ 2
⑰	A + J R.H. ★	2	■ 2
⑱	A + J R.H. ★	4	■ 4
⑲	A + J R.H. ★	2	■ 2
⑳	A + B	3	■ 3
㉑	A + B	1	■ 1

No.	Welded parts	F	R
㉒	B + F + G	1	■ 1
㉓	B + G	5	■ 5
㉔	B + D	10	■ 10
㉕	B + D + M	4	■ 4
㉖	B + M	1	■ 1
㉗	B + M + O	1	■ 1
㉘	B + M + N	1	■ 1
㉙	A + L	1	■ 1
㉚	A + F L.H.	14	■ 14
㉛	A + I L.H.	8	■ 8
㉜	A + I + K	1	■ 1
㉝	A + K	5	■ 5
㉞	A + B + K	1	■ 1
㉟	B + F + K	3	■ 3
㊱	A + F R.H.	12	■ 12
㊲	A + I R.H.	5	■ 5
㊳	B + N + O	2	■ 2
㊴	B + N	6	■ 6
㊵	B + D + O	1	■ 1
㊶	B + E + O	5	■ 5
㊷	B + E	3	■ 3







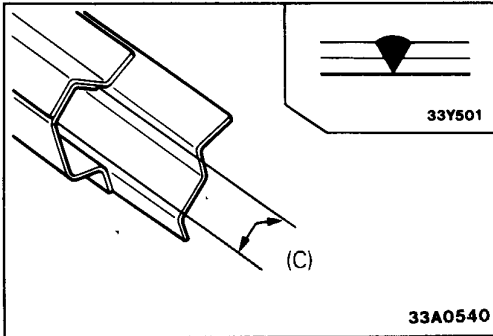

- (2) When butt-welding the part indicated by (C) in the illustration, cut the overlap part of the panel in a V shape so that bolt panels can be welded together, assuring better penetration during welding.

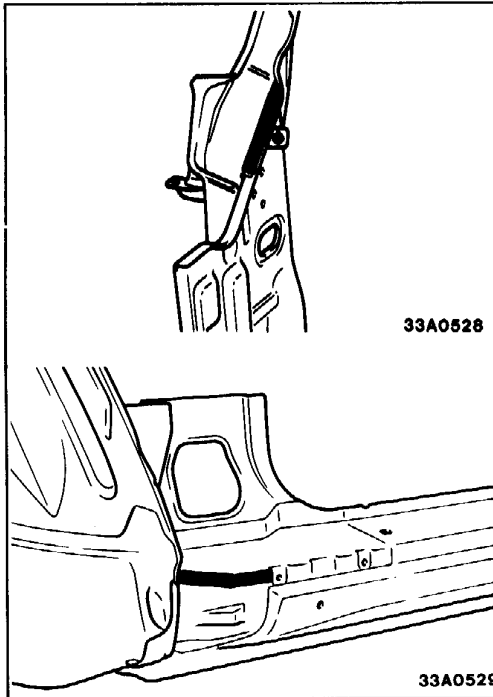

- (3) Apply a coating of silicon rubber sealer where shown in the illustration.

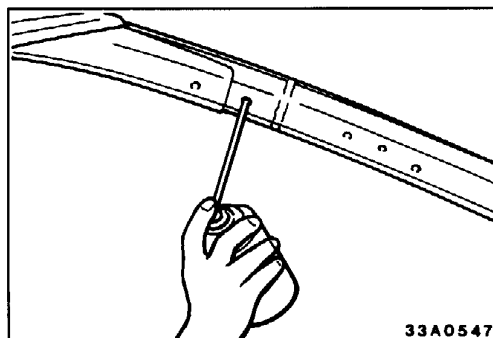

- (4) Apply a liberal amount of corrosion-prevention agent (using the front pillar trim installation hole) to the butt-weld locations.

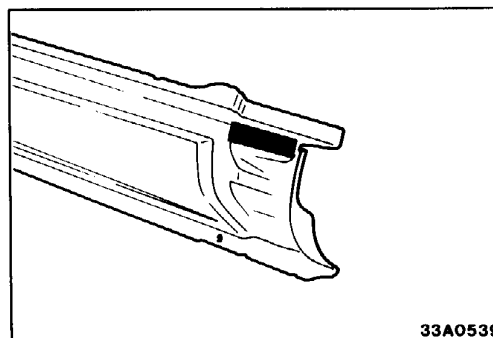

## SIDE SILL

### NOTES WITH REGARD TO REPAIR WORK

#### INSTALLATION

- (1) Apply a coating of silicon rubber sealer where shown in the illustration.

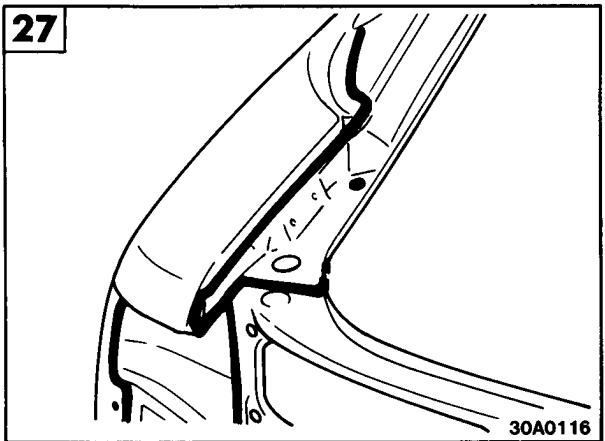
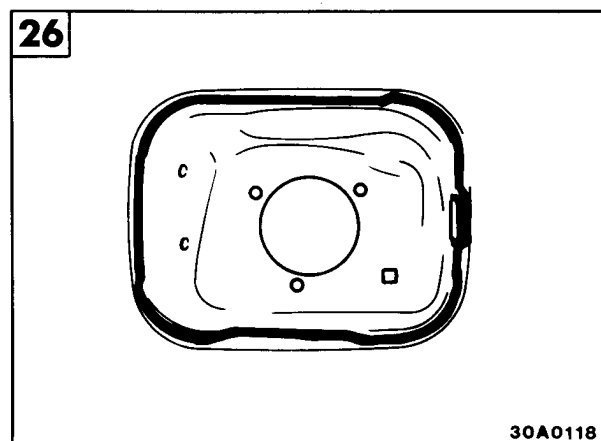
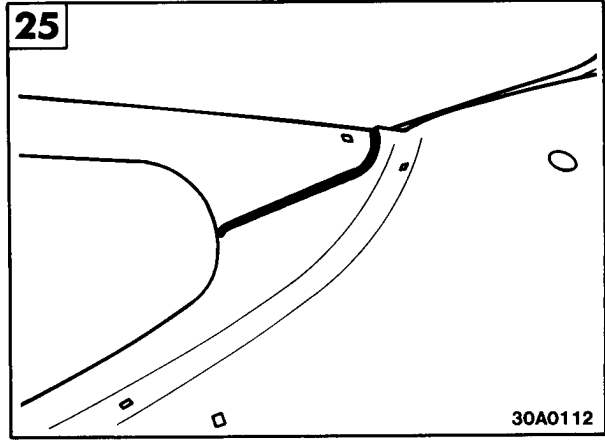
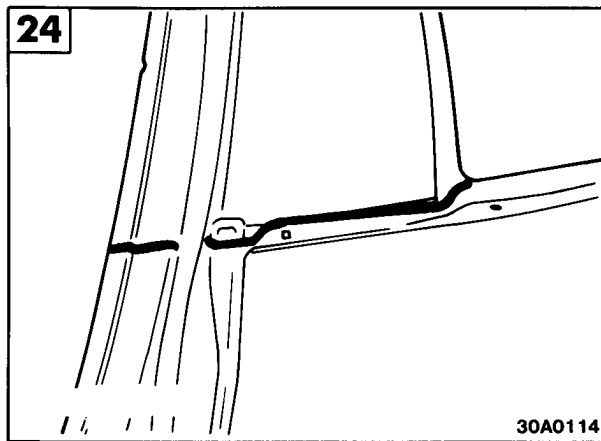
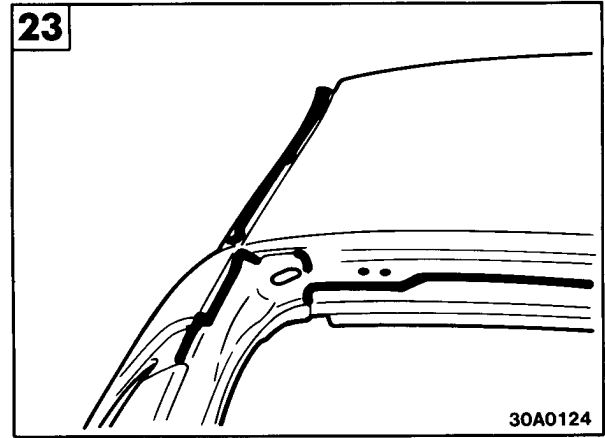
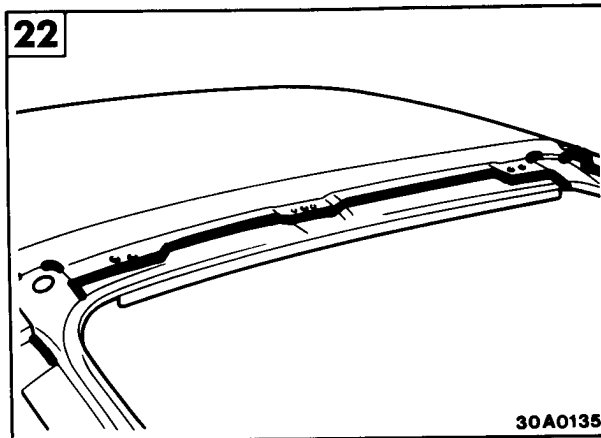
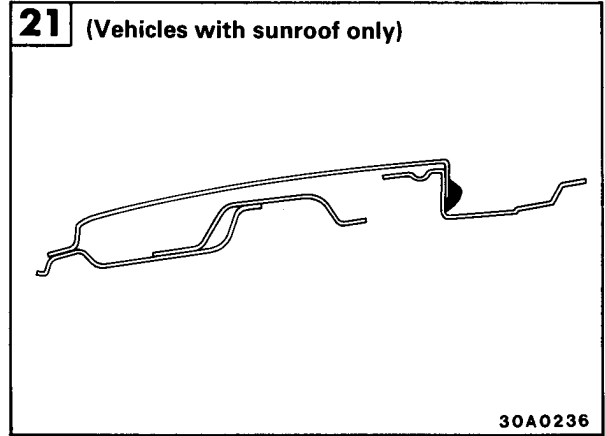
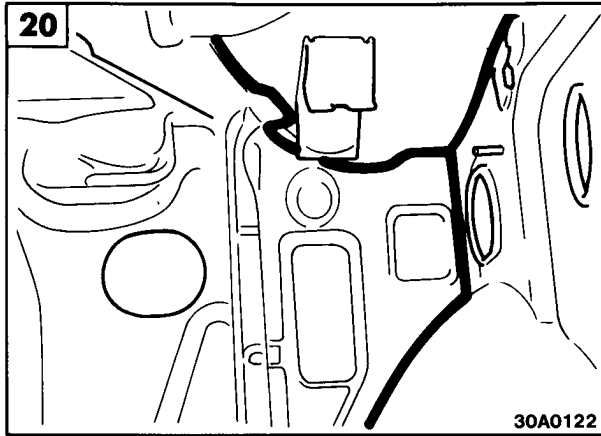

LOCATION OF SYNTHETIC-RESIN PARTS

The location and material of each of the principal synthetic-resin parts are shown below:

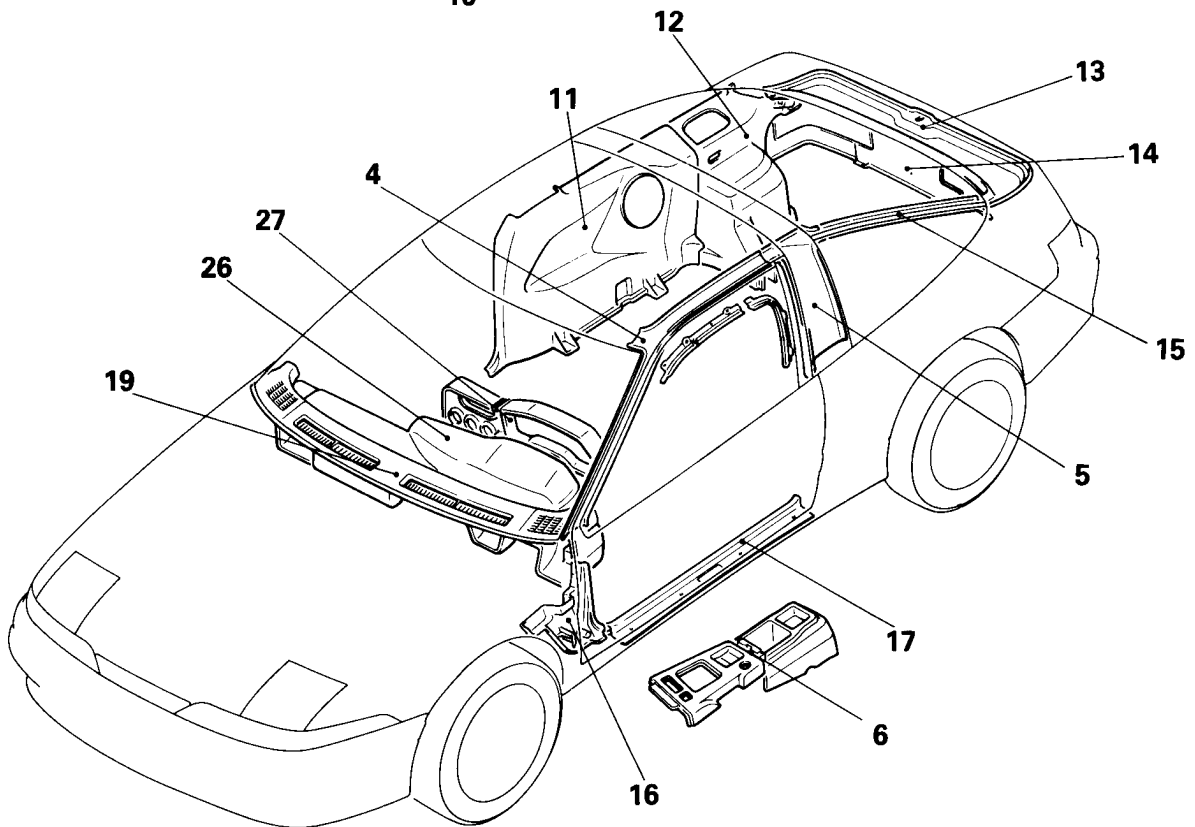
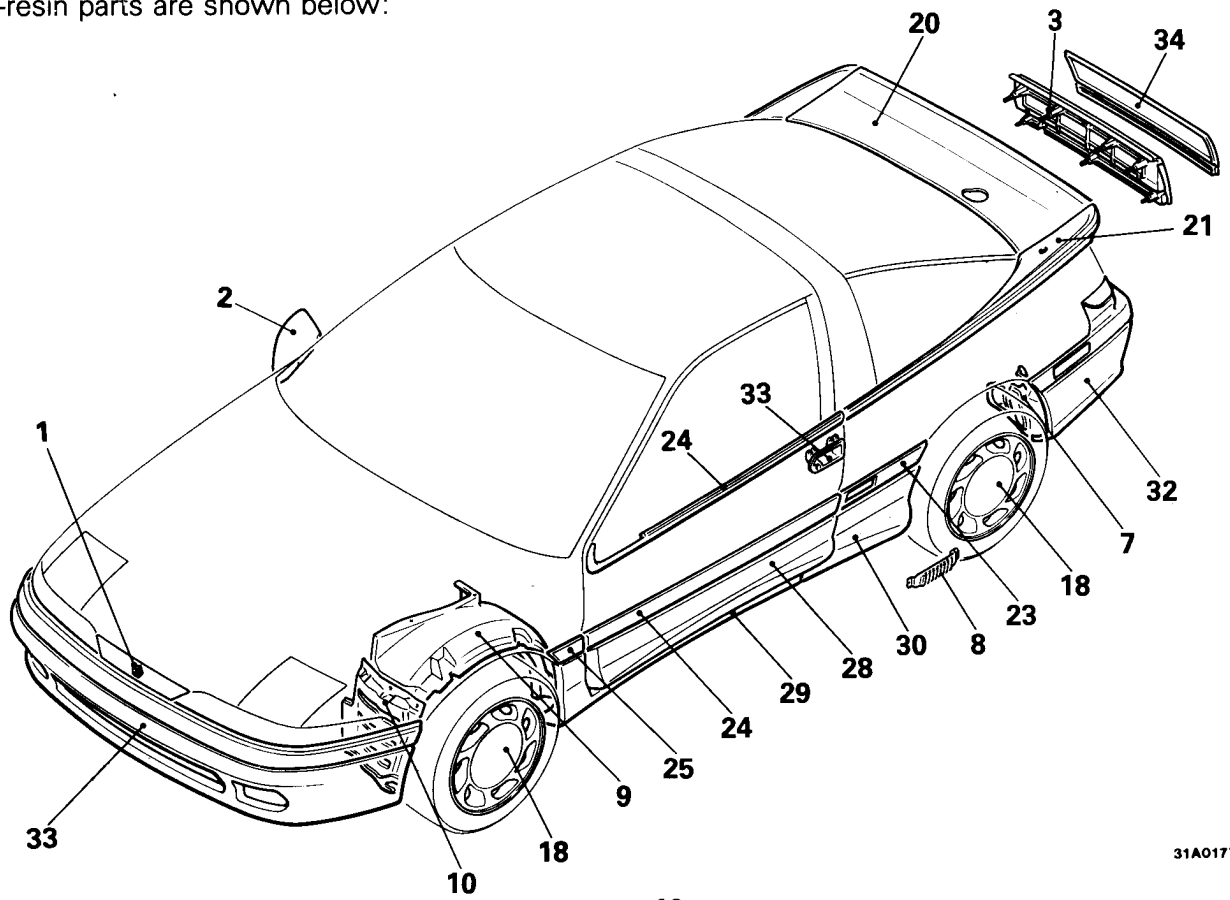

31A0177

31A0180

CLICK HERE TO **DOWNLOAD** THE COMPLETE MANUAL

- Thank you very much for reading the preview of the manual.
- You can download the complete manual from: [www.heydownloads.com](http://www.heydownloads.com) by clicking the link below



- Please note: If there is no response to CLICKING the link, please download this PDF first and then click on it.

CLICK HERE TO **DOWNLOAD** THE COMPLETE MANUAL