GROUP 0**GENERAL****CONTENTS**

VEHICLE IDENTIFICATION	0-2	SUPPLEMENTAL RESTRAINT SYSTEM (SRS)	
MAJOR SPECIFICATIONS	0-2	0-3

CLICK HERE TO **DOWNLOAD** THE COMPLETE MANUAL

- Thank you very much for reading the preview of the manual.
- You can download the complete manual from: www.heydownloads.com by clicking the link below



- Please note: If there is no response to CLICKING the link, please download this PDF first and then click on it.

CLICK HERE TO **DOWNLOAD** THE COMPLETE MANUAL

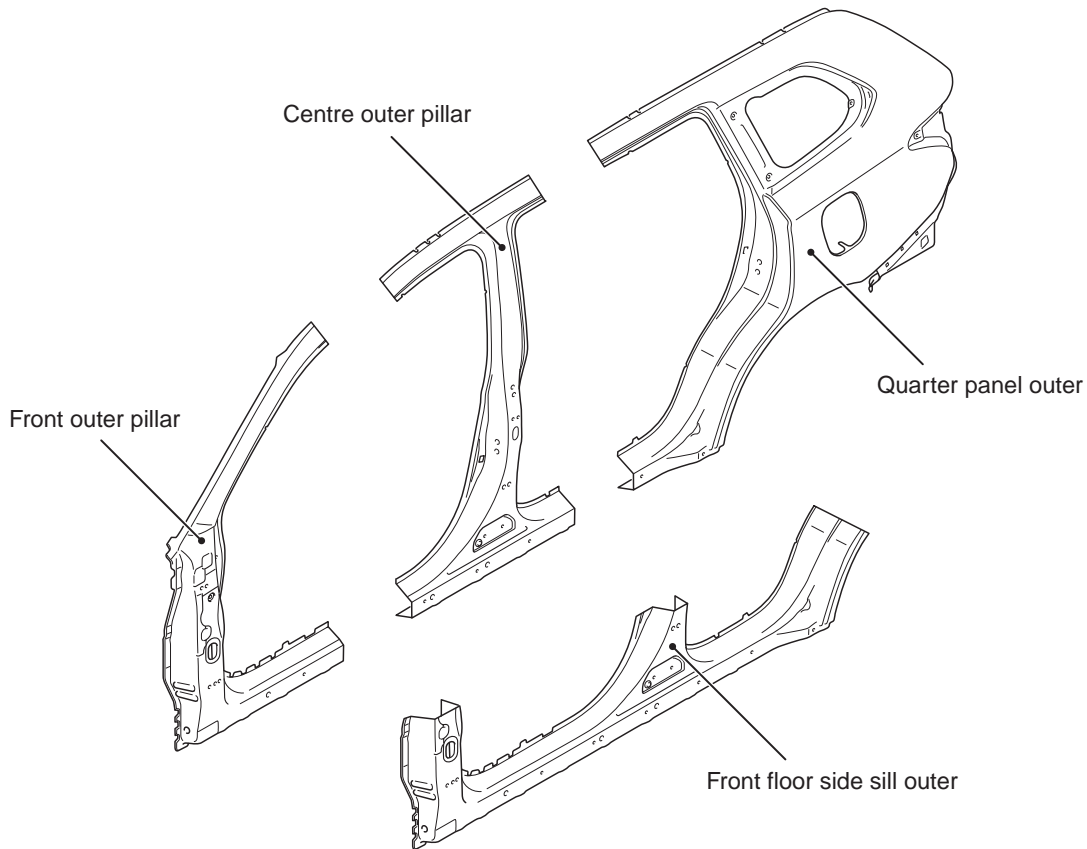

ABC00085AB

BODY CONSTRUCTION CHARACTERISTICS

FRONT BODY

M4010010001664

HEADLAMP SUPPORT

- The crush box structure, which has an octagonal cross-section at the front end of the front side-member, has been adopted. This structure can effectively absorb energy upon frontal impact and reduces the vehicle repair cost caused by a light collision.

- The bolt-on headlamp support panel upper is used to improve maintainability.

SIDE STRUCTURE REINFORCEMENT

The ring structure of the side structure reinforcement has been adopted to improve the side collision characteristics and the rigidity of the whole vehicle.



ABB00770AB

REAR BODY

M4010012001002

REAR END CROSSMEMBER

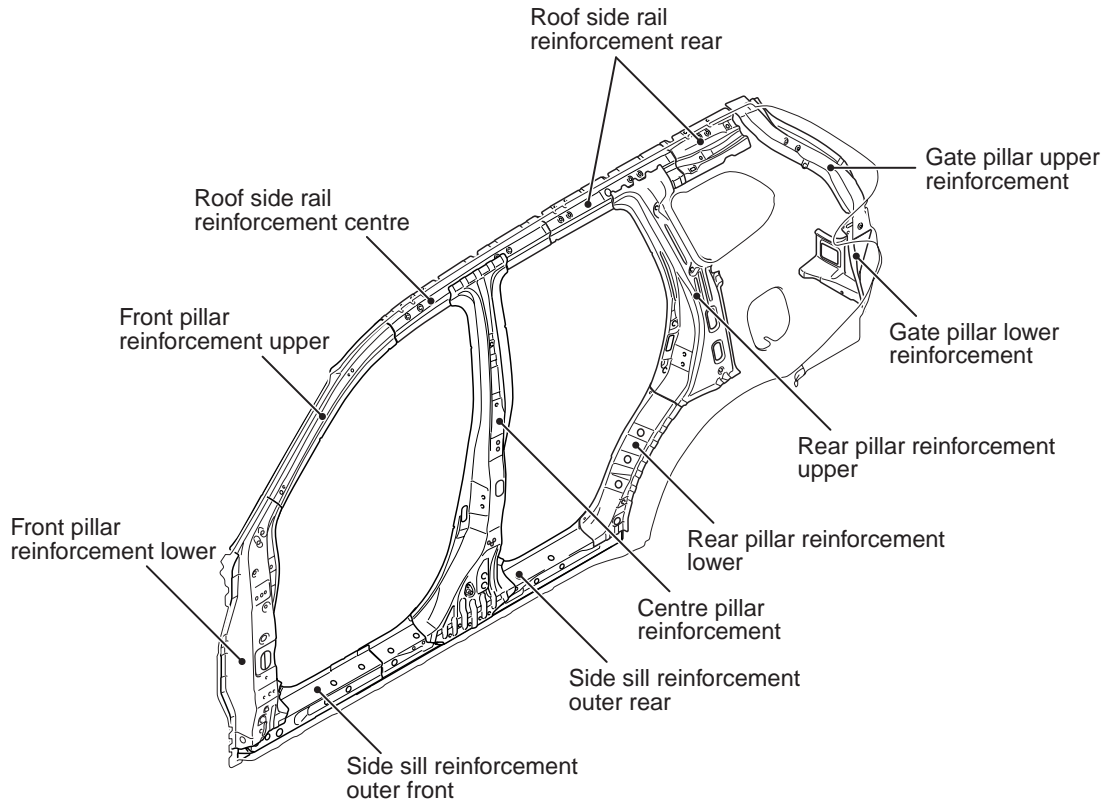
The 590-MPa class high tensile strength steel panels have been adopted for the rear end inner crossmember side to improve the frontal collision characteristics.

NOTE:

- The main contents of a stiffener are epoxy resin. It comes in a sheet form and contains a mixture of glass fibre and filler, and cures (stiffens) when heated.
- No spare part of the stiffener for repair is available in the field. If the stiffener is damaged, replace it together with the panel.



ABB00856AB



ABB00857AB

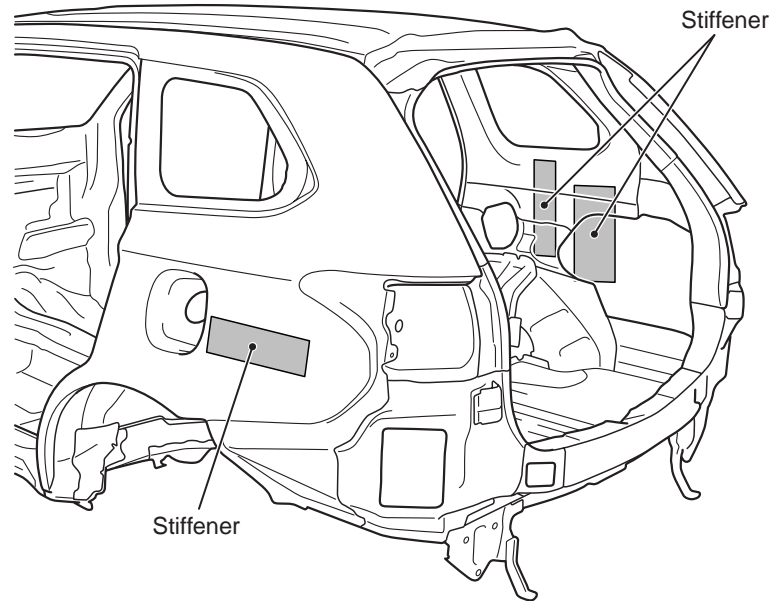

No.	Standard measurement point	Hole shape	Size mm
64	Alignment projection on the rear seat under floor (Body centre point)	–	–
65	Centre of rear shock absorber assembly mounting hole	Round	14
66	Centre of rear end trim mounting hole	Round	8.5

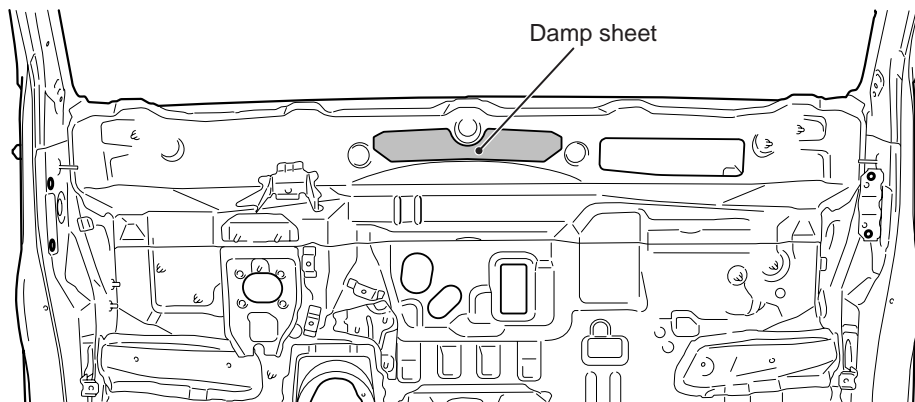
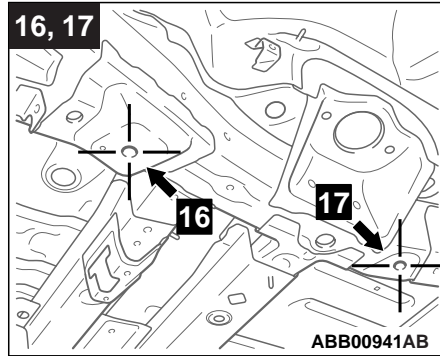
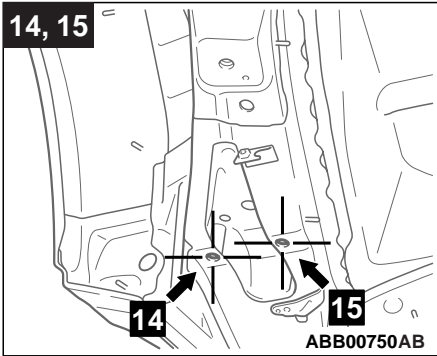
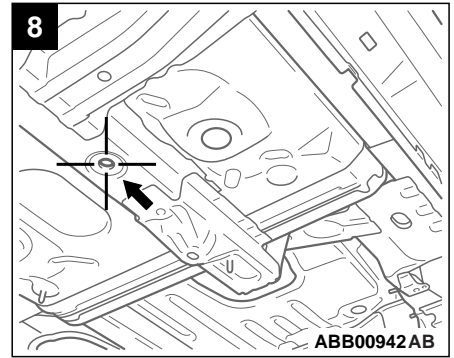
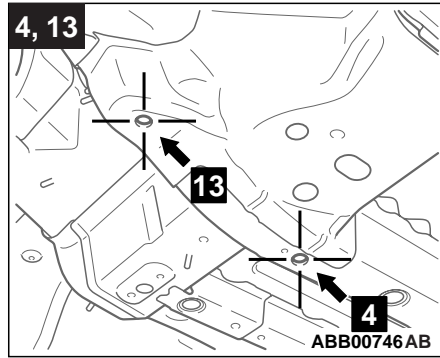
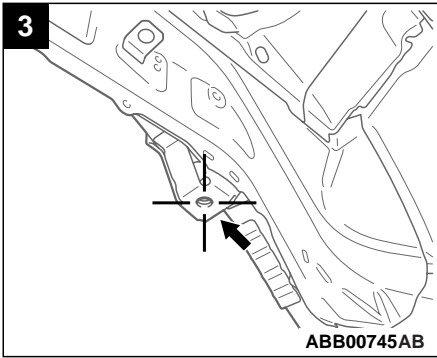
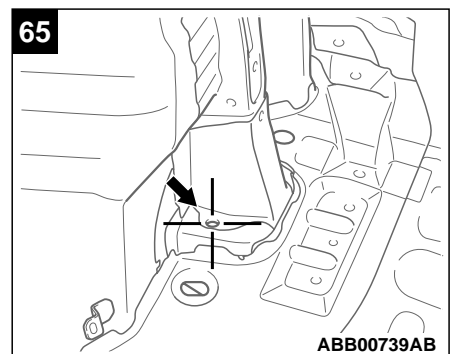
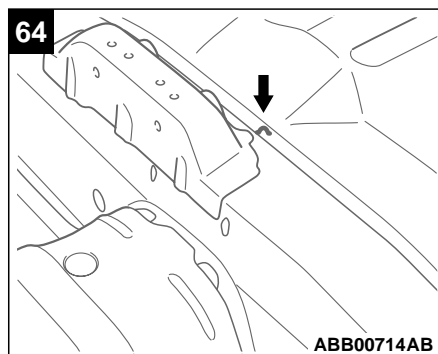
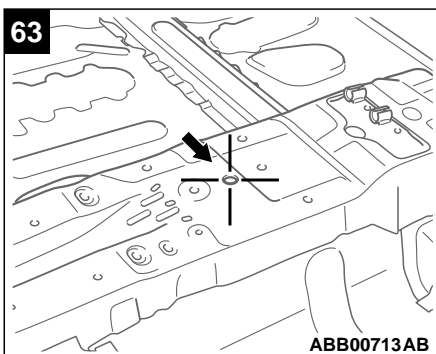
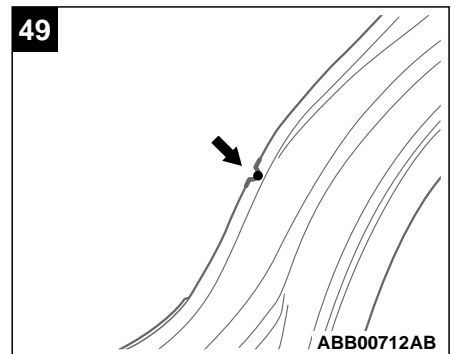
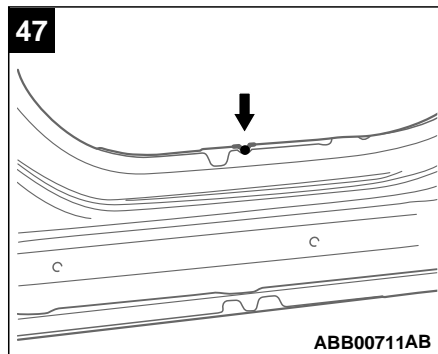
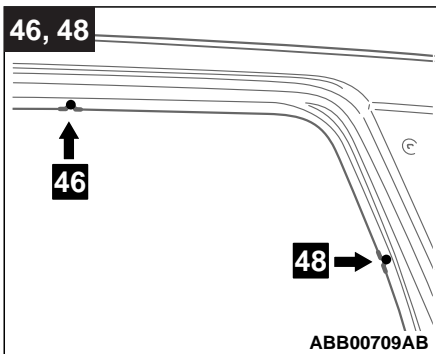
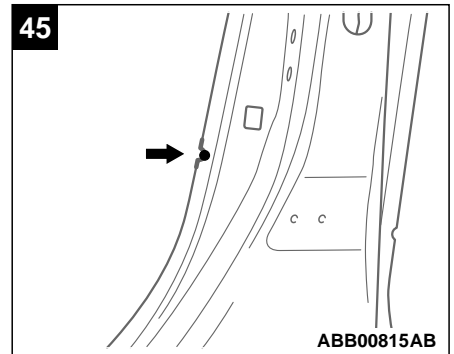
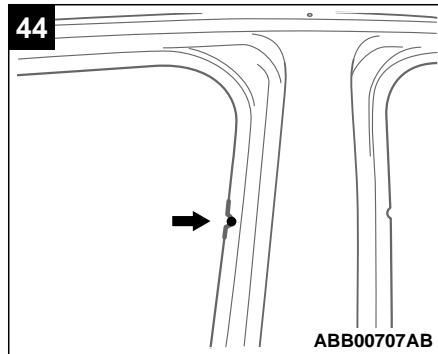
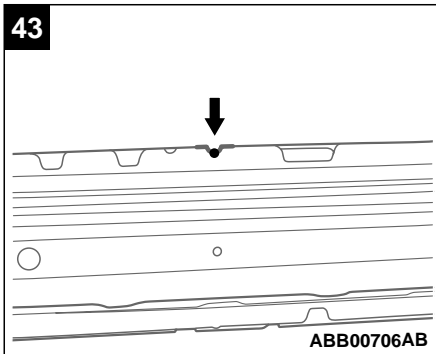
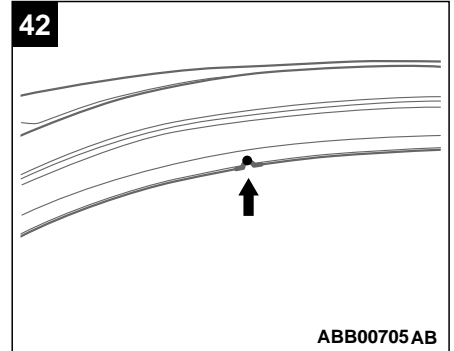
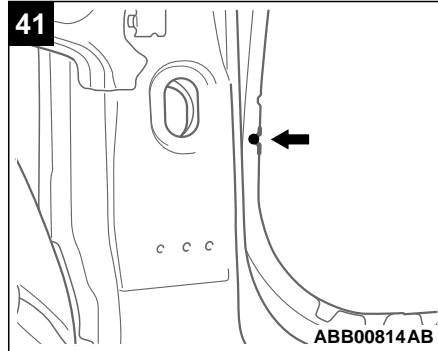
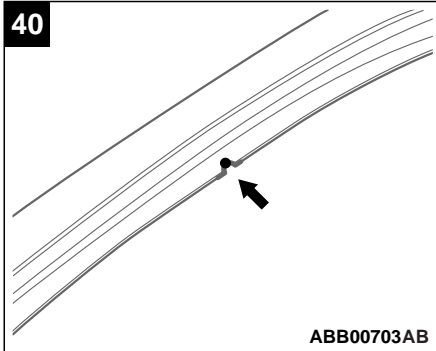

FRONT PILLAR

M4030005002113

CAUTION

When repairing the area using sound dampening foam material do not use firing tools since the sound dampening foam material may burn.

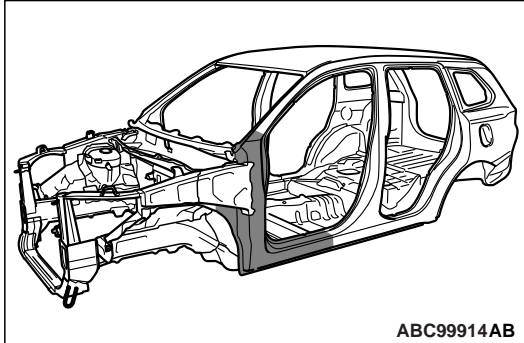

Symbol	Operation description
● ● ● ●	Spot welding
■ ■ ▲ ▲	MIG plug welding (■: indicates two panels to be welded ▲: indicates three panels to be welded)
++++	MIG spot welding
#####	MIG arc welding (continuous)
○○○○○○	Braze welding
	Anti-corrosion agent application locations (Use access holes to apply liberally to butt-welded joints.)

REPAIR WELDS



ABB00889AB

REPAIR WELDS



A

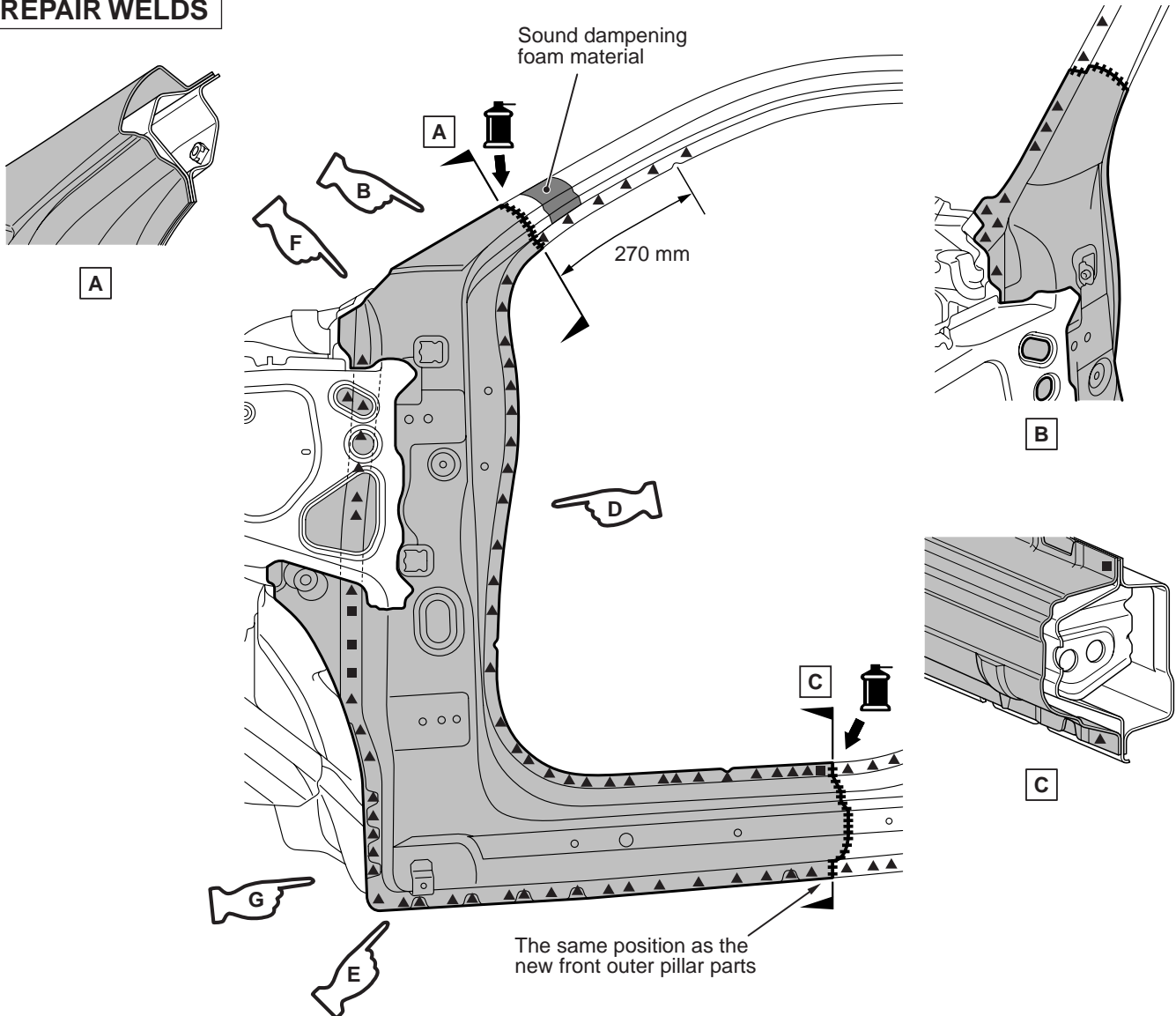
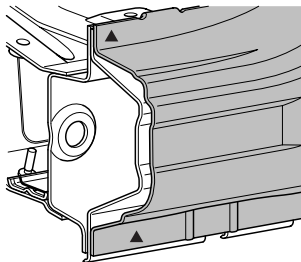
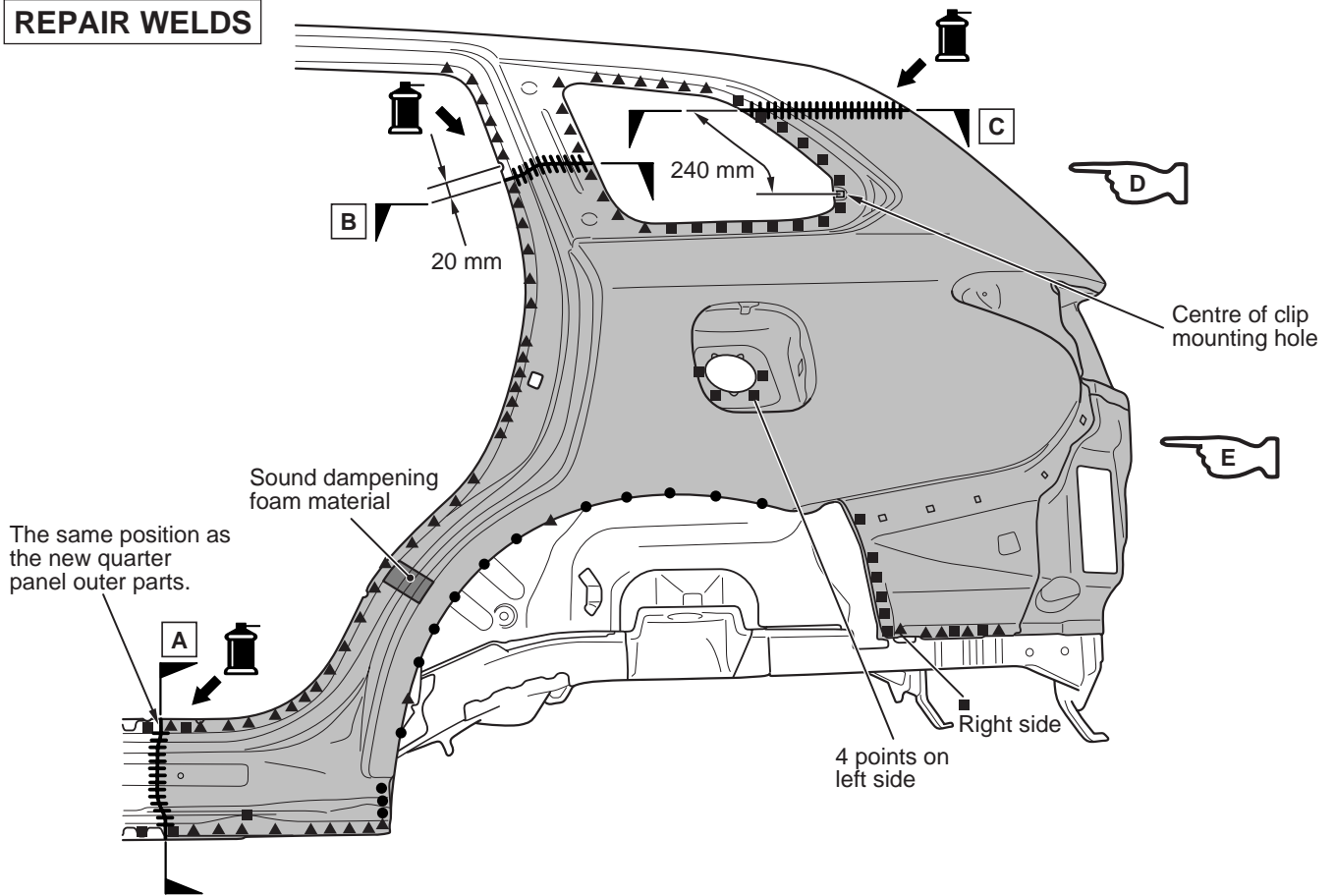
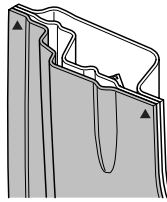

B

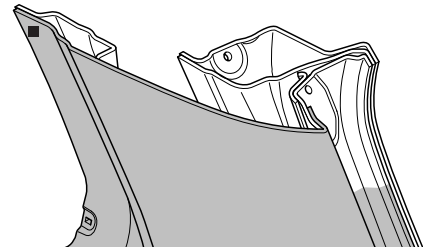

C

Sound dampening foam material: 3M ATD
 Part No.08463

- Wait 2 hours after filling the sound dampening foam material to remove the bolt and aluminium tape, then melt the sound dampening foam material with a soldering gun so a clip, etc. can thoroughly be inserted in the hole filled with sound dampening foam material.

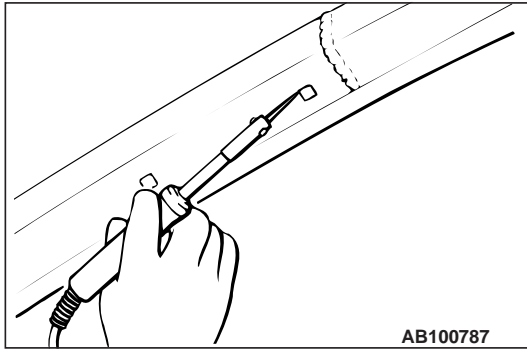



QUARTER INNER LOWER

M4030001100338

CAUTION

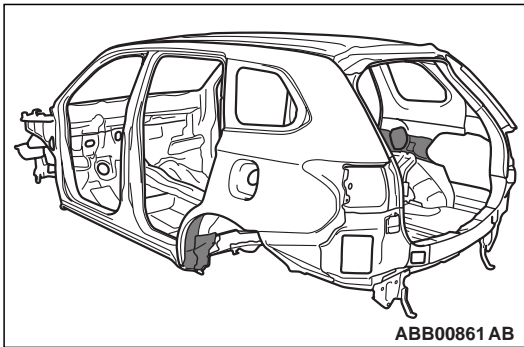
When repairing the area using sound dampening foam material do not use firing tools since the sound dampening foam material may burn.



Symbol	Operation description
● ● ● ●	Spot welding
■ ■ ▲ ▲	MIG plug welding (■: indicates two panels to be welded ▲: indicates three panels to be welded)
++++	MIG spot welding
#####	MIG arc welding (continuous)
oooooo	Braze welding
	Anti-corrosion agent application locations (Use access holes to apply liberally to butt-welded joints.)

SIDE BODY

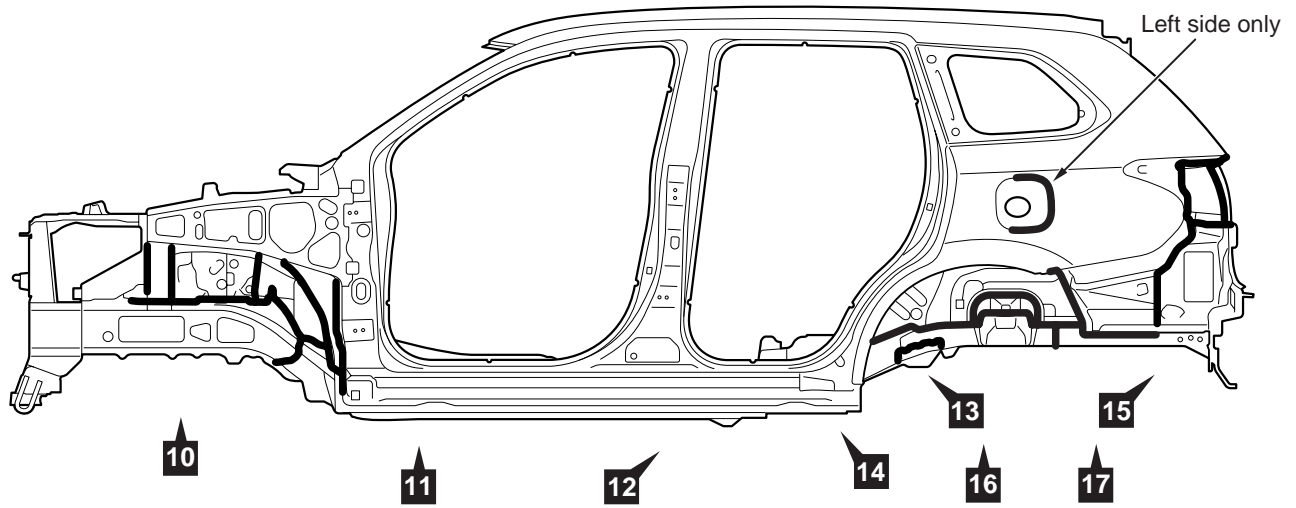

ABC00078AB

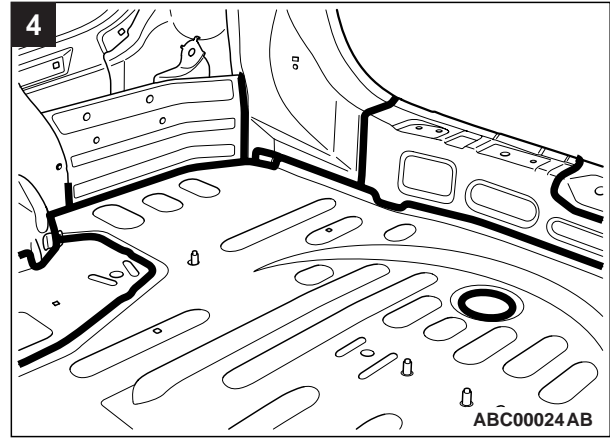
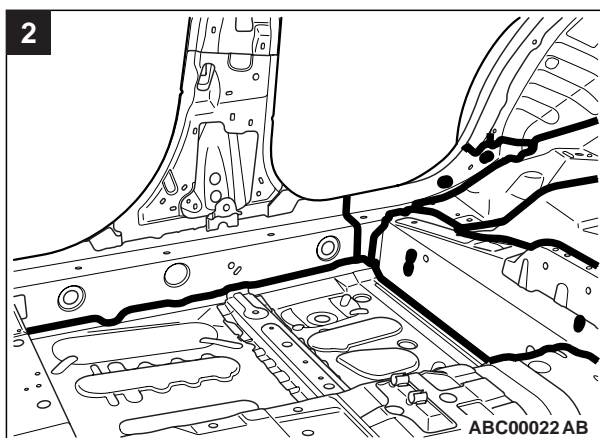
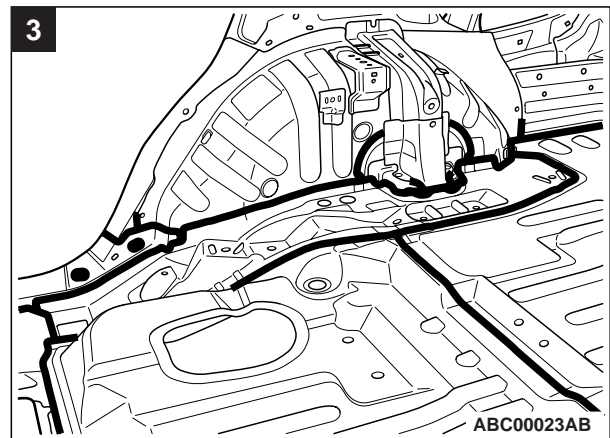
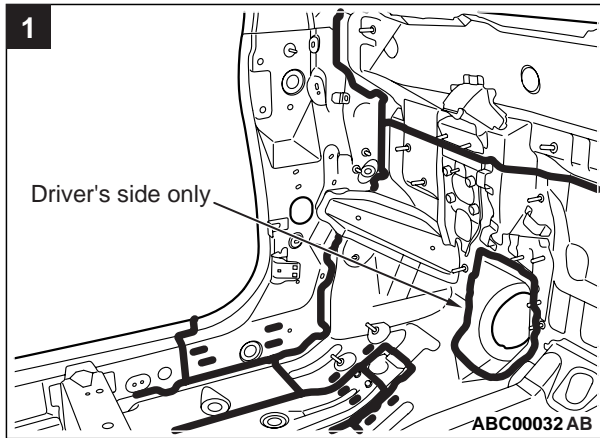

CLICK HERE TO **DOWNLOAD** THE COMPLETE MANUAL

- Thank you very much for reading the preview of the manual.
- You can download the complete manual from: www.heydownloads.com by clicking the link below



- Please note: If there is no response to CLICKING the link, please download this PDF first and then click on it.

CLICK HERE TO **DOWNLOAD** THE COMPLETE MANUAL